

## INFORMATION TO USERS

This manuscript has been reproduced from the microfilm master. UMI films the text directly from the original or copy submitted. Thus, some thesis and dissertation copies are in typewriter face, while others may be from any type of computer printer.

**The quality of this reproduction is dependent upon the quality of the copy submitted.** Broken or indistinct print, colored or poor quality illustrations and photographs, print bleedthrough, substandard margins, and improper alignment can adversely affect reproduction.

In the unlikely event that the author did not send UMI a complete manuscript and there are missing pages, these will be noted. Also, if unauthorized copyright material had to be removed, a note will indicate the deletion.

Oversize materials (e.g., maps, drawings, charts) are reproduced by sectioning the original, beginning at the upper left-hand corner and continuing from left to right in equal sections with small overlaps.

Photographs included in the original manuscript have been reproduced xerographically in this copy. Higher quality 6" x 9" black and white photographic prints are available for any photographs or illustrations appearing in this copy for an additional charge. Contact UMI directly to order.

Bell & Howell Information and Learning  
300 North Zeeb Road, Ann Arbor, MI 48106-1346 USA  
800-521-0600

UMI<sup>®</sup>

## **NOTE TO USERS**

**Page(s) not included in the original manuscript and are unavailable from the author or university. The manuscript was microfilmed as received.**

**61**

**This reproduction is the best copy available.**

**UMI<sup>®</sup>**

DISSERTATION

**GIS - BASED IRRIGATION SCHEDULING  
AND ON FARM WATER ALLOCATION**

Submitted by

**Silvana Della Manna**

Department of Chemical and Bioresource Engineering

In partial fulfillment of the requirements

For the degree of Doctor of Philosophy

Colorado State University

Fort Collins, Colorado

Fall 2000

UMI Number: 3002070

UMI<sup>®</sup>

---

UMI Microform 3002070

Copyright 2001 by Bell & Howell Information and Learning Company.

All rights reserved. This microform edition is protected against  
unauthorized copying under Title 17, United States Code.

---

Bell & Howell Information and Learning Company  
300 North Zeeb Road  
P.O. Box 1346  
Ann Arbor, MI 48106-1346

COLORADO STATE UNIVERSITY

November 6, 2000

WE HEREBY RECOMMEND THAT THE DISSERTATION PREPARED UNDER OUR SUPERVISION BY SILVANA DELLA MANNA ENTITLED "GIS-BASED IRRIGATION SCHEDULING AND ON FARM WATER ALLOCATION" BE ACCEPTED AS FULFILLING IN PART REQUIREMENTS FOR THE DEGREE OF DOCTOR OF PHILOSOPHY.

Committee on Graduate Work

*Paul Ayers*  
\_\_\_\_\_  
*Shirley M. ...*  
\_\_\_\_\_  
*...*  
\_\_\_\_\_

*Paul F. Heermann*  
\_\_\_\_\_  
Adviser  
*V. J. Murphy*  
\_\_\_\_\_  
Department Head

**ABSTRACT OF DISSERTATION**  
**GIS-BASED IRRIGATION SCHEDULING**  
**AND ON FARM WATER ALLOCATION**

A GIS-based irrigation scheduling and on farm water allocation program was developed for irrigated crops to assist farmers in maintaining or increasing yields while minimizing water losses and crop stress to water supply shortage. The use of GIS offers a unique approach for agricultural managers to analyze spatial and temporal variability while investigating crop management strategies for water allocation for crops. The system is composed of three modules. The main components of these modules are, an irrigation scheduler, a field water priority setting and an on farm water allocation model. The irrigation scheduler has four sub-modules; climatic data, crop growing period, crop information for a specific field, crop coefficient, and evaporation from a wet soil.

The irrigation scheduler uses a traditional soil-water mass balance approach and the concept of management allowable depletion level to trigger the irrigation water needed for a specific crop. The program operates in a real-time mode, using daily crop evapotranspiration and forecasts irrigation water requirements, based on climatic averages. Management allowable depletion levels can be preset for each crop growth stage.

Reference evapotranspiration is manually entered into the system. It is calculated by another program using the Penman-Monteith method or can use any other available method.

When water is limited to some crops in the field during a given day, a crop-water priority setting considers the kind of crop grown, rooting depth, stage of growth, crop sensitivity to water stress, crop yield, soil storage capacity and management allowable depletion. Water is allocated to the fields based on this priority setting, water availability and irrigation system constraints. The GIS program will automatically transfer the fields that were left without irrigation to the next day.

The value of this research lies on the integrated analysis of climatic and crop data for the determination and allocation of a limited water supply for crops, that varies in space and time. Also, water demand can vary within a field or from field to field. It provides the ability to process and store a large volume of data in the GIS database layers creating water allocation scenarios and exploring different alternatives in a very efficient manner. The methodology was applied to an agronomic farm of 200 acres located in Larimer County in Colorado.

**Silvana Della Manna  
Department of Chemical and Bioresources Engineering  
Colorado State University  
Fort Collins, CO 80523  
Fall 2000**

## **ACKNOWLEDGMENTS**

I would like to express appreciation for Dr. Dale F. Heermann for his intelligent guidance and advice during my graduate career and for providing me with an excellent working environment.

I would like to thank Dr. Merlyn Paulson for supporting in so many different ways during my program and for schooling me in the art of GIS techniques and its intricacies.

I would like to thank Dr. Paul Ayers, Dr. Dwayne Westfall and Dr. Ramchand Oad for their assistance, constructive criticism and professionalism.

The author wishes to convey a special thanks to the parents and husband for contributing with interest and knowledge as well as for the encouragement and support to pursue a Ph.D.

## TABLE OF CONTENTS

<b>1. INTRODUCTION .....</b>	<b>1</b>
1.1 Research Site.....	1
1.2 Crop–Water Management.....	1
1.3 Why Use GIS .....	3
1.4 Objectives.....	5
1.5 Literature Review .....	6
1..5.1 Irrigation Scheduling .....	6
1.5.2 Water Allocation .....	7
1.5.3 GIS Modeling for Precision Farming.....	9
1.5.4 Irrigation Scheduling and On-Farm Water Allocation Models .....	13
1.6 An Overview of the Project .....	17
1.6.1 System Design.....	17
1.6.2 Water Allocation Priority Decision Algorithm.....	19
1.7 Types of Maps Used in the Model.....	23
1.8 Procedures and Work Plan.....	24
1.9 Technology Transfer.....	29

<b>2. IRRIGATION SCHEDULER STRUCTURE .....</b>	<b>30</b>
2.1 An overview of the Irrigation Scheduler Model Design .....	30
2.1.1 Model Objectives.....	30
2.1.2 Forecasting Evapotranspiration Amount .....	32
2.1.3 Model Design Philosophy .....	33
2.1.4 Model Assumptions and Considerations.....	37
2.2 Calculations.....	39
2.2.1 Soil Water Mass Balance .....	39
2.2.2 Description of Scheduling Algorithms.....	40
2.3 Program Data Requirements .....	51
2.3.1. Location Information.....	51
2.3.2. Field Information.....	52
2.3.3 Geographic Databases .....	57
<b>3. WATER ALLOCATION .....</b>	<b>60</b>
3.1 An Overview of the On-Farm Water Allocation Model Design.....	60
3.1.1 Model Objective.....	60
3.1.2 Model Scope .....	61
3.1.3 Model design and philosophy.....	61
3.2 Variables Included in the Model.....	63
3.2.1 Crop Type and Grow Stage Affect Water Allocation Priority.....	63
3.2.2 Soil Moisture Removal and Depth of Crop Root Zones .....	65
3.2.3 Crop Type and Sensitivity to Water Stress.....	66

3.3 Multi Parameter Approach Criteria .....	68
3.4 Allocating the Available Water to Each of the Irrigated Crops .....	71
3.5 Description of the Irrigation System.....	72
3.5. 1 Water Sources at the ARDEC-Farm .....	73
3.6 Hydraulics of Flow .....	78
3.7 System Capabilities.....	80
3.8 Integration with Farming Operations.....	81
3.9 Results of the Irrigation Scheduling and Water Allocation.....	82
3.9.1 Verifying the Results of Daily Depletion using GIS and the SCHED Model .....	83
3.9.2 Comparing the GIS On-Farm Water Allocation Model with the SCHED Model.....	83
3.9.3 Explanation of the GIS-Model Results -Water Conflict Resolution .....	92
3.10 Model Uncertainty .....	99
<b>4. SUMMARY AND CONCLUSIONS.....</b>	<b>113</b>
4.1 An Overview of System Design .....	113
4.2 Model Evaluation and General Conclusions .....	114
4.3 Perspective for Farm Management .....	116
<b>REFERENCES .....</b>	<b>118</b>

## LIST OF TABLES

Table 1.1 Ky -- Yield response factor for crops at different stages of grow.....	22
Table 2.1 Average crop development days in Colorado .....	41
Table 2.2 Constants for the Crop Coefficient Equation $K_t = AR^3 + BR^2 + CR + D$ .....	43
Table 2.3 Rooting depth for selected irrigated crops in Colorado .....	45
Table 2.4 Soil database .....	53
Table 2.5 Irrigation application efficiencies .....	54
Table 2.6 Suggested maximum allowable depletions for different stages of grow.....	57
Table 3.1 Growth period during which crops are more sensitive to water stress.....	67
Table 3.2 Water allocation order .....	70
Table 3.3 Start and stop time for the application of water to each field - July 2.....	86
Table 3.4 Number of hours of operation of each well and ditch water - July 2 .....	87
Table 3.5 Estimated depletion calculated for a period of a month (June 14 - July 14), using SCHED and GIS programs -- field# at ARDEC is 1030.....	88
Table 3.6 Estimated Depletion Calculated for a period of a month (June 14 - July 14), Using SCHED and GIS programs -- field# at ARDEC is 200A.....	89
Table 3.7 Estimated Depletion Calculated for a period of a month (June 14 - July 14), using SCHED and GIS programs -- field# at ARDEC is 700.....	90

Table 3.8 SCHED field-data-file .....	93
Table 3.9 Sequence of screens used by the GIS model to perform calculations	
Module – 1 .....	94
Table 3.10 Sequence of screens used by the GIS model to perform calculations	
Module – 2 .....	95
Table 3.11 Sequence of screens used by the GIS model to perform calculations	
Module – 3 .....	96
Table 3.12 Sequence of screens used by the GIS model to perform calculations	
Module – 6 .....	97
Table 3.13 ARDEC--Fields that need to be irrigated -- and the ones that were actually irrigated -- The date is June 18--It does not include field 900 .....	100
Table 3.14 ARDEC--Fields that need to be irrigated -- and the ones that were actually irrigated --The date is June 19--It includes field 900.....	101
Table 3.15 ARDEC--Fields that need to be irrigated -- and the ones that were actually irrigated -- The date is June 18--It includes field 900.....	102
Table 3.16 ARDEC--Fields that need to be irrigated -- and the ones that were actually irrigated --The date is June 19--It does not include field 900 anymore .....	104
Table 3.17 ARDEC--Fields that need to be irrigated -- and the ones that were actually irrigated --The date is July 3 .....	105
Table 3.18 ARDEC--Fields that need to be irrigated -- and the ones that were actually irrigated --The date is July 4 .....	108

Table 3.19 ARDEC--Fields that need to be irrigated -- and the ones that were actually irrigated on July 5 - Water was available to supply requested demand ..... 111

## LIST OF FIGURES

Figure 1.1 Farm location.....	2
Figure 1.2 Map layers for the GIS.....	25
Figure 1.3 GIS project layers and attributes .....	27
Figure 1.4 The modeling process of GIS data.....	28
Figure 2.1 Thiessen polygon construction method.....	35
Figure 2.2 Crop evapotranspiration and water demand model .....	36
Figure 2.3 Root growth model.....	45
Figure 2.4 Crop coefficient curves .....	48
Figure 3.1 Generalized curve comparing consumptive use-evaporation ratio to relative growth of crop .....	64
Figure 3.2 ARDEC - Crop system lay-out.....	74
Figure 3.3 ARDEC - Soil distribution lay-out.....	75
Figure 3.4 ARDEC - Irrigation system lay-out .....	76
Figure 3.5 ARDEC - Pipe distribution system lay-out.....	77
Figure 3.6 ARDEC - Valves and main pipes distribution system lay-out .....	79
Figure 3.7 ARDEC - Map showing water - allocation for July 1, July 2, July 3 and July 4 .....	84

Figure 3.8 ARDEC - Lay-out of Fields overlaid by the soil map .....	85
Figure 3.9 ARDEC -- Fields being irrigated--The date is June 18--It includes field 900 .....	103
Figure 3.10 ARDEC -- Fields that need to be irrigated--The date is July 3.....	106
Figure 3.11 ARDEC -- Fields actually being irrigated--water was limited--The date is July 3.....	107
Figure 3.12 ARDEC -- Fields that need to be irrigated--The date is July 4:.....	109
Figure 3.13 ARDEC -- Fields actually being irrigated--water was limited--The date is July 4.....	110
Figure 3.14 ARDEC -- Fields that need to be irrigated--The date is July 5--Water was available to supply requested demand.....	112

# **CHAPTER 1**

## **INTRODUCTION**

### **1.1 Research Site**

Colorado State University acquired an agronomic farm to perform research and to develop projects in irrigated agriculture. The research facility comprises an area of 200 acres located in Larimer County, Colorado at the intersection between I-25 frontage road and County Road 56 as shown in figure 1.1.

### **1.2 Crop-Water Management**

Agriculture research aims at minimizing environmental degradation and sustaining production. Historically, producers manage crops to maximize yield and have the tendency of over application of water as an "insurance" against loss in yield. This "insurance" philosophy was based upon the perception that the more water the better the chances for high yield. The complex interaction between crop; soil and water; make it difficult for a farmer to actually determine the minimum amount of water required to obtain maximum yield. Hence most farmers tend to over irrigate.

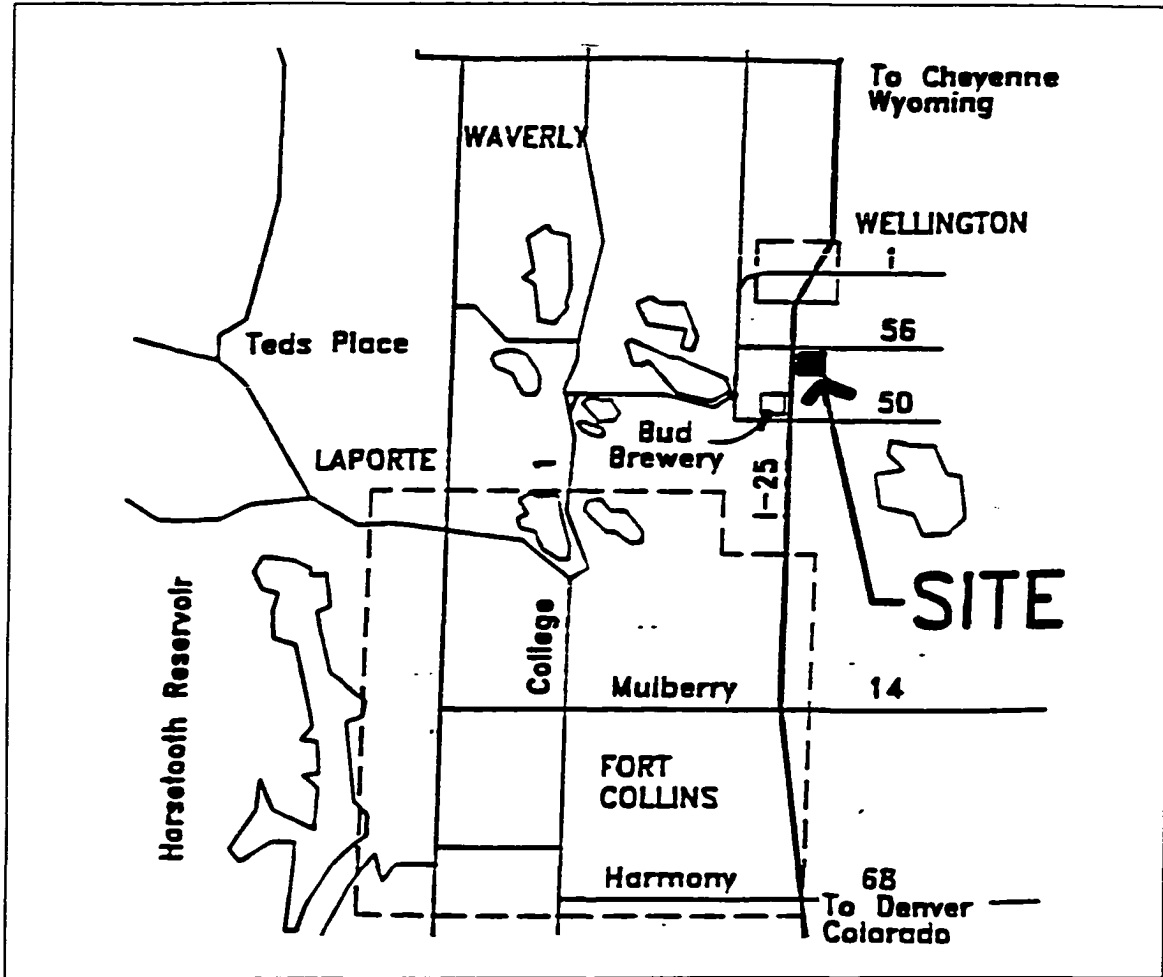

**Figure 1.1 Farm location**

Today, water conservation has become a necessity because water is and will become scarce natural resource in the near future (Beyazgul et al., 2000). According to Yevjevich (1992), the issue of water conservation may be defined in several ways, depending upon the individuals' school of thought. For environmentalists, water conservation means undertaking measures that would decrease water demand per capita, such as the use of less water per irrigated area. For water engineers, water conservation

means decreasing water losses in unproductive directions or increasing supply from lost resources. In a recent water conservation campaign, water conservation was defined as using the amount of water available in the most efficient way (Abu-Taleb et al., 1999). In addition there are growing environmental concerns over application of irrigation water resulting in leaching of nitrates and subsequent groundwater contamination.

Today efficient crop management does not necessarily imply in increasing the time and labor costs. Geographic Information Systems (GIS) tools can be an efficient technique for crop-water management. An integrated GIS software system is designed to quantify and allocate water for crops without causing yield reduction. A user can employ the GIS tool without understanding the complex physical processes and details of the phenomena that the model simulates. In the United States' current and future trends are increasing the efficiency of production, implying production with more efficient use of resources.

### **1.3 Why Use GIS**

The difficulty with the management of agronomic farms has been the diversity of data, their spatial and time variability and complexity of their analysis. "GIS is a Technique Oz", (Berry, 1991). It is today's most efficient way to manage spatial information for decision-makers.

Geographic Information Systems can greatly simplify data interpretation. It consists of a powerful set of tools that include collecting, storing, retrieving at will, transforming and

displaying spatial data in a form of human compatible products consisting of maps and tables, thus making the data readily accessible and easy to understand. Alternative options can be analyzed and used for decision-making. GIS must be thought of as being much more than just a means of coding, storing and retrieving data about the earth's surface. It represents a model of the real world. Because these data can be accessed, transformed, and manipulated interactively in a GIS, they can serve as test beds for studying environmental processes or for analyzing the results of trends or of anticipating the possible results of planning decisions.

The foundation of the current "revolution" lies in the fact that extensive field variability exists with regard to numerous yield-limiting factors. Such variability has long been recognized by both university and industry agronomists (Heuvel, 1996). Only recently have all of the tools been available to begin managing these factors. Such tools include affordable, fast computers with memory capacity to store large amounts of data for efficient processing, mapping and analysis of agricultural data.

In the past maps were primarily descriptive. They showed the precise placement of physical features. Increasingly, maps have become prescriptive showing the spatial interrelationship among mapped data and serve as data in determining appropriate management actions.

In this research, GIS is used to relate crop productivity to soil conditions and field inputs allowing spatial mathematics to model irrigation scheduling and water allocation in the construction of prescriptive maps for effective planning and management of farm activities.

The project aims to develop a methodology and management tool for data acquisition, storing, processing, analysis and display of the geographically related data. Through this data analysis, agricultural managers will be able to effectively organize, update and query detailed map data about their fields. It will enable them to identify spatial and temporal crop production, to analyze crop performance based on different soil types, water holding capacity and infiltration rate. They will be able to geographically access how the scheme is performing on a daily basis.

### **1.4 Objectives**

The goal of this research is to develop a GIS-based crop management system for irrigated crops, which can be implemented by farmers to maintain or increase yields, while conserving water. Specific objectives of this research include:

- 1) The development of a GIS-based irrigation scheduler to recommend the amount and timing of irrigation applications on a daily basis, considering spatial variability, and differences in resistance to crop-water stress.
- 2) The development of a crop-water priority system based on crop's sensitivity to water stress.
- 3) The development of a water allocation routine to satisfy crop water requirements using available water and system's physical capacity.
- 4) The development of a GIS system that can be easily used by the decision maker in charge of the farm system.

## **1.5 Literature Review**

### **1.5.1 Irrigation Scheduling**

Irrigation Scheduling is a procedure for predicting the time and amount of the next irrigation. Knowing the current soil-water depletion and an estimate of the future crop water use, the time when the depletion reaches any specified level can be calculated (Buchleiter, Duke and Heermann, 1992).

Scheduling provides managers with information to develop rational irrigation strategies for each field on the farm. Such strategies require information about the crop, soil, climate, water availability, irrigation system and water deliveries and management objectives. In addition, conflicts and trade-offs must be anticipated in time to make adjustments.

Conventional irrigation scheduling techniques do not consider the spatial-temporal processes of field soils and crop response to water. In such heterogeneous field soils, crop response to a set of soil properties change through space. Variation in soil means variation in the available water capacity of the soil and crop yield.

Crop-response varies within a field because the underlying crop growth processes and their response to concomitant soil processes are variable in space (Nielsen et al., 1999) and time (Stafford, 1999). Mapping and analyzing variability in field conditions, and linking such spatial relationship to management action places crop production with water use efficiency at the cutting edge of GIS application.

There is limited research dealing with irrigation scheduling techniques considering the spatial-temporal variability of crops (Paul, 1998). A precise and objective scheduling is difficult to achieve without considering both the spatial and temporal nature of crop response to change in soil properties.

When adequate water supply is assured, irrigation can be scheduled to saturate the crop root zone depth, up to the field capacity, and the timing of irrigation maybe estimated by the time it takes for the soil moisture to deplete to the critical level. Such an irrigation schedule ensures that the crop will grow at its potential rate provided all other agricultural inputs are supplied at optimal levels. When the available water is not adequate to meet the crop-water demands, water deficits during some periods cannot be avoided (Paul et al., 2000). Because crop-water response to water deficits at different periods is not uniform, it becomes critical for irrigation managers to decide how best to distribute the deficits among the crops, requiring the use of an irrigation scheduling technique to optimize water use while minimizing yield reduction.

Irrigation scheduling involves both updating field information and forecasting the future irrigation date and amount. Scheduling is not completed without both processes.

### 1.5.2 Water Allocation

Water is a limiting constraint to agricultural production in many areas. In a situation of increasing water scarcity and growing competition for water of good quality, effective

and sustainable management of water is the only way for feasible and competitive agriculture practices.

Increasing productivity of land and water resources, in an environmentally sustainable way is a challenge for irrigation project performance studies everywhere (Amarasinghe et al., 1998; Bastiaanssen et al., 1999; Sakthivadivel et al., 1999). Under conditions of limited water supply and variable rainfall, accurate irrigation scheduling techniques must be used to minimize yield reduction and to optimize sustainable use of the available water.

The problem becomes more complicated when a limited amount of water is to be allocated to a number of crops over the growing period. A deficit occurring in a certain stage of crop growth may cause a greater reduction in yield than the same amount of deficit occurring in some other growth stages (Paul et al., 2000).

During the past years many studies have been published on the optimal use of limited irrigation water, namely Hanks (1983) and Ghahraman and Sepaskhan (1994). In water-limiting situations, the producer faces a choice of spreading the available water over all cropland or irrigating only part of the land with more water (Martin and Gilley, 1993). The increasing demand for scarce water supply makes it imperative to improve water management.

On-farm water allocation involves decision on how water will be apportioned among the different crops to be grown within a farm. The amount and schedule to apply water must be consistent with the physical constraints of the delivery system such as maximum conveyance capacity or limited water supply.

Allocation strategies for limited water availability includes:

- 1) Allocating less water to more stress tolerant crops;
- 2) Selecting crops and planting dates to stagger the critical demand periods;
- 3) Irrigating crops during critical growth stages;
- 4) Analyzing yield tradeoffs.

Most farming situations are concerned with several crops grown in the same season. Both allocation of land and water resource under a multicrop situation in a season should be considered (Paul, 1998). There is no one single best allocation scenario when water is limited. Yield response to water stress differs for each crop, so a single optimal water management strategy is not the best for all crops simultaneously.

The degree of water deficit that will be allowed is a very important consideration when establishing crop priority to get water. Deficit irrigation requires suitable and reliable crop-water stress indicators because the effect of water shortages at certain crops' critical growth stages can be quite pronounced. Drought resistance crops commonly grown under deficit irrigation are less sensitive to critical phase deficits than drought sensitive crops.

### 1.5.3 GIS Modeling for Precision Farming

Within the past 15 years, technologies have been developed to help farmers better manage each of their fields utilizing spatially varying prescription intensities based on localized plant growth requirements or deficiencies (Robert et al., 1995; Mulla and

Schepers, 1997; Stafford, 1997). Recently, agricultural consultants have imported spatial and temporal field data into GIS to produce spatial distribution maps for improved on-farm management alternatives.

A complete and objective analysis of an entire irrigation system is very difficult to achieve using traditional data-collection techniques because of lack of detail on the spatial distribution of crop yield, soil variability and crop evapotranspiration.

Nowadays, Precision Farming makes sense to many farmers extending our traditional understanding of farm fields from "where is what" to analytical renderings of "so what" by relating to variations in crop yield, field and moisture conditions, (Mangold, 1999). What makes Precision Farming possible is the use of GIS and related spatial technologies to properly locate and map variation in agronomic characteristics across the field, including soil texture, vegetative cover, crop yield and moisture conditions.

At the heart of Precision Farming lies site-specific management, which involves the ability to collect and control information to accurately and appropriately address parts of fields for actual needs, rather than whole fields for average needs. Spatial-temporal field and crop processes are important for site-specific managers (Cassel et al., 2000). Site-specific managers use information technologies to turn their data into decisions. They must inventory practical variability within their fields, investigate probable causes, and instigate possible solutions to address management opportunities on a site-specific basis and evaluate the whole process. Precision Farming provides tools for real time, on-farm research. As a result, farmers have the potential to produce food and fiber more

efficiently. Site-specific application of irrigation water offers opportunities to conserve water and to reduce plant stress (Camp and Sadler 1998).

How a field is partitioned into smaller subunits plays an important part in Precision Farming. These smaller field areas are treated as homogeneous. Sampling analysis and management decisions are undertaken for each distinct subunit as if they were separate mini-fields. Site-specific management drives farmers to accurate record keeping, which will direct their decisions. Precision Farming is applying the right amount at the right time and at the right place, (Berry, 1998a). The approach includes assessing and reacting to field variability by tailoring management actions to match changing field condition.

Until mid 1990's, maps played a minor role in production agriculture. Most soil maps and topographic sheets were too generalized to apply at the farm level. As a result, the principle of whole field management based on broad averages of field data, dominated management actions. Precision Farming however is poised to change this view. Whole field management uses typical conditions to guide a single decision for an entire field. Site-specific-management, on the other hand, recognizes the spatial patterns within a field and adjusts inputs based on the combination of conditions at each micro-location throughout the field (Berry, 1999). It implies that the application of the input will not be uniform, but analyses of variability, which can be either spatial or temporal in nature, may warrant such an application. With this definition in mind, a farmer that is using irrigation scheduling is practicing Precision Farming (Heuvel, 1996).

GIS maps the field data so a farmer can spatially visualize the condition throughout a field, deriving a "prescription map" of management actions required for each location in

the field. By viewing a map, all sorts of potential relationship between yield variability and field conditions spring to mind. For example, a prescription map for water allocation is constructed by noting the existing soil-water depletion level and crop stress tolerance to water shortage (condition) then assigning different quantities of water to each location in the field or within a field (action), an "If (condition) Then (action)" set of rules (Berry, 1998b).

In theory, spatial modeling evaluates the relationship established among the analyzed data to determine "optimal" actions such as the quantity of water to be applied to each location in the field.

GIS has evolved rapidly within production agriculture. In less than 10 years the application has moved from inception to operational reality. Weather remains the number one variable farmers deal with every day. They can't control that variable, but they can seek to understand how to plan and manage variability and quantify and understand risk as a fact of business. As a result, farmers are the front-line integrators of information and technology (Mangold, 1998). They're turning information technologies and geographic information systems into geographic management systems as part of a toolbox of overall farm management tools and techniques aimed at reducing risk and optimize efficiency.

Valuable insight is gained by visualizing field variability. In the information age, a farmer's ability to react to inherent variability within a field might determine survival and growth of tomorrow's farm.

#### 1.5.4 Irrigation Scheduling and On-Farm Water Allocation Models

The development of a GIS-based on farm water allocation system (an irrigation scheduling and water allocation model) is a fairly recent evolution. The spatial variability of the crop productivity, the soil and applied water is a very important factor to be considered in irrigation scheduling and water allocation priority because some part of an irrigated field will usually show signs of stress before others. When managing a field for some planned level of stress, it is therefore necessary to determine not only when stress occur in the field but also what proportion of the field (subunit) is under stress. Consequently scheduling methods that depend upon spot samples (field average) are not very reliable.

A review of the literature suggested that several models focused upon elements within the crop management domain have been developed, however they did not consider spatial variability. Many computer programs have been developed for computation of crop water use and automated irrigation scheduling.

Examples include SCHED (Buchleiter, Duke and Heermann, 1992) produced by USDA-ARS. It is a DOS based program that uses techniques developed by Kincaid and Heermann, (1974), for microcomputer application, and incorporates improved methods of estimating clear sky solar radiation (Heermann, Harrington and Stahl, 1984) and crop coefficients from Duke (1988). The program uses logic similar to that reported by Heermann, Haise and Michelson (1976) for scheduling irrigations under center pivot irrigation systems. This reference provides a detailed explanation of the irrigation

scheduling logic. It computes field-by-field or regional crop evapotranspiration using Penman equation, Jensen-Haise equation or direct input of reference  $E_t$ . The actual water use is calculated by multiplying the reference  $E_t$  by a crop coefficient.

Michigan State University has developed the SCS-Scheduler (Shayya and Bralts, 1991) to assist on-farm managers in making the decision "When should irrigation begin and how much water should be applied?" It is part of a continuing effort to help farmers schedule irrigation water application effectively. Using farm characteristics and local weather data, the computed root zone water balance method is employed for water budget updates and irrigation scheduling. The soil water content is determined daily by adding rain and irrigation amounts and subtracting evapotranspiration. Soil water characteristics required by the program are site specific and must be provided by the user. Weather data maybe entered manually to the computer or transferred directly from a local weather station. The producer supplies rainfall and irrigation measurements.

To predict soil water for a given field, SCS-scheduler requires an initial estimate of the available water capacity of the soil, daily climatic data to determine crop evapotranspiration, and daily precipitation records. The method used to estimate evapotranspiration involves the following equation:

$$ET = K_d (K_c E_{t0}) \quad \text{Eq. 1}$$

Where  $E_{t0}$  is the reference evapotranspiration calculated using the FAO-modified Penman equation (Doorenbos and Pruitt, 1977),  $K_d$  is a coefficient which is function of the available water capacity of the soil,  $K_c$  is the crop coefficient which is function of the growth stage of the crop and  $ET$  is the crop evapotranspiration.

Utah State University has developed REF-ET (Allen, 1990), which is a reference evapotranspiration that provides standardized calculation of average daily reference evapotranspiration (Et). REF-ET use guidelines and procedures recommended in ASCE manual 70, Evapotranspiration and Irrigation water requirements (Jensen et al., 1990). Eight Et-ref methods are computed for both grass and alfalfa references.

They are:

- 1) Penman-Monteith with resistance equation by Allen, 1990
- 2) 1982 Kimberly Penman (Wright, 1982)
- 3) FAO-24 Corrected Penman (Doorenbos and Pruitt, 1975)
- 4) 1963 Penman (Penman, 1963)
- 5) 1985 Hargreaves Temperature Method (Hargreaves, 1975)
- 6) FAO-24 Radiation Method (Doorenbos and Pruitt 1975, 1977)
- 7) FAO-24 Blaney Criddle Method (Doorenbos and Pruitt, 1975, 1977)
- 8) FAO-Pan Evaporation Method (Doorenbos and Pruitt, 1977)

The Land and Water Development Division of FAO developed CROPWAT. It is a computer program to calculate reference evapotranspiration, crop water requirements and irrigation requirements (Smith, 1992). CROPWAT is meant as a practical tool to help agro-meteorologists, agronomists and irrigation engineers to carry out standard calculations for evapotranspiration and crop water use studies, and more specifically the design and management of irrigation schemes. Procedures for calculation of the crop water requirements and irrigation requirements are based on methodologies presented in

FAO Irrigation and Drainage paper No.24 "Crop water requirements" (Doorenbos J., et al, 1992) and No. 33 "Yield Response to Water" (Doorenbos and Kassam, 1991).

Cranfield University, Silsoe College (Hess, 1994) developed IMS. It is an interactive computer program for day-to-day scheduling of irrigation. It has been developed and tested for the irrigation of potatoes, sugar beet and a range of vegetable crops. The program uses 'water balance' approach that combines information on the crop, soil and weather and estimate a soil water deficit. Irrigation is scheduled according to an allowable deficit, set by the user that maybe varied through the season. In order to run the program it is necessary to specify some background data relating to the crop and soil. For the program to estimate the rates of water use by the crop, daily data are required relating to the weather. In addition, rainfall and irrigation applications must be measured each day on the farm. The output from the program consists of clear, concise information on when the next irrigation will be required, based on the current soil moisture status and the expected crop water use over the next 10 days.

Cranfield University, Silsoe College (Hess, 1997) also developed IWS. The program can be used to estimate long term irrigation requirements and year to year variability, based on actual weather data, evaluate the interaction between irrigation equipment and scheduling and evaluate the impact of sub-optimal irrigation (inadequate scheduling) by the relative reduction in actual evapotranspiration. The output from the program includes daily irrigation amount, crop transpiration, soil water storage and effective rainfall. For each year of simulation, a summary is produced of the number of irrigation, total net irrigation requirement and relative yield.

Vedula and Nagesh Kumar (1996) developed a mathematical programming model to determine the steady-state optimal operating policy and the associated optimal-crop-water allocation for all the crops for a single purpose irrigation reservoir, combining linear programming and stochastic dynamic programming.

Sunantara and Ramirez (1997) developed an optimal seasonal multicrop irrigation water allocation and optimal stochastic daily irrigation scheduling using a two-stage decomposition approach based on stochastic dynamic programming.

As already mentioned before, none of the above-discussed models have considered spatial variability or used GIS techniques to perform crop and irrigation management operations. As farmers start to work with geographic information system (GIS) software tools they begin to analyze data to make site-specific decisions.

## **1.6 An Overview of the Project**

### **1.6.1 System Design**

Deficit irrigation is the scheduling method applied under a restricted water supply, where irrigation does not fully cover the water requirements of the crop and where certain stress conditions are allowed (ICID-FAO, Smith et al. 1995). The objective is to optimize yields by allocating a limited water supply to the most sensitive stage of crop growth. It requires reliable estimates of soil water content and crop water stress tolerance.

Using conventional practices, farm managers tend to treat a field as a single unit and manage the field to optimize the average production of the field as a whole. In order to avoid influences of spatial variability a widely accepted assumption was that existing field soil variability could be compensated for by a large number of replicated plots. The idea behind Precision Farming is that by breaking the field into several subunits and treating each unit independently, the production of each unit can be optimized, rather than treating the entire field as an average (Thompson, 1999). Precision Farming incorporates GIS and spatial technologies allowing farmers to manage each parcel of land in a manner consistent with its unique endowments (Batte, 2000).

The system, which has been developed in this research, is the first attempt to combine a GIS-based irrigation scheduling with a water allocation model into a single decision support package. The software utilizes an ARC/INFO platform and is written in ARC macro language and INFO language. The model has a complete screen based windowing environment. The system runs on a UNIX platform. The model has complete mouse as well as keyboard support.

The information utilized in this research was compiled from soil conservation and land use maps provided by the Larimer county soil survey and ARDEC farm soil description and land use survey, and other current available literature (see references at the end of this report). The crop management system consists of three modules:

- 1) Water budget with forecast
- 2) Crop-water priority setting
- 3) Water Allocation

The irrigation scheduler uses a traditional soil water mass balance approach and the concept of management allowable depletion level to trigger irrigation recommendations. The system operates in real time mode using daily weather data to estimate crop evapotranspiration and forecast irrigation requirements.

Management allowable depletion levels can be selected for each crop growth stage. The stage of crop development, daily crop coefficient and irrigation decision calculations are estimated for any growing season day. Reference Et is a direct input from a different source. The irrigation scheduler has been developed to be used with any crop for which crop coefficients are available.

Under limited water supply, the relation between relative yield reduction and relative evapotranspiration deficit is of paramount importance in the determination of the plots to be irrigated

### 1.6.2 Water Allocation Priority Decision Algorithm

Water shortages have become more frequent and farmers often face deficiencies in water deliveries, resulting in reduced yields and incomes. Optimizing the allocation of the available water will raise yields, and in turn will lead to higher incomes. Furthermore, poor management of available water for irrigation, both at system and farm level, has led to a range of problems and further aggravated water availability, and has reduced the benefits of irrigation investments (ICID-FAO, Smith et al., 1995).

Deficit irrigation results in crop water stress and reduced crop yields. Scheduling for deficit irrigation is potentially more challenging than for full irrigation. Ideally the decision-maker should evaluate not only the amount of water remaining in the soil profile but also the level of stress which the crop is experiencing and how that stress will affect yields.

Crop water requirements cannot be fully met when water availability is insufficient. Furthermore variability in crop water requirements is function of location and irrigation method used (Al-Jamal et al., 2000). Different crops respond in a specific manner to the deficit of water depending on the crop development stage and tolerance to water stress. Pereira (1994) presents a contemporary review of the different existing equations. Jensen (1968) proposes a multiplicative equation for crop sensitivity as function of individual crop growth periods. Hiler and Clark (1971) and Stewart et al. (1977) have proposed cumulative equations. These models have also been later proposed by FAO (Doorenbos and Kassam, 1979 and 1991).

Crop-yield is primarily water-limited in many areas. In this research the irrigation water allocation priority uses the relation between yield reduction and relative evapotranspiration deficit in the determination of the plots to be irrigated. The relation is given by the empirically derived yield response factor ( $K_y$ ) (Doorenbos and Kassam, 1991), which is based on the following equation:

$$1 - Y_a / Y_m = K_y * ( 1 - E_t / E_{tm} ) \quad \text{Eq. 2}$$

Where:

$Y_a$  = actual yield (tons / hectares)

$Y_m$  = maximum yield

$E_a$  = actual evapotranspiration (mm)

$E_m$  = maximum evapotranspiration (mm)

$K_y$  = crop yield response factor (crop and growth stage specific)

When  $K_y$  factors are above unity, a reduction in actual evapotranspiration/potential evapotranspiration results in a larger reduction of yield than when  $K_y$  is less than unity. Therefore the amount of water necessary should be delivered to the crop with the larger  $K_y$  to ensure that actual  $E_t$  equals potential  $E_t$ . A crop with high  $K_y$ -value will suffer more from water stress than a crop with lower  $K_y$ -values, resulting in greater yield losses when crop-water requirements are not met.

Each crop has a different value, therefore, allocation of the available water resources also depend on factors such as net profit per unit yield, potential yield of the crop and the minimum depth of irrigation water needed for obtaining a potential yield. Consequently a limited water supply should be allocated to a crop with higher economic value.

When water stress occurs, crop growth and yield formation is affected. The yield decreases as a result of water stress depends on crop species on one hand and on the magnitude and duration of water stress on the other. Not only do crop species vary in their response to water deficits, but also each crop reacts differently to water deficits in its individual growth stage. In general crops are more sensitive to water stress during flowering and yield formation than they are during early (vegetative, after establishment) and late growth stages (ripening). This is shown in table 1.1 representing  $K_y$ -values for different crops and their individual growth stages.

The Ky-values are based on experimental field data covering a wide range of growing condition and represent the response of crop varieties well adapted to the growing environment and grown under a high level of crop management, i.e., adequate inputs are provided except for water.

Knowledge of Ky-factors for individual growth stages can be used to direct a limited supply of irrigation water toward meeting the full water requirement of a crop during their most sensitive growth stages.

**Table 1.1 Ky -- Yield response factor for crops at different stages of grow**

<b>Ky -- Yield response factor</b>				
<b>Crop</b>	<b>Period # 1 Vegetative</b>	<b>Period # 2 Flowering</b>	<b>Period # 3 Yield Formation</b>	<b>Period # 4 Harvest</b>
<b>Alfalfa</b>	0.9	0	0.1	0
<b>Beans</b>	0.2	1.1	0.75	0.2
<b>Corn</b>	0.4	1.5	0.5	0.2
<b>Pasture</b>	0.1	0	0.1	0
<b>Potatoes</b>	0.8	0.6	0.7	0.2
<b>Small - Grain</b>	0.2	0.65	0.55	0
<b>Sorghum</b>	0.2	0.55	0.45	0.2
<b>Soybeans</b>	0.2	0.8	1	0
<b>Sugar - Beets</b>	0.8	0.8	0.8	0.8
<b>Wheat</b>	0.2	0.65	0.55	0

*Source: Modified from Doorenbos and Kassam (1991) - FAO Irrigation and Drainage paper*

## **1.7 Types of Maps Used in the Model**

There are two forms of data structures in a GIS system: Vector and Raster. Both have advantages and disadvantages. A raster-based system is initially storage intensive for entering the data but very efficient for analysis. A vector-based system initially has low storage requirements, but analyses require very large storage capacity and CPU. It is more detailed and provides a more accurate picture of the irrigation requirement in a small farm such as ARDEC. This entire research is performed using a vector GIS system.

The database subsystem can be divided into:

### 1) Static database (base maps)

The base maps are the ones digitized directly from existing county planning maps of the study area. In general, base map layers show the physiographic features, roads and rivers network, the geographic and hydrologic boundaries, soil types, irrigation systems, topography etc., which are some of the important elements in any soil-crop production planning. Most of these maps are static data, that is, it does not change significantly with time

### 2) Dynamic Database (descriptive, interpretative maps)

These include crop type maps, crop acreage maps, land use etc. These maps have a dynamic characteristic in the sense that they are continually changing with time.

## **1.8 Procedures and Work Plan**

The work plan for this research is divided into three stages, they are:

Project stage 1: Determine the objectives and build the geographic database

Project Stage 2: Modeling, performing geographical analysis

Project stage 3: Presenting the results of the geographical analysis

### **Project stage 1: Determine the objectives and build the geographic database**

The first stage of this research includes determination of the objectives, data collection and data entry into the system. As stated in previous chapters the objective of the proposed research is the development of a GIS-BASED management tool for irrigation scheduling and Water allocation to manage crop production.

This stage is the most time consuming part of the project. The completeness and accuracy of the database determine the quality of the analysis and final products. The steps involved in the development of the database are:

Designing the data base: it consists of determining the study area boundary, the coordinate system to be used, the data layers needed and the features necessary in each of them, coding of the attributes and their organization. The layers of this research are illustrated in figure 1.2.

Once the data layers for the project are identified we proceed with the definition of the attributes needed for each feature. Attributes will be stored as numbers and/or characters according to the specific objectives. Before the definition of the attributes, it is necessary

to convert features in a map to a digital format on the computer. This involves digitizing the maps needed to create the GIS database of the study area necessary for analysis, a procedure that consists of manually tracing all features on a map.

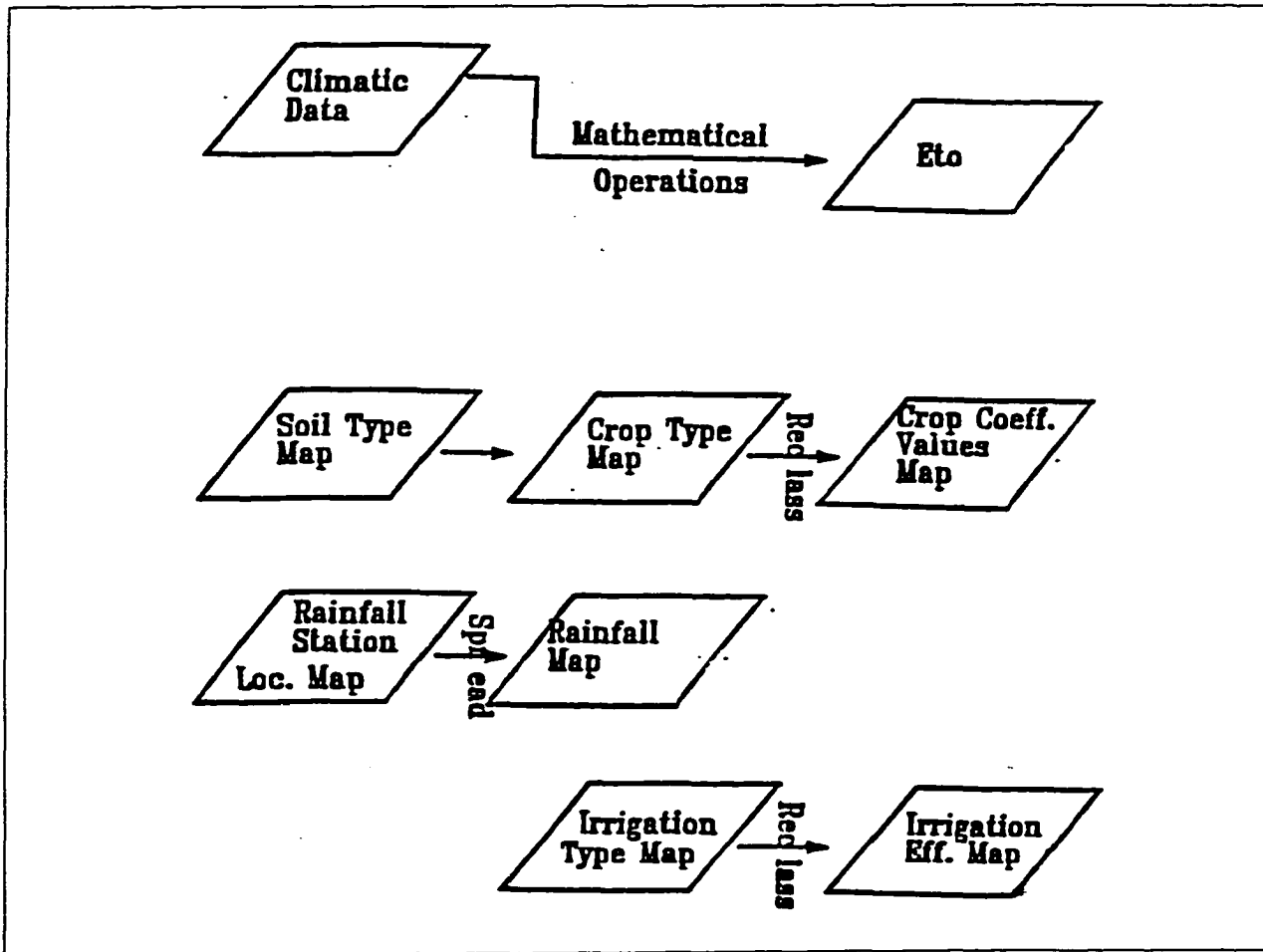

**Figure 1.2 Map layers for the GIS**

The maps needed for the GIS database were provided by the ARDEC farm (1986) and by the Soil Survey report of Larimer County area in Colorado (Moreland, 1980). They were digitized into the system in vector format using the ARC/INFO software and then

edited to ensure that the map is free of errors. This is done by identifying and correcting errors such as arcs that do not connect to other arcs, polygons that do not close, undershoots, overshoots etc.

The next step in building the database is to add descriptive or numerical attributes to each of the digitized features. This is done by creating a data file associated to the digitized map, which contains information about points, lines or polygons in the map. Each record in the feature attribute data table will contain a description of one map feature of the digitized map. The maps attributes of the research area were found at the digitized maps and reports and at the ARDEC soil description, 1986 Fort Collins, Colorado.

At this point all the digitized maps and pieces are transformed to the same coordinate system. Adjacent maps (not layers) are then joined together into one big map encompassing the whole study area, in this case the ARDEC-farm. Figure 1.3 illustrates the GIS definition of a layer, feature type, feature class, and attributes. Having those definitions in mind it is easier to understand the modeling process of a Geographic Information System.

### **Project Stage 2: Modeling, performing geographical analysis**

Once the geographic database is completed, the second part of the project consists of modeling, performing geographical analysis. Each of the data layers in the database contains specific information required for the modeling. To satisfy specific objectives, mathematical operation within and between data layers is required. This is part of the modeling process.

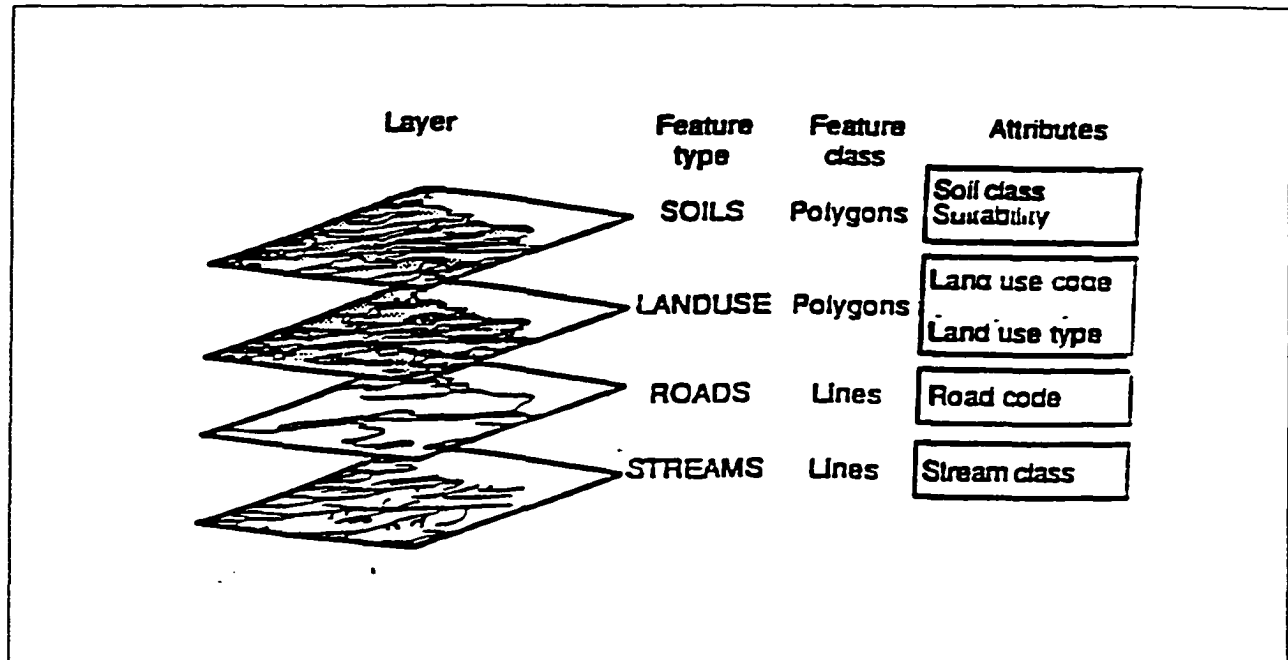
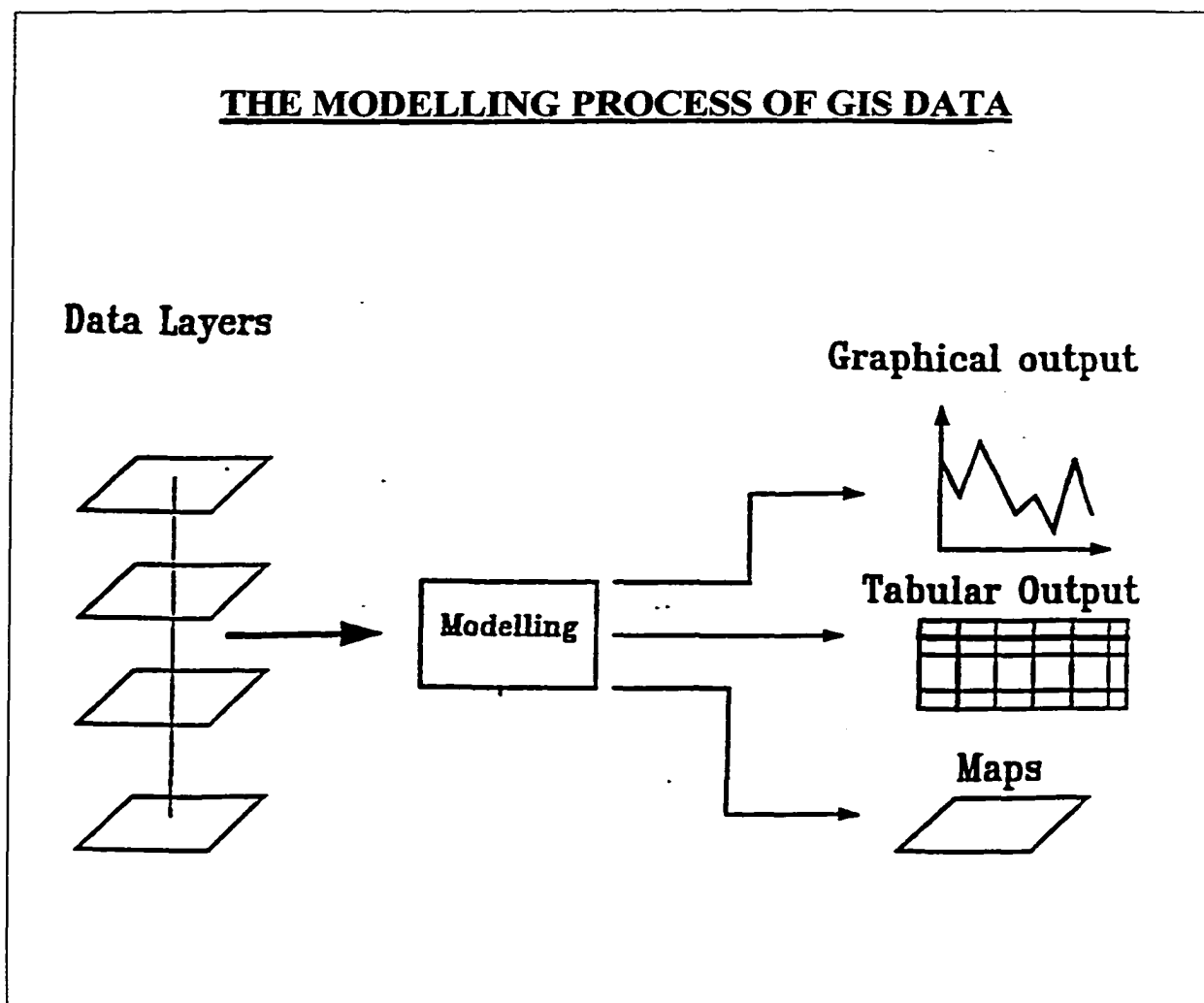

**Figure 1.3 GIS project layers and attributes**

Geographical analysis (modeling) can be performed through the following steps:

- 1) Establishing the objectives and criteria for the analysis
- 2) Selecting the data layers to perform spatial analysis; crops, irrigation systems, soils, land use in general
- 3) Performing the spatial analysis (modeling) using mathematical functions within the GIS. This includes reclassifying, overlaying, distance measurements' operations, irrigation scheduling algorithms and irrigation water requirements parameters.

The GIS based models will generate new information which will further help us understand the inter-relation of the physical, biological and economic factors of a farming system thus increasing our understanding of the real world (figure 1.4.).



**Figure 1.4 The modeling process of GIS data**

**Project stage 3: Presenting the results of the geographical analysis**

One very important aspect of a GIS system is its ability and resources to display results in an easy to understand way. The research results can be displayed through maps, tables and graphs customized for specific purposes.

## **1.9 Technology Transfer**

The intention of this research is to provide the agricultural community with a planning and management tool that can be used to produce different management scenarios that optimizes farm production.

At the present moment there isn't any computer package available for irrigation scheduling and water allocation that takes into consideration spatial characteristics of the crop fields and soils and much less, that uses Precision Farming (site-specific management) for irrigation water management. Precision Farming technique by itself is still in a development phase (Thompson, 1999).

Farmer's acceptance of this crop management system will be largely based upon the ease with which it can be used. The system is designed to provide a user-friendly environment.

## **CHAPTER 2**

### **IRRIGATION SCHEDULER STRUCTURE**

#### **2.1 An overview of the Irrigation Scheduler Model Design**

##### **2.1.1 Model Objectives**

Improved water management objectives require a determination of timing and amount criteria for applying water. Numerous models using various types of criteria have been developed for irrigation scheduling but none of them has taken into account the spatial variability of the data. Examples of these models are described in chapter 1, item 1.5.4, of this research.

The best schedule is the one that integrates spatial and temporal variability to decide when and how much water to apply. The purpose of this GIS-based Irrigation Scheduler model is to provide real time irrigation scheduling advice for an irrigated crop using spatial tools. The program operates on a daily-time step basis. It performs a soil water mass balance in order to calculate the soil water within the root zone. Based upon the soil water status, the program recommends the timing and amount of irrigation water that

should be applied in order to maintain the soil water above a management allowable depletion throughout the growing season.

Soil water calculations are not performed for dates outside of the growing season. The program will not recommend an over irrigation that would raise the soil water above field capacity because such a recommendation conflicts with the goal of minimizing excessive water use. If the irrigation system is constrained by fixed supply of water the recommendation can be adjusted by manually entering the amount of irrigation delivered to that specific field or just specifying if an irrigation has occurred or not. The model recalculates the new soil water content in the root zone.

The model uses a layered mass balance approach. It takes into account the concerns of spatial variability of soil water infiltration across the field and throughout the root zone. Reference evapotranspiration values are obtained from a different source and are entered direct into the model. It is calculated using the user's choice of Et estimation methods.

Because of the time lag of meteorological information, the soil water cannot be determined for a given day until that day has passed. This constraint is a consequence of the reference evapotranspiration estimation's dependence upon full weather parameters. The result of this constraint is that the program must be able to forecast the following day's soil water status and predict timing and amount recommendations more than one day in advance. The program recommends irrigating if the current soil water depletion exceeded the management allowable depletion. The recommended application amount is determined from the current deficit in order to bring the soil water back to field capacity.

The user is under no obligation to follow this recommendation, and if he or she does not, the program will illustrate the soil water consequences.

### 2.1.2 Forecasting Evapotranspiration Amount

The model developed in this research has an option to forecast the evapotranspiration. The advantages of forecasting irrigations in advance are to estimate water requirements and integrate with other necessary farming operations. By estimating the need for irrigation and use of future weather forecasts, one can estimate the timing of the next irrigation. The use of estimation and forecasts has the advantage of predicting into the future as compared to just measuring the indicator of need for irrigation and reacting accordingly. In this research, irrigation forecast was done using an exponential function, (Heermann and Jensen, 1970).

$$Et_{ref} = Et_{rp} \exp\left[-\frac{(t-t')^2}{\Delta t}\right] \text{----- Eq. 3}$$

Where:

$Et_{ref}$  = the forecast reference Evapotranspiration, mm

$Et_{rp}$  = peak reference Et, mm/day

t = day of the year

t' = day of the year on which  $Et_{rp}$  occurs

and delta t = days before and after t' when  $Et_{ref} = 0.37 * Et_{rp}$

### 2.1.3 Model Design Philosophy

The model was designed to be user-friendly and easily adaptable to a user's preference and situation. It has a concise informational organization scheme. The model was developed to be as precise as possible, giving consideration to capabilities, performance and speed.

"The farm community doesn't want to become entrapped by data-driven technologies; they expected to be empowered with decision making tools" (Berry, 1999). The objective of this research was to provide users with a tool that could be utilized to schedule irrigation within a season on a daily basis. It is designed for any crop species or soil type. Information is organized by year, location, farm and field. It accounts for all spatially and temporal variability present.

A location refers to any geographical area, which can be represented with one or more sets of meteorological data. Consequently, the model can deal with different reference evapotranspiration values for a farm. The size of the geographical area associated with a location can vary and should be determined by the user.

When a farm designated within the location is represented by more than one weather station or a data collection point within the location, a method of interpolation using boundaries is employed by the Thiessen polygons' theory and used by the GIS program to apportion a point coverage containing the geographical location of each weather station or data collection point into regions known as Thiessen or Voronoi polygons (ARCINFO command references J-Z, 1998). The idea is that given a two-dimensional array of

sampling points, the ‘best’ information about an unvisited point can be gleaned from the data point nearest to it. This is an idea that all who uses climatic data will intuitively accept; in the absence of local observation one uses the data from the nearest available weather station. Thiessen polygons divide a region in a way that is totally determined by the configuration of the data points. If the data lies on a regular square grid, then the Thiessen Polygon are all equal, regular squares of side equal to the grid spacing; if the data are irregularly spaced then an irregular lattice of regions results.

Green and Sibson (1978) have produced a well-know algorithm for computing these cells, and Ripley (1981) has provided a mathematical discussion of the principles of tessellation involved. From the point of view of the user wishing to interpolate a value at unsampled points, the method has several drawbacks. First, the size and shape of the areas depend on a sample layout; this can lead to polygons having strange shape, particularly at edges. Second, the value of the property of interest in each cell is estimated by a sample of one, which is useless for gaining any idea of the error margins to be placed on that estimate. Third, computation of a value at an unsampled point becomes a point-in-polygon problem; it has nothing to do with our intuitive ideas that points close together are more likely to be similar than points far apart. Sibson (1980) has described a method called ‘natural neighborhood’ interpolation that attempts to overcome some of these problems by using weighted averages that are proportional to the tile areas (Ripley, 1981).

The Thiessen polygons are constructed as follows:

- 1) All points in the coverage are triangulated into a Triangular Irregular Network (TIN) that meets the Delaunay criterion.

2) The perpendicular bisectors for each triangle edge are generated, forming the edges of the Thiessen polygons. The location at which the bisectors intersect determines the location of the Thiessen polygon vertices.

3) The Thiessen polygons are built to generate polygon topology. The location of the “in cover” points is used as the label points for the Thiessen polygons. (Figure 2.1).

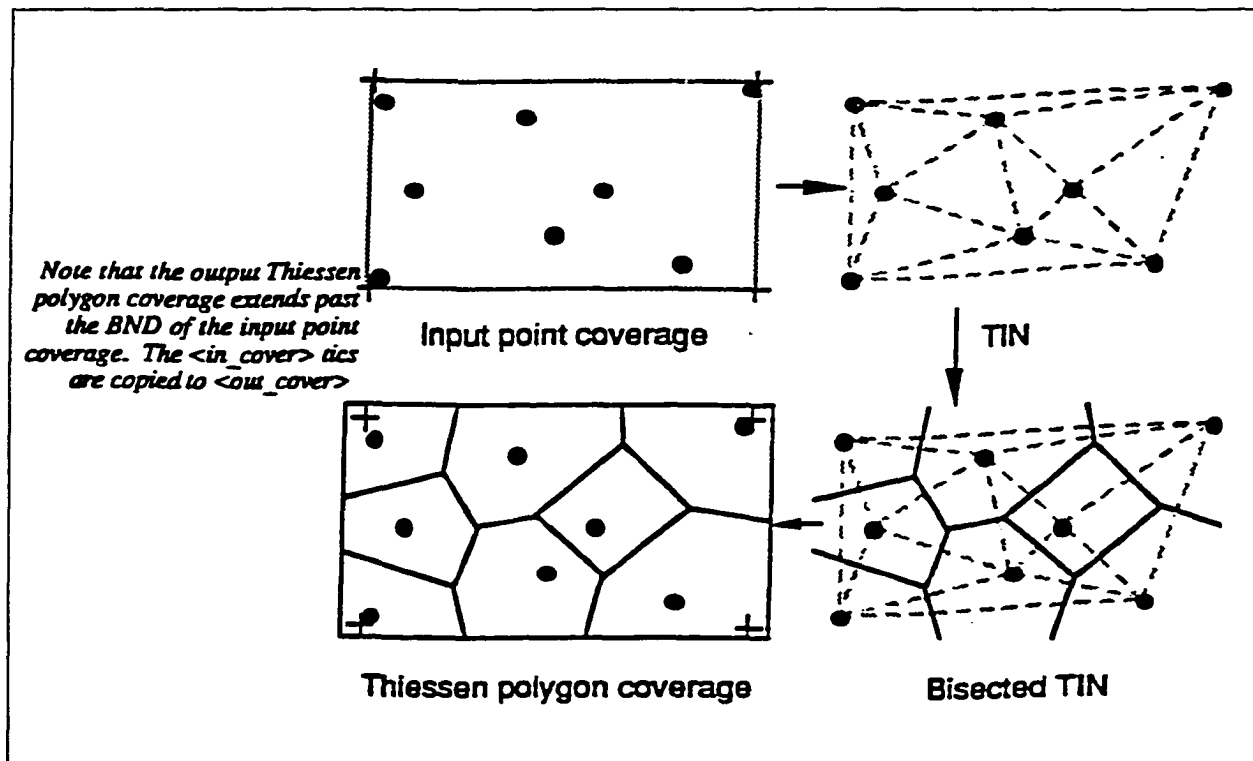
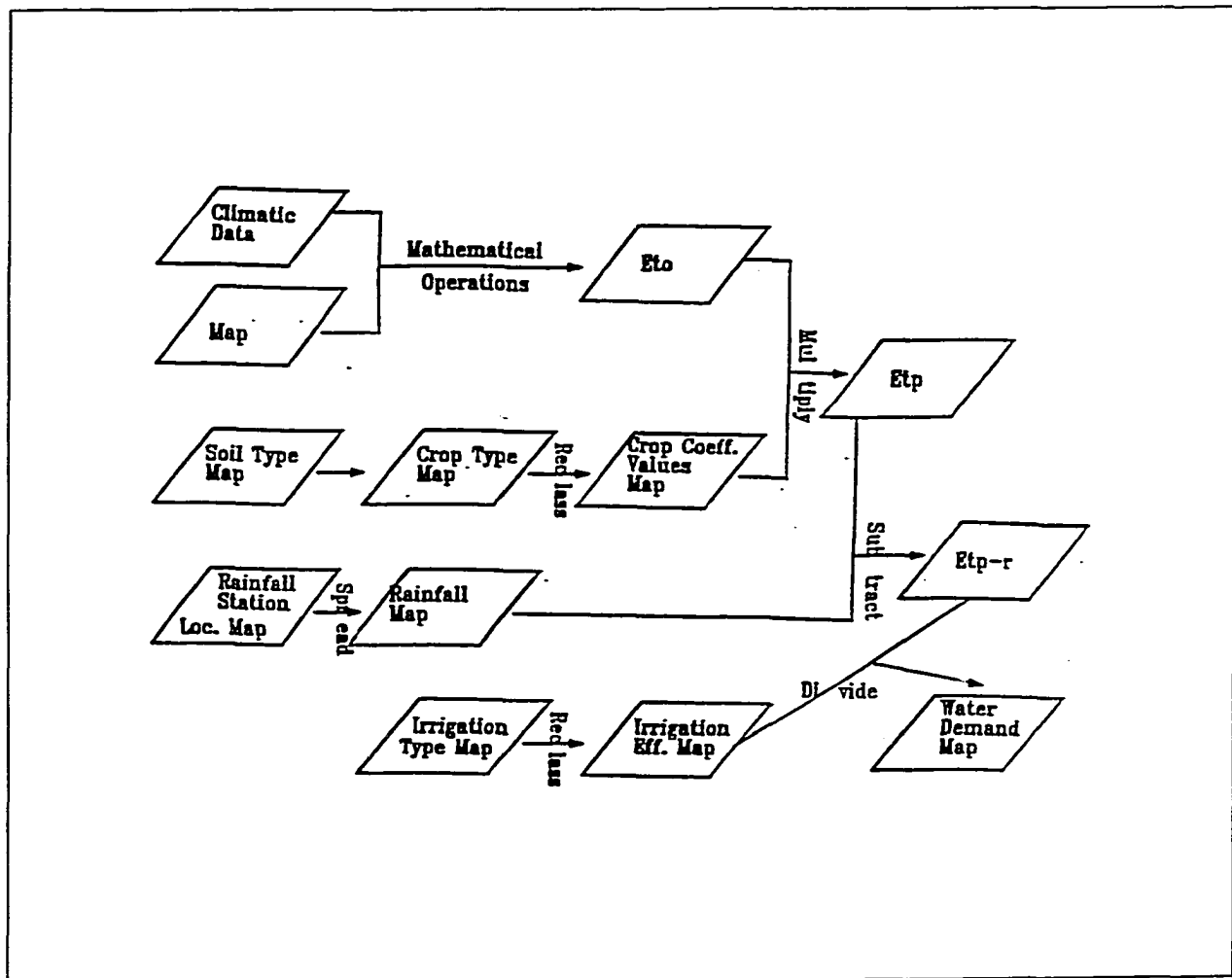

**Figure 2.1 Thiessen polygon construction method**

*Source: ARC/INFO command references (J-Z), 1998*

Rainfall data values obtained from a near by weather station are translated into an aerial precipitation map using GIS techniques (spatial interpolation). During the irrigation scheduling process this map is subtracted from the crop water requirement's map.

GIS is used to compute spatial and timely crop water requirements. A map is generated with crop-water requirements for each crop type. The crop-water requirements' map is multiplied by the crop-type area map to generate a map showing the volume of water required for each field and the entire farm. The irrigation efficiencies' for each field are mapped and the gross irrigation water demand is determined for each field. Figure 2.2 is a schematic of the GIS model.



**Figure 2.2 Crop evapotranspiration and water demand model**

A farm is a collection of fields associated with a location. The farm and fields have data characteristics of their own. The size of the farm file depends on the number of fields it contains. A field is the scheduling entity within a farm. It possesses information pertaining to the soil (WHC, PWP, FC, soil type texture, layers), crop (species, coefficients, rooting depth), irrigation system characteristics (type, efficiency). These data (attributes) need not to be manually entered into the system. They are stored in default tables that are spatially associated to each field in the farm. It also contains the daily information necessary to calculate the current soil water content and the quantity of irrigation water.

The meteorological information for a field is obtained from the weather station specifically designated for that field location as mentioned before, i.e., using the Thiessen Polygon method of interpolation theory.

#### 2.1.4 Model Assumptions and Considerations

The following assumptions and constraints are made:

- Water is a constraint to production
- The farmer's can apply variable amounts of water at variable timing
- The soil properties vary spatially across the field
- The soil water content is not constant spatially across a field. It can change as soil characteristics changes

-The soil properties can vary throughout the entire root zone. Soil and hardpan layers can exist

-The soil is well drained. There is no upward flow from ground water

-The crop coverage can spatially vary over the farm

-The crop water extraction varies in a field according to the soil characteristics

-The crop rooting depth increases from a planting date to a maximum depth at full cover

-The basal crop coefficient is represented as two segmented third order polynomials expressed as a function of the percent elapsed season days to full cover or the days since full cover, respectively

-The management allowable depletion remains constant within each growth stage. It can vary from one stage to another if desirable. Crop growth stages are divided into four and management allowable depletion values if not entered by the user are inherited from default databases as function of crop type and growing stage, thus varying from one stage to another

-The irrigation requirement efficiency varies spatially. It is function of the irrigation system type for that particular field. Values for irrigation efficiency for a particular field, if not entered manually by the users are taken from default tables.

-The initial soil water measurement should be taken at the time of starting the scheduling program so that the initial soil water adequately represents the soil water at planting

- The soil water content cannot be extracted below the permanent wilting point (PWP)

## **2.2 Calculations**

### **2.2.1 Soil Water Mass Balance**

The Irrigation Scheduler uses a layered soil water mass balance to calculate the soil water content within the root zone. The mass balance is calculated using a daily time-step and it accounts for any changes in soil characteristics in the profile following the crop roots growth, with the soil water expressed as depletion of water (water deficit) in the soil root zone. The soil water mass balance can be calculated for day (t) as (Buchleiter, and Heermann, 1987):

$$D(t) = D(t-1) + \text{Eta}(t) + E_w(t) - I_e(t) - R(t) + P(t) \quad \text{Eq. 4}$$

Where:

D = depletion in the root zone (m)

Eta = actual crop water use (m/day)

E<sub>w</sub> = evaporation from wet soil surface (m/day)

I<sub>e</sub> = Irrigation amount entering the soil profile (m)

R = Rainfall Amount (m)

P = percolation below the root zone

t = current day

t-1 = previous day

A clear understanding of all the terms of the water balance is essential for exploring water saving measures (Beyazgul et al., 2000). The effective precipitation must be input

directly by the user. An irrigation amount refers to the gross irrigation, which considers irrigation system efficiency to estimate “I<sub>e</sub>.” The reference E<sub>t</sub> that is used to calculate actual crop water use should be input into the model. It is calculated using one of the methods mentioned before. The soil water mass balance model permits proper representation of actual responses to irrigation water application and to rainfall and is considered to be essential for real-time application (Wardlaw and Barnes, 1999).

### 2.2.2 Description of Scheduling Algorithms

The scheduling algorithms are presented in this section. The soil-water deficit is estimated on a daily basis. Based upon this deficit, the need for irrigation is determined (Jensen, Burman and Allen, 1990).

The crop growth stage is calculated from the day of the year. It is determined by comparing the current day (DOY) to the growth stage range (Jensen, Burman and Allen, 1990). The range is between the start of a crop grow stage (DOY<sub>start</sub>) to the end of that crop stage (DOY<sub>end</sub>). When calculated from the day of the year:

$$\begin{aligned} \text{grow stage} &= \text{preplant} && \text{if } (\text{DOY})_t < (\text{DOY})_{\text{plant}} \\ \text{grow stage} &= (\text{grow stage})_i && \text{if } (\text{DOY})_{\text{plant-i}} \leq (\text{DOY})_t \leq (\text{DOY})_{\text{harvest-i}} \\ \text{grow stage} &= \text{post harvest} && \text{if } (\text{DOY})_t > (\text{DOY})_{\text{harvest}} \end{aligned}$$

The user can specify the crop growth stage or use the default. By comparing the current day (DOY) to the growth stage range contained in the default table (Table 2.1),

for specific crops a growth stage number is assigned to this crop following the algorithm specified above, as follows:

1= Vegetative

2= Flowering

3= Yield formation

4= Harvest

The basal crop coefficient,  $K_{cb}$ , quantifies the amount of consumptive use for a specific crop assuming that water is not limited and wet soil evaporation is not occurring.

**Table 2.1 Average crop development days in Colorado**

<b>Crop</b>	<b>Period # 1 duration-days vegetative</b>	<b>Period # 2 duration-days Flowering</b>	<b>Period # 3 duration-days Yield Formation</b>	<b>Period # 4 duration-days Harvest</b>
<b>Alfalfa</b>	10	20	20	50
<b>Corn</b>	10	65	40	30
<b>Dry Beans</b>	10	33	38	19
<b>Pasture</b>	10	20	80	73
<b>Potatoes</b>	20	20	80	50
<b>Sorghum</b>	30	40	35	15
<b>Soybeans</b>	30	47	15	31
<b>Small-Grains</b>	20	20	40	60

*Source: Calculated from the dates obtained from James Echols and Robert Crissant, Fort Collins and Richard Bartholomay, 1991 Grand Junction, Colorado State University Extension*

The basal coefficient is calculated as a segmented third order polynomial (Duke, 1991), based on elapsed time during the growing season it is calculated as follows:

$$\begin{aligned}
(Kcb)_t &= A_1R_t^3 + B_1R_t^2 + C_1R_t + D_1 && \text{Eq. 5} \\
(Kcb)_t &= 0 && \text{if } (DOY)_t \leq (DOY)_{plant} \\
(Kcb)_t &= A_1R_t^3 + B_1R_t^2 + C_1R_t + D_1 && \text{if } (DOY)_{plant} < (DOY)_t \leq (DOY)_{cover} \\
(Kcb)_t &= A_2R_t^3 + B_2R_t^2 + C_1R_t + D_2 && \text{if } (DOY)_{cover} < (DOY)_t \leq (DOY)_{harvest} \\
(Kcb)_t &= 0 && \text{if } (DOY)_t > (DOY)_{harvest}
\end{aligned}$$

Where  $A_1$  through  $D_2$  are empirical determined polynomial coefficients from Duke, 1991. Those coefficients are stored in default tables (table 2.2). When not entered manually by the user they are inherited from those databases by the program function of crop type and stage of growth.

Only planting and effective cover dates are used in computing  $Kcb$ , since crop-water use calculations terminate at harvest. Two sets of polynomial coefficients are required. The first set is applicable from planting to effective cover and the second set is applicable from effective cover until harvest. Before the effective cover date,  $R$  is the fraction of time from planting to effective cover. After the effective cover date,  $R$  is the number of days beyond effective cover (Duke, 1991).

The  $R$  coefficient is calculated from the  $DOY$  as follow:

$$\begin{aligned}
R(t) &= 0 \quad \text{if } (DOY)_t \leq (DOY)_{plant} \\
R(t) &= \frac{(DOY)_t - (DOY)_{plant}}{(DOY)_{cover} - (DOY)_{plant}} && \text{Eq. 6} \\
&\text{if } (DOY)_{plant} < (DOY)_t \leq (DOY)_{cover} \\
R(t) &= (DOY)_t - (DOY)_{cover} \quad \text{if } (DOY)_{cover} < (DOY)_t \leq (DOY)_{harvest} \\
R(t) &= 0 \quad \text{if } (DOY)_t > (DOY)_{harvest}
\end{aligned}$$

**Table 2.2 Constants for the crop coefficient equation  $K_c = AR^3 + BR^2 + CR + D$**

BEFORE FULL COVER -- R is fraction of time from planting to full cover

<b>Crop</b>	<b>A</b>	<b>B</b>	<b>C</b>	<b>D</b>
<b>Alfalfa</b>	0	0	1.087	0.25
<b>Corn</b>	-1.5830	2.7560	-0.4276	0.2130
<b>Dry Beans</b>	-1.3530	2.5620	-0.3532	0.2120
<b>Pasture</b>	0.0	0.0	1.5080	0.2150
<b>Potatoes</b>	-1.3810	2.4560	-0.3710	0.2130
<b>Sorghum</b>	-1.5830	2.7560	-0.4276	0.2130
<b>Soybeans</b>	-1.3530	2.5620	-0.3532	0.2120
<b>Small Grains</b>	-2.8930	4.8430	-1.1400	0.2330
<b>Sugar Beets</b>	0.1340	0.8782	-0.1899	0.2098

AFTER FULL COVER -- R is days after full cover

<b>Crop</b>	<b>A</b>	<b>B</b>	<b>C</b>	<b>D</b>
<b>Alfalfa</b>	0.0	0.0	2.500E-02	5.000E-01
<b>Corn</b>	2.750E-06	-4.688E-04	1.195E-02	9.150E-01
<b>Dry Beans</b>	1.650E-06	-2.644E-04	-1.120E-04	1.050
<b>Pasture</b>	0.0	0.0	0.0	8.700E-01
<b>Potatoes</b>	0.0	0.0	0.0	9.000E-01
<b>Sorghum</b>	2.750E-06	-4.688E-04	1.195E-02	9.150E-01
<b>Soybeans</b>	1.290E-06	-1.559E-09	-1.551E-04	1.080
<b>Small Grains</b>	4.440E-06	-7.261E-04	8.532E-03	1.02
<b>Sugar Beets</b>	6.255E-07	-1.308E-04	3.426E-03	9.907E-01

*Source: From Duke, H. R. 1991, Scheduling Irrigations*

The actual crop rooting depth  $R_d$  (expressed in (m)) on day (t) is assumed to extend linearly from a planting depth  $R_d$  (min) to a maximum depth  $R_d$  (max) at full cover. It is calculated for the day of the year (DOY) as follows:

$$Rd(t) = 0 \quad \text{if } (DOY)_t \leq (DOY)_{plant}$$

$$Rd(t) = Rd_{min} + \left[ (Rd_{max} - Rd_{min}) * \left[ \frac{(DOY)_t - (DOY)_{plant}}{(DOY)_{cover} - (DOY)_{plant}} \right] \right] \quad \text{Eq. 7}$$

$$\text{if } (DOY)_{plant} \leq (DOY)_t < (DOY)_{cover}$$

$$Rd(t) = Rd_{(max)} \quad \text{if } (DOY)_{cover} \leq (DOY)_t \leq (DOY)_{harvest}$$

$$Rd(t) = 0 \quad \text{if } (DOY)_t > (DOY)_{harvest}$$

Values for  $Rd_{(min)}$  and  $Rd_{(max)}$  are contained in default tables in the program (table 2.3), for each crop-type. If not specified by the user these values are automatically inherited from these tables and assigned to the specific crop. Rooting depth calculations are then performed. An example of this root growth model is shown in figure 2.3.

The basal crop coefficient is modified to account for limited soil water and surface evaporation. The dry soil correction coefficient,  $K_s$  (moisture stress coefficient), represent the plant's reduced ability to extract water from the soil as the matric potential increases, it accounts for the reduction in crop-water use from increased soil water depletion.

This factor is calculated as follows:

$$K_s = 1 \quad \text{if } (DOY)_t < (DOY)_{plant} \quad (\text{Buchleiter et al., 1988})$$

$$(k_s)_t = \ln \frac{\left[ 1 + \left[ 1 - \frac{D_{t-1}}{WHC_{t-1}} \right] * 100 \right]}{\ln 101} \quad \text{Eq. 8}$$

$$\text{If } (DOY)_{plant} < (DOY)_t \leq (DOY)_{harvest}$$

$$\text{Where: } WHC = FC - WP \quad FC = \text{Field capacity} \quad WP = \text{wilting point}$$

$$K_s = 1 \quad \text{if } (DOY)_t > (DOY)_{harvest}$$

**Table 2.3 Rooting depth for selected irrigated crops in Colorado**

Crop	Unrestricted Rooting Depth (m)
Alfalfa	1.2-1.8
Corn	0.15-1.2
Dry Beans	0.15-0.9
Pasture	0.9-1.2
Potatoes	0.15-0.9
Sorghum	0.15-1.2
Soybeans	0.15-0.9
Small Grains	0.15-1.2

Source: Adapted from Duke, H. R. 1991, *Scheduling Irrigations*

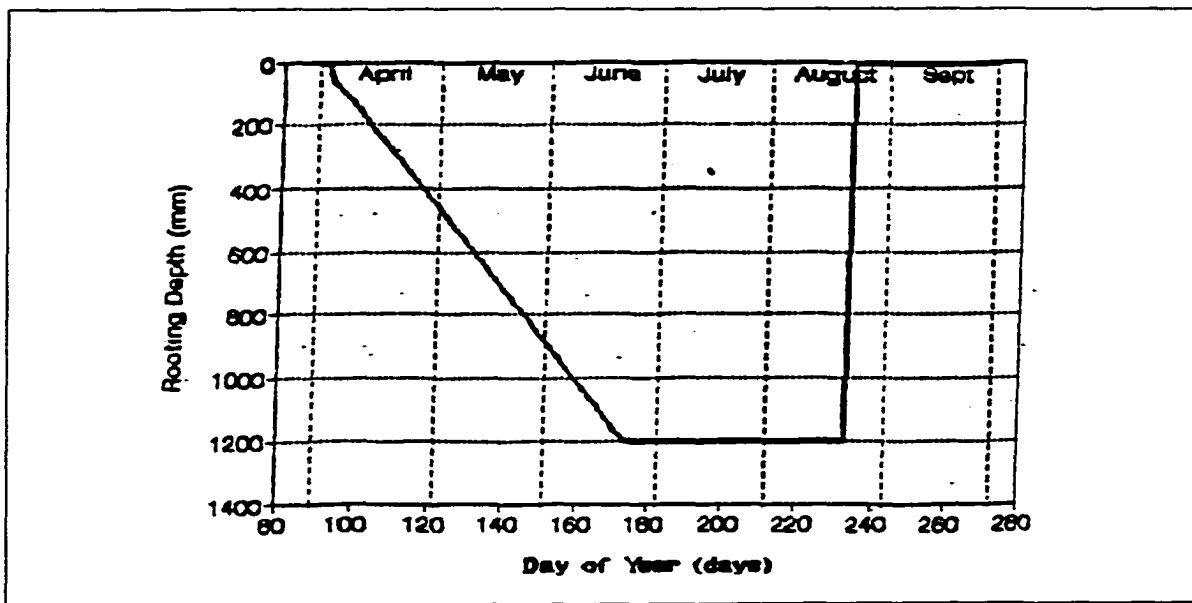

**Figure 2.3 Root growth model**

Source: Jensen, Burman and Allen, 1990, *Evapotranspiration and Irrigation Water Requirements*

The crop coefficient  $K_c$  is then calculated by multiplying the basal crop coefficient  $K_{cb}$  by the dry soil correction coefficient  $K_s$ .

$$K_c = K_{cb} * K_s \text{_____ Eq. 9}$$

Although guides for estimating effective cover are given in the program documentation, local experience should be used whenever possible to estimate when effective cover will occur, usually when maximum vegetation is reached and at 80-90% ground cover. While these dates are easily recognizable to the farmer or scheduling personnel, the simplicity of this approach can cause problems if the growing season is extremely unusual. Unusually cool weather after planting may slow crop development, or unusually late planting may speed crop development, making it necessary to adjust the apparent planting and effective cover dates to match the computed with the actual  $E_t$  rate.

The surface evaporation  $E_w$  is calculated using the wet soil correction coefficient  $K_r$ . It compensates for the additional surface evaporation that occurs immediately following a wetting of the soil surface. Increased surface evaporation from wet soils can be significant early in the season when the plant has an undeveloped canopy. This additional water use  $E_w$  is calculated as follow:

$$E_w = K_r * (0.9 - K_c) * E_{tref} \text{_____ Eq. 10}$$

Where  $K_r$  = wet soil correction factor

$$E_w = 0 \text{ if } K_c \geq 0.9$$

Where  $K_c$  = crop coefficient

$X_d$  = number of days since the irrigation/rainfall event has occurred

if  $K_c < 0.9$  and  $X_d > 1$

$$E_w = K_r * (0.9 - K_c) * E_{tref}$$

if  $X_d = 1$

$$K_r = 0.8$$

and

$$E_w = 0.8 * (0.9 - K_c) * E_{tref} \quad \text{Eq. 11}$$

If  $X_d > 1$

$$K_r = \frac{1}{(4.05 - 15 * WHC)^{X_d - 1}} \quad \text{Eq. 12}$$

if  $X_d > 10$

$$K_r = 0 \text{ and } E_w = 0$$

The actual crop evapotranspiration  $E_a$  in m/day is determined by multiplying the reference evapotranspiration by the crop coefficient based on the stage of growth,  $K_{cb}$  and the available water in the root zone,  $K_s$ , and adding the component of the evaporation from a wet soil surface ( $E_w$ ) calculated above.

$$E_a = (K_c * E_{tref}) + E_w \quad \text{Eq. 13}$$

The actual crop coefficient and the basal crop coefficient are shown in figure 2.4. The actual crop coefficient spikes above the basal crop coefficient when evaporation occurs after wetting events. The spike lasts only for a couple of days until the soil surface dries out. It is most significant early in the season while the crop canopy is developing. The actual crop coefficient is below the basal crop coefficient when the soil-water depletion increases and the plant is unable to readily extract water from the soil as the matric potential increases. Plants are not passive to water stress. They will attempt to regulate their consumptive use of water by decreasing turgor pressure and constricting stomata openings when the soil becomes dry.

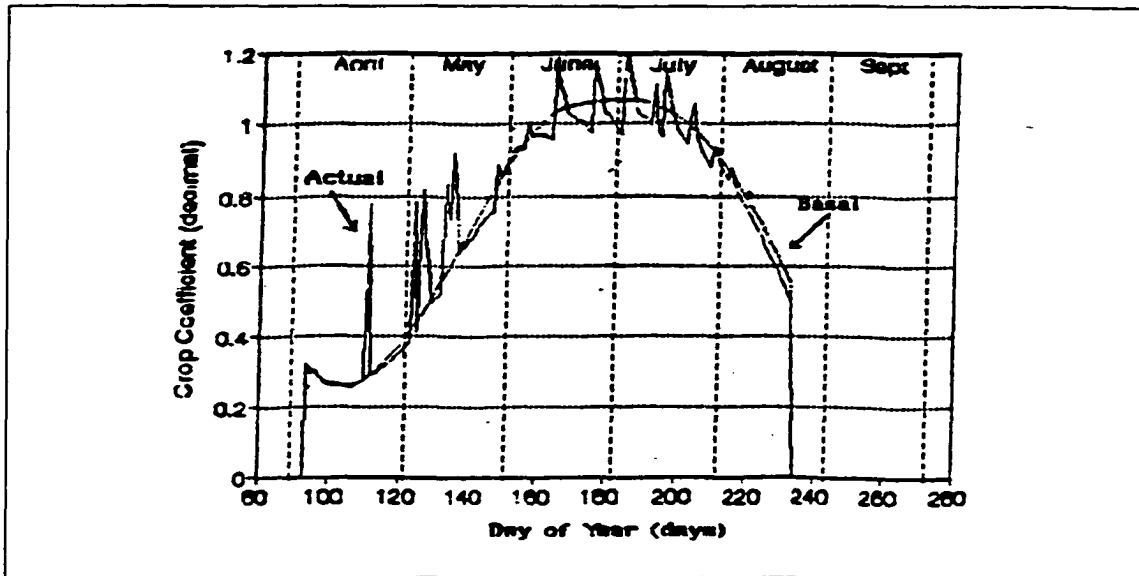

**Figure 2.4 Crop coefficient curves**

*Source: Jensen, Burman and Allen, 1990, Evaporation and Irrigation Water Requirements.*

The effective irrigation  $I_e$  in meters is the amount of water from an actual irrigation application ( $I_{gross}$ ) that enters the soil profile. The effective irrigation amount ( $I_e$ ) is the product of the gross irrigation times application efficiency  $E_a$  expressed as a percent:

$$I_e(t) = I_{gross}(t) * \left( \frac{E_a}{100} \right) \quad \text{Eq. 14}$$

Application efficiency values are inherited by the program from default databases as function of the irrigation system type spatially presented in the area. It is somewhat different from the usual definition of application efficiency, i.e., the amount of water stored in the root zone divided by the gross amount of water applied. The difference between the two definitions is the inclusion of the deep percolation as water entering the soil profile but not stored in the root zone. Deep percolation is not included implicitly as an efficiency loss in the definition used here because the model calculates the amount of

percolation explicitly. All water entering the soil profile is available for plant use until it percolates below the root zone. The two definitions are equivalent when water does not percolate below the root.

When the soil water content is above field capacity, the excess water will drain. The percolation (DP) is calculated as the drained water moving downward through the soil profile. A variable taken into consideration on the calculation of the deep percolation is the transient water ( $D_{\text{TRANSIENT}}$ ), which is defined as the amount of water that while moving downwards the soil water profile, and through the root zone is used by the crop. An empirical equation is used to calculate the fraction of transient water available in the root zone. It is subtracted from the depletion and is dependent on soil type. For sandy soils, the time of drainage is about one to two days whereas for clay soils it may be four to five days. The fraction of water available in the root zone, F is calculated as:

$$F = \frac{1}{4.05 - (15 * WHC)^{X_d}} \quad \text{Eq. 15}$$

Where:

WHC = water holding capacity of the soil in m/m

and  $0 < F < 1$

When  $X_d = 1$ ,  $F = 0.9$

Where:  $X_d$  = number of days since the precipitation/irrigation event has occurred

If  $F > 1$  then  $F = 1$

The portion of the transient water that is not used to satisfy  $E_t$  and leaves the root zone each day is considered percolation.

The available water holding capacity (WHC) expressed as a depth in (m) represents the amount of plant available water the soil is able to hold.

It is defined as:

$$D_{whc} = WHC * Rd(t) \text{-----Eq. 16}$$

where: WHC = FC - WP      FC = field capacity      WP = wilting point

The management allowable depletion expressed, as a depth  $D_{mad}$  in meters is determined from the allowable depletion expressed as a fraction of the available water holding capacity, " $f_{mad}$ ". Values for " $f_{mad}$ " are stored in default tables inside the program as a function of the crop-type and growing stage. The user can manually enter values, if not they are automatically inherited by the program from default databases.

$$D_{mad} = D_{whc} \quad \text{if } (DOY)_t < (DOY)_{plant}$$

$$D_{mad} = f_{mad} * D_{whc} \quad \text{if } (DOY)_{plant} \leq (DOY)_t \leq (DOY)_{harvest} \text{-----Eq. 17}$$

$$D_{mad} = D_{whc} \quad \text{if } (DOY)_t > (DOY)_{harvest}$$

The current soil water deficit (depletion) expressed as a depth " $D_d$ " in (m) within the layers of soil represented by the current rooting depth is calculated from the soil water mass balance. Assuming that before planting the soil is at field capacity then:

$$D_d(t) = 0 \quad \text{if } (DOY)_t < (DOY)_{plant}$$

and

$$D_d(t) = D_d(t-1) + Eta(t) + Ew(t) - Ie(t) - Rt + P(t) \text{-----Eq. 18}$$

$$\text{if } (DOY)_{plant} < (DOY)_t < (DOY)_{harvest}$$

The recommended amount of irrigation water needed to refill the profile on the following day ( $I_{gross}$ ) (m) is calculated based upon timing status of the irrigation and deficits.

$$(I_{gross})_{(t+1)} = \frac{D_d(t)}{\frac{Ea}{100}} \quad \text{Eq. 19}$$

No reservoir is left for expected precipitation. Thus, if precipitation occurs immediately after irrigation the soil moisture will exceed field capacity and percolation will likely result.

## **2.3 Program Data Requirements**

The information required by the program has been organized into categories based on an association with a location or a field. All of the information needed to run the program is listed below in section 2.3.1, 2.3.2 and 2.3.3.

### **2.3.1. Location Information**

Location information consists of data that identifies and characterizes a region where evapotranspiration is being calculated. It includes daily meteorological information, which must be entered for each day of the growing season. Reference evapotranspiration and precipitation is included in this information and must be entered for each day of the

growing season. If precipitation is not entered for a particular day, it is assumed to be zero.

### 2.3.2. Field Information

Field information consists of data that identify and characterize a field where a crop is grown. This information is used to calculate the soil water content and schedule the irrigation. The field information is made up of soil information, irrigation system information, crop information and daily scheduling data.

#### Soil Data

Soil data identifies and characterizes the soil type. The soil information consists of the soil name, that soil type, the field capacity soil water content, the permanent wilting point soil water content. The soil water content at field capacity is defined as the water a soil can hold after it gravity drains from saturation. It is often approximated by the laboratory determined soil water content at 1/3 bar of matric potential.

The permanent wilting point is the lower limit of the crop extractable water. A crop is unable to extract water below that soil water content. If a crop is stressed to this point, death will occur. The permanent wilting point is actually a function of the crop as well as the soil type. However, this parameter is usually treated as a function of soil type and is approximated by the soil water content remaining at 15 bars of matric potential. The available water holding capacity is the difference between field capacity and permanent wilting point. It can be calculated from the other two soil water contents and is an optional

piece of information, but can be specified if desired (see table 2.4). The user can either enter that information or not. If not entered by the user these values are automatically inherited by the program from default databases, function of soil type and geographic location.

**Table 2.4 Soil database**

<b>Default Soil Database</b>			
<b>Texture Type</b>	<b>Field Capacity (m/m)</b>	<b>Permanent Wilting Point (m/m)</b>	<b>Available Water Holding Capacity (m/m)</b>
<b>Clay</b>	0.41	0.28	0.13
<b>Clay Loam</b>	0.38	0.21	0.17
<b>Loam</b>	0.34	0.13	0.21
<b>Loamy Sand</b>	0.19	0.07	0.12
<b>Sand</b>	0.14	0.06	0.08
<b>Sandy Clay</b>	0.40	0.25	0.15
<b>Sandy Clay Loam</b>	0.38	0.19	0.19
<b>Sandy Loam</b>	0.24	0.09	0.15
<b>Silt</b>	0.39	0.16	0.23
<b>Silt Clay</b>	0.40	0.25	0.15
<b>Silty Clay Loam</b>	0.40	0.18	0.22
<b>Silty Loam</b>	0.38	0.15	0.23

*Source: Values Adapted from Duke, H. R. 1991, Scheduling Irrigations*

### **Irrigation System information**

Irrigation system information consists of data that identify and characterize the field's irrigation system. This includes the irrigation system type and application efficiency.

Irrigation efficiency is the most commonly used term to describe how well water is being used (Molden and Sakthivadivel, 1999). The efficiency is defined as the amount of irrigation water that will effectively infiltrate the soil surface and enter the soil profile where it becomes available for plant consumptive use. Table 2.5 shows application efficiencies associated with each irrigation system. In absence of better information those values can be used.

**Table 2.5 Irrigation application efficiencies**

<b>Irrigation Application Efficiencies</b>		
<b>Irrigation System</b>	<b>Application Efficiency E%</b>	<b>Comments</b>
<b>Drip</b>	75-100	High Percolation Loss if Spaced too far apart. Average 90%
<b>Sprinkler</b>	70-90	< 70% if operated at wind speeds exceeding 6-10mph, if runoff occurs or low pressure operated on steep terrain. Average 85%
<b>Level- Basin</b>	70-90	
<b>Furrow-Sandy</b> <b>Furrow - Clay</b>	20-60 50-90	Increased by tailwater reuse, reduced furrow length, improved management methods such as surge, cablegation. Decrease by neglect maintenance, improper leveling, and poor irrigation management. Average varies greatly since soil variability is a greater factor for above systems.
<b>Lateral -Move</b>	90	
<b>Surge - Sandy</b> <b>Surge - Clay</b>	30-70 60-90	

*Source: Adapted from Duke, H. R. 1991, Scheduling Irrigations*

### **Crop Information**

Crop information consists of data that identify and characterize a field crop. This information consists of data specific to the crop and data specific to the crop growth stage.

Information specific to the crop includes the crop name, planting depth, maximum and minimum rooting depth, dates of plant and harvest, the crop coefficients before and after full cover and four crops growing stages:

1 = vegetative

2 = flowering

3 = yield formation

4 = harvest

The basal crop coefficient is defined in terms of two third order polynomials as described earlier. The first Polynomial indicates the crop coefficient from planting to full cover (stage of grow number 3, yield formation). The second polynomial indicates the crop coefficient from full cover to harvest. The crop information specific to each growth stage specifies the duration of that growth stage and defines the management allowable depletion during that growth stage. A management flag associates certain management events that the program recognizes with a particular growth stage. Recognized management events include the four growing periods.

The  $f_{\text{mad}}$  variable defines the critical soil water content as a fraction of the WHC. The critical point soil water content specifies the management allowable depletion. To avoid

crop yield reduction, the field is to be managed so that the soil water content is kept above this critical soil water content. The  $f_{mad}$  variable can vary between zero and one.

A  $f_{mad}$  value of zero indicates that the critical point soil water content equals field capacity. If this value was specified, the model would recommend irrigating whenever the current soil water content fell below field capacity. A  $f_{mad}$  value of one indicates that the critical point soil water content equal the permanent wilting point. If this value were specified, the model wouldn't recommend irrigating until plant death occurred. Reasonable values for  $f_{mad}$  lie somewhere between these two extremes.

Values for  $f_{mad}$  are stored inside the program in a database. It varies for different crop types and growing period. The user has a choice of entering those values manually. If not they are automatically inherited from the default databases function of crop-type and growing stage as shown in table 2.6.

### **Field Management Information**

The field management information consists of the planting date, the effective cover date, the harvest date, the initial soil water content and the initial date. The initial soil water content refers to the field's soil moisture at an initial date sometimes before the crop is planted. This value is used to initialize the soil water content. The program has stored values of field capacity for different soil-types. When the initial soil water content is not manually entered, the program assumes that the soil is at field capacity, that is, the soil water reservoir is filled with water.

Once the plant date is entered, the program automatically calculates values for effective cover date and harvesting dates. If the user wants to manually enter a date for effective cover and harvesting he can do so.

**Table 2.6 Suggested maximum allowable depletions for different stages of grow**

<b>Maximum Management Allowable Depletion for different Crops at different stages of grow</b>				
<b>Crop</b>	<b>Period # 1 vegetative</b>	<b>Period # 2 Flowering</b>	<b>Period # 3 Yield Formation</b>	<b>Period # 4 Harvest</b>
<b>Alfalfa</b>	0.5	0.5	0.5	0.5
<b>Beans</b>	0.7	0.4	0.5	0.8
<b>Corn</b>	0.8	0.4	0.4	0.8
<b>Pasture</b>	0.5	0.5	0.5	0.5
<b>Potatoes</b>	0.8	0.5	0.4	0.7
<b>Small Grains</b>	0.7	0.5	0.5	0.6
<b>Sorghum</b>	0.8	0.4	0.5	0.8
<b>Soybeans</b>	0.7	0.4	0.5	0.8
<b>Sugar Beets</b>	0.7	0.7	0.7	0.8
<b>Wheat</b>	0.7	0.5	0.5	0.6

*Source: Adapted from Duke, H. R. 1991, Scheduling Irrigation*

### 2.3.3 Geographic Databases

To aid the data entry process, a set of databases has been incorporated into the model. A soil database, climatic database, crop database, an irrigation system database, a growing

period database and a crop water allocation priority database. When a location or a field is created, the location information or the field information above is required. This information should be appropriate to your particular site for the model to accurately represent your situation. The required information can be inherited from this database or entered manually if desired. This allows the model to run even when the user does not know some of the required parameters. However it should be taken into consideration that reliance on general databases will result in reduced reliability of the results.

Each database can be altered and customized from within the program. This allows the user to edit, add or delete appropriate elements of a database so that it more accurately represents the user's requirements. For example an agricultural manager can add crops to the crop's database and the information pertained to that crop. Information pertaining to a crop could be inferred from the database as opposed to entered by hand. Similarly a crop consultant within a given farm could customize the soil's database to represent the spectrum of soil type found within that farm.

The default database contains the average soil water characteristics for each soil texture. Associated with each soil is a soil series name, the texture, the soil water content at field capacity, the soil water content at permanent wilting point and the available water holding capacity at different soil depths.

The default crop database contains information for different crop types. Associated with each crop type is a crop name, minimum rooting depth, maximum rooting depth, crop coefficients A, B, C, D before and after full cover, which are to be used in the third order polynomial equation mentioned earlier, length of each of the four growing periods,

vegetative, flowering, yield formation and harvest, values for  $f_{mad}$  associated with each crop type and growing period, date-plant and date-harvest.

The climatic database contains information on a station name, location, reference evapotranspiration, and precipitation during the season. When a farm designated within the location is represented by more than one weather station or a data collection point the Thiessen polygon's theory can be used to apportion the point coverage into regions known as Thiessen or Voronoi polygons, (see item 2.1.3 for description of the Thiessen Polygon Theory).

The default irrigation system database contains the irrigation system and the application efficiencies associated with each irrigation system. In absence of better information, default efficiency can be used.

## **CHAPTER 3**

### **WATER ALLOCATION**

#### **3.1 An Overview of the On-Farm Water Allocation Model**

##### **3.1.1 Model Objective**

Water needs of the crop are of paramount importance in determining the allocation and time of irrigation during the crop-growing season on irrigation projects that have limited water supply.

The purpose of the water allocation model is to allocate the water without compromising the yield for the different crop species during the entire growing season even when water is limited temporarily to some fields.

Growing crops use water continuously, but the rate of use varies with the kind of crop grown, root depth, stages of grow, crop sensitivity to water stress, crop yield, field capacity (storage capacity), available water and atmospheric conditions. The water allocation model determines which fields are to be irrigated in order of priority to achieve a yield goal.

## **NOTE TO USERS**

**Page(s) not included in the original manuscript and are unavailable from the author or university. The manuscript was microfilmed as received.**

**61**

**This reproduction is the best copy available.**

**UMI<sup>®</sup>**

and changed if needed, so that the database can be customized, as better information becomes available.

Although the water allocation model was designed as an independent, stand-alone model, it was developed as a part of an integrated system with the irrigation scheduler. As an integrated system the water allocation model is called immediately after the execution of the irrigation scheduler. The irrigation scheduler saves, passes the field's water requirements via a file data to the water allocation model. The water allocation model then evaluates the field-crop-water data and determines the water allocation priority for each field crop.

Most of the information needed to run the water allocation model is obtained from the irrigation scheduler. The main variables included in the model are crop grown, stage of growth, root depth, crop yield response factors, field capacity and management allowable depletion. The model evaluates these variables, performs its analysis, establishes priorities throughout the growing season and displays the results to the user in map form. Water is a constraint to production and can reduce yield if not applied at the proper time and quantity. The farmer's capability to deliver water includes variable amount and variable timing. Flexibility to manipulate the rate and duration of flows in the course of the irrigation can ensure uniformity of application across the field (Cross, 2000).

The allocation module checks for the quantity of water available for irrigation and the quantity of water needed for the fields to be irrigated. It then assigns fields to be irrigated based upon priority. The fields that are left without irrigation will automatically be transferred to the next day. The user has the option of specifying any field to be irrigated

at any given day before or after the requested schedule or not be irrigated in any given day due to management constraints.

The program calculates the head-loss throughout the pipe system and valves, and the head necessary to irrigate. This is checked against the head-available. There may be enough water to irrigate all the fields on a given day but not sufficient head to supply the flow rate. The model also calculates irrigation time based on the depth of irrigation needed and the infiltration rate of the soil. Further, it accounts for the available water for irrigation, the quantity of water used and the hours of operation of each well and surface diversion to refill the reservoir.

## **3.2 Variables Included in the Model**

### **3.2.1 Crop Type and Grow Stage Affect Water Allocation Priority**

During the growing season different crops demand different quantities of water. Most crops grow best under irrigation with moderate quantities of soil water and production is decreased by either excessive or deficient amounts. Air in the soil is essential to satisfactory crop growth. Thus, saturating the soil with water inhibits proper functioning of the plants. On the other hand, soils having deficient amounts of water cannot be used effectively by plants. If the rate of intake by the plant is not high enough to maintain turgidity of the leaves, permanent wilting follows. At some soil water content between these two extremes moisture conditions, i.e., field capacity and permanent wilting point, an optimum moisture percentage exists, at which plants grow most rapidly.

Seasonal use of water by different crops should not be retarded by lack of available soil moisture. Irrigation farmers must select their crops, to some extent, on the basis of time at which water would be available to them. During the crop-growing season, different crops demand different quantities of water.

Stage of growth for crops can be divided into four categories with regard to irrigation practice. Vegetative, Flowering, Yield formation and Harvest. The first three stages are related to consumptive water use as illustrated in figure 3.1. During the vegetative stage consumptive use continues to increase. Flowering occurs near and during the peak of consumptive use. The yield formation stage is accompanied by a decrease in consumptive use until the transpiration essentially ceases at harvest.

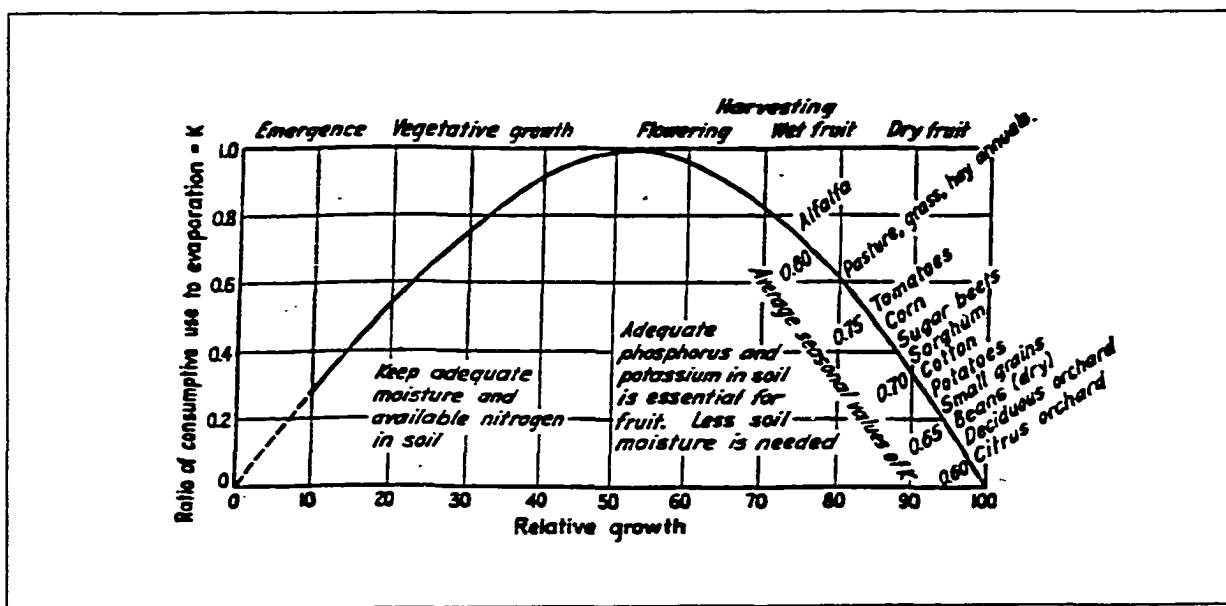

**Figure 3.1 Generalized curve comparing consumptive use-evaporation ratio to relative growth of crop**

Source: Israelsen, *Irrigation Principles and Practices*, 1979

The amount of irrigation water allocated must be adjusted to the actual consumptive use of the crop, water holding capacity of the soil and rooting depth. Naturally, a shallow sandy soil will require quite different scheduling of irrigation than will be required for a deep clay loam soil.

Alfalfa, wheat and oats require large amounts of water during early stages of growth (vegetative). Sugar-beets, potatoes and corn are among the crops that require less water early in the season, but late in the season, i.e., yield formation; these crops will need an abundance of water, (Israelsen, Irrigation Principles and Practices, 1979). Unless late season water is assured, it is inadvisable to attempt to grow sugar-beets and potatoes because it would cause crop stress and yield reduction.

### 3.2.2 Soil Moisture Removal and Depth of Crop Root Zones

When to irrigate and how much to apply are affected considerably by where and when water is removed from the soil by plant roots. Shallow rooted-crops will require more frequent irrigation than deep-rooted crops. This is caused by two factors, the depth to which the applied water penetrates and the moisture content of the soil during the growing period. More water is extracted from the first foot of soil whenever the first foot is kept moister either by frequent rains or irrigation, (Israelsen, Principles and Practices, 1979).

Assuming a favorable unrestricted root zone, the depth of rooting increases during the vegetative and flowering period as mentioned earlier and remains constant after yield formation until harvest.

### *3.2.3 Crop Type and Sensitivity to Water Stress*

A good moisture supply normally should be available to plants at all stages of growth. When water is limited during an irrigation day, crops with higher sensitivity to water stress during that specific grow stage should be given irrigation priority to prevent yield reduction. Table 3.1 shows growth period which crops are most sensitive to water stress.

#### *Water Allocation During the Vegetative Period of Growth*

Alfalfa and oats are examples of crops sensitive to water stress at this period requiring large amount of water. So water allocation priority should be given for those crops at this growing period, (Israelsen, Irrigation Principles and Practices, 1979)

#### *Water Allocation During the Flowering Stage of Growth*

Since consumptive use is at or near a maximum during the flowering stage for most crops, care must be exercised to ensure adequate moisture in the root zone. Furthermore, in many growing climates the climatic potential  $E$  increases due to the top growth becoming larger (LAI-Leaf area index, i.e. area of one side of all leaves divided by ground surface, Stegman et al. 1976), thus increasing transpiration. This happens because although the excessive presence of vegetation retards evaporation from the soil surface (by increasing shade and humidity and reducing wind near the surface) the difference is probably compensated or even exceeded by increased leaf transpiration (Bernatowicz et al. 1976). When this difference is exceeded there is an increase in potential evapotranspiration rate and consequently in crop water requirements.

**Table 3.1 Growth period during which crops are more sensitive to water stress**

<b>Crop</b>	<b>Most Sensitive Stages</b>
<b>Alfalfa</b>	Just after cutting (and for seed production at flowering)
<b>Beans</b>	Flowering and pod filling; vegetative period not sensitive when followed by ample water supply
<b>Cabbage</b>	During head enlargement and ripening
<b>Carrots</b>	Sensitive during entire season, especially from seeding to emergence
<b>Corn</b>	Tasseling more sensitive than grain filling; tasseling very sensitive if no prior water deficit
<b>Cucumbers</b>	Fruit production more sensitive than flowering, which is more sensitive than vegetative period
<b>Grapes</b>	Vegetative period, particularly shoot elongation and flowering more sensitive than fruit fill
<b>Lettuce</b>	Sensitive during entire season, especially from seeding to emergence
<b>Onions</b>	Bulb enlargement, particularly during rapid bulb growth more sensitive than during vegetative period (flowering sensitive period for onions grown for seed)
<b>Peas</b>	Flowering and Pod fill greater than vegetative or ripening for dry peas
<b>Pepper</b>	Throughout particularly just before and early flowering
<b>Potatoes</b>	Stolonization and tuber initiation, tuber enlargement greater than early vegetative period and ripening
<b>Sorghum</b>	Heading to soft dough greater than vegetative; vegetative period less sensitive when followed by ample water
<b>Soybeans</b>	Flowering and particularly during pod filling
<b>Squash</b>	Fruit production more sensitive than flowering, more sensitive than vegetative period
<b>Sugar-Beets</b>	First month after emergence
<b>Sunflowers</b>	Flowering greater than seed fill, both greater than vegetative. Particularly sensitive during period of bud development
<b>Sweet Corn</b>	Early formation stage most sensitive, keep well watered from pollination to harvest
<b>Tomatoes</b>	Flowering greater than fruit fill. Least sensitive during vegetative, except transplant period
<b>Watermelon</b>	Flowering, melon enlargement greater than vegetative period, particularly during vine development
<b>Wheat</b>	Heading to soft dough greater than vegetative period; winter wheat less sensitive than spring wheat

*Source: From Duke 1991, Scheduling Irrigations*

Deeper roots have a greater root zone depth and hence a larger potential water supply available. Best production is obtained if the crop is kept adequately irrigated during both vegetative and flowering stages. Green peas, sugar beets and grains are examples of crops sensitive to water stress at this stage of growth.

### **Water Allocation During the Yield Formation Stage of Growth**

The root system is essentially extended to its maximum depth by this stage of growth and consumptive use has begun to decrease reducing crop water requirements. The water requirements of the crop are usually met from water stored in the soil. Deep-rooted crops will most probably have water available during this final stage of development. Tubers like potatoes and peanuts require adequate moisture during the entire growth period. Sugar beets and onions are very sensitive to water stress during this stage of growth

### **3.3 Multi Parameter Approach Criteria**

The steps performed toward achieving the best field-crop-water priority setting were done evaluating a variety of crop-soil parameters. They are, crop type, stages of grow, rooting depth, crop sensitivity to water stress, yield response factor, field capacity and management allowable depletion. Using all those variables and considering the constraints of the irrigation system, a water allocation model was designed to advise a water allocation schedule.

Crop yield is a parameter of paramount importance when setting a priority for allocating water to a specific crop. Under limited availability of irrigation water the relation between relative yield reduction and relative evapotranspiration deficits are very

important in the determination of the field or block to be irrigated in a given day. The relation is given by the empirically derived yield response factor  $K_y$  (Doorenbos and Kassam, 1979) which shows the relationship between plant growth and water use, (see item 1.4 for description of  $K_y$ ). This parameter is used in the water allocation model to allocate irrigation priorities for different crops during different stages of growth.

The  $K_y$ -values are based on experimental field data covering a wide range of growing conditions and represent the response of crop varieties well adapted to the growing environment and grown under a high level of crop management. For some crops there are evidence that water stress in an early growth stage may diminish the effect of water stress in a more advanced and sensitive growth stage. This is called conditioning due to plant physiological and root development factors. A yield response factor ( $K_y$ ) table has been prepared by the FAO and is shown in table 1.1, chapter 1.

Knowledge of  $K_y$ -factors in conjunction with individual crop type, growth stages, management allowable depletion and root depth is used in this research to allocate a limited supply of irrigation water toward meeting the full water requirements of the crop during their most sensitive growth stages.

Generally higher  $K_y$  values indicate that the crop have a greater yield loss when crop-water requirements are not met (Doorenbos and Kassam 1986). So, in allocating irrigation water, crops with higher values of  $K_y$  are given irrigation priority. When water stress occurs, crop growth and yield formation are affected. The yield reduction as result of water stress depends on the type of crop grown on one hand and on the magnitude and duration of occurrence of the water stress on the other. Not only crop species vary in their response to water deficits, but also each crop reacts differently to water deficits in its

individual growth stages. In general crops are more sensitive to water stress during flowering and yield formation than they are during early and late growth.

Considering the crop parameters, crop type, rooting depth, maximum allowable depletion,  $K_y$  and growing period, a matrix was developed and the coefficient  $K_w$  (crop sensitivity to water stress) determined and assigned to each crop type.  $K_w$  varies from one to a hundred and it is an integer number assigned to the crop. Crops with lowest value of  $K_w$  should be irrigated first. This database is internally stored in the program and the irrigation allocation priority for crops are inherited from the database as a function of crop type and growing period (see table 3.2 water allocation order).

**Table 3.2 Water allocation order**

Crop	Period # 1 Vegetative			Period # 2 Flowering			Period # 3 Yield Formation			Period # 4 Harvest		
	$K_y$	$K_w$	Irr	$K_y$	$K_w$	Irr	$K_y$	$K_w$	Irr	$K_y$	$K_w$	Irr
<b>Alfalfa</b>	0.9	1	5	0.0	6	20	0.1	7	20	0	4	20
<b>Beans</b>	0.2	5	17	1.1	2	3	0.75	3	9	0.2	3	17
<b>Corn</b>	0.4	4	15	1.5	1	2	0.5	5	13	0.2	3	18
<b>Pasture</b>	0.1	100	100	0	100	100	0.1	100	100	0	100	100
<b>Potatoes</b>	0.8	2	8	0.6	6	20	0.7	4	10	0.2	3	17
<b>Small – Grain</b>	0.2	5	19	0.65	4	11	0.55	5	12	0	4	20
<b>Sorghum</b>	0.2	5	18	0.55	5	12	0.45	6	14	0.2	3	18
<b>Soybeans</b>	0.2	5	18	0.8	3	7	1	1	4	0	4	20
<b>Sugar – Beets</b>	0.8	2	7	0.8	3	8	0.8	2	8	0.8	1	8
<b>Wheat</b>	0.2	5	19	0.65	4	11	0.55	5	12	0.0	4	20

*Irr* = irrigation allocation priority

Another parameter considered when allocating water to a field is the storage capacity of the soil. The closer this value is to MAD, the more water is needed, and the crop field should be given irrigation priority.

The irrigation scheduler module computes the quantity of irrigation water necessary to be applied to each field. The water allocation module then evaluates the fields to be irrigated at a given day and assigns priority from one to hundred to each field to be irrigated. A map of the farm is then displayed on the screen, the numbers assigned to each field will indicate irrigation order, and full color pattern will indicate the field that needs to be irrigated. Field with number one assigned to it, should be the first to be irrigated and field with number hundred the last. Item 3.9 of this chapter show the results of the GIS-model and water distribution in form of maps and tables.

### **3.4 Allocating the Available Water to Each of the Irrigated Crops**

During the designing process of the water allocation model some conditions and constraints must be established.

They are:

- 1) The irrigations are scheduled to occur Monday to Friday within a ten-hour working day.
- 2) Each field at ARDEC has a single crop. Figure 3.2 shows the lay-out of the crops at ARDEC.
- 3) Soil type can have spatial variability within a field causing variable infiltration rate and soil water holding capacity. Figure 3.3 shows soils distribution at ARDEC.

4) Assurance that the irrigation system is hydraulically able to deliver the scheduled water including the pipe distribution system and available water from the reservoir, surface diversion and wells are adequate.

5) Integration of the irrigation scheduling with farming operations such as tillage, harvest and other cultural operations.

### **3.5 Description of the Irrigation System**

The irrigation system at ARDEC is a very complex system, with water drawn from both surface and well water sources. The system comprises four booster pumps in addition to the three wells. More than 16,000 feet of pipe ranging in size from 6" to 24", 75 hand operated valves, and 50 air relief valves control water deliveries to more than 40 field turnouts. A reservoir allows mixing of well and ditch water. For the flow rate of 1000 gpm from the farthest turnout on the south end, the travel time of water in the pipelines is about 75 minutes. The system provides some amount of flexibility in management of irrigation, but because of the complexity of the system, certain operational rules are mandatory.

Figure 3.4 shows the lay out of the irrigation system at ARDEC and the distribution of the buried pipes. Figure 3.5 shows the lay out of the pipe-system.

For the linear move system the water is supplied through a 121mm flexible hose that is attached to one of the two existing hydrants. Each span is divided into two PVC pipe segments with a diameter of 38mm that are attached to the main lateral.

### 3.5.1 Water Sources at the ARDEC-Farm

ARDEC has five water sources. It has three wells. One situated in the North part, north of county road 56 and the other two situated in the south side of ARDEC, south of county road 56, east and west of the ARDEC farm road, North of field# 100 and North of field# 600. There is one ditch and one reservoir situated North of county road 56. The reservoir is located beside the ditch.

They generate the following discharges:

North Well: 900gpm or 205m<sup>3</sup>/h

South Well: 600 gpm or 135m<sup>3</sup>/h each (southeast and southwest)

Ditch-water: 1100gpm or 250m<sup>3</sup>/h

Reservoir Capacity: 10ac-ft or 12335m<sup>3</sup> or 102 m<sup>3</sup>/h

This database is internally stored in the program. Values are inherited from this database when needed function of the water source required. An assumption was made that all water sources available at ARDEC can be pumped or diverted to the reservoir until it reaches full capacity. Water is pumped from each well and diverted from the ditch to the reservoir until it reaches full capacity. The surface water diversion is delivered in 24 hours increments.

Only 60% of the total water volume of the reservoir can be used for irrigation. The other 40% must remain in the reservoir for fire prevention. The model generates a table indicating the hours of operation of each well and the surface diversion in order to refill the reservoir after each irrigation. Water will be delivered from the reservoir to the fields.

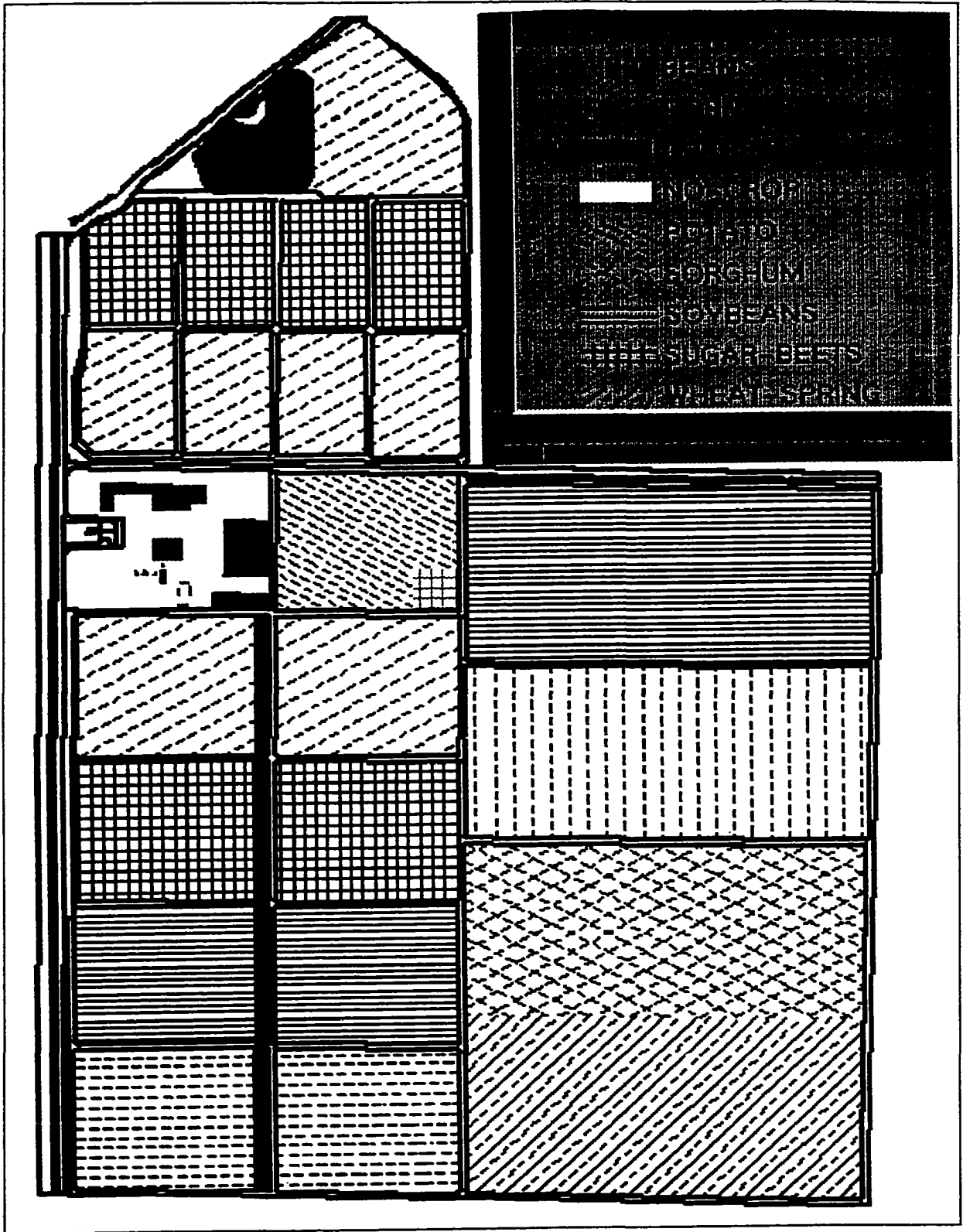

**Figure 3.2 ARDEC - Crop system lay-out**

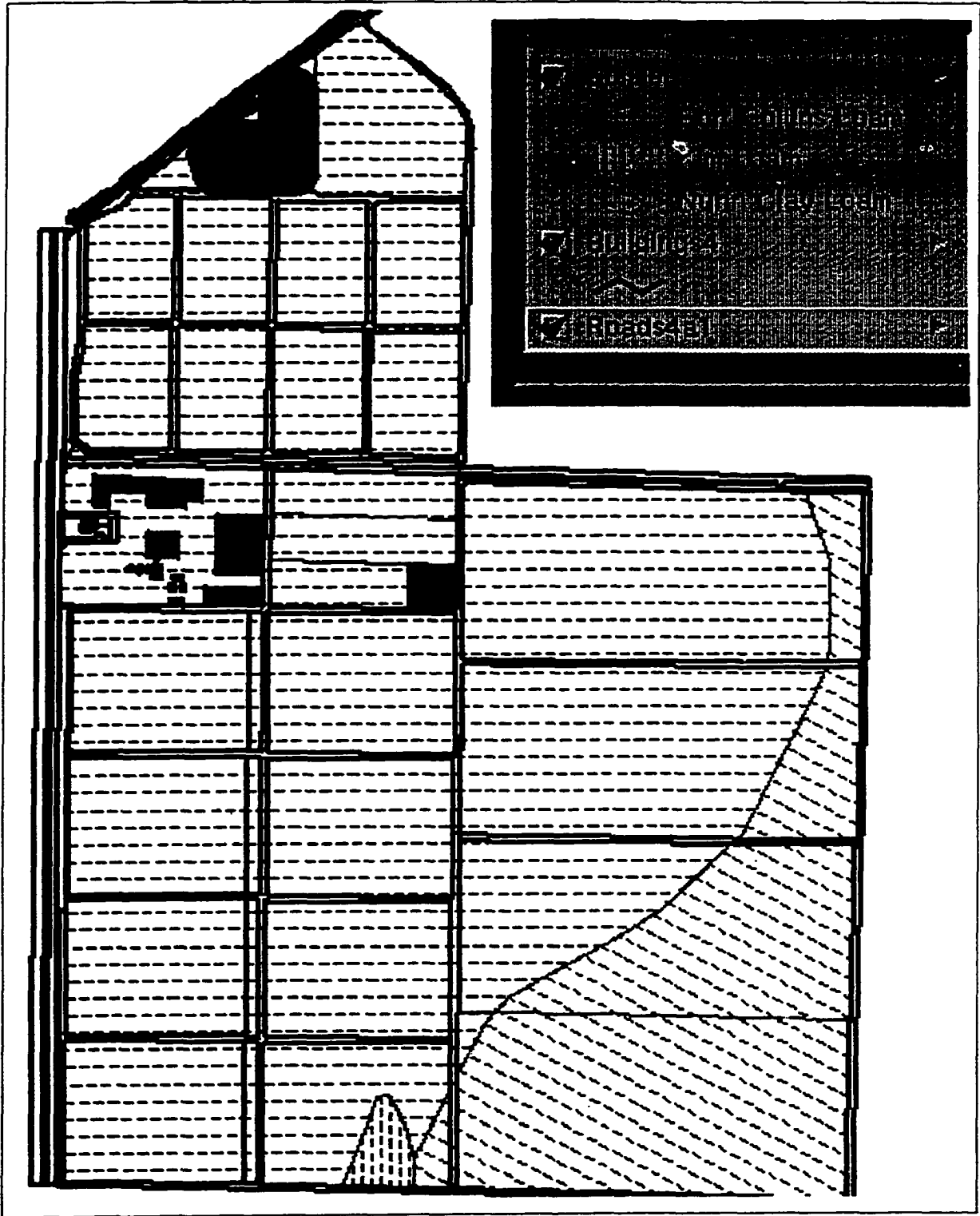

**Figure 3.3 ARDEC - Soil distribution lay out**

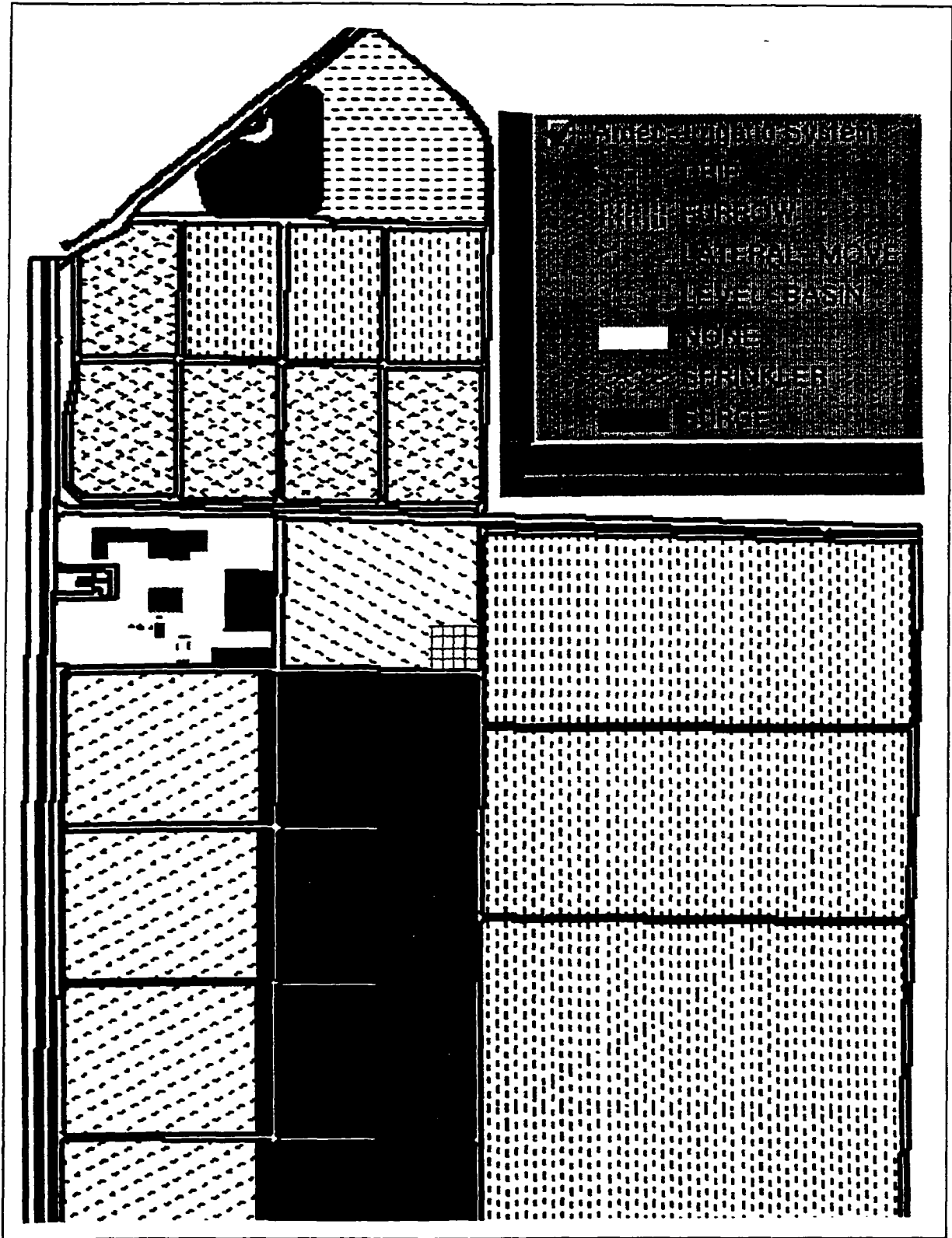

**Figure 3.4 ARDEC - Irrigation system lay-out**

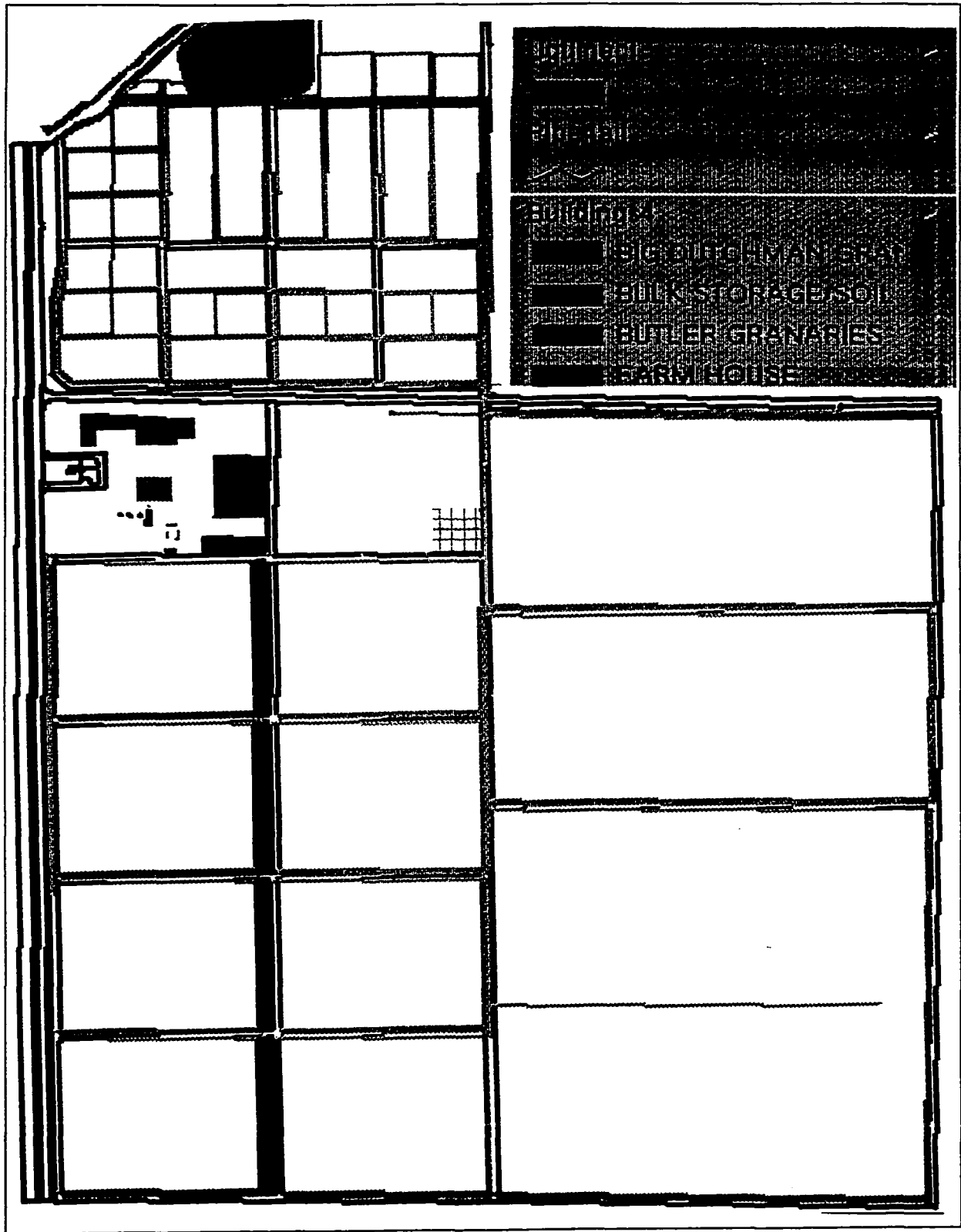

**Figure 3.5 ARDEC - Pipe distribution System lay-out**

### **3.6 Hydraulics of Flow**

Irrigation water is conveyed in either open or closed conduits. At ARDEC only closed conduits convey the water. Hydraulically, the two methods are similar. Differences are usually measured to determine the flow rate. In an open-channel flow the pressure head does not change and the slope of the water surface is the criterion of the flow.

The successful operation of the water distribution network requires care to ensure that the system is hydraulically able to deliver the scheduled water. This will include the pipe distribution system and an accounting of the available water from the reservoir, surface diversion and wells.

To ensure that the system is hydraulically feasible, the friction head-loss in pipelines and valves should be computed, figure 3.6 shows the lay-out of the main pipes and valves at the ARDEC research farm. There are numerous methods for computing friction-head-loss in pipelines. One of the most common and convenient methods applicable to the flow of water through irrigation systems is the Hazen-Williams equation (Jensen, 1980, Design and Operation of Farm Irrigation Systems) given as:

$$H_f = k_1 * L * \frac{\left[ \frac{Q}{C} \right]}{D^{4.87}} \quad \text{Eq. 20}$$

where:

$k_1$  = conversion constant

$L$  = length of pipe, L

$Q$  = volumetric flow rate, L<sup>3</sup>/t

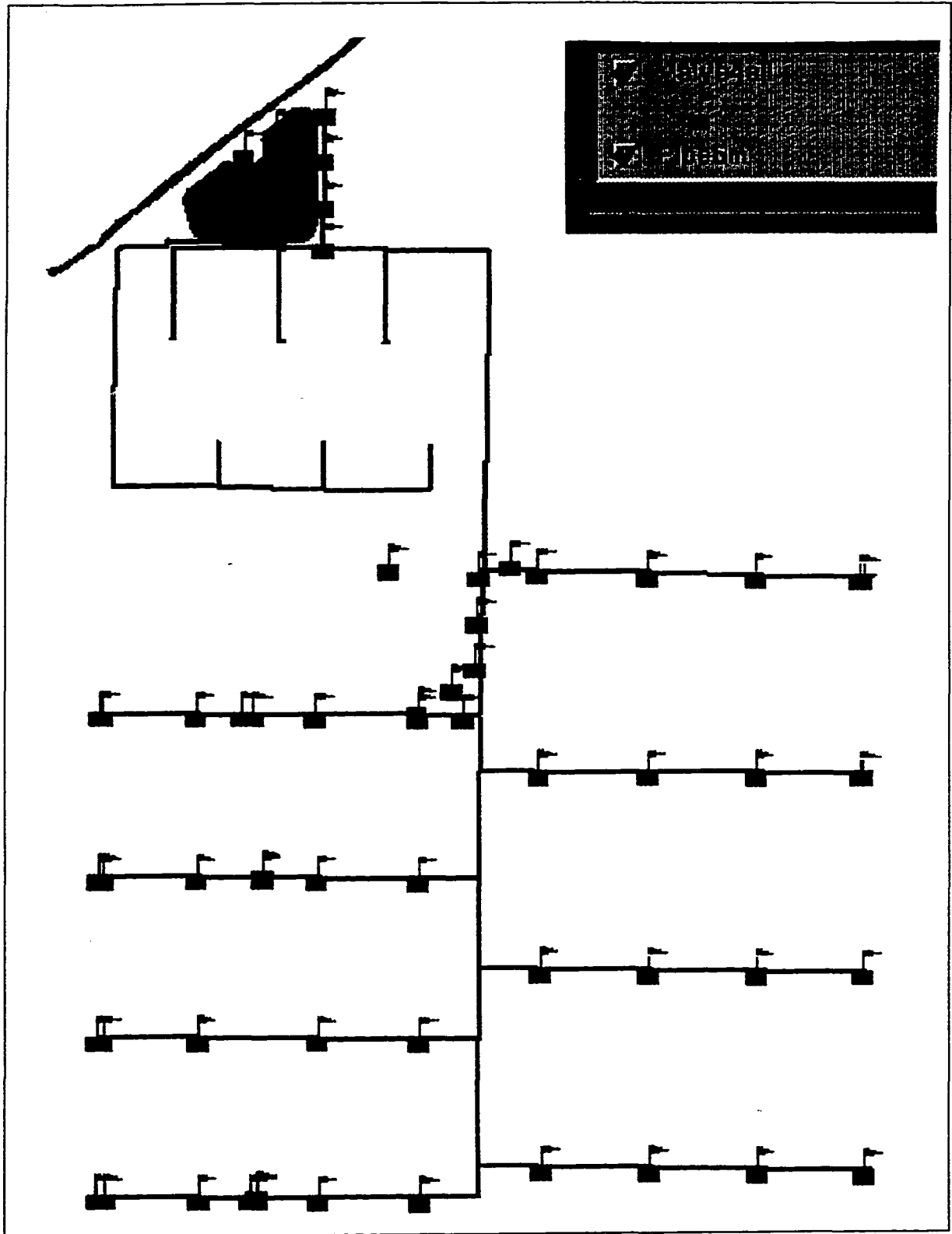

**Figure 3.6 ARDEC - Valves and main pipe distribution system lay-out**

C = Hazen Williams coefficient

D = pipe diameter, L

At ARDEC, friction head-loss in pipelines were computed using the Hazen-Williams equation, since this equation has a constant factor for each pipe material and are often used by the irrigation industry to calculate friction loss in pipes. Plastic pipes used in irrigation lateral lines are usually classified as "hydraulic smooth" pipe. The common recommended values of the Hazen-Williams roughness coefficient, C, will range from 130 and 150 regardless of the pipe diameter (Moghazi, 1998). The value of the Hazen-Williams coefficient used in the calculations of head-loss was assumed to be 140.

### **3.7 System Capabilities**

Scheduling personnel or crop managers must be aware of the capabilities in the irrigation supply system so that scheduling requests can be executed properly by the irrigators in the field. In this research, irrigation scheduling forecasts the timing and amount of water required to meet the water needs of the crop. The water available for irrigation may be limited in total volume or maximum flow rates by the physical system constraints or operational constraints.

The depth selected is one that best contributes to the management objective. The depth maybe dictated by the soil water holding capacity, the infiltration rate, the available flow rate, the limited working time of 10hrs a day and the irrigation system efficiency.

The water necessary to eliminate depletions is on a net basis. If the requested water allocation is not implemented for some reason, the implemented allocation must be

communicated back to the scheduling personnel so the necessary adjustments can be made prior to determining the next schedule and water allocation.

Good communication between the scheduler and irrigator regarding the requested allocation and the actual allocation is essential if the scheduling output is to be delivered and used. Irrigated areas are generally scheduled such that the soil water profiles are completely refilled at each irrigation. If this is not possible due to constraints in the system then the program recalculates the soil/water depletion for the next day taking into account that the soil/water profiles are not completely refilled at that irrigation.

The users can specify any field to either be irrigated on a selected day or not be irrigated on days when operations must be performed such as tillage, harvest or other cultural operation.

The major requirement of a water distribution system is the ability to deliver the water in sufficient quantities at the necessary frequency to maintain adequate soil water in the root zone throughout the entire irrigation system. If sufficient water is available to refill the profile, the scheduled irrigation is performed; otherwise, the user can specify fields to be either irrigated any day before or after the requested schedule.

### **3.8 Integration with Farming Operations**

Irrigation scheduling is one aspect of total farm management for crop production. The irrigation schedule indicates the labor required to accomplish the irrigation. The range of dates given for starting an irrigation, allows coordinating irrigation with other farming operations such as cultivating, spraying, fertilizing or harvesting, while minimizing the

risk of damaging crops by not applying adequate water in a timely manner. Total flow to several fields may be limited by the physical capacity of the system (pipe diameter, pump capacity, canal size, reservoir elevation, limited working day hours and shortage in water supply).

### **3.9 Results of the Irrigation Scheduling and Water Allocation**

The results of the irrigation scheduling and water allocation are presented in maps and tables conveying the following information.

- 1) Map showing crop lay out at ARDEC (see figure 3.2)
- 2) Map showing soil lay out at ARDEC (see figure 3.3)
- 3) Map showing the ARDEC irrigation system lay out (see figure 3.4)
- 4) Map showing the ARDEC pipe irrigation system lay out (see figure 3.5)
- 5) Maps showing the fields that needs to be irrigated at a given day. Figure 3.7 shows that on July 2nd the fields that needed to be irrigated are the ones colored light gray, i.e. fields number 100A, 100B, 100C, 600-1, 600-2, 400A and 400B (see figure 3.8 for the lay out of fields at ARDEC). The volume of water available was enough to supply the demand.
- 6) Maps and Tables showing quantity of irrigation water needed, current depletion, allowable depletion and crop evapotranspiration (see table 3.5 and 3.13). See item 3.9.3 for the explanation of table 3.13.
- 7) Tables showing the start and stop time for the application of water to each field (see table 3.3).

8) Tables indicating the number of hours of operation of each well and the surface diversion for which water is delivered in twenty-four hours increments (see table 3.4).

### 3.9.1 Verifying the Results of Daily Depletion using GIS and the SCHED Model

Daily depletion results for ARDEC running both the GIS and SCHED model are shown in tables 3.5, 3.6 and 3.7 for fields # 1030, 200A and 700 at ARDEC. Field # 1030 is located north of county road 56 and the other two south. (See figure 3.7 for field location information at ARDEC).

### 3.9.2 Comparing the GIS On-Farm Water Allocation Model with the SCHED Model

The USDA-ARS Irrigation Scheduling, SCHED program was developed with the objective of predicting time (day) and amounts of next irrigation. Knowing the current soil water depletion and an estimate of the future crop-water use, the time when the depletion reaches any specified level is calculated. The challenge is then to design a model to calculate crop-water requirements considering spatial and temporal variability with further allocation of a limited supply of water to meet crop water needs, minimizing stress and attaining high production. Having this in mind the GIS program presented in this academic research was developed.

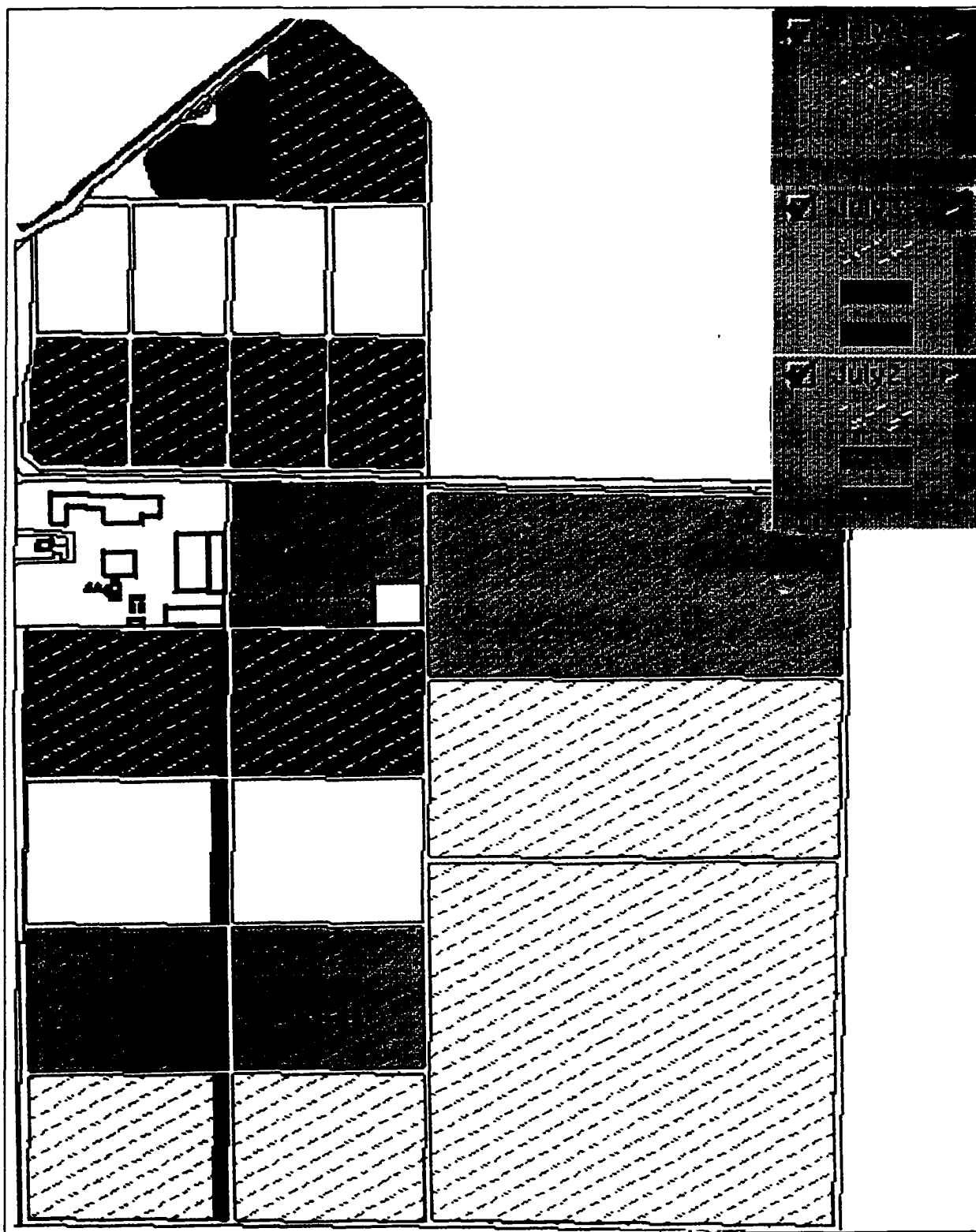

**Figure 3.7 ARDEC - Map showing water - allocation for July 1, July2, July3 and July4**

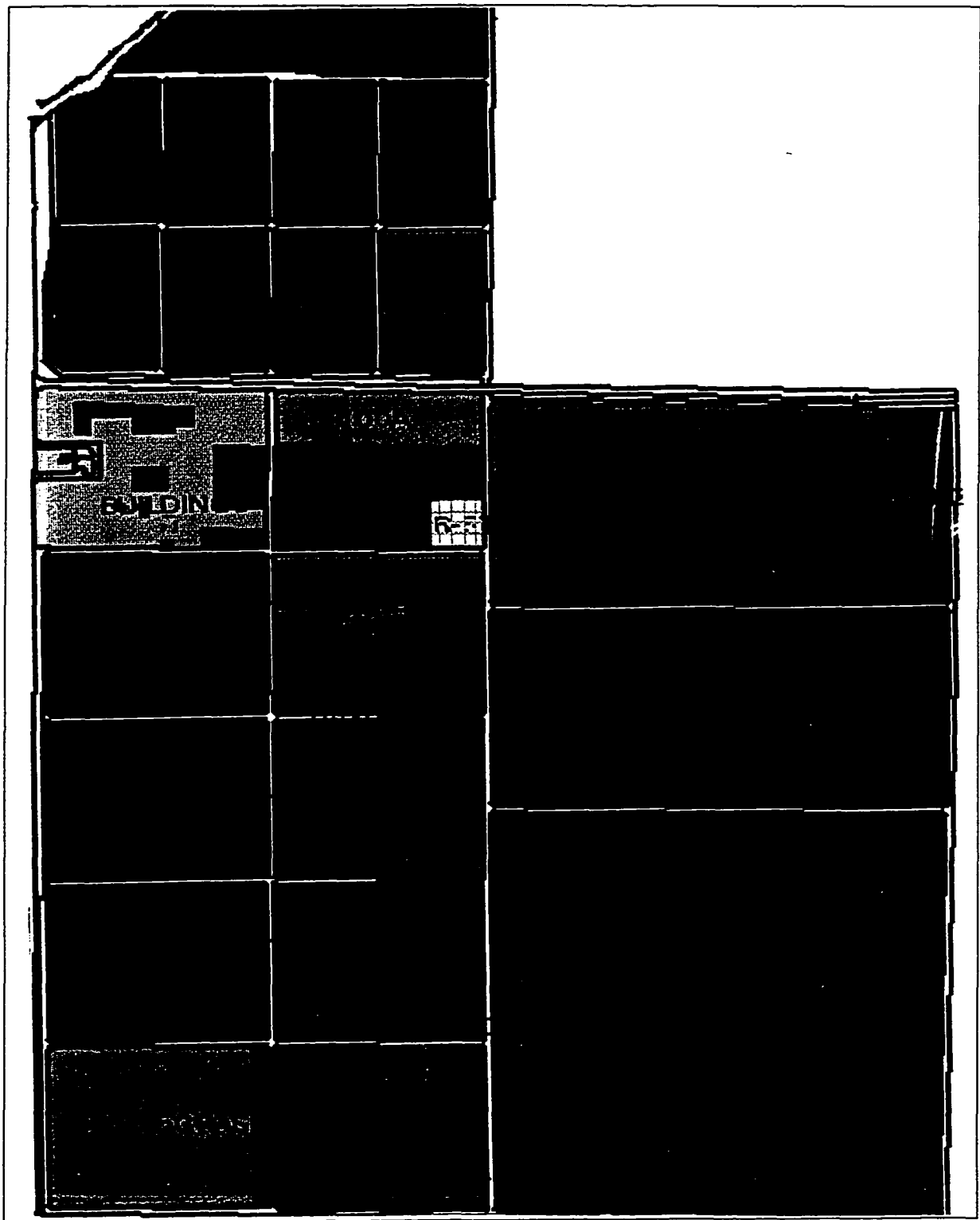

**Figure 3.8 ARDEC - Lay-out of fields overlaid by the soil map**

*Obs: Numbers on top of the map refers to field # at ARDEC*

*Number with a digit i.e. 700-1 refers to a field having two different soil types*

Table 3.3 Start and stop time for the application of water to each field - July 2

	t-irrigst	t-irrigsp	plot_doy
1	0	0	1090
2	0	0	RESERVOIR
3	0	0	ROADS
4	0	0	1050
5	0	0	1060
6	0	0	1070
7	0	0	1080
8	0	0	1010
9	0	0	1020
10	0	0	1030
11	0	0	1040
12	0	0	BUILDINGS
13			100A
14			600
15			600-2
16			100B
17			100C
18	0	0	WEATHER-STATION
19	0	0	200A
20	0	0	GRASS-UGT
21	0	0	200B
22	0	0	700-1
23	0	0	700-2
24	0	0	300A
25	0	0	GRASS-UGT
26	0	0	300B
27	0	0	800-1
28	0	0	800-2
29			400A
30	0	0	GRASS-UGT
31			400B
32	0	0	900-1
33	0	0	900-2
34	0	0	500A
35	0	0	GRASS-UGT
36	0	0	500B-1
37	0	0	500B-2
38	0	0	500B-3

obs: 1pm = 13, 2pm = 14, 3pm = 15, 4pm = 16, 5pm = 17, 6pm = 18  
 t-irrigst = irrigation start time, t-irrigsp = irrigation stop time,  
 field-doy = reference number for an ARDEC farm field

**Table 3.4 Number of hours of operation of each well and ditch water - July 2**

The advantages of using the GIS-BASED On-farm water allocation program presented here lies on the fact that this model performs not only calculation for crop-water requirements but allocates a limited supply of water based on crop-water-stress-sensitivity priority.

**Table 3.5 Estimated depletion calculated for a period of a month (June 14 - July 14), using SCHED and GIS programs - field# at ARDEC is 1030**

<b>PLOT # AT ARDEC = 1030 CROP = CORN</b>		
<b>DEPLETION</b>		
<b>DAY OF THE YEAR</b>	<b>GIS — PROGRAM</b>	<b>SCHED — PROGRAM</b>
	<b>(mm)</b>	<b>(mm)</b>
<b>JUNE 14</b>	1.5	1.5
<b>JUNE 15</b>	4.8	4.9
<b>JUNE 16</b>	9.7	9.7
<b>JUNE 17</b>	17.9	17.8
<b>JUNE 18</b>	26.1	25.9
<b>JUNE 19</b>	42.5	42.3
<b>JUNE 20</b>	0.0 — IRRIGATION	0.0
<b>JUNE 21</b>	9.1	8.2
<b>JUNE 22</b>	24.2	22.8
<b>JUNE 23</b>	30.7	28.7
<b>JUNE 24</b>	42.4	39.1
<b>JUNE 25</b>	0.0 — IRRIGATION	0.0
<b>JUNE 26</b>	4.2	4.5
<b>JUNE 27</b>	19.7	19.7
<b>JUNE 28</b>	26.5	26.0
<b>JUNE 29</b>	32.7	31.7
<b>JUNE 30</b>	0.0	0.0
<b>JULY 1</b>	16.7	16.7
<b>JULY 2</b>	44.1	44.0
<b>JULY 3</b>	0.0 — IRRIGATION	0.0
<b>JULY 4</b>	0.0	0.0
<b>JULY 5</b>	0.0 — RAIN	0.0
<b>JULY 6</b>	4.3	4.5
<b>JULY 7</b>	12.3	12.5
<b>JULY 8</b>	17.9	17.7
<b>JULY 9</b>	25.7	25.3
<b>JULY 10</b>	33.1	32.1
<b>JULY 11</b>	40.8	39.7
<b>JULY 12</b>	46.7	45.5
<b>JULY 13</b>	51.7	50.3
<b>JULY 14</b>	57.0	55.7

**Table 3.6 Estimated depletion calculated for a period of a month (June14 - July 14), using SCHED and GIS programs -- field# at ARDEC is 200A**

<b>PLOT # AT ARDEC = 200A CROP = CORN</b>		
<b>DEPLETION</b>		
<b>DAY OF THE YEAR</b>	<b>GIS -- PROGRAM</b>	<b>SCHED -- PROGRAM</b>
	<b>(mm)</b>	<b>(mm)</b>
<b>JUNE 14</b>	1.5	1.5
<b>JUNE 15</b>	4.8	4.9
<b>JUNE 16</b>	9.7	9.7
<b>JUNE 17</b>	17.9	17.8
<b>JUNE 18</b>	26.1	25.9
<b>JUNE 19</b>	42.5	42.3
<b>JUNE 20</b>	0.0 -- IRRIGATION	0.0
<b>JUNE 21</b>	9.1	8.2
<b>JUNE 22</b>	24.2	22.8
<b>JUNE 23</b>	30.7	28.7
<b>JUNE 24</b>	42.5	40.5
<b>JUNE 25</b>	0.0 -- IRRIGATION	0.0
<b>JUNE 26</b>	5.8	5.8
<b>JUNE 27</b>	21.3	21.0
<b>JUNE 28</b>	28.1	27.7
<b>JUNE 29</b>	34.3	32.9
<b>JUNE 30</b>	0.0	0.0
<b>JULY 1</b>	16.7	16.7
<b>JULY 2</b>	44.1	44.0
<b>JULY 3</b>	0.0 -- IRRIGATION	0.0
<b>JULY 4</b>	0.5	0.0
<b>JULY 5</b>	0.0 -- RAIN	0.0
<b>JULY 6</b>	4.3	4.5
<b>JULY 7</b>	12.3	12.5
<b>JULY 8</b>	18.0	18.6
<b>JULY 9</b>	25.8	26.5
<b>JULY 10</b>	33.2	33.6
<b>JULY 11</b>	40.9	41.1
<b>JULY 12</b>	46.8	46.8
<b>JULY 13</b>	51.7	51.7
<b>JULY 14</b>	57.1	57.0

**Table 3.7 Estimated depletion calculated for a period of a month (June14 – July 14), using SCHED and GIS programs -- field# at ARDEC is 700**

<b>PLOT # AT ARDEC = 700 CROP = BEANS</b>		
<b>DEPLETION</b>		
<b>DAY OF THE YEAR</b>	<b>GIS -- PROGRAM</b>	<b>SCHED -- PROGRAM</b>
	<b>(mm)</b>	<b>(mm)</b>
<b>JUNE 14</b>	1.5	1.5
<b>JUNE 15</b>	3.2	3.2
<b>JUNE 16</b>	5.5	5.5
<b>JUNE 17</b>	9.4	9.3
<b>JUNE 18</b>	13.1	12.9
<b>JUNE 19</b>	20.5	19.8
<b>JUNE 20</b>	21.9	20.9
<b>JUNE 21</b>	0.0 – IRRIGATION	0.0
<b>JUNE 22</b>	1.6	0.0
<b>JUNE 23</b>	3.5	3.9
<b>JUNE 24</b>	8.2	8.2
<b>JUNE 25</b>	0.0 -- IRRIGATION	0.0
<b>JUNE 26</b>	0.0	0.0
<b>JUNE 27</b>	4.2	4.2
<b>JUNE 28</b>	9.6	8.6
<b>JUNE 29</b>	13.9	12.3
<b>JUNE 30</b>	0.0	0.0
<b>JULY 1</b>	8.1	8.1
<b>JULY 2</b>	21.5	21.4
<b>JULY 3</b>	0.0 – IRRIGATION	0.0
<b>JULY 4</b>	0.0	0.0
<b>JULY 5</b>	0.0 – RAIN	0.0
<b>JULY 6</b>	8.1	7.9
<b>JULY 7</b>	14.2	14.5
<b>JULY 8</b>	17.8	16.9
<b>JULY 9</b>	22.7	20.8
<b>JULY 10</b>	27.1	24.6
<b>JULY 11</b>	0.0 – IRRIGATION	0.0
<b>JULY 12</b>	0.0	0.0
<b>JULY 13</b>	0.9	0.9
<b>JULY 14</b>	6.3	5.8

Most of the data needed to perform the calculations is incorporated into the model reducing considerably the data entry process. The description of the default databases incorporated into the model is described in chapter 2.

In designing this model, spatial variability of soils across the field is considered. Soil properties vary throughout the root zone causing yield variation within fields. The model uses a layered mass balance approach. Different values for water holding capacity are inherited from a database function of the soil type and root-depth. A flag associated with it will tell which value for WHC should be taken from this database to perform the necessary calculations according to the layer the roots actually are. In the SCHED program those values should be entered by the user according to the soil type.

Crop growth stages are divided in four and management allowable depletion values vary according to the crop growth stage. Those values are incorporated into the program and based on date ranges the program automatically recognizes in which crop growth stage we are, and inherit the right value needed for the calculations. Using the SCHED program one assumes a constant management allowable depletion value during the entire growing season, causing the results to be less certain.

Values for irrigation system efficiency vary spatially throughout the farm function of the irrigation system and are incorporated into the program. Again, using SCHED those values should be entered by the user and changed according to the irrigation system type. On the other hand using the GIS program most of the values needed for calculating crop-water requirements are inherited from default databases and have spatial and temporal attributes associated to them.

After calculating crop-water-requirements the program proceeds with the water allocation based on crop-water priority setting. SCHED calculates daily depletion and it is up to the user to enter dates, amount, flow-rate and duration of the irrigation.

In the crop-data file, the user should enter planting date for both the GIS and the SCHED program, nevertheless the GIS program proceeds with the calculation of the cover and harvest dates. Minimum and Maximum rooting depth are inherited from a default database incorporated in the program function of crop-type.

The area associated with each field and needed to perform water volume calculations are calculated by the GIS program. It then proceeds with the calculation of the flow rate needed for irrigation using the water volume needed for each field, infiltration rates of the soil and irrigation duration. With SCHED the user should calculate these values, and once irrigation is needed, date, the user should manually enter duration and depth. This is automatically set by the GIS program during the allocation process.

Table 3.8 shows the SCHED data file where the user should enter values. Tables 3.9 to 3.12 show the sequence of the most significant screens used by the GIS model to perform calculations with the respective explanation of which data are to be entered by the user or are automatically inherited from databases incorporated into the program.

### 3.9.3 Explanation of the GIS-Model Results - Water Conflict Resolution

When water is limited to only some crops in the field during a given day, the GIS program will automatically transfer the fields that were left without irrigation to the next day. If desired, the user has the option of specifying any field to be irrigated at any given

day before or after the requested schedule. The depletion is then automatically recalculated for that field

**Table 3.8 SCHED field-data-file**

Field	700-2	Minimum root depth	0.15 m
Desire to schedule	Y	Maximum root depth	0.90 m
Last update	6-19	Water holding capac.	.165
Depletion @ point 1	19.70 mm	Raingage number	1
Depletion @ point 2	19.70 mm	Discharge	1280 Lpm
Last field measurement	6-14	Area	1.4 ha
Meas. depl'n @ point 1	1.50 mm	Applic. efficiency	0.80
Meas. depl'n @ point 2	1.50 mm	System configuration	Full
Water use for season	18.2 mm	Mgmt. allow. depl.	.70
Net applic. for seas.	0.0 mm	Allow. depl. for prec.	0.0 mm
Deep percolation @ 1	0.00 mm	Min. time/revolution	0.0 hrs.
Deep percolation @ 2	0.00 mm	System direction	Forward
Growing degree days	0.0	Percent timer	100 %
Crop	BEANS	Resid. R/I amt. @ 1	0.00 mm
Planting date	6-10	Resid. R/I amt. @ 2	0.00 mm
Effective cover date	8-30	Since last R/I @ 1	5 days
Harvest date	9-18		
Root devel. date	6-20		

The results of the GIS program are shown in table 3.13 to 3.19, where:

**FIELD#-ARDEC** = reference number for an ARDEC farm field

**WATER-VOL** = the volume of water needed to irrigate an ARDEC field in cubic meters. Only 60% of the total water available to irrigate ARDEC can be used, the rest should be kept at the reservoir in case of an emergency.

**IRRIG-GROSS** = quantity of irrigation water needed in meters

**ALLOC-PREF** = Water delivery in increasing order

**Table 3.9 Sequence of screens used by the GIS model to perform calculations  
Module - 1**

**MODULE #1**

- 1) Enter day of the year (if not entered it is calculated automatically), do not forget to press the <return> key after answering the question
- 2) Enter desired date: month/day (this value should be entered)
- 3) Enter Et-ref, i.e., reference evapotranspiration
- 4) Field#-Ardec (automatically inherited from the value entered in the previous screen)
- 5) The time is (automatically give you the time you are running the model)

PLOT#-ARDEC?> 200A

**MODULE #1**

**GIS APPLIED TO FARM MANAGEMENT**

**DEVELOPED BY SILVANA DELLA MANNA**  
**PROGRAMMED BY SILVANA DELLA MANNA**

**IRRIGATION SCHEDULING AND WATER ALLOCATION POLYCY FOR CROPS**

ENTER REQUIRED CLIMATIC DATA

DAY OF YEAR: 60 . TODAY - DATE: 3/01

ET-REF 0.0066

ET-FORCAST: 0.0000

RAINGAGE # 2: 0.0

THE TIME IS = 15:54:33

**Table 3.10 Sequence of screens used by the GIS model to perform calculations  
Module - 2**

**MODULE #2**

- 1) Crop Name: (enter a crop, i.e., corn, sugar-beets etc.)
- 2) Date-Plant (enter the date you planted your crop: month/day)
- 3) Vegetative period date (if not known this value will be inherited from internal databases)
- 4) Flowering period date (if not known this value will be inherited from internal databases)
- 5) Yield formation period date (if not known this value will be inherited from internal databases)
- 6) Harvest period date (if not known this value will be inherited from internal databases)
- 7) Growing period for this crop is # (a number 1 to 4 is assigned automatically according to the growing period you actually are (1=vegetative, 2=flowering, 3=yield formation, 4=harvest) this values is inherited from databases internal to the program

**MODULE #2**

**DEFINING GROWING PERIOD FOR THE SELECTED CROP AT ARDEC**

**1=VEGETATIVE; 2=FLOWERING; 3=YIELD FORMATION; 4=HARVEST**

CROP NAME:	CORN
DATE-PLANT:	01/01/95
VEGETATIVE PERIOD DATE:	01/11
FLOWERING PERIOD DATE:	03/17
YIELD FORMATION PERIOD DATE:	04/26
HARVEST PERIOD DATE:	05/26
GROWING PERIOD FOR THIS CROP IS#:	2

**Table 3.11 Sequence of screens used by the GIS model to perform calculations  
Module - 3**

**MODULE #3**

- 1) Crop Name, already entered in the module #2, just type enter
- 2) Effective cover date, already entered in the module #2, just type enter
- 3) Effective harvested date already entered in the module #2, just type enter
- 4) Minimum root depth (m), this value if not entered is inherited from default databases
- 5) Maximum root depth (m), this value if not entered is inherited from default databases
- 6) Actual root depth (m), calculated using known algorithms already described previously in this research, chapter 2. After yield formation it is assumed that the root is at its maximum
- 7) Maximum depletion factor (f), this value if not entered is inherited from default databases
- 8) Water holding Capacity (m/m), this value if not entered is inherited from default databases
- 9) MAD-Management Allowable Depletion, calculated using known algorithms, function of rooting depth and water holding capacity
- 10) Depletion root zone previous day, calculated from irrigation scheduling equation and inherited from calculations performed in the previous day

**MODULE #3**

**EDIT CROP BASIC INFORMATION FOR PLOT# AT ARDEC**

**1=VEGETATIVE; 2=FLOWERING; 3=YIELD FORMATION; 4=HARVEST**

CROP NAME:	CORN
DATE-PLANT:	01/01/95
EFFECTIVE COVER DATE:	04/26
EFFECTIVE HARVEST DATE:	05/26
MINIMUM ROOT DEPTH:	0.150
MAXIMUM ROOT DEPTH:	1.200
ACTUAL ROOT DEPTH:	0.689
MAX-DEPLETION FCTOR (f):	0.400
WATER HOLDING CAPACITY IS:	0.170
MAD-MANAGEMENT ALLOWABLE DEPLETION:	0.047
DEPLETION ROOT ZONE PREVIOUS DAY:	0.003048

**Table 3.12 Sequence of screens used by the GIS model to perform calculations  
Module - 6**

**MODULE #6**

- 1) Depletion root zone previous day (this value is inherited from the depletion in the root zone in the previous day. In the case you want to set this value to zero just enter zero here)
- 2) Actual amount applied (it is the calculated water that should have been applied to the field. If a different amount has been applied, please enter the value here)
- 3) Cumulative water applied to this field to date (this value is automatically calculated from the information given by summing up previously irrigation applications)
- 4) Total depletion root zone since last irrigation
- 5) Amount of deep percolation
- 6) How much water to apply; gross irrigation that should have been applied to the field. It takes into account the irrigation system efficiency
- 7) Quantity of transient water available, (this is the deep percolation water that while moving down the soil profile is available for crop use)
- 8) Cumulative deep percolation, sum of the deep percolation for the entire season

**MODULE #6**

**CALCULATE HOW MUCH WATER TO APPLY – IRRIGATION NEEDED**

DEPLETION ROOT ZONE PREVIOUS DAY:	0.00304800
ACTUAL AMOUNT OF WATER APPLIED:	0.0000
CUMULATIVE WATER APPLIED TO THIS FIELD TO DATE:	0.00000000
TOTAL DEPLETION ROOT ZONE SINCE LAST IRRIGATION:	0.00631052
AMOUNT OF DEEP PERCOLATION TODAY (DAY 1 = 0):	0.00000000
HOW MUCH WATER TO APLY (CALCULATED):	0.0000
QUANTITY OF TRANSIENT WATER AVAILABLE:	0.00000000
CUMULATIVE DEEP-PERCOLATION:	0.00000000
THE TIME IS = 15:54:33	

T-IRRIGST	= irrigation start time
T-IRRIGSP	= irrigation stop time
T-IRRIG	= irrigation duration time
T-DITCHST	= ditch water delivery time start
T-DITCHSP	= ditch water delivery time stop
TSOUTHEST	= Southeast pump water delivery time start
TSOUTHESP	= Southeast pump water delivery time stop
TNORTHST	= North pump water delivery time start
TNORTHSP	= North pump water delivery time stop

Table 3.13 shows that at June 18 water was abundant and only a few fields needed to be irrigated, (100A, 100B and 100C). Field 900 did not need to be irrigated at this date. Table 3.14 shows that at June 19 many fields need to be irrigated including field 900 but water was limited and only few fields could be irrigated. So the user specified field 900 to be irrigated on a previous date, i.e., June 18, see table 3.15 and figure 3.9. Field # 900 is now included to be irrigated at June 18. Table 3.16, June 19 shows fields needing irrigation. Field# 900 does not appear in the list anymore.

Table 3.17 shows the fields that need to be irrigated on July 3. Water was restricted to some fields, which had highest irrigation priority. Figure 3.10 shows the fields that needed to be irrigated on July 3 and figure 3.11 show the fields that were actually irrigated. The other fields that were left without irrigation on July 3 were transferred to July 4.

Table 3.18 shows the fields that need to be irrigated on July 4 and the ones that were actually irrigated due to limited water supply. Figure 3.12 shows fields that need

irrigation on July 4 and figure 3.13 show the fields that were irrigated. Water was not available to supply the total crop-water requirements. Only a few fields were irrigated at that date. The others were automatically transferred to July 5.

At July 5 a rain occurred, so some of the fields were brought back to field capacity and did not need an irrigation, the others that were left without irrigation on July 4 and remained below MAD were irrigated on July 5.

Table 3.19 shows the fields that need to be irrigated on July 5. At this date water was available to supply the required demand. Figure 3.14 shows the fields to be irrigated on July 5.

### **3.10 Model Uncertainty**

Assumptions drawn upon by a method can be compromised. In uncertain domains, systems must be able to consider the adequacy of information provided by the user. The system developed in this research is able to handle vague or missing information. This is often accomplished by using default values or making value assumptions in the absence of information. Obviously conclusions that are reached based upon default values or assumptions will be less certain than conclusions, which are reached, based upon complete and accurate site-specific information.

**Table 3.13 ARDEC--Fields that need to be irrigated -- and the ones that were actually irrigated--The date is June 18--It does not include field 900**

THE PLOTS THAT NEED TO BE IRRIGATED TODAY ARE:

SRECNO	PLOT#-ARDEC	WATER-VOL	IRRIG-GROSS	ALLOC-PREF
14	100A	429.22	0.0468	10.00
17	100B	436.47	0.0468	10.00
18	100C	341.90	0.0468	10.00

THE TOTAL VOLUME OF WATER NECESSARY TO IRRIGATE THOSE PLOTS IS (M):  
1,207.6

THE VOLUME OF WATER AVAILABLE TO IRRIGATE ARDEC TODAY IS:  
12,335.0

60% OF THIS VOLUME IS :  
7,401.0

THE RESULTS OF THE WATER ALLOCATION ARE AS FOLLO

THE DATE TODAY IS:

06/18

VOLUME AND IRRIG-GROSS VALUES ARE IN METERS

IRRIGATION TIME AND DURATION IS IN HOURS

SRECNO	PLOT#-ARDEC	VOLUME(CROP)	IRRIG-GROSS
14	100A	505.0	0.0550
17	100B	513.6	0.0550
18	100C	402.3	0.0550

SRECNO	PLOT#-ARDEC	T-IRRIGST	T-IRRIGSP	T-IRRIG
14	100A	11	16	5
17	100B	11	16	5
18	100C	11	16	5

PUMP AND DITCH TIMES ARE IN HOURS

START AND STOP TIME FOR THE DITCH IS:

SRECNO	TDITCHST	TDITCHSP
22	0	0

START AND STOP TIME FOR PUMPS ARE:

SRECNO	TSOUTHEST	TSOUTHESP	TNORTHST	TNORTHSP	TSOUTHWST	TSOUTHWSP
22	8	18	0	0	0	0

THE VOLUME OF WATER AVAILABLE FOR TOMORROW IS:

12,264.125

60% OF THIS VOLUME IS:

7,358.477

THE PLOTS BELOW SHOULD BE IRRIGATED TOMORROW :

NO SELECTED RECORDS IN THE SPECIFIED RANGE

**Table 3.14 ARDEC--Fields that need to be irrigated -- and the ones that were actually irrigated--The date is June 19--It includes field 900**

SRECNO	PLOT#-ARDEC	WATER-VOL	IRRIG-GROSS	ALLOC-PREF
2	1090	1,372.98	0.0567	2.00
9	1010	760.72	0.0598	2.00
10	1020	743.55	0.0598	2.00
11	1030	745.96	0.0598	2.00
12	1040	744.72	0.0598	2.00
20	200A	1,682.83	0.0598	2.00
22	200B	1,938.66	0.0673	2.00
33	900-1	193.59	0.1711	12.00
34	900-2	12,313.04	0.1600	12.00
35	500A	5,170.17	0.1821	20.00
37	500B-1	4,514.56	0.2048	20.00
38	500B-2	527.28	0.1924	20.00
39	500B-3	976.59	0.2040	20.00

THE TOTAL VOLUME OF WATER NECESSARY TO IRRIGATE THOSE PLOTS IS (M):  
31,684.6

THE VOLUME OF WATER AVAILABLE TO IRRIGATE ARDEC TODAY IS:  
12,264.1

60% OF THIS VOLUME IS :  
7,358.5

THE RESULTS OF THE WATER ALLOCATION ARE AS FOLLOW

SRECNO	PLOT#-ARDEC	VOLUME(CROP)	IRRIG-GROSS
2	1090	1,600.1	0.0660
9	1010	839.9	0.0660
10	1020	820.8	0.0660
11	1030	823.6	0.0660
12	1040	822.2	0.0660
20	200A	1,858.0	0.0660
22	200B	2,219.7	0.0770

SRECNO	PLOT#-ARDEC	T-IRRIGST	T-IRRIGSP	T-IRRIG
2	1090	11	17	6
9	1010	11	17	6
10	1020	11	17	6
11	1030	11	17	6
12	1040	11	17	6
20	200A	11	17	6
22	200B	9	16	7

PUMP AND DITCH TIMES ARE IN HOURS  
START AND STOP TIME FOR THE DITCH IS:

SRECNO	TDITCHST	TDITCHSP
22	0	0

START AND STOP TIME FOR PUMPS ARE:

SRECNO	TSOUTHWEST	TSOUTHWSP	TNORTHST	TNORTHSP	TSOUTHWST	TSOUTHWSP
22	8	17	0	0	0	0

**Table 3.15 ARDEC--Fields that need to be irrigated -- and the ones that were actually irrigated—The date is June 18—It includes field 900**

THE PLOTS THAT NEED TO BE IRRIGATED TODAY ARE:

\$RECNO	PLOT#-ARDEC	WATER-VOL	IRRIG-GROSS	ALLOC-PREF
14	100A	429.22	0.0468	10.00
17	100B	436.47	0.0468	10.00
18	100C	341.90	0.0468	10.00
33	900-1	120.00	0.1061	12.00
34	900-2	8,000.00	0.1040	12.00

THE TOTAL VOLUME OF WATER NECESSARY TO IRRIGATE THOSE PLOTS IS (M):

9,327.6

THE VOLUME OF WATER AVAILABLE TO IRRIGATE ARDEC TODAY IS:

12,335.0

60% OF THIS VOLUME IS :

7,401.0

THE RESULTS OF THE WATER ALLOCATION ARE AS FOLLOW

THE DATE TODAY IS:

06/18

VOLUME AND IRRIG-GROSS VALUES ARE IN METERS

IRRIGATION TIME AND DURATION IS IN HOURS

\$RECNO	PLOT#-ARDEC	VOLUME(CROP)	IRRIG-GROSS
14	100A	505.0	0.0550
17	100B	513.6	0.0550
18	100C	402.3	0.0550
33	900-1	124.5	0.1101
34	900-2	4,007.2	0.0521

\$RECNO	PLOT#-ARDEC	T-IRRIGST	T-IRRIGSP	T-IRRIG
14	100A	11	16	5
17	100B	11	16	5
18	100C	11	16	5
33	900-1	7	17	10
34	900-2	7	17	20

PUMP AND DITCH TIMES ARE IN HOURS

START AND STOP TIME FOR THE DITCH IS:

\$RECNO TDITCHST TDITCHSP

22 0 0

START AND STOP TIME FOR PUMPS ARE:

\$RECNO TSOUTHWEST TSOUTHWSP TNORTHST TNORTHSP TSOUTHWST TSOUTHWSP

22 8 4 10 23 0 0

THE VOLUME OF WATER AVAILABLE FOR TOMORROW IS:

12,147.453

60% OF THIS VOLUME IS:

7,288.469

THE PLOTS BELOW SHOULD BE IRRIGATED TOMORROW :

NO SELECTED RECORDS IN THE SPECIFIED RANGE

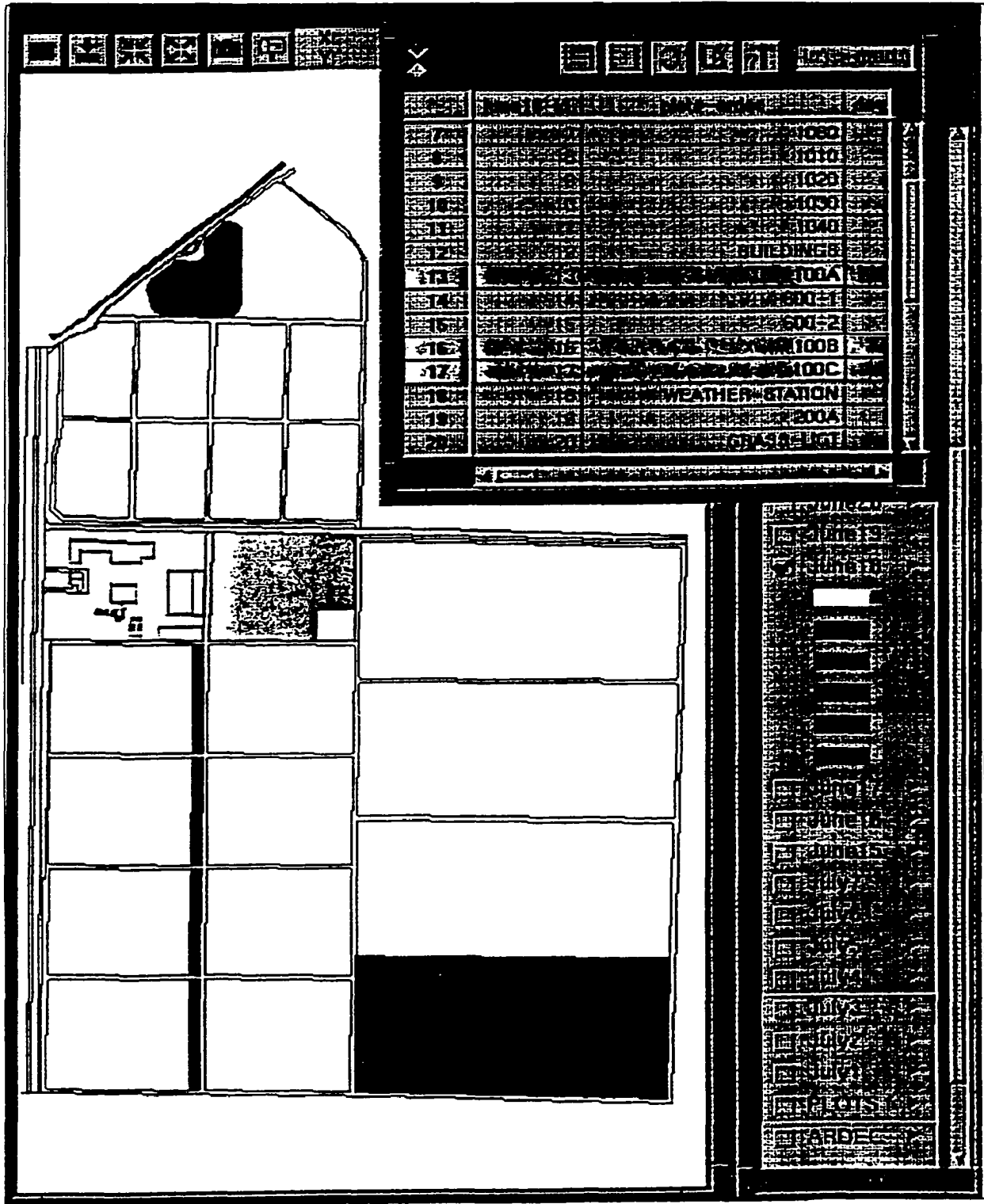

Figure 3.9 ARDEC -- Fields being irrigated--The date is June 18-- It includes field 900

**Table 3.16 ARDEC--Fields that need to be irrigated -- and the ones that were actually irrigated--The date is June 19--It does not include field 900 anymore**

\$RECNO	PLOT#-ARDEC	WATER-VOL	IRRIG-GROSS	ALLOC-PREF
2	1090	1,372.98	0.0567	2.00
9	1010	760.72	0.0598	2.00
10	1020	743.55	0.0598	2.00
11	1030	745.96	0.0598	2.00
12	1040	744.72	0.0598	2.00
20	200A	1,682.83	0.0598	2.00
22	200B	1,938.66	0.0673	2.00
35	500A	5,170.17	0.1821	20.00
37	500B-1	4,514.56	0.2048	20.00
38	500B-2	527.28	0.1924	20.00
39	500B-3	976.59	0.2040	20.00

THE TOTAL VOLUME OF WATER NECESSARY TO IRRIGATE THOSE PLOTS IS (M):  
19,178.0

THE VOLUME OF WATER AVAILABLE TO IRRIGATE ARDEC TODAY IS:  
12,147.5

60% OF THIS VOLUME IS :  
7,288.5

THE RESULTS OF THE WATER ALLOCATION ARE AS FOLLOW

VOLUME AND IRRIG-GROSS VALUES ARE IN METERS

IRRIGATION TIME AND DURATION IS IN HOURS

\$RECNO	PLOT#-ARDEC	VOLUME(CROP)	IRRIG-GROSS
2	1090	1,600.1	0.0660
9	1010	839.9	0.0660
10	1020	820.8	0.0660
11	1030	823.6	0.0660
12	1040	822.2	0.0660
20	200A	1,858.0	0.0660
22	200B	2,219.7	0.0770

\$RECNO	PLOT#-ARDEC	T-IRRIGST	T-IRRIGSP	T-IRRIG	TOMORROW
2	1090	11	17	6	
9	1010	11	17	6	THE VOLUME OF WATER
10	1020	11	17	6	12,230.578
11	1030	11	17	6	60% OF THIS VOLUME IS:
12	1040	11	17	6	7,338.348
20	200A	11	17	6	THE PLOTS BELOW SHOULD
22	200B	9	16	7	BE IRRIGATED

PUMP AND DITCH TIMES ARE IN HOURS

START AND STOP TIME FOR THE DITCH IS:

\$RECNO	TDITCHST	TDITCHSP	\$RECNO	PLOT#-ARDEC
22	0	0	35	500A
			37	500B-1
			38	500B-2
			39	500B-3

START AND STOP TIME FOR PUMPS ARE:

\$RECNO	TSOUTHEST	TSOUTHESP	TNORTHST	TNORTHSP	TSOUTHWST	TSOUTHWSP
22	8	17	0	0	0	0

**Table 3.17 ARDEC--Fields that need to be irrigated -- and the ones that were actually irrigated--The date is July 3**

<p>THE PLOTS THAT NEED TO BE IRRIG</p>		<p>THE RESULTS OF THE WATER ALLOCATION ARE AS FOLLO</p>						
\$RECNO	PLOT#-ARDEC	<p>THE DATE TODAY IS:</p>						
2	1090	<p>07/03</p>						
9	1010	<p>VOLUME AND IRRIG-GROSS VALUES ARE IN METERS</p>						
10	1020	<p>IRRIGATION TIME AND DURATION IS IN HOURS</p>						
11	1030	\$RECNO	PLOT#-ARDEC	VOLUME(CROP)	IRRIG-GROSS			
12	1040	2	1090	1,866.8	0.0770			
15	600-1	9	1010	979.9	0.0770			
16	600-2	10	1020	957.6	0.0770			
20	200A	11	1030	960.9	0.0770			
22	200B	12	1040	959.3	0.0770			
23	700-1	20	200A	2,167.7	0.0770			
24	700-2	22	200B	2,536.9	0.0881			
28	800-1	\$RECNO	PLOT#-ARDEC	T-IRRIGST	T-IRRIGSP	T-IRRIG		
29	800-2	2	1090	9	16	7		
30	400A	9	1010	9	16	7		
32	400B	10	1020	9	16	7		
35	500A	11	1030	9	16	7		
37	500B-1	12	1040	9	16	7		
38	500B-2	20	200A	9	16	7		
39	500B-3	22	200B	9	17	8		
<p>THE TOTAL VOLUME OF WATER NEC</p>		<p>PUMP AND DITCH TIMES ARE IN HOURS</p>						
<p>35,035.5</p>		<p>START AND STOP TIME FOR THE DITCH IS:</p>						
<p>THE VOLUME OF WATER AVAILABLE</p>		\$RECNO	TDITCHST	TDITCHSP				
<p>12,284.0</p>		22	0	0				
<p>60% OF THIS VOLUME IS :</p>		<p>START AND STOP TIME FOR PUMPS ARE:</p>						
<p>7,370.4</p>		\$RECNO	TSOUTHWEST	TSOUTHWSP	TNORTHST	TNORTHSP	TSOUTHWST	TSOUTHWSP
		22	8	4	0	0	0	0
		<p>THE VOLUME OF WATER AVAILABLE FOR TOMORROW IS:</p>						
		<p>12,271.016</p>						
		<p>60% OF THIS VOLUME IS:</p>						
		<p>7,362.609</p>						
		<p>THE PLOTS BELOW SHOULD BE IRRIGATED TOMORROW :</p>						
\$RECNO	PLOT#-ARDEC	<p>WATER-VOL</p>						
15	600-1	<p>3,136.2</p>						
16	600-2	<p>314.4</p>						
23	700-1	<p>2,630.6</p>						
24	700-2	<p>587.5</p>						
28	800-1	<p>1,377.9</p>						
29	800-2	<p>1,868.4</p>						
30	400A	<p>1,228.0</p>						
32	400B	<p>1,265.3</p>						
35	500A	<p>5,995.9</p>						
37	500B-1	<p>5,235.6</p>						
38	500B-2	<p>611.3</p>						
39	500B-3	<p>1,131.9</p>						

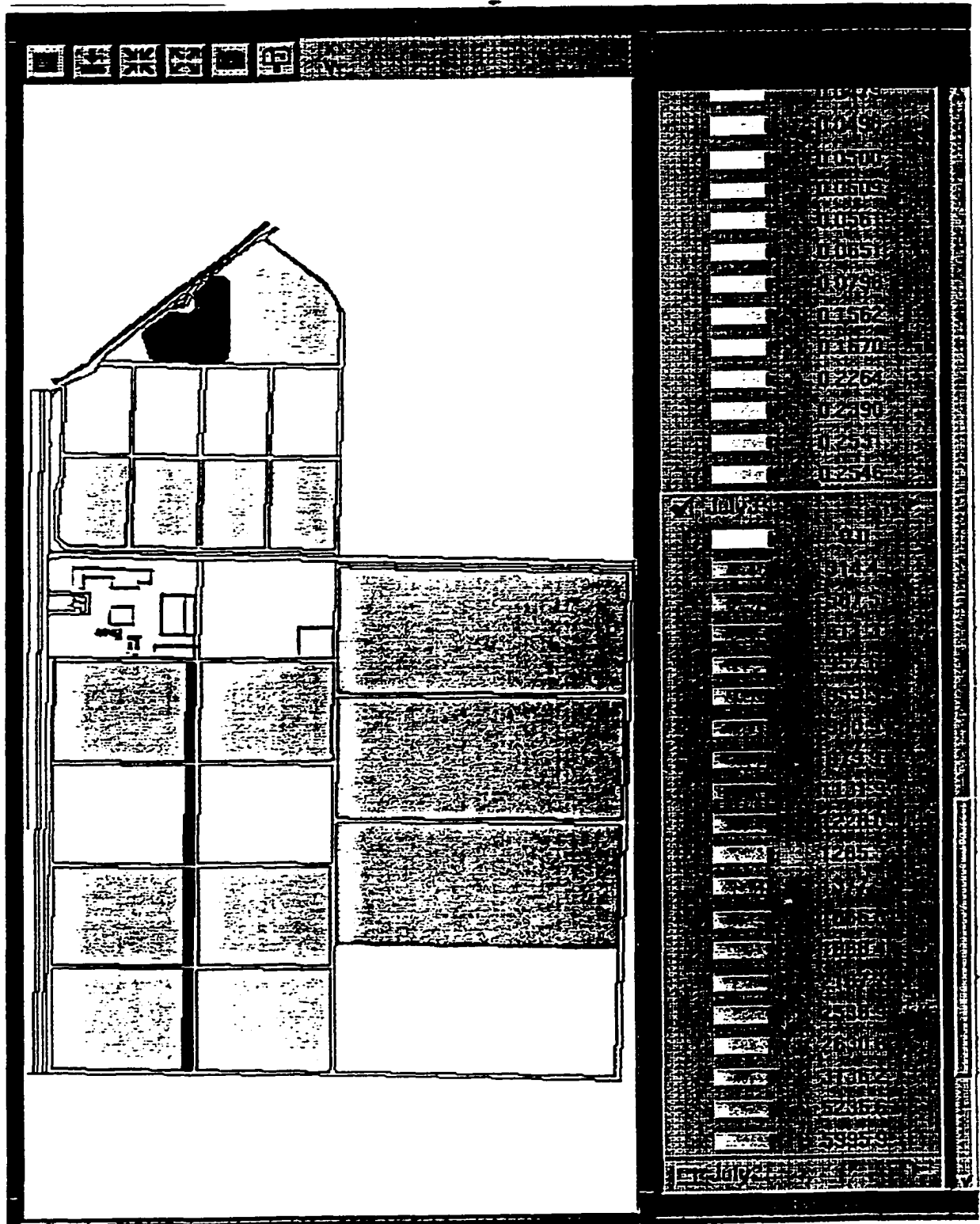

**Figure 3.10 ARDEC -- Fields that need to be irrigated--The date is July 3**

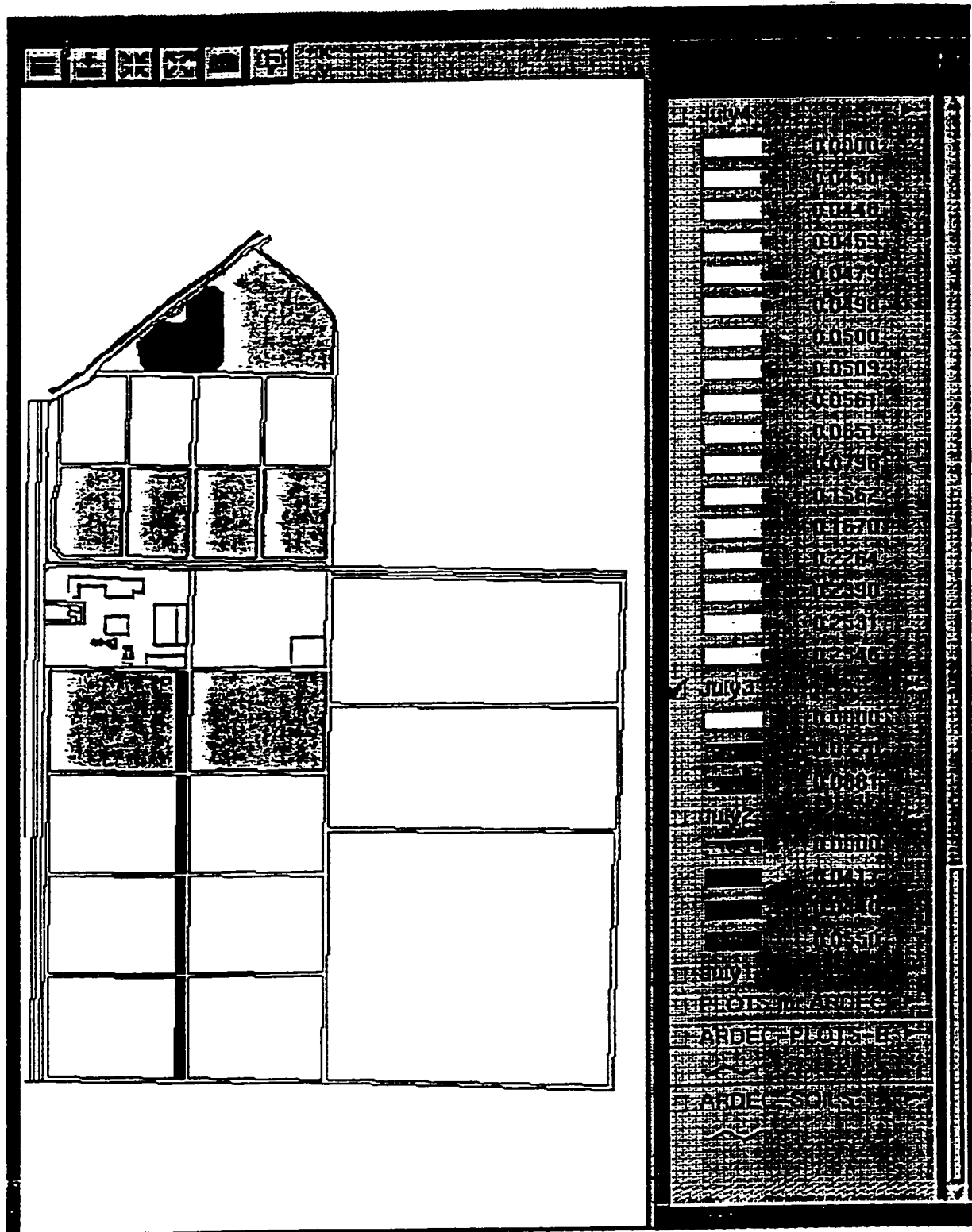

**Figure 3.11 ARDEC -- Fields actually being irrigated--water was limited  
The date is July 3**

**Table 3.18 ARDEC--Fields that need to be irrigated -- and the ones that were actually irrigated--The date is July 4**

		THE RESULTS OF THE WATER ALLOCATION ARE AS FOLLO						
		THE DATE TODAY IS:						
		07/04						
THE PLOTS THAT NEED TO BE IRRIG								
\$RECNO	PLOT#-ARDEC	VOLUME AND IRRIG-GROSS VALUES ARE IN METERS						
14	100A	IRRIGATION TIME AND DURATION IS IN HOURS						
15	600-1	\$RECNO	PLOT#-ARDEC	VOLUME(CROP)	IRRIG-GROSS			
16	600-2	15	600-1	6,163.8	0.0881			
17	100B	16	600-2	386.5	0.0521			
18	100C	23	700-1	3,400.5	0.0550			
23	700-1	24	700-2	691.0	0.0469			
24	700-2							
28	800-1	\$RECNO	PLOT#-ARDEC	T-IRRIGST	T-IRRIGSP	T-IRRIG		
29	800-2	15	600-1	9	17	8		
30	400A	16	600-2	7	17	10		
32	400B	23	700-1	11	16	5		
33	900-1	24	700-2	8	17	9		
34	900-2	PUMP AND DITCH TIMES ARE IN HOURS						
35	500A	START AND STOP TIME FOR THE DITCH IS:						
37	500B-1	\$RECNO	TDITCHST	TDITCHSP				
38	500B-2	22	0	0				
39	500B-3							
THE TOTAL VOLUME OF WATER NEC		START AND STOP TIME FOR PUMPS ARE:						
43,319.8		\$RECNO	TSOUTHEST	TSOUTHESP	TNORTHST	TNORTHSP	TSOUTHWST	TSOUTHWSP
THE VOLUME OF WATER AVAILABLE		22	8	4	10	11	0	0
12,271.0		THE VOLUME OF WATER AVAILABLE FOR TOMORROW IS:						
60% OF THIS VOLUME IS :		12,263.125						
7,362.6		60% OF THIS VOLUME IS:						
		7,357.875						
		THE PLOTS BELOW SHOULD BE IRRIGATED TOMORROW :						
\$RECNO	PLOT#-ARDEC							
14	100A	35	500A					
17	100B	37	500B-1					
18	100C	38	500B-2					
28	800-1	39	500B-3					
29	800-2							
30	400A							
32	400B							
33	900-1							
34	900-2							

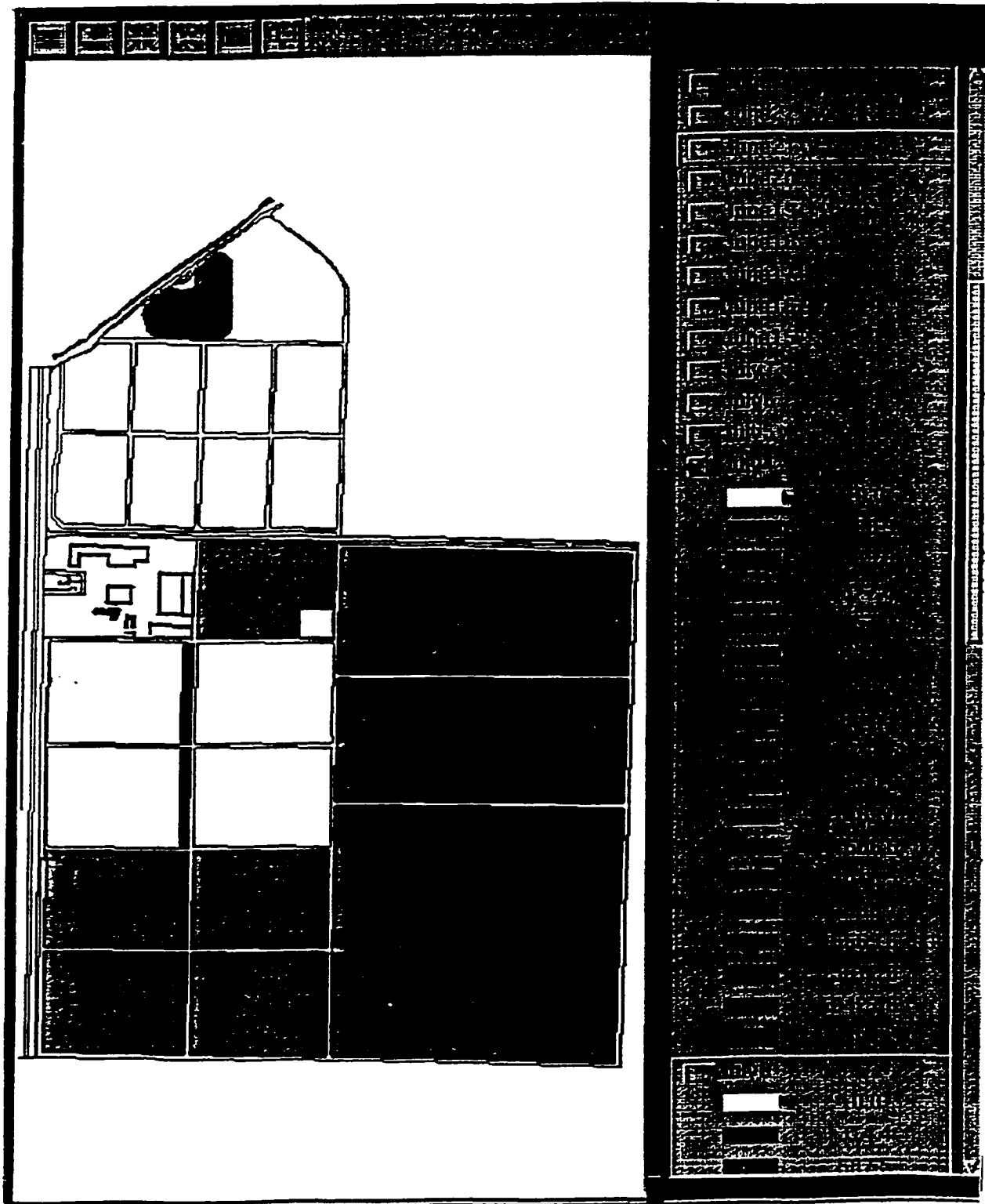

**Figure 3.12 ARDEC -- Fields that need to be irrigated--The date is July 4**

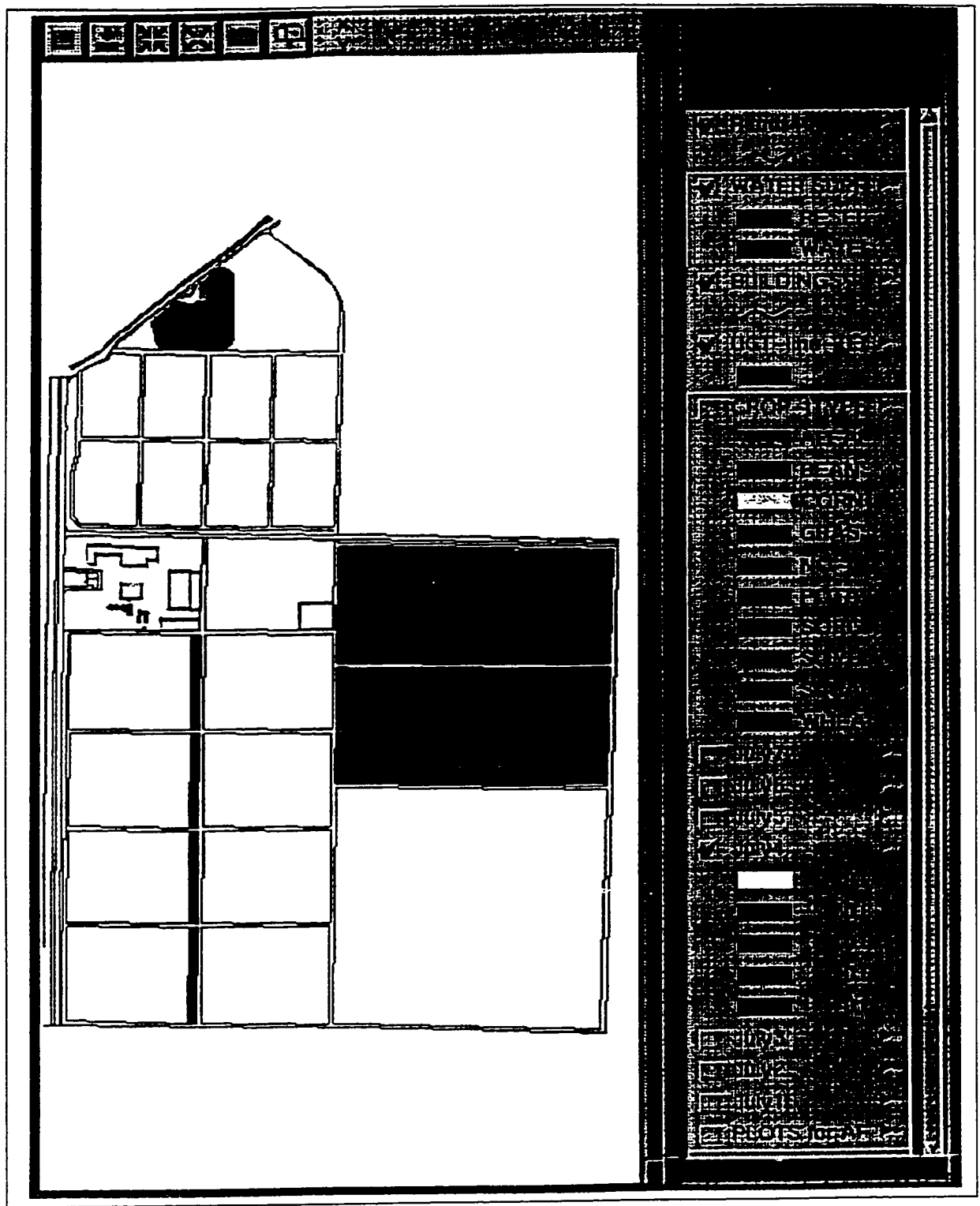

**Figure 3.13 ARDEC -- Fields actually being irrigated--water was limited  
The date is July 4**

**Table 3.19 ARDEC--Fields that need to be irrigated--and the ones that was actually irrigated on July 5 - Water was available to supply requested demand**

\$RECNO	PLOT#-ARDEC	WATER-VOL	IRRIG-GROSS	ALLOC-PREF
14	100A	458.98	0.0500	10.00
17	100B	463.43	0.0497	10.00
18	100C	365.64	0.0500	10.00
35	500A	6,219.99	0.2190	20.00
37	500B-1	5,431.26	0.2464	20.00
38	500B-2	633.01	0.2310	20.00
39	500B-3	1,169.66	0.2443	20.00

THE TOTAL VOLUME OF WATER NECESSARY TO IRRIGATE THOSE PLOTS IS (M):  
14,742.0

THE VOLUME OF WATER AVAILABLE TO IRRIGATE ARDEC TODAY IS:  
12,263.1

60% OF THIS VOLUME IS :  
7,357.9

THE RESULTS OF THE WATER ALLOCATION ARE AS FOLLO

\$RECNO	PLOT#-ARDEC	VOLUME(CROP)	IRRIG-GROSS
14	100A	505.0	0.0550
17	100B	513.6	0.0550
18	100C	402.3	0.0550
35	500A	3,125.5	0.1101
37	500B-1	2,425.9	0.1101
38	500B-2	142.7	0.0521
39	500B-3	526.9	0.1101

\$RECNO	PLOT#-ARDEC	T-IRRIGST	T-IRRIGSP	T-IRRIG
14	100A	11	16	5
17	100B	11	16	5
18	100C	11	16	5
35	500A	7	17	20
37	500B-1	7	17	23
38	500B-2	7	17	45
39	500B-3	7	17	23

PUMP AND DITCH TIMES ARE IN HOURS

START AND STOP TIME FOR THE DITCH IS:

\$RECNO	TDITCHST	TDITCHSP
22	0	0

START AND STOP TIME FOR PUMPS ARE:

\$RECNO	TSOUTHEST	TSOUTHESP	TNORTHST	TNORTHSP	TSOUTHWST	TSOUTHWSP
22	8	4	10	21	0	0

THE VOLUME OF WATER AVAILABLE FOR TOMORROW IS:  
12,313.039

60% OF THIS VOLUME IS:  
7,387.820

THE PLOTS BELOW SHOULD BE IRRIGATED TOMORROW :

\$RECNO	PLOT#-ARDEC	WATER-VOL
38	500B-2	142.7

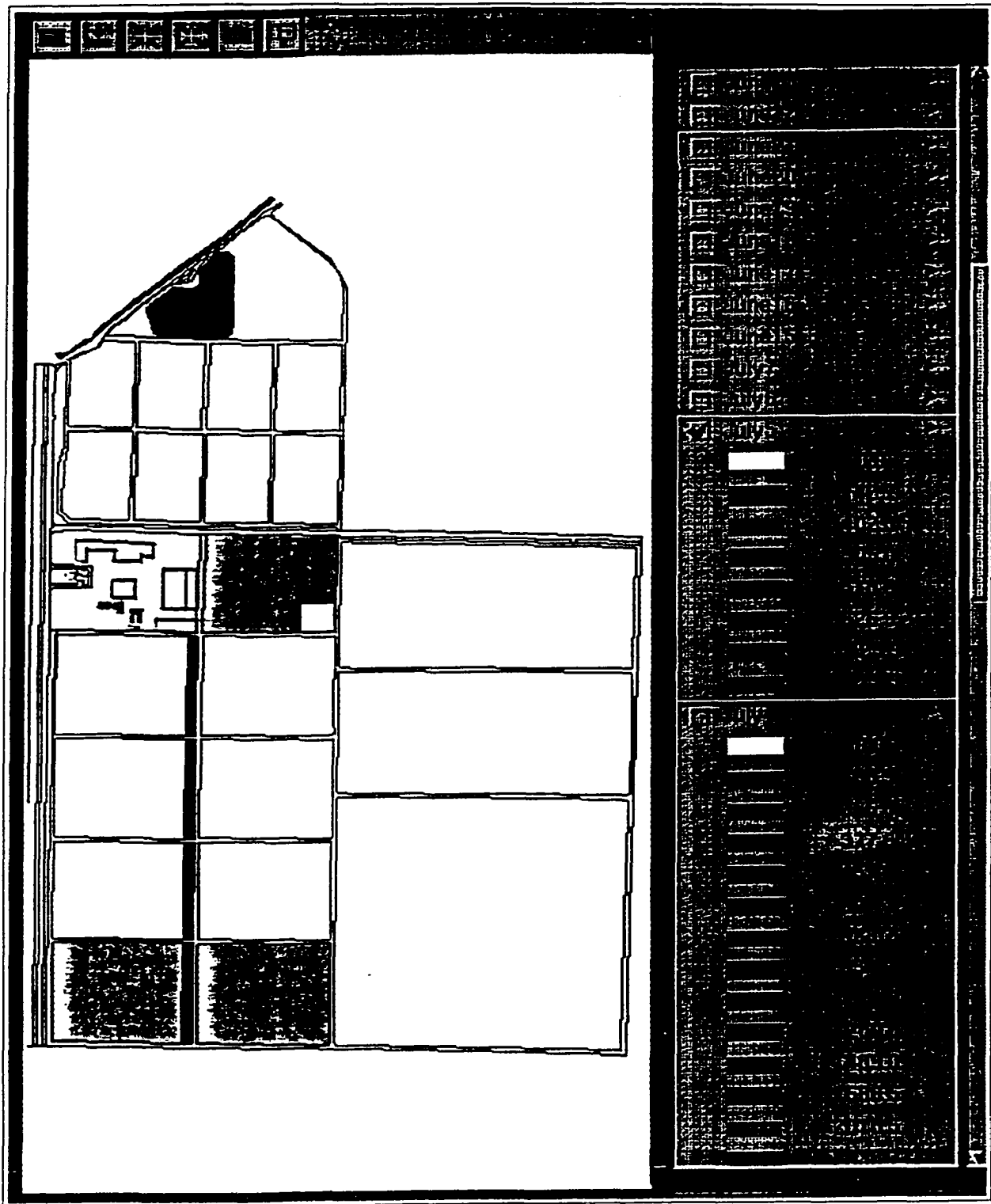

**Figure 3.14 ARDEC -- Fields that need to be irrigated--The date is July 5  
 --Water was available to supply requested demand**

## **CHAPTER 4**

### **SUMMARY AND CONCLUSIONS**

#### **4.1 An Overview of System Design**

The goal of this research was to develop a GIS-based crop management system to assist farmers to maintain or increase yields while minimizing yield reduction due to limited water supply.

This goal is broken down into the following objectives:

- 1) The development of a GIS-based irrigation scheduler to recommend the amount and timing of irrigation applications on a daily basis, considering spatial variability, and differences in resistance to crop-water stress.
- 2) The development of a crop-water priority system based on crop's sensitivity to water stress.
- 3) The development of a water allocation routine to satisfy crop water requirements using available water and system's physical capacity.
- 4) The development of a GIS system that can be easily used by the decision maker in charge of the farm system.

The methodology was applied to a 200 acres farm located in Larimer County, Colorado at the intersection of I-25 Frontage Road and County Road 56 i.e. AIRDEC farm.

Precise irrigation scheduling is specially required under conditions of limited water resources, where shortages require a refined timing of irrigation in order to minimize yield reductions. Additionally, close monitoring of the soil moisture status and knowledge of crop-soil water status is required to develop reliable irrigation scheduling methods.

A GIS system was incorporated to calculate and analyze irrigation scheduling and map the spatial distribution and allocation of the available water. It provides the capabilities for handling spatial variability in crop production. Irrigation demands varies from field to field because of soil water holding capacity variability and different crops and growth stages.

The system here developed has the capability to:

- 1) Identify spatial and temporal crop production performance
- 2) Organize, update and query a detailed map information system
- 3) Allocate water based on a priority list of tolerant crops to water stress
- 4) Access how the scheme performs on a daily basis and displaying the results in form of maps, tables and graphs.

## **4.2 Model Evaluation and General Conclusions**

Limited water can be allocated with the demand based on spatial irrigation scheduling and limited by irrigation system capacity. Water allocation function based on crop sensitivity to water stress is used to set priorities within the allocation process..

Field parameters such as the irrigation efficiency, soil water holding capacity, root zone depth, crop coefficient, planting date, harvesting date and growing periods are all incorporated into the model to calculate soil-water content.

Allocation of a limited supply of water depends on factors such as net profit per unit yield, potential yield of the crop, the minimum depth of irrigation needed to get the potential yield from a crop and stress sensitivity factors.

A strength of the program is that you can reset soil water content any time during the season to improve the tracking. Furthermore a good feature of this model is that water demand can be variable from field to field.

The system has the flexibility required to represent many different farm management situations. If provided with adequate information, it should be applicable to most irrigated crops. Examples of this flexibility include the ability to query and display the results in form of maps with quantity of irrigation water allocated to each field and the option of specifying any field to be irrigated at any given day before or after the requested schedule with the depletion being automatically recalculated for that field. The model results presented in chapter 3, item 3.9.3 for the months of June and July are reasonable.

The irrigation scheduler uses a layered soil water mass balance. The use of spatial distributed data allows better understanding of how much water is being used and where water is most depleted.

Using GIS techniques and the Thiessen polygons' method to determine the area associated with measured precipitation, a rainfall map is created and included in the model. Irrigation demands can vary within a crop field due to the spatial variability and water

holding capacities of the soils. In this research spatial and temporal variability is considered.

### **4.3 Perspective for Farm Management**

The model computes the total amount of water applied to each crop field over the irrigation season quantified by the irrigation scheduler and the quantity of precipitation.

It seems likely that in the near future, water resources will continue to become scarcer and more expensive. As additional demands are placed upon the farmer, increased efficiency in agricultural production will become an imperative to farm profitability. As the cost associated with water use inevitably grows, farmers will find an economic as well as a social incentive to increase the efficiency in their production and water use and prevent losses that could also cause environmental pollution. This transition in philosophy from maximizing yields to maximizing return and save water will inevitably require increased crop management at the field level.

It seems that irrigation scheduling and on farm water allocation is well situated to become an increasingly important part of farm management. The demand for farm management systems will likely intensify because decision support tools are well suited to increasing the level of crop management on the field scale without substantially increasing time and labor costs. Also, training requirements for water managers will increase and computer diagnostic programs will be needed to assist in reaching management decisions.

Irrigation scheduling and on farm water allocation for crops are important because they can more readily match crop demand. This, in turn, increases the farm's economic viability and helps to prevent yield reduction problems. GIS-based irrigation scheduling and on farm water allocation are tools that can help us to meet the demands of agricultural production today and in the near future.

What makes Precision Farming possible is the use of GIS and related spatial technologies. Together they have positioned maps and mapped data squarely in agriculture's future by providing the procedures for discovering and handling spatial variability in crop production.

The rationale behind the model's development are not strictly oriented toward obtaining a definitive answer or an optimal solution but rather to be helpful as a "planning and advisory" tool which agricultural engineers, agronomists, farmers and other planners and managers can use in the analysis of alternative scenarios.

## REFERENCES

1. Abu-Taleb, M. F. and M. Murad (1999). Use of Focus Groups and Surveys to Evaluate Water Conservation Campaign. *Journal of Water Resources Planning and Management*, 125(2), 94-99
2. Al-Jamal, M. S., T. W. Sammis, S. Ball and D. Smeal (2000). Computing the crop water production function for onion. *Agricultural Water Management*, 46(1), 29-41
3. Allen R.G. (1990). Reference Evapotranspiration Calculation. Version 1.1. Utah State University Foundation, Logan, Utah 84322-4105. Department of Agricultural and Irrigation Engineering
4. Amarasinghe, U. A., R. Sakthivadivel and H. Murray-Rust (1998). Impact Assessment of Rehabilitation Intervention in the Gal Oya Left Bank, Research Report 18 - Colombo, Sri Lanka. International Irrigation Management Institute
5. ARC/INFO Command References (1998). ARC Command References-Commands J-Z The ESRI-Environmental Systems Research Institute Arc/Info publishing System. Printed in the United States of America
6. ARDEC-Soil Description (1986). Colorado State University-ARDEC farm Reports-Fort Collins Colorado
7. Bastiaanssen, W. G. M., D. J. Molden and A. Smit (1999). Remote Sensing and Hydrological Models for Performance Assessment in Sirsa Irrigation Circle, India. Research Report 27 - Colombo, Sri Lanka, International Water Management Institute
8. Batte, M. T. (2000). Factors influencing the profitability of precision farming systems. *Journal of Soil and Water Conservation*, 55(1), 12-18
9. Bernatowicz, S., S. Leszczynsky, and S. Tyczynska. (1976). The influence of transpiration by emergent plants on the water balance in lakes. *Aquat. Bot* 2:275-288
10. Berry, J.K. (1991). Class Notes-Short Course in GIS. Colorado State University

11. Berry, J.K. (1998a). Managing Field Variability-California Farm Tech Conference-Santa Barbara, California-January 26-27, 1998 - Article from Farm Tech online communication, Rincon Publishing, Carpinteria, California
12. Berry, J.K. (1998b). Who's Minding the Farm. GIS World Magazine Vol. II No.2 February 1998. Geoplace.com
13. Berry, J.K. (1999). Take Precision farming Beyond Pretty Maps. GIS World Magazine Vol. III No.10 October 1999. Geoplace.com
14. Beyazgul, M., Y. Kayam, and F. Engelsman, (2000). Estimation Methods for crop water requirements in the Gediz Basin of western Turkey. *Journal of Hydrology* 229, 19-26.
15. Buchleiter, G.W., and D.F. Heermann (1987). System Scheduling for Large Farming Operations. *Proceeding Specialty Conference of Irrigation and Drainage Division. ASCE*, pp 45-56. Portland, Oregon, July 28-30.
16. Buchleiter, G.W., H.R. Duke and D.F. Heermann, (1988). Computer Control of Center Pivot Irrigation System in Colorado and Oregon. *Proceeding International Conference on Irrigation System Evaluation and Water Management. Vol II* pp 901-1003. September 12-16, 1988 Wuhan, China
17. Buchleiter, G.W., H.R. Duke and D.F. Heermann, (1992). SCHED - a Dos -Based Irrigation Scheduling Program (V 2.01). Agricultural Engineering Research Center. Fort Collins, Colorado.
18. Camp, C. R. and E. J. Sadler (1998). Site-specific crop management with a center pivot. *Journal of Soil and Water Conservation*, 53(4), 312-314
19. Cassel, D. K., Wendroth, and D. R. Nielsen (2000). Assessing Spatial Variability in an Agricultural Experiment Station Field: Opportunities Arising from Spatial Dependence. *Agronomy Journal*, 92:706-714
20. Cross, P. R. (2000). Benefits of Flexible Irrigation Water Supplies. *Journal of Irrigation and Drainage Engineering. ASCE*, 125(5), 275-278
21. Doorenbos, J. and A. H. Kassam. (1979). Yield Response to Water. *FAO - Irrigation and Drainage Paper No. 33*. FAO, Rome, Italy.
22. Doorenbos, J. and A. H. Kassam. (1986). Yield Response to Water. *FAO - Irrigation and Drainage Paper No. 33*. FAO, Rome, Italy.
23. Doorenbos, J., and A. H. Kassam. (1991). Yield Response to Water. *FAO - Irrigation and Drainage Paper No. 33*. FAO, Rome, Italy.

24. Doorenbos, J. and W. O. Pruitt. (1975). Guidelines for predicting crop water requirements. FAO - Irrigation and Drainage Paper No. 24, FAO, Rome, Italy
25. Doorenbos, J. and W. O. Pruitt. (1977). Guidelines for predicting crop water requirements, FAO - Irrigation and Drainage Paper No. 24, FAO, Rome. Italy.
26. Doorenbos, J., W. O. Pruitt, in consultation with A. Aboukhaled, C. Van Den Berg, J. Damagnez, M. Frere, N. G. Dastane, O. M. Ashford and P. E. Rijtema. (1992). Guidelines for predicting crop water requirements. FAO - Irrigation and Drainage Paper No. 24, FAO, 4<sup>th</sup> ed. Rome, Italy - ISBN 92-5-100279-7.
27. Duke, H. R. (1988). Scheduling irrigations: A guide for improved irrigation water management through proper timing and amount of water application. USDA-SCS-ARS. Colorado Technical Bulletin. 91pp
28. Duke, H. R. (1991). Scheduling irrigations: A guide for improved irrigation water management through proper timing and amount of water application. USDA-SCS-ARS. 76pp
29. Ghahraman, D. and A.K. Sepaskhan, (1994). Optimum Water Deficit in Irrigation Management in Semi-Arid Region in Iran. 17<sup>th</sup> European regional Conference on ICID, Varna, Bulgaria, May, pp. 127-134
30. Green, P. J. and R. Sibson (1978). Computing Dirichlet tessellations in the plane. Computer Journal. 21, 168-173.
31. Hanks, R.J. (1983). Yield and water use relationships: an overview. In: Limitation in Efficient Water Crop Production. P.I. Taylor (ed.). American Society of Agronomy, Madison
32. Hargreaves, G. H. (1975). Moisture availability and crop production. Transactions of the ASAE-American Society of Agricultural Engineers. 18(5): 980-984
33. Heermann, D.F., G.J. Harrington and K.M. Stahl. (1984). Empirical Estimation of daily clear sky solar radiation. Journal of Applied Meteorology
34. Heermann, D.F., H.R. Haise, and R.H. Mickelson. (1976). Scheduling center pivot Sprinkler irrigation systems for corn production in eastern Colorado. Transactions of the ASAE 19(2): 284-287, 293
35. Heermann, D.F. and M.E. Jensen (1970). Adopting Meteorological Approaches in Irrigation Scheduling to high rainfall areas. National Irrigation Symposium Papers. pp. 001-010

36. Hess, T.M. (1994). IMS - Irrigation Scheduling Program (Version 1) [IMS]. Cranfield University, Silsoe, UK.
37. Hess, T.M. (1997). IMS - Irrigation Water Requirements (Version 2.01) [IWR]. Cranfield University, Silsoe, UK.
38. Heuvel, R. M. V. (1996). The promise of precision agriculture. *Journal of Soil and Water Conservation* 51(1) 38-40
39. Hiller, E.A. and R.N. Clark. (1971). Stress day index to characterize effects of water stress on crop yields. *Transaction of the ASAE*, pp. 757-761
40. ICID – FAO – Smith, M., L.S. Pereira, J. Berengena, B. Itier, J. Goussard, R. Ragab, L. Tollefson, and P. Van Hofwegen, (1995) The International Commission on Irrigation and Drainage and FAO - The Food and Agriculture Organization of the United Nations, Workshop on "Irrigation Scheduling: From Theory to Practice". 46<sup>th</sup> Meeting of the ICID - Executive Council in 12- 13 September 1995, Rome, Italy.
41. Israelsen, W. (1979). *Irrigation Principles and Practices*. John Wiley and Sons. New York, N.Y.
42. Jensen, M.E. (1968). *Water Consumption by Agricultural Plants, Water Deficits and Plant Growth*. T.T. Kozlowsky (ed.). Academic Press. New York. Vol. II. Pp. 1-22.
43. Jensen, M.E. (1980). *Design and Operation of Farm Irrigation Systems*. ASAE-Monograph number 3 in a series published by American Society of Agricultural Engineers.
44. Jensen, M.E., R.D. Burman and R.G. Allen (ed.). (1990). *Evapotranspiration and Irrigation water requirements*. ASCE-Manuals and Reports on Engineering Practice-No. 70. ASCE: New York, NY.
45. Kincaid, D. And D.F. Heermann (1974). *Scheduling irrigation using a Programmable Calculator*. USDA-ARS-NC-12. 55pp
46. Mangold, G. (1998). *Precision Farming Modernizes Conventional Techniques*. GIS World Magazine Vol. II No.2 February 1998. Geoplance.com
47. Mangold, G. (1999) *Aggies Learn GIS-Precision Farming Primer Teaches Site Specifics*. Successful Farming-online production May 1999. Meredith Corporation. Des Moines, Iowa
48. Martin, D.L. and J.R. Gilley. (1993). *Irrigation Water Requirements Chapter 2 of the SCS National Engineering Handbook*, Soil Conservation Service, Washington D. C. 284pp

49. Moghazi, Hosam El-Din M. (1998). Estimating of Hazen-Williams Coefficient for Polyethylene Pipes. *Journal of Transportation Engineering*, ASCE, 124(2), 197-199
50. Molden, D. J. and R. Sakthivadivel (1999). Water Accounting to Assess Use and Productivity of Water. *International Journal of Water Resources Development*, 15(1/2), 55-71
51. Moreland, D. C. (1980). Soil Survey of Larimer County Area, Colorado. Published by the National Cooperative Soil Survey. USDA-SCS and Forest Service in cooperation with the Agricultural Experiment Station.
52. Mulla, D. J., and J. S. Schepers, (1997). Key processes and properties for site-specific soil and crop management - pp.1-18. In F. J. Pierce and E. J. Sadler (ed.) *The site-specific management for agricultural systems*. ASA, CSSA, and SSSA, Madison, WI
53. Nielsen, D. R., O. Wendroth, and F. J. Pierce (1999). Emerging concepts for solving the enigma of precision farming research - pp. 303-318. In P. C. Robert and et al. (ed.) *Proceedings of the 4<sup>th</sup> International Conference on Precision Agriculture*. Minneapolis, Minnesota, 19-22 July 1998. ASA, CSSA, and SSSA, Madison, WI
54. Paul, S. (1998). Seasonal and intra-seasonal irrigation scheduling for multi-crop environment: A case study. *Journal of Irrigation and Drainage Engineering*, ASCE, 124(3), 135-144.
55. Paul, S., P. Sudhinandra Nath and D. Nagesh Kumar (2000). Optimal irrigation Allocation: A Multilevel Approach. *Journal of Irrigation and Drainage Engineering*, ASCE, 126(3), 149-156.
56. Penman, H.L. (1963). *Vegetation and hydrology*. Tech. Comm. No. 53. Commonwealth Bureau of Soils, Harpenden, England. 125pp.
57. Pereira, L.S. (1994). Yield Response to Water as Affected by Irrigation Scheduling. General report of the 17<sup>th</sup> European Regional Conference on ICID, Varna, Bulgaria, May. Pp. 1-19
58. Ripley, B. (1981). *Spatial Statistics*. Wiley, New York.
59. Robert P. C., R. H. Rust, and W. E. Larson (ed.) (1995). *Site Specific management for agricultural systems*. *Proceedings 2<sup>nd</sup> International Conference on Precision Agriculture*, Minneapolis, Minnesota, 27-30 March 1994. ASA, CSSA, and SSSA, Madison, WI
60. Sakthivadivel, R., S. Thiruvengadachari, U. Amerasinghe, W. G. M. Bastiaanssen and D. J. Molden (1999), *Performance Evaluation for Bhakra Irrigation System*. India

using Remote Sensing and GIS Techniques. Research Report 28 - Colombo, Sri Lanka, International Water Management Institute.

61. Shayya, W.H. and V.F. Bralts. (1991). Guide to SCS-microcomputer irrigation scheduling package: SCS-Scheduler version 2.0. Irrigation System Evaluation and Scheduling demonstration project. Michigan State University, Department of Agricultural Engineering. USDA-SCS JUA 65-5D21-5-008.
62. Sibson, R. (1980). Natural Neighborhood interpolation. In Geographical Methods for multivariate data (ed. V. D. Barnett). Wiley, Chichester, UK.
63. Smith, M., (1992). CROPWAT - A Computer Program for Irrigation planning and Management - version 5.7 - FAO Irrigation and Drainage Paper No. 46, FAO, Rome, Italy - pp126
64. Stafford, J. V. (ed.) (1997). Precision Agriculture. Proceedings 1<sup>st</sup> European Conference on Precision Agriculture, Warwick. U.K. BIOS Scientific Publishers, Oxford, UK.
65. Stafford, J. V. (1999). An investigation into the within-field spatial variability of grain. P. 353-361. In J. V. Stafford (ed.) Precision Agriculture '99, Proceedings 2nd European Conference on Precision Agriculture, Odense, Denmark. 11-15 July 1999. Sheffield Academic Press, Sheffield, UK.
66. Stegman, E. C., L. H. Schiele and A. Bauer. (1976). Plant water stress criteria for irrigation scheduling. Transactions of the ASAE 19(5): 850-855.
67. Stewart, J. I., R. J. Hanks. and J. P. Riley. (1977). Optimizing Crop Production through Control of Water and Salinity Levels in the Soil. Utah Water Research Laboratory. PRW 6-161-1
68. Sunantara, J. D., and J. A. Ramirez. (1997). Optimal stochastic multicrop seasonal and intraseasonal irrigation control. Journal of Water Resources Planning and Management, ASCE, 123(1), 39-48
69. Thompson, K. (1999). Amber Waves of Grain-The Age of Precision Agriculture Has Arrived. GIS World Magazine Vol III No.10 October 1999. Geoplace.com
70. Vedula, S., and D. Nagesh Kumar (1996). An integrated model for optimal reservoir operation for irrigation of multiple crops. Water Resources Research, 32(4), 1101-1108
71. Wardlaw, R. B., and J. M. Barnes, (1999). Optimal Allocation of Irrigation Water Supplies in Real-Time. Journal of Irrigation and Drainage Engineering, ASCE. 125(6), 345-354