

DISSERTATION

SYNTHESIS OF DESIGN OPERATION AND MANAGEMENT
OF SURFACE IRRIGATION CONVEYANCE SYSTEMS

Submitted by

Subramaniaiyer Sritharan
Department of Civil Engineering

In partial fulfillment of the requirements
for the Degree of Doctor of Philosophy
Colorado State University
Fort Collins, Colorado

Summer - 1984

COLORADO STATE UNIVERSITY

Summer, 1984

WE HEREBY RECOMMEND THAT THE THESIS PREPARED UNDER OUR
SUPERVISION BY Subramaniayer Sritharan
ENTITLED "Synthesis of Design Operation and Management of Surface
Irrigation Conveyance Systems,"
BE ACCEPTED AS FULFILLING IN PART REQUIREMENTS FOR THE
DEGREE OF Doctor Of Philosophy

Committee on Graduate Work

Donald S. Fadene

Daniel H. Senada

W. L. Hall

Wayne Clyma

Co - Adviser

E. V. Hutchinson

Co - Adviser

[Signature]

Department Head



ABSTRACT OF DISSERTATION

SYNTHESIS OF DESIGN OPERATION AND MANAGEMENT OF SURFACE IRRIGATION CONVEYANCE SYSTEMS

A theory for the design of conveyance systems, synthesizing with it the operation and management and set in an interdisciplinary mode is proposed. The theory involving eleven steps is required in the development of solutions to six basic problems hitherto inadequately addressed. These solutions are given in the following six modules of the dissertation:

- (i) Optimal Turnout Area Module,
- (ii) Turnout Area Water Requirement Module,
- (iii) Project Scale Farm Design Module,
- (iv) Ground Water Interaction Module,
- (v) Water Issue Strategy Module and
- (vi) Hydraulic Simulation Module.

The problem of optimal turnout area was studied using causal processes theory (of mathematical sociology). Independence models and first order Markovian dependence models describing farmer behavior in the turnout area were studied.

The turnout area water requirement problem was studied using a probability based design evapotranspiration computation procedure. Requirement depths were obtained by deriving optimal scheduling in space and time applying dynamic programming, using recent crop production functions and considering recent soil moisture stress models.

Water requirements in terms of depth were converted to flow requirements in an optimal manner considering the hydraulics of the application system again using a two stage programming approach. Requirement efficiency and deep percolation ratio functions were developed for level borders using a zero-inertia model for four different soil types and for furrows using SCS approaches for the use in the model.

Ground water interactions in the irrigated areas were studied using a linearized Boussinesq equation and Green's Function approach. Recharge excitation was represented by a finite Fourier series fitted to the excitations obtained using the developed deep percolation functions and the appropriate boundary conditions. Long term water table build up was studied using this approach for any detrimental effects due to application system design.

Different water issue strategies and their optimaility/acceptability were studied. The optimal strategy for a Rotational Water Issue (RWI) was that the rotations be as low in the hierarchy of the canal system as possible and the capacities depended on the irrigation intervals.

The problem of hydraulic simulation was studied using the linearized diffusive wave equation for canal flow. The integral method was found to compare well with the analytical solution and was used for the solution of the advance problem. Delay times in releasing fixed steps of flow were computed using this approach. The operational criteria and necessary control measures were developed.

The solution procedures were applied to a sample hypothetical project area and found to be applicable.

Subramaniaiyer Sritharan
Department of Civil Engineering
Colorado State University
Fort Collins, Colorado 80523
Summer, 1984

ACKNOWLEDGEMENTS

My deep and sincere thanks go to my mentor, Professor Everett V. Richardson for enabling me to undertake graduate studies at CSU, guiding me and for being more than an advisor. My sincere and deep gratitude to Professor Wayne Clyma shall always be expressed for his patience, meticulous guidance and for the warmth my family was afforded by him and his family. I would like to thank Professor W. A. Hall and Professor D. Sunada for serving in my committee and for helping me with numerous suggestions and ideas. Special thanks go to Dr. D. Fontane for joining my graduate committee and for the help rendered to me in using the code CSUDP.

Ms. Diane Maybon, the master hieroglyphist, translated my writings to a dissertation with incredible patience and I am grateful to her for the excellent job done in typing and organizing the material. I would like to thank Ms. Hanae Akari for drafting the figures in an excellent manner. My thanks also go to Ms. Dorothy Rein, Ms. Pam Hobbs and Ms. Cheryl Stevens for all the help rendered to me and for making ERC life all the more pleasant. My thanks are due to Dr. Mohan Reddy for being an excellent source of literature and for the helpful discussions. I shall also be thankful to Professor D. C. Boes, Dr. Daren Clyne and Ms. S. Srinivasan of the Department of Statistics, CSU, for the helpful discussions I have had with them. Thanks are also due to Omnia El-Hakim and Rashwan Ibrahim for their friendship and kindness.

The support of the Colorado State University Experiment Station Project and the Egypt Water Use and Management Project of USAID towards this study is very gratefully acknowledged.

The love of Raji and Mathangi has always been a great comfort and shall always be remembered as shall the love and sacrifices made by my parents and my brothers and sisters.

DEDICATION

To The Memory Of My Loving Father:

Mr. S. A. Subramaniaiyer

Who expired before the return of his oldest son
on October 15th, 1982.

TABLE OF CONTENTS

<u>CHAPTER</u>	<u>Page</u>
ABSTRACT.....	iii
ACKNOWLEDGEMENTS.....	v
DEDICATION	vii
TABLE OF CONTENTS	viii
LIST OF TABLES	xiv
LIST OF FIGURES	xvii
CHAPTER 1 - INTRODUCTION	1
1.1 Generalities	1
1.2 Statement Of The Problem	2
1.3 Objective And Scope Of The Study	3
1.4 Organization Of The Study	3
CHAPTER 2 - PROPOSED DESIGN PROCEDURE	5
2.1 Generalities	5
2.2 The Design Procedure	5
2.3 Modules Required	6
CHAPTER 3 - OPTIMAL TURNOUT AREA MODULE	9
3.1 Introduction	9
3.2 Literature Review	11
3.2.1 Generalities	11
3.2.2 Sociological Studies	12
3.2.3 Engineering Studies	19

TABLE OF CONTENTS (Continued)

<u>CHAPTER</u>	<u>Page</u>
3.3 A Probabilistic Systems Approach For Turnout Area Interactions	24
3.3.1 Generalities	24
3.3.2 A Mathematical Sociology Approach.....	25
3.4 Economic Analysis Of Turnout Area Sizes	57
3.5 Conclusions and Recommendations	67
CHAPTER 4 - TURNOUT AREA WATER REQUIREMENTS MODULE	70
4.1 Introduction	70
4.2 Review of Literature Of Evapotranspiration Modeling	70
4.2.1 Generalities	70
4.2.2 Transpiration Models	71
4.2.3 Evapotranspiration Models	72
4.3 Uncertainty In Water Requirements	81
4.3.1 Generalities	81
4.3.2 Random Variations In Evapotranspiration Due to Climatological Factor	82
4.3.3 Random Variations In Net Radiation	83
4.3.4 Variations in Cropping Schedules (Temporal)	89
4.3.5 Farmer Readiness Model	89
4.3.6 Variations in Groundwater Contributions To Water Requirements	91
4.3.7 Net Potential Crop Water Requirement Computer Code.....	92
4.4 Turnout Area Depth Requirements	98
4.4.1 Seasonal Scheduling Using Production Functions	98
4.4.2 Case of Depletions That Retain $K_a = 1$	104
4.4.3 Case of Deficient Water Supply	112

TABLE OF CONTENTS (Continued)

<u>CHAPTER</u>	<u>Page</u>
4.5 Applications of Multi Crop Irrigation Scheduling Model	117
4.5.1 Generalities	117
4.5.2 Optimal Irrigation Scheduling	125
4.6 Conclusions and Recommendations	135
CHAPTER 5 - PROJECT SCALE FARM DESIGN MODULE	137
5.1 Introduction	137
5.2 Literature Review	137
5.2.1 General	137
5.2.2 Hydraulic Performance Functions	138
5.2.3 Crop Production Functions Suitable For Project Scale Analysis	140
5.3 Project Scale Analysis Of Optimal Farm Decision Variables	141
5.3.1 Variations Of Soil Characteristics In A Project Area	141
5.3.2 Efficiencies Of The Conveyance Systems	141
5.3.3 Seepage Losses From Canals	142
5.3.4 Deep Percolation Limits	143
5.3.5 Effects Of The Application System Types On Project Performance	143
5.3.6 Formulation Of The Project Scale Decision Problem	145
5.4 Application Of The Approach	152
5.4.1 Project Details	152
5.4.2 Sub-Optimal Analysis	152
5.4.3 Project Scale Optimality	162
5.4.4 Optimal Solution vs Equitable Distribution	163
5.4.5 Operational Parameters Over The Season	163
5.5 Conclusions and Recommendations	173

TABLE OF CONTENTS (Continued)

<u>CHAPTER</u>	<u>Page</u>
CHAPTER 6 - GROUNDWATER INTERACTION MODULE	175
6.1 Introduction	175
6.2 Literature Review And Idealization Of The Water Table Movement Problem	176
6.3 Solution Approach - Green's Functions	181
6.3.1 Green's Function For The Homogeneous Problem	181
6.3.2 Convolution For General Excitation $P(t)$	182
6.4 Effects of Recharge Due To Irrigation On Water Table	183
6.4.1 A Finite Fourier Representation Of Recharge Events	183
6.4.2 General Solution With $P(t)$ Due To Irrigation	185
6.5 Head Variations Under The Main Canal	189
6.5.1 Flow Until Hydraulic Connection	189
6.5.2 Flow After Hydraulic Connection	190
6.6 Application Of The Solution Approach	195
6.6.1 Project Details	195
6.6.2 Formula For The Case For Given Initial Water Table Profile	197
6.6.3 Results	197
6.7 Conclusions and Recommendations	209
CHAPTER 7 - WATER ISSUE STRATEGIES	210
7.1 Introduction	210
7.2 Literature Review	210
7.3 General Analysis Of Water Issue Strategies	212
7.3.1 Possible Combinations	212
7.3.2 Some Basic Rotational Water Issue Strategy Concepts	212

TABLE OF CONTENTS (Continued)

<u>CHAPTER</u>	<u>Page</u>
7.3.3 Some Basic Continuous Water Issue Strategy Concepts	215
7.3.4 Rotational vs Continuous Water Issues	216
7.3.5 Physical Arrangements At The Terminal Systems	218
7.4 Application Of Proportional Distributions Strategy	223
7.5 Conclusions and Recommendations	225
CHAPTER 8 - HYDRAULIC SIMULATION MODULE	229
8.1 Introduction	229
8.2 Literature Review	230
8.3 An Integral Method With A Diffusive Scheme For Water Advance In Irrigation Canals.	231
8.3.1 Basic Equations	231
8.3.2 A Linearization Scheme	232
8.3.3 Transformed Equations	234
8.3.4 The Advanced Problem And The Analogy To Stefan Problem	235
8.3.5 Integral Method Solution For The Advance Problem	235
8.3.6 Comparison Of Results With Exact Solution	239
8.3.7 Sample Case	242
8.3.8 Rate Of Initial Advance vs Rate Of Flow Increase	242
8.3.9 System Response Times	244
8.3.10 General Formulae For Controlled Releases In Canals Of Finite Length	244
8.3.11 Integral Method For Contolled Releases	249
8.3.12 General Formula For Exponentially Varying Flows	251
8.3.13 Release Strategies	253
8.3.14 Maximization Of Rate Of Advance Problem Formulation	253
8.4 Development Of Operational Criteria	256
8.4.1 Generalities	256
8.4.2 Problem Formulation	256

TABLE OF CONTENTS (Continued)

<u>CHAPTER</u>	<u>Page</u>
8.4.3 Application of Water Issue Time Solution	258
8.5 Summary, Conclusion and Recommendations ..	259
CHAPTER 9 - GENERAL RESULTS OF THE OVERALL DESIGN PROCEDURE	267
9.1 General Results	267
9.2 Analysis Of The General Results	268
CHAPTER 10 - GENERAL CONCLUSIONS AND RECOMMENDATIONS	270
REFERENCES	271
APPENDICES	281
Appendix 3.1	282
Appendix 3.2	285
Appendix 3.3	287
Appendix 4.1	289
Appendix 4.2	299
Appendix 4.3	303
Appendix 5.1	307
Appendix 5.2	317
Appendix 6.1	324

LIST OF TABLES

<u>TABLE</u>		<u>Page</u>
3.3.1	Value of n At Which Maximum Probability Of Success Occurs	38
3.3.2	Ranges Of n_{Max}	39
3.4.1	Variation Of λ With n For EBTM	65
3.4.2	Variation Of λ With n For 2x2 MCM	66
4.3.1	Variation Of Farmer Readiness With Labor And Equipment Availability	93
4.3.2	Variation Of Farmer Readiness With Labor And Equipment Availability	94
4.3.3	Variation Of Farmer Readiness With Labor And Equipment Availability	95
4.3.4	Variation Of Farmer Readiness With Labor And Equipment Availability	96
4.3.5	Variation Of Farmer Readiness With Labor And Equipment Availability	97
4.3.6	Unstressed Crop Water Requirements For Corn	99
4.3.7	Unstressed Crop Water Requirements For Upland Rice	100
4.3.8	Unstressed Crop Water Requirements For Cotton	101
4.4.1	Cumulative ET Requirements For Corn	108
4.4.2	Scheduled Depths For Corn	110

LIST OF TABLES (Continued)

<u>TABLE</u>		<u>Page</u>
4.5.1	Crop Data For Optimal Water Allocation Analysis	126
4.5.2	Optimal Allocation Of Water For Multiple Cropped Areas - Case 1	127
4.5.3	Optimal Allocation Of Water For Multiple Cropped Areas - Case 2	128
4.5.4	Sensitivity Analysis Of Optimal Allocation W.R.T. Areas	129
4.5.5 (a)	Final Stagewise Decisions For Corn	130
4.5.5 (b)	Final Stagewise Decisions For Cotton	131
4.5.5 (c)	Final Stagewise Decisions For Rice	132
4.5.6	Optimal Irrigation Scheduling	133
5.4.1	Project Details	153
5.4.2	System 1 Details	156
5.4.3	System 2 Details	158
5.4.4	Soil Group Parameters	160
5.4.5	Constraints On-Farm Systems Parameters	164
5.4.6	Sub-Optimal Analysis For Area 1	165
5.4.7	Sub-Optimal Analysis For Area 2	165
5.4.8	Sub-Optimal Analysis For Area 3	166
5.4.9	Sub-Optimal Analysis For Area 4	166
5.4.10	Project Scale Optimal Distribution Of Water At Peak Requirement	167

LIST OF TABLES (Continued)

<u>TABLE</u>		<u>Page</u>
5.4.11	Distribution of Water At Peak Requirement Under Conditions Of Equity	168
5.4.12	Values of Design Variables At The Peak Requirement	168
5.4.13	Values of Application System Variables Area 1	169
5.4.14	Values of Application System Variables Area 2	170
5.4.15	Values of Application System Variables Area 3	171
5.4.16	Values of Application System Variables Area 4	172
6.6.1	Project Groundwater Hydraulic Parameters	198
6.6.2	Recharge Depths Due To Deep Percolation	199
6.6.3	Main Canal Boundary Condition Analysis	200
6.6.4	Main Canal Boundary Condition Analysis	201
7.3.1	Possible Combinations Of Water Issue Strategies	213
7.3.2	Comparison Of The Effects Due To CWI And RWI On Sub-Optimal Design Values For Level Border Systems	217
7.3.3	Results Of Flow Division By A Trapezoidal Weir From A Trapezoidal Canal	224
7.4.1	Flow Releases From Main Canal - System 1	226
7.4.2	Flow Releases From Main Canal - System 2	227
8.4.1	Response Time Results For Secondary Systems in System 1	260

LIST OF TABLES (Continued)

<u>TABLE</u>		<u>Page</u>
8.4.2	Response Time Results For Secondary Systems in System 2	261
8.4.3	Response Time Results For System 1	262
8.4.4	Response Time Results For System 2	263
8.4.5	Main System Operational Schedule For Peak Irrigation - System 1	264
8.4.6	Main System Operational Schedule For Peak Irrigation - System 2	265
9.1.1	Project Details	269
A 3.1	Results of EBTM With Beta Distribution with $\alpha = 3$ and $\beta = 2$	283
A 3.2	Results of EBTM With Beta Distribution with $\alpha = 5$ and $\beta = 3$	284
A 3.3	Results of 2x2 MCM With Required Fraction Of Success = .75	286
A 3.4	Results of 4x4 MCM	288
A 5.1.1	Simulation Results For Furrow Systems	316
A 5.2.1	Results of Simulation On Level Basins I = 0.1 Family, Mannings n = 0.15	319
A 5.2.2	Results of Simulation On Level Basins I = 0.5 Family	320
A 5.2.3	Results of Simulation On Level Basins I = 1.0 Family	321
A 5.2.4	Results of Simulation On Level Basins I = 1.0 Family	322
A 5.2.5	Results of Simulation On Level Basins I = 1.0 Family	323

LIST OF FIGURES

<u>FIGURE</u>		<u>Page</u>
2.2.1 (a)	Flow Chart	7
2.2.1 (b)	Flow Chart	8
3.2.1	Parallel and Perpendicular MFD	20
3.3.1	Basic Causal Processes Models	27
3.3.2	Variation of Probability For Percentage (Or More) Success = 0.70×100 With η and ξ	40
3.3.3	Variation of Probability For Percentage (Or More) Success = 0.75×100 With η and ξ	41
3.3.4	Variation of Probability For Percentage (Or More) Success = 0.80×100 With η and ξ	42
3.3.5	General Region Of Validity of l and j	49
3.3.6	Region Of Validity For The Case of $M/n > 1/2$	51
4.4.1	Root Depths For Crops During A Growing Season	107
4.5.1	Yield vs Seasonal Water Use For Cotton	119
4.5.2	Optimal Irrigation Policies For Cotton	120
4.5.3	Yield vs Seasonal Water Use For Corn	121
4.5.4	Optimal Irrigation Policies For Corn	122
4.5.5	Yield vs Seasonal Water Use For Upland Rice	123
4.5.6	Optimal Irrigation Policies For Upland Rice	124

LIST OF FIGURES (Continued)

<u>FIGURE</u>		<u>Page</u>
4.5.7	Optimal Depth Requirements For W = 1120 mm	134
5.3.1	A Typical Reservoir Irrigation Project	147
5.4.1	Idealized View Of The Project System	154
5.4.2	Idealized View of Secondary and Tertiary Conveyance Systems	155
6.2.1	Plan View Of A Typical Layout	177
6.2.2	Cross Sectional View Of Irrigated Area	178
6.5.1	Dimensionless Recharge and Front Arrival Time Curves	191
6.5.2	Water Table Fluctuations Below A Main Canal	196
6.6.1	Water Table Envelope Curves For System 1, Soil Group 1	202
6.6.2	Water Table Envelope Curves For System 1, Soil Group 2	203
6.6.3	Water Table Envelope Curves For System 1, Soil Group 3	204
6.6.4	Water Table Envelope Curves For System 1, Soil Group 4	205
6.6.5	Water Table Envelope Curves For System 2, Soil Group 1	206
6.6.6	Water Table Envelope Curves For System 2, Soil Group 2	207
6.6.7	Water Table Envelope Curves For System 2, Soil Group 2'	208
7.3.1	Layout Plan Of Field Canal System	219

LIST OF FIGURES (Continued)

<u>FIGURE</u>		<u>Page</u>
8.3.1	Comparison Of Integral Method Solutions With Analytical Solution (Q/Q_0 vs Distance)	243
8.3.2	Comparison Of Advance Rate And Rate Of Flow Change	245
8.3.3	Idealized Conveyance System Layout	254
8.3.4	Flow Curves At Points Of Distribution System	255
8.4.1	Typical Layout And Notations Of Travel Time	257
A 5.1.1	Profile Of Infiltrated Water	309
A5.1.2	Prediction Formula Performance For E_r For Furrows	315

CHAPTER 1
INTRODUCTION

1.1 GENERALITIES

Surface irrigation systems have been built and operated by mankind since early history. Canals convey diverted or stored water in relatively large quantities to individual farms and to fields to be spread or distributed to the crops in relatively small amounts. The composite system distributes the available water resources over the areal extent it is designed to serve. The pressures on efficient use of resources have increased especially in the case of water. In an irrigation system the final distributed amounts to the individual farms are small and non visible changes in the issue of water, which are more likely at that scale, when summed up lead to large changes in the project scale water requirement. At an individual scale for obvious reasons, farmers tend to be greatly concerned about the availability of water. In many systems the farmers, whether charged or not for the irrigation water, tend to over use water despite the concern they have for the availability of water. Thus, at an individual scale often times water is a resource in a qualitative sense rather than in a quantitative sense. The managers of delivery systems too appear to be having similar notions. Water management scientitsts wrestle essentially with this problem.

Large scale irrigation water delivery systems intertwine themselves with the bureacracy and the individual farmers, in a literal sense and once set, develop their own characteristics. Once an irrigation season begins, an area

with such a system becomes a matrix for physico-human interactions not only in a dual sense but with the numerous human sub-divisions in a multi-faceted sense. A first order subdivision of the human interactions results in the identification of the bureaucracy that manages the system and the individual farmers who are supposed to be the beneficiaries of the system. Associated with this schism is the division of the physical system. We tend to call the sub-systems below the points at which bureaucracy has no control over the distribution of water as the micro-systems and the rest of the system as the macro-system.

1.2 STATEMENT OF THE PROBLEM

The early designs of irrigation projects have tended to weigh more heavily on the macro system with simplistic assumptions about the nature of the micro system. The operational features were not given along with the design but evolved in their own way yielding to some extent to the wishes of the farmers. Water management programs were proposed to look into and solve the problems that arose due to such design procedures and also due to myriad reasons of sociological, economical, agronomic and engineering nature. Such water management programs logically tended to analyze the micro-systems. The macro-system was some times viewed as rigid defacto. Thus, sequentially, it is logical to analyze the designs of the macro-system using the concepts that have arisen due to the recent water management studies of the micro-system. Macro system design must emphasize the pressing nature of the water resource problem and must accommodate the aspects of physico-human interactions as well as the engineering aspects. This means that the macro-system design can only be done in an interdisciplinary mode.

1.3 OBJECTIVE AND SCOPE OF THE STUDY

The macro system design cannot be done disparately from the micro system design and behaviour. Since newer concepts have evolved in the micro system design, new theory for the macro system design are necessary using such concepts. Operational procedures are an essential part of the design package and need to be developed along with the physical system design.

Considering these, the objective of this study is to formulate a theory for the design of the macro system synthesizing with it the operation and management of the system and taking into account the following:

- (i) Farmer behavior in the micro systems;
- (ii) water resources constraints on the design;
- (iii) micro system design and operation;
- (iv) longterm effects on water table conditions due to irrigation;
- (v) acceptability of the modes of spatial water distribution;
- (vi) operability of the system; and
- (vii) optimality of the system.

1.4 ORGANIZATION OF THE STUDY

Some aspects of the macro system design are well known and have been dealt with in the related literature extensively. This study does not dwell on them. The study of the composite system in a micro manner in a project scale design procedure requires immense efforts and the necessary models need to be compact and be balanced between accuracy and the efforts required. With these two preliminaries in mind, this study hypothesizes a theory for the macro system design which requires general models and in the application

requires inputs from the various disciplines involved in the design. This theory is given in the next chapter. The models required for the theory is given in separate chapters each containing a module addressing a given aspect of design. Each chapter is complete in itself with respect to the presentation of solutions to the problem addressed to in the module. Each of these six modules has an application part where hypothetical project data are used to demonstrate the applicability of the models. The general results appear in the ninth chapter and in the tenth chapter general conclusions and recommendations are made.

CHAPTER 2

PROPOSED DESIGN THEORY

2.1 GENERALITIES

The design procedure hypothesized in the study emphasizes an interdisciplinary approach which is now recognized as one that is essential for a successful design. Any farm in the given project is not a separate entity by itself, but is one of many interacting farms in the project. The same recognition should be afforded to different irrigation projects in a region as long as there is distinguishable interaction between them. This problem is not addressed to in the procedure directly, but can be included through the input from the discipline of water resources. The procedure assumes a deterministic setting as far as the source water availability is concerned, and for those systems that show greater sensitivity with regard to the hydrological inputs, the methodology should be modified to accommodate the stochastic nature of the hydrological inputs.

2.2 THE DESIGN THEORY

The proposed design theory, since it is interdisciplinary, is set to receive inputs from other disciplines and the details are given in the different modules separately. The structure of the overall procedure is best explained by the flow chart given in Figures 2.2.1(a) and 2.2.1(b). The disciplines involved in the inputs are also given in the flow chart. The associated modules are sometimes given together for reasons of convenience.

2.3 MODULES REQUIRED

The procedure begins by addressing the issue of the optimal number of farmers who might be allowed to share a single turnout. This is called the Optimal Turnout Area Module. The problem of the determination of depth requirements over the season is described in Turnout Area Water Requirement Module. Once the depth of irrigation is determined, the conversion of this to the optimal application system design is described in the Project Scale Farm Design Module. The effect of the application system design on the water table build up is studied in the Ground Water Interaction Module. The spatial water issue strategies to deliver the farm design flows are described in the Water Issue Strategy Module. Finally, the hydraulic design parameters of the conveyance system and its operational features are obtained from the Hydraulic Simulation Module.

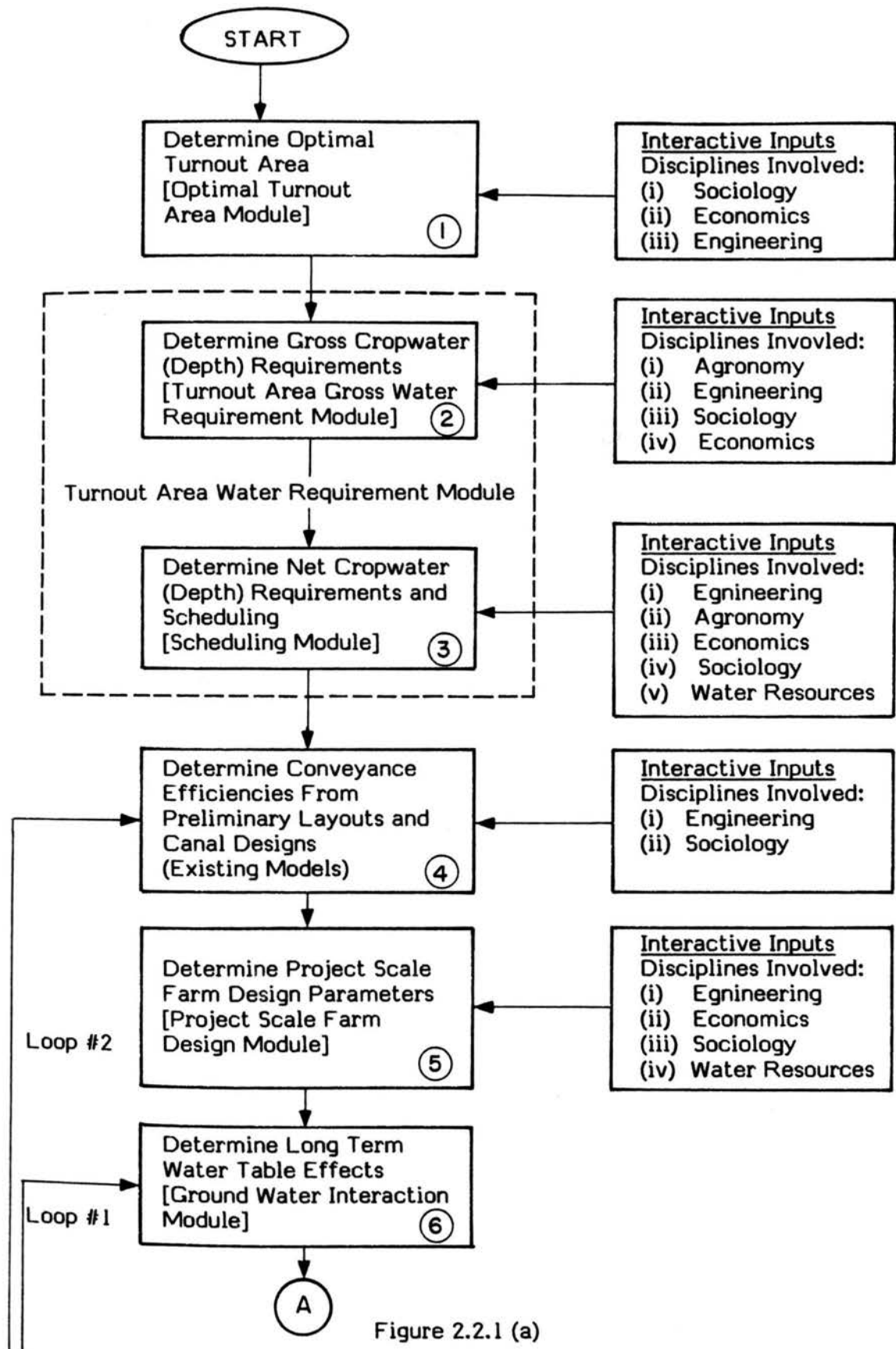

Figure 2.2.1 (a)

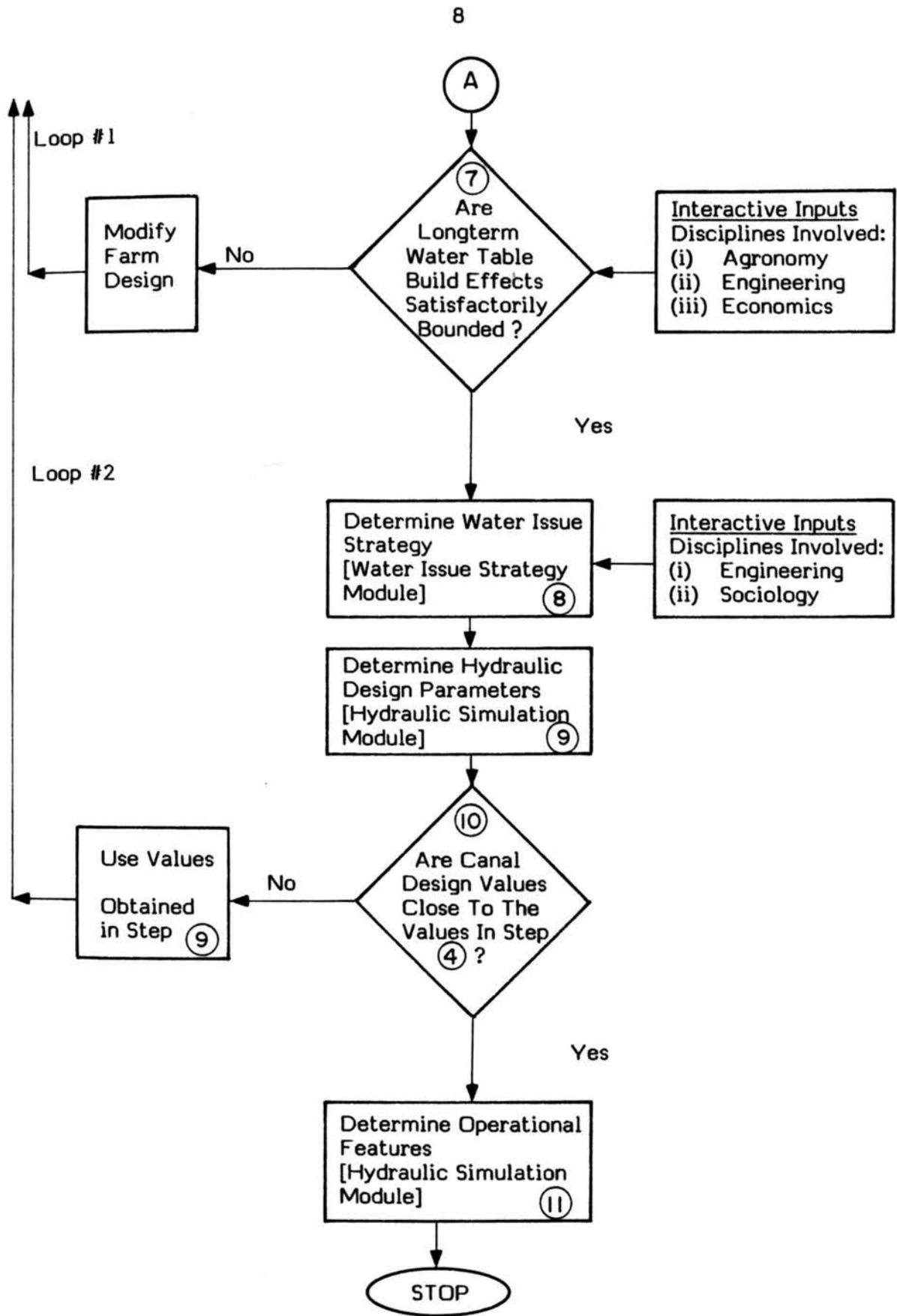

Figure 2.2.1 (b)

CHAPTER 3

OPTIMAL TURNOUT AREA MODULE

3.1 INTRODUCTION

Turnouts are control points in irrigation conveyance systems. An irrigation project model could be conveniently divided into a macro model and a micro model about these control points. Decision variables for the macro model are the flow rate, the time of flow and the frequency of flow at the turnouts. These become the inputs to the micro model of the farm systems (served by the turnouts). Turnout areas may be a part or whole of a system managed mostly by farmer groups rather than the bureaucracy. Farmers within a turnout area interact amongst themselves either as groups or as individuals socially and in their irrigation activities. If there is rotation of water issues within the turnout area their interaction becomes very pronounced. If the system is of continuous delivery type, inequity in the waterflow to the individual fields brings about conflicts amongst the farmers. In systems of rotational delivery type, inequities in the sequence, frequency, duration of flow and the flow rates bring about conflicts amongst the farmers. Conflicts could arise despite irrigation equity.

In many instances the nature of the construction of the field canals from the turnout and the nature of the position of the field in relation to the water surface elevation in the canal give rise to inequities in the distribution of water. A clinical approach is often necessary to rectify such problems and this requires a considerable amount of human and financial resources. Water

management programs have often attempted to solve such problems of physical nature. In this sense, in all those irrigation projects where the resources of the farmers are meager, a water management improvement program subsequent to their construction becomes essential. Such attempts to rectify problems due to physical systems would reduce the conflicts to a considerable degree in continuous flow systems. In rotational systems conflicts may still occur due to inequities in duration and frequency of water flow which depend on the system operators. An important point to note is that conflicts regarding water receipts amongst farmers within a turnout area need not necessarily lead to reduced farm production. Conflict causing factors, thus, tend to be stochastic in nature both in temporal and spatial senses though they may have deterministic components.

From the above point of view the number of conflicts are expected to be lower when lesser number of farmers share a single turnout. The concept of canal system being an integrative mechanism breaks down if the farmers realize that water receipts are not dependable and they have no control even as a group over the dependability of water supply - a case that is more likely to arise if too many farmers share a single turnout. Turnouts require to be constructed and managed and hence the resource constraints tend to minimize the number of turnouts in the whole system.

For new canal irrigation projects we should envision two basic situations. One is that of already existing farms being provided with irrigation water and the other is that of new farms being opened up with a settlement scheme. Unequal individual farm sizes may occur in the former case and in the latter one deals with mostly equal farm sizes. In the case of equal farm sizes, providing turnouts on the basis of area or on the basis of number of individual farms served by the turnout would be the same provided that the turnout area

contains an integral multiple of the individual farm sizes. Even in the case of unequal farm sizes it may be expedient to provide turnouts on the basis of area than on the basis of number of farmers.

In such a situation in the design of a new canal irrigation project in a matrix of sociological, economical and engineering contexts, the issue of the optimal turnout areas is posed. Quantitatively, in the case of equal farm sizes, this problem could be translated into finding the optimum number of farms served by each turnout. In the case of unequal farm sizes the problem posed would again be the optimum (maximum) number of allowable farms served by each turnout.

In its true aspect, this problem needs an interdisciplinary approach for solution. In recent times there has been a considerable flux of literature related to the sociology of irrigation areas. While necessary engineering and economic criteria for the design of turnouts could be more easily formulated the sociological criteria appear to be critical and very elusive. It is the objective of this module is to construct a model for the determination of the optimal turnout area that would be managerially ideal.

3.2 LITERATURE REVIEW

3.2.1 Generalities

The problem of an optimal turnout area as mentioned previously is a complex issue and has not been specifically dealt with in detail. Since farmers' cooperation is needed within a turnout area, the relevant questions for the sociology discipline would be the optimum number of farmers who may be allowed to share a single turnout. Wade (1976) mentions:

".....Much seems to depend on the size of the group which needs to cooperate: a group of 10 or possibly 15 people who depend on a single water source seems to be able to perform such tasks relatively successfully....."

Coward (1977) quotes a study by Taillard on a Laotian system:

".....Lao Society is founded on reciprocal solidarity bonds connecting the members of a group; in order for these bonds to function satisfactorily the group must not have more than 70 or 80 members....."

Such assessments unless qualified by a more thorough analysis would not be optimum. However, conflicts and cooperation amongst farmers served by canal water have been studied by many sociologists. There is a vast body of literature that deals with these issues and most of them are site specific case studies in static settings. It is sufficient to review a few here. The references in the reviewed literature would give the fuller spectrum of the studies made.

3.2.2 Sociological Studies

Dynamics of conflict or cooperation over water in canal irrigation is describable only in a certain parametric sense. Some hitherto identified parameters are "relative proximity" to the turnout of any given farmer, kinship or brotherhood relationship of the farmers, power/influence wielded by them, centrality and equality of such power/influence in a given water course, size, distribution of farms in the area, and total number of farms in the water course. Available literature would be reviewed using frequent use of these parameters.

Pasternack (1968) studied a system in Taiwan that consisted of a canal system augmented by local pumps. He identified that the relative location of fields with respect to the water source is an important factor. Kinship is irrelevant to irrigation in that still conflicts could occur should there be inequity in water receipts. Pasternack's (1968) hypothesis that when access to irrigation water is equalized in terms of time and quantity there would be fewer conflicts over water is only well known now.

VanderMeer (1971) studied water thievery again in a system in Taiwan. An important finding was that the effect of the degree of control of main system operators is inversely related to the cooperative spirit. Thus, a factor that should go into the analysis is the amount of the control the main system operators have on the water issues. This factor however, can be included in the power/influence parameter of Lowdermilk et.al. (1978). VanderMeer (1971) observed that the water scarcity reduced water thefts since the farmers become more alert during such times. Duration of the flow of water in the distributing canal has an influence on the design and so do the methods of water control from a designer's point of view. The following general rules need be adhered to:

- (1) Reduce inequities of water issues amongst the farmers;
- (2) Reduce the duration of flow along reaches where the possibilities of thievery are high;
- (3) Design in such a way as to induce cooperation to obtain water and;
- (4) Reduce the number of farmers served by a canal outlet as far as possible to reduce conflicts.

Of these rules, (1), (2) and (4) are already familiar to us. Difficulty lies in (3). VanderMeer points out that cooperation depends on the degree of spiritedness and the tradition of cooperation amongst farmers - a factor that we should consider in designing. Such an attitude and tradition, we should be careful to note, might have evolved due to the nature of the physical system and, the water control methods imposed on to the farmers and other climatic and social factors. However, in design, it is preferable to allow explicitly for

such a factor for the degree of spiritedness and tradition of cooperation. A system design that also lays down the operational procedure may have to incorporate the idea of guarding the water issue. VanderMeer (1971) states that careful guarding would result in lesser thefts and fewer conflicts.

Hunt and Hunt (1976) described in broad terms, the social organization in irrigation systems. However, they did not analyze the basic mechanisms of cooperation and conflict, the emphasis being again based on case studies. The external-local systems interaction described by them is more powerfully and accurately described by Lowdermilk et.al. (1978) in terms of power/influence. The tendency of Lowdermilk et.al. (1978c) was to look from an individual farmer's point of view in contrast to the attempt by Hunts (1976) to strike it middle-between the farmers and the external social environmental system. In design the approach would be to minimize conflicts and to bring in a new social order in sharing the water than to let the system achieve equilibrium on its own with loss of production. In this sense, linkages and role embeddedness (as given by Hunts (1976)) cannot be factors of design though their final evolution without affecting the optimal production states may be anticipated.

Significant contributions to the study of farmer conflicts have come from the work of Lowdermilk et.al. (1978a, 1978b, 1978c), Freeman et.al. (1978a, 1978b), Mirza and Merrey (1979), Merrey (1979) and Early et.al. (1978). These contributions have arisen in an interdisciplinary mode and are attempts at factor analyses than mere synchronic descriptions of the systems. The ideas embodied in these papers have come about after extensive field research in Pakistan by an interdisciplinary team (Clyma et.al. 1977) of professional students (a synonym for professionals who are students) from Colorado State University and would be referred to here as CSU studies. Despite attempts at generalization of these studies one could still find elements that are peculiar

to the Pakistani systems. In abstracting very general factors from these studies, therefore, we should exercise caution.

A definition of conflict in the social sense is that it is a cleavage in the social network - a cleavage that results in nonfunctioning or reluctantly functioning (in the social sense) of a particular element where smooth functioning is expected. The magnitude of these conflicts are given two qualitative descriptors - polarizing and nonpolarizing. Colorado State University studies indicated that conflicts once counted should not be ignored on the basis of their magnitude. The major findings of the CSU researchers as regards the following factors that affect the conflicts are described below.

(i) Kinship or Brotherhood Relationship.

This factor may not exist in some systems. (For example, settlement schemes.) Another situation that has to be studied is the existence of a formal irrigation association in an area that already has a certain web of kinship or brotherhood relationship. Pasternak (1968) observed in such a situation that kinship is irrelevant to irrigation. CSU studies reveal that a high percentage (about 80) of farmers in the area studied where there were no irrigation associations, were bounded by the brotherhood ties. Along these lines for design purposes, we may consider for conflict causing factors two parameters - the percentages of different kinships in a turnout area for areas without irrigation associations and a measure of power of an irrigation association over the individual farmer, depending on the system. Different kinships would indicate a potential for conflict. CSU studies indicate that in single brotherhood areas, (in studies of watercourses in Pakistan), there was a tendency for more cooperation in watercourse maintenance. Differences in castes may have to be treated like differences in kinship/brotherhood relationship when only different caste groups share a turnout area.

(ii) Power/Influence Distribution

This factor was identified in the context of watercourse cleaning and settling watercourse disputes and would be useful in a design process. Two kinds of power/influence have been identified. One is that of internal nature - within village and kinship or brotherhood relationship - and the other is that of external nature - the power/influence farmers have with governmental officers or system officials. These concepts may be meaningless in certain societies where everybody is treated very equally as far as system rules are concerned.

Colorado State University studies reveal that a very high percentage of the farmers have no real power and influence both within their community (about 70%) and with government officials (about 80%). A notable finding that is relevant here is that land (farmed or owned) size is weakly correlated to power/influence and being close to the turnout does not guarantee higher power. Colorado State University studies came out with two parameters for this distribution of power/influence that are important. These parameters are centrality and equality of power/influence in a watercourse. It is preferable to briefly describe them here.

The measure of centrality of power is given in relation to the potentially high score for power/influence in a watercourse area. This index will reveal what percentage of farmers have 90+, 80+, etc. of the potentially highest score in a watercourse area. If the centrality index is high, (say the 80+ level), it indicates that a high percentage of farmers have a high influence/power.

The measure of equality of power gives the extent to which power is distributed equally among farmers in a watercourse and is calculated by finding the fraction of the farmers who would account for 50% of the total

power/influence scores when counted from the highest score. The lower the score the more unequal is the power distribution and vice versa.

Colorado State University studies in Pakistan tend to show that there is more cooperation on those watercourses where there is a high centrality and high equality of power. Such watercourses have been termed pluralist as opposed to elitist watercourses where there would be low centrality and low equality of power. The relevance of these indices of centrality and of equality of power for the design of irrigation systems where the farms are already existing can be seen. In new systems of the settlement type, we can only deal with the expected values of these indices which may be obtained from an existing system.

The sociological input could come in assessing levels of centrality and equality that are desirable in a watercourse or a turnout area and in finding ways to increase the values of these indices. CSU studies in Pakistan's Punjab reveal that 70+ level for the indication of high centrality of power. It can be seen from the CSU studies (Lowdermilk et.al. (1978), page 222) that equality and centrality do not depend on the number of farmers in the watercourse. This may be due to the methodology applied to collect power/influence data (Freeman et.al., (1978)). A 25 percent sample farmers were chosen in a watercourse area and were asked about the rest of the farmers in the area as to their influence. As the number of farmers increases, this assessment may tend to be inexact. In certain watercourses the number of farmers has been of the order of 60 (Lowdermilk et.al., 1978, page 222). Whereas the centrality and equality parameters would indicate the conflict resolution capabilities of the system, the number of farmers would indicate the degree of potential for conflict. This has also been indicated by Bromley et.al. (1980). They (Bromley et.al.) identified location of a farmer in relation to the water source and the

number of farmers preceding them in the sense of water flow as a factor that one should study for water reform.

Two more sociological factors worth mentioning here are previous conflicts and previous cooperation (Mirza and Merrey, (1979)). The latter had also been mentioned by VanderMeer (1971). An index for each of these factors would be useful in design. These indices may not be necessary in a new project with a settlement scheme. In an area that already has farms that are to be provided with irrigation facilities average indices may have to be used.

In summary the following are the sociological factors that one should study for the problem of optimal turnout areas:

- (1) Number of farmers served by the turnout;
- (2) Possible or existing Kinship/Brotherhood relationship/patterns in the absence of irrigation associations;
- (3) Possible or existing power/influence distribution;
 - a) centrality of power in the turnout area and,
 - b) equality of power in the turnout area,
- (4) Degree of spiritedness and tradition of cooperation and
- (5) Degree of previous conflict.

It may be seen that factor (4) finally describes farmer behavior in the turnout areas. Factors (2), (3) and (5) influence factor (4). The modeling of farmer behavior in turnout areas, which is given subsequently, incorporates factors (1) and (4).

3.2.3 Engineering Studies

It is now relevant to see the types of engineering analyses that have been undertaken to study this problem. In a recent paper Tabbal and Bhuiyan (1982) addressed the problem of optimal turnout areas as applied to the diversion irrigation systems in the Philippines. The context of their optimality however needs mention here. The terminal systems they studied consisted of a turnout which was supposed to release water continuously for the turnout area consisting of 5 sub-areas (or rotation areas) that were designed to get water in five day rotations and a system of ditches from the turnout. However, the main laterals that serve the turnouts, due to low flow situations in the feeder stream carried water discontinuously during the dry seasons. This resulted in the practice of continuous delivery whenever water was available in the sub-areas in contrast to the theory of rotational delivery. Farmers also constructed unregulated extra turnouts to facilitate water delivery from the lateral to the Main Farm Ditches (MFD) (Figure 3.2.1) under constraining conditions. Construction of extra turnouts indicates the failure of the turnout-farm ditches systems at the terminal level built by the bureaucracy and implies that only a certain optimal area that can be effectively served by a turnout. Orientation of the MFD also has been found a critical factor that could affect the extent of area manageable with a given turnout flow.

A basic assumption of Tabbal and Bhuiyan (1982) is that in the process of fixing the optimal turnout area, the farmer practices related to irrigation (i.e. water sharing, watercourse cleaning, etc.) do not change. That is, the sociological factors would not change when sub areal delineations are changed. The validity of this assumption has to be sociologically verified.

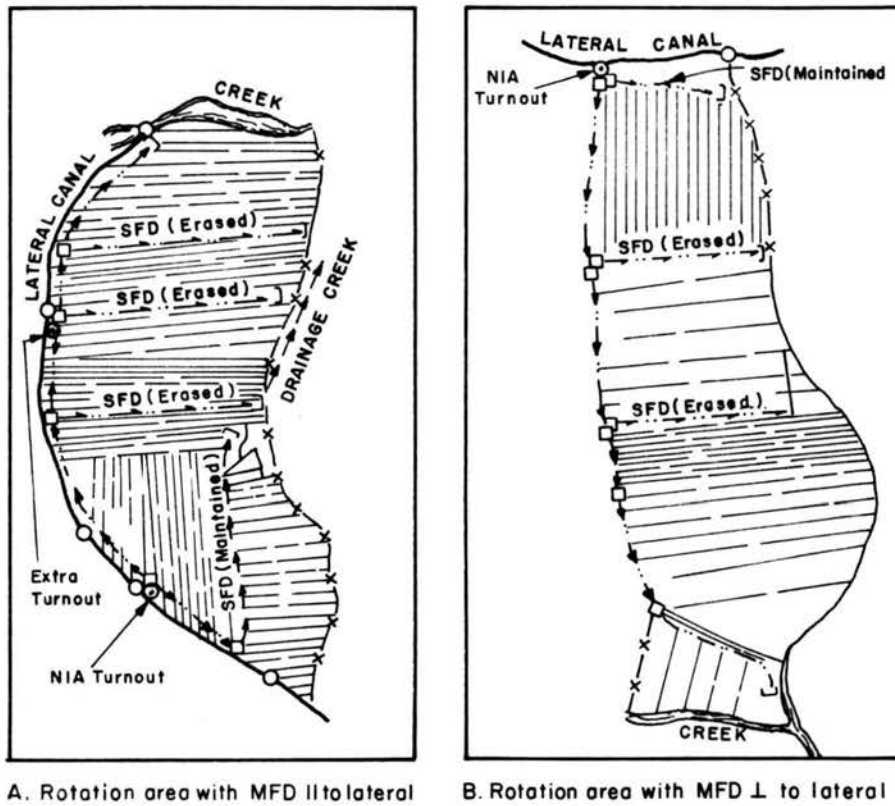

FIGURE 3.2.1 Parallel and Perpendicular MFD
(After Tabbal and Bhuiyan (1982))

The following are the physical parameters that have been identified by Tabbal and Bhuiyan (ibid) as those which affect this size of turnout area:

- (i) Water Flow Rate at the Turnout - Q (litres/sec/ha)

The average daily flow rate during the whole irrigation period.

- (ii) Fluctuation of Q

- a) Percent of Irrigation Period with Zero flows - IZ

This is defined as:

$IZ = (\text{No. of days during the irrigation period that waterflow at the turnout is zero}) / (\text{Total number of days of the irrigation period})$.

- b) Variation of waterflow rate - CV

Definition is as follows:

$CV = (\text{Standard deviation of daily waterflow rate}) / (\text{Average daily waterflow rate})$.

- (iii) Average Farm Size in the Turnout Area - F_s (ha)

The definition of F_s is:

$F_s = (\text{Turnout Service Area (ha)}) / (\text{Number of farmers in the area})$.

- (iv) Farm Ditch Density - FD (m/ha)

FD is given by:

$FD = \frac{\text{Total length of farm ditches}}{\text{Turnout Service area}}$

- (v) Main Farm Ditch (MFD) Gradient - G

$G = (\text{Summation of fall in elevation per 20 m of MFD length}) / (\text{Total effective MFD length})$.

- (vi) General Land Slope - S

$S = (\text{Difference in elevation between the fields near the MFD and drainage canal or creek}) / (\text{Total distance between the fields})$.

- (vii) Slope Factor - SF

$$SF = \frac{\text{Effective MFD length (m)}}{\text{Average width of rotation area}}$$

Average width of rotation area is equal to the average length of farm lots.

- (viii) Percent of farms with direct access to MFD - AC

The definition for AC is as follows:

$$AC = \frac{\text{Number of farms with direct access to MFD Nos.}}{\text{Total Number of Farms.}}$$

- (ix) The orientation factor of the MFD with respect to the main supply canal - Or

MFD's are classified either as parallel or perpendicular to the supplying lateral.

Or = 0 when MFD is parallel to the supply canal and

Or = 1 when MFD is perpendicular to the supply canal.

Of these factors, AC and to some extent SF also would indicate the orientation of the MFD.

From the data collected in the Camiling River Irrigation System (Cam RIS) a regression analysis was made using initially a functional relationship of the form.

$$AR = f(Q, F_s, SF, Or, IZ, G, S, FD) \quad (3.2.1)$$

where AR is the turnout area (in ha). The final analysis revealed that the equation:

$$AR = 22.32 + .33 Q + 2.70 F_s + 1.08 SF - 1.19 SF^2 + .96 (Q SF) - .1.95 S + 26.93 Or + .42 IZ - .20 (SF \times IZ) \quad (3.2.2)$$

explained 90% of the variation. The farm ditch density FD is not included in the equation since this does not significantly affect the turnout area size. The findings of the Trilateral Commission (as quoted by Wade and Chambers (1980)) that suggested a density of 50m/ha as the dividing line between adequately and inadequately irrigated areas. The value of $FD = 53.50$ m/ha for the case of parallel MFD system reported by Tabbal and Bhuiyan (1982) is close to this value. It was also found out that the orientation factor Or contributed significantly to the value of Ar . For the average situation in Cam RIS:

$$Q = 1.5 \text{ litres/sec/ha,}$$

$$S = 0.87\% \text{ and}$$

$$Fs = .87 \text{ ha/farm,}$$

Tabbal and Bhuiyan determined from Equation (3.2.2) that the optimal turnout areas to be 20 (ha) and 47 (ha) for $Or = 0$ and 1 respectively. This meant that the optimal number of farmers in a turnout area to be 23 for the case of parallel MFD ($Or = 0$) and 54 for the case of perpendicular MFD ($Or = 1$).

It is now relevant to analyze the dominant factors, SF, Or and IZ as to their generality. The orientation of the main farm ditch in this case had a significant influence because in the parallel case farmers could resort to extra turnouts. Tabbal and Bhuiyan (1982) mention, in the case of MFD being perpendicular to lateral or supply canal:

".....farmers are obliged to collectively maintain their farm ditches in order to facilitate the conveyance and distribution of water to their farms...."

The IZ factor accounts for water availability and also affects farmer behavior.

The above are some physical factors that are causative of individual farmer behavior. Existing or expected disparities in the physical systems such as fields being above the water surface in the canal, etc., can also be included

in the list of causative factors. The sociological factors play an important role in the analysis of conflict resolution and cooperation which are conducive to efficient farm production.

The construction of a model that would lead to the determination of the optimal turnout area also involves a good approximation of the mode of interaction of the factors reviewed above. The basic tools necessary for such a model building could come from the discipline of applied mathematics. The relevant mathematical approaches will be reviewed as we proceed to build the necessary model.

3.3 A PROBABILISTIC SYSTEMS APPROACH FOR TURNOUT AREA INTERACTIONS

3.3.1 Generalities

In the previous chapter a survey of the factors that affect the farmers' interactions within a turnout area was made. The sociological and the physical factors that have been identified as dominant are site specific and have to be interdisciplinarily studied when one proceeds to determine the size of optimal turnout area or the optimal number of farmers who may be allowed to share a single turnout. The definition of optimality has to be defined in a manner that transcends the confines of different disciplines and in a manner in which a balance is struck between the farmer's benefits in his individual and collective states. For instance, an economic criterion per se may give too crowded a turnout area. Conflicts may be to such a degree and magnitude that only a relatively small proportion of the farmers in the turnout area may be successfully receiving water for irrigation. Since our concern is that an individual farmer receive water for irrigation, the optimality criterion is related more specifically to water receipts than to purely an economic criterion.

The problem of optimal turnout area as has already been observed involves both physical and social factors. Thus, the tools developed by mathematical sociologists (Coleman (1973)) and systems engineers (Rau (1970)) are relevant for analysis. However, when a mathematical sociology construct is used, the physical factors also should be taken into account and when a systems engineering approach is taken, the sociological factors should be used. As is seen subsequently, parameters that may be combinations of both physical and sociological factors need evaluation. It should be emphasized again that this evaluation is an interdisciplinary task.

3.3.2 A Mathematical Sociology Approach

Coleman (1973) identifies two types of basic theories that can be used to analyze collective action. The first type is called the causal processes theory, and the second, purposive action theory. In causal theories the actions of a group member is an event and the analysis deals only with a pair of descriptors as cause and event outcome. In purposive action theories the actor is supposed to look beyond the outcome of the event, weigh the consequence of the outcome to him/her and adjust his/her actions. It is important to mention here a basic aspect of these studies. In sociological processes the variation of the factors with time are important considerations. This aspect complicates the analyses and in relation to the question at hand, we may have to resort to an equilibrium or an evolved model rather than a complete dynamic model. As was observed previously, both the physical and sociological factors should be incorporated appropriately.

Causal Process Models For Turnout Area Interactions

Causal theory uses probability models to account for the distribution of different actions of different members in the group studied. A member's action could be due to his or her being in a particular state (mental) which

again may not be deterministic. A popular and basic model for causal processes is the Bernoulli Trials Model (BTM) in which a certain number of independent and identical trials take place with each trial giving an outcome called "success" and another called "failure". Irrigation events in a turnout area can be modelled regarding the event of a farmer obtaining irrigation water in "sufficient" amounts as "success" and the event of him/her obtaining "insufficient" water as "failure". With such notions of outcomes of an irrigation event, and assuming independence we would be able to compute the following probabilities:

- (i) Exactly r successes in n trials and
- (ii) r or more successes in n trials.

The probability of success, of course, depends on the states of the ditch system and other factors amongst which sociological factors are major. The use of the basic BTM may not be tenable since the assumption of independence may not be valid. The methods by which dependence could be introduced into the basic model is discussed subsequently. The different methods by which the basic BTM can be extended for the turnout area interactions (Coleman (1973)) is given below.

- (i) Probability Of An Outcome As A Function Of Factors. (See path 3 in Figure 3.3.1)

The basic BTM gives the probability p_r , of r successes in n independent trials, as:

$$p_r = \binom{n}{r} p^r (1-p)^{n-r} \quad (3.3.1)$$

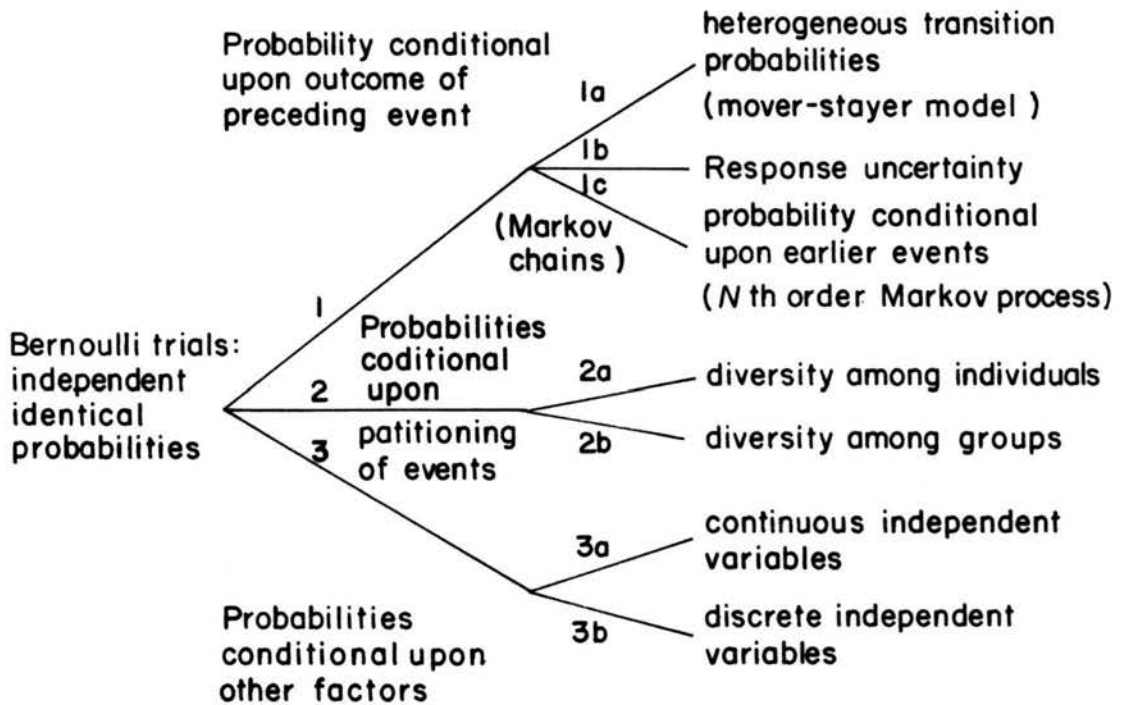

FIGURE 3.3.1 - Basic Causal Processes Models (After Coleman (1973))

where p is the probability of success in a single trail. Using 3.3.1, the probability of m or more success in n trials is given by:

$$p(m) = \sum_{r=m}^n \binom{n}{r} p^r (1-p)^{n-r} \quad (3.3.2)$$

These equations 3.3.1 and 3.3.2 can be applied to the collective irrigation events by farmers only for the cases where the farmers have uniformly same probability of success independent of each other. Such cases would arise only when there is a high degree of cooperation amongst the farmers and when the physical factors, both internal and external uniformly affect the probability of success of all the farmers. The probability, p , of success of any given farmer is associated in this method in the form (Coleman (1973)).

$$p = a + \sum_{i=1}^{n_f} b_i x_i \quad (3.3.3)$$

where a and b_i are coefficients, x_i the affecting factors and n_f is the total number of factors. The x_i could be discrete or continuous variables. For the present case the following factors may be considered as affecting the probability p (of success) of an individual farmer at a given irrigation.

- $x_1 =$ IZ - Fraction of irrigation period with zero flows,
- $x_2 =$ CV - Variation of water flow rate,
- $x_3 =$ Or - Orientation factor,
- $x_4 =$ A factor for water surface elevation in the turnout area ditch being lower than the fields,
- $x_5 =$ A factor for faulty outlet construction and
- $x_6 =$ A factor for the state of repair of the ditch system.

Caution should be exercised in using Equation 3.3.3 for regressing p with x_1 . Since, the success of an irrigation event essentially is conditional upon the availability of water the appropriate equation to use is:

$$p = (a + \sum_{i=2}^7 b_i x_i) (1 - x_1) \quad (3.3.4)$$

Since x_1 is the probability of the availability of water, the factor within the parameters would give the probability of success given the condition of 100% water availability. Once this probability p is assessed, it is possible to evaluate the probabilities for any required fraction of success within the group of n using Equation 3.3.2. In this case, the expected number of successes in any given turnout area is np and the expected fraction of farmers successfully obtaining water is, p , which does not depend on the number of farmers, n , in the turnout area. It can be seen from the binomial tables that the probability $p(m)$ decreases as n increases when the required fraction of successes is more than p . That is, if one expects more fractional successes from the group than the system performs, on an average, one should minimize the number of farmers in the group. In such a situation it would be preferable to use other criteria such as economic criteria for the determination of optimal turnout area. The economic analysis will be given separately.

(ii) BTM With A Given Distribution For p . (See Path 2 in Figure 3.3.1)

Irrigation within a turnout area is an inter-dependent event and actions of a farmer are likely, in general, to affect another. The assumption of a uniform probability for the event of a farmer successfully obtaining irrigation water in the general case will not be valid.

When a farmer receives water, the following two responses are possible:

- i) He/She hinders the flow to the next farmer in some way or
- ii) He/She does not do so.

Uncertainties in the flow of water, the nature of the ditch and field systems are the main causative physical factors. While the causative sociological and psychological factors are yet to be dealt with fully at least in the reviewed literature, it should be recognized that the above responses are likely to be different from person to person. It should also be noted that such diversity amongst individuals need not be constant with respect to him or herself. If we specifically deal with the attitude of a farmer towards not hindering the flow to the next farmer, the measurement of such an attitude amongst a group of farmers is possible by many methods. An important one of those methods is the so-called Latent Structure Analysis (LSA) of Lazarsfeld. (Lazarsfeld (1954)). LSA belongs to a broader category called the response approach (Torgenson (1958)). In this approach, variability of reactions to stimuli is associated with both the variation in the subjects and in the stimuli. Through LSA we would be able to arrive at the probability of a farmer hindering the next to a specified degree. This again would lead us to the fact that the expected proportion of successes in the group to be the expected value of such probability.

If we assume that the physical systems associated do not give rise to problems and that the hindering of one farmer to another of the waterflow is the only problem, then we could study the heterogeneity in responses by the farmers in another way by a method given by Coleman (1964), which also has common elements with the LSA of Lazarsfeld. As has been indicated already the individual has a number of elements within (him or herself), a portion of

which will lead to a particular response state and the rest to another state. If there are m_1 elements in state 1 and m_2 elements in state 2 the probability of an individual responding positively to state 1 is given by:

$$p_1 = \left(\frac{m_1}{m_1 + m_2} \right) \quad (3.3.5)$$

In general, as has been observed already, an individual has variability within him or herself (i.e. m_1 and $m_2 > 0$) and different individuals have different m_1 and m_2 . Thus, in a group p_1 would have a density distribution, say $f(p_1)$. We will now proceed to find the m successes in n trials in each of which we have probability of success coming from an identified distribution $f(p_1)$.

The mass function of m success in n trials given that the probability of success at each trial is p_1 , is given by:

$$g(m/p_1) = \binom{n}{m} p_1^m (1-p_1)^{n-m} \quad (3.3.6)$$

Assuming a continuous distribution $f(p_1)$ the mass function for m , $g(m)$, is given by (Woodroffe, (1975))

$$g(m) = \int_0^1 \binom{n}{m} p_1^m (1-p_1)^{n-m} f(p_1) dp_1 \quad (3.3.7)$$

Now $E(m)$ is given by,

$$\begin{aligned} E(m) &= \sum_{m=0}^n mg(m) \\ &= \sum_{m=0}^n \int_0^1 m \binom{n}{m} p_1^m (1-p_1)^{n-m} f(p_1) dp_1 \\ &= \int_0^1 \sum_{m=0}^n m \binom{n}{m} p_1^m (1-p_1)^{n-m} f(p_1) db_1 \\ &= n \int_0^1 p_1 f(p_1) dp_1 = n \bar{p}_1 \end{aligned} \quad (3.3.8)$$

Thus the expected proportion of successes is p_1 , which does not depend on the number of trials.

A suitable distribution for p_1 would be the beta distribution with parameters α and β (See Woodroffe, 1975). In this case $g(m)$ would be given by:

$$g(m) = \binom{n}{m} \frac{\Gamma(\alpha + \beta)}{\Gamma(\alpha)\Gamma(\beta)} \frac{\Gamma(\alpha + m)\Gamma(n + \beta - m)}{\Gamma(\alpha + \beta + n)} \quad (3.3.9)$$

The results are given in Appendix 3.1 for the following cases:

- i) $\alpha = 3$ and $\beta = 2$, and
- ii) $\alpha = 5$ and $\beta = 3$.

Here again for these cases one can see that the probability decreases as n increases. It should be noted that the expected value for the beta distribution with parameters α and β is given by:

$$\bar{p}_1 = \mu = \frac{\alpha}{\alpha + \beta} \quad (3.3.10)$$

The above methodology may be suitable for the case of physical factors not dominating and when only the attitudes are a problem. If the physical factors are to be included, a proper distribution for p_1 has to be identified.

(iii) BTM With Fixed Reduced Probabilities.

In the above approach, independence of irrigation events was assumed with a given distribution of the probability of a farmer successfully obtaining water. Most of the turnout area (TA) ditch systems are of dendritic type. Be the system of rotational type (within the TA) or be it of continuous type, the probability of a farmer successfully obtaining water reduces as one proceeds towards the tail end of a ditch system. As has been briefly mentioned before,

physical factors such as canal seepage, erosion, sedimentation and poor quality of ditch construction and social factors such as a farmer hindering flow of water to the next farmer contribute towards the probability of water availability as one moves away from the turnout towards the end. Assuming again independence of irrigation events by different farmers we could still model the turnout irrigation events assigning lower probabilities of success as one moves from the turnout towards the end. Firstly, let us develop a formula for exactly r successes in n trials with the probability of success in the k^{th} trial being p_k using generating functions (Woodroffe, (1975)).

Let x_k be a random variable taking the value of 0 or 1.

Let $p_r(x_k = 1) = p_k$ and

$$P_r(x_k = 0) = 1 - p_k = q_k$$

The generating function $A(t)$ for x_k is given by:

$$A(t) = \sum_{i=0}^{\infty} a_i t^i \quad (3.3.11)$$

where,

$$a_i = P_r(x_k = i) \quad (3.3.12)$$

Thus, for the present case:

$$A(t) = q_k + p_k t \quad (3.3.13)$$

Also,

$$E(t)^{x_k} = A(t) \quad (3.3.14)$$

Let the required generating function (for the BTM with unequal probabilities of success) be $B(t)$.

Then,

$$B(t) = E(t^X) = \sum_{i=0}^{\infty} b_i t^i, \quad (3.3.15)$$

where,

$$b_i = P_r(x=i).$$

But,

$$E(t^X) = \prod_{k=1}^n E(t^{x_k}) \quad (3.3.16)$$

Using Equation 3.13 in this,

$$E(t^X) = \prod_{k=1}^n (q_k + tp_k) \quad (3.3.17)$$

Thus,

$$P_r(x=r) = b_r = \text{Coefficient of } t^r \text{ in the expansion of:}$$

$$\prod_{k=1}^n (q_k + tp_k)$$

Now,

$$b_r = (p_1 p_2 p_3 \dots p_n) b_r' \quad (3.3.18)$$

where b_r' is the coefficient of t^r in

$$\prod_{k=1}^n \left(\frac{q_k}{p_k} + t \right) \quad (3.3.19)$$

Equation 3.3.18 can be written as:

$$b_r = \binom{n}{r} \sum_{\mu \in \Phi} \prod_{j \in \mu} \left(\frac{p_j}{q_j} \right) \quad (3.3.20)$$

where μ is an index set of $(n-r)$ elements, $\epsilon \Phi$, the set of $\binom{n}{r}$ combinations of the $(n-r)$ indices out of n indices (from 1, n). A computer code for this problem has been developed. Such a model would be useful if the different probabilities are evaluated extensively.

It was mentioned previously that as one moves from the turnout along the direction of flow, the probability of successfully obtaining irrigation water reduces. A simple model for this reduction could be stated as:

$$\frac{p_{i+1}}{p_i} = \xi \quad (3.3.21)$$

where p_i refers to the probability of success for the i^{th} farmer in a sequence of 1, 2, 3, ----- n and ξ a positive constant less than unity.

Noting that Equation 3.3.21 does not imply sequential dependence, Equation 3.3.20 may be used to evaluate the probability of r successes in n trials (b_r in Equation 3.3.20) once the initial probability, p_1 , and the ratio of successive probabilities, ξ , are given. The successive probabilities ratio, ξ , will depend on both physical factors such as the states of the ditch system and sociological factors such as the cooperation amongst farmers.

If Equation 3.3.21 holds, then,

$$p_k = p_1 \xi^{k-1} \quad (3.3.22)$$

In this case the average probability of success can be given as

$$\bar{p} = \frac{p_1}{n} \frac{(1 - \xi^n)}{(1 - \xi)} \quad (3.3.23)$$

The variance of the proportion of success in a group of n can also be easily computed to be:

$$V\left(\frac{N}{n}\right) = \frac{\xi(1 - \xi^n)(1 - \xi^{n-1})}{n^2(1 - \xi^2)} \quad (3.3.24)$$

where N is the number of success in n trials.

A manner in which this model could be used is to fix the required percentage of successes (say $x\%$) in a group of size, n , and to see how the probability (p) of obtaining this fraction or more successes varies with group size, n , and the successive probabilities ratio, ξ .

Figures 3.3.2 to 3.3.4 give the variations of the probability of obtaining more success than 70, 75 and 80% in the group, with ξ and n . It can be seen that as ξ increases the probability curve tends to indicate a maximum. The maximum value of n in the range $10 \leq n \leq 50$ is denoted as n_{\max} and its variation with ξ and the maximum required percentage of success is given in Table 3.3.1.

It could be seen that even though the maximum of the probabilities occur at certain values of group size, n , there is a range of n for which the probabilities are close to their maximum values for $\xi \geq 0.95$. These ranges are given in Table 3.3.2.

(iv) Conditional Methods - A 2x2 Markov Chain Model (MCM). (See Path 1, Figure 3.3.1)

There is an essential sequential dependence in obtaining water for irrigation by farmers in a dendritic ditch system within a turnout area. The problem was circumvented in the BTM developed in Method (iii) by assigning a constant ratio for the successive probabilities of success. Coleman (1973) suggests the use of markov process concepts for the extension of the basic BTM for causal theories. In this section we will analyze as to how the Markov Chain concepts could be used for turnout area interactions.

A process x_t is said to be first order Markovian if:

$$P_r \left[y \leq x_t \leq x \mid x_{t_1} = x_1, x_{t_2} = x_2, x_{t_3} = x_3 \dots x_{t_n} = x_n \right]$$

$$= P_r \left[y \leq x_t \leq x \mid x_{t_n} = x_n \right] \quad (3.3.25)$$

for

$$t_1 < t_2 < t_3 \dots t_n < t$$

This assumption is relevant for the case of a farmer obtaining water in a turnout area since any given farmer depends on the farmers ahead of him to obtain sufficient water. Since a higher order Markov process analysis would prove to be complicated, a first order MCM is developed. To begin with only a 2x2 MCM is developed in this approach and subsequently it will be indicated how a 4x4 MCM can be used.

Consider the following states in which a farmer may be in:

- 1) He is not successfully obtaining "sufficient" water for irrigation;
- 2) He is successfully obtaining "sufficient" water for irrigation.

TABLE 3.3.1

VALUE OF n AT WHICH MAXIMUM
PROBABILITY OF SUCCESS OCCURS

ξ	n_{MAX}		
	xps = 0.70	xps = 0.75	xps = 0.80
.90	10	10	10
.91	10	10	10
.92	10	10	10
.93	10	10	12
.94	10	10	12
.95	10	10	12
.96	14	14	12
.97	20	14	15
.98	20	18	16

TABLE 3.3.2

RANGES OF n_{MAX}

ξ	n_{MAX}		
	xps = 0.70	xps = 0.75	xps = 0.80
.95	10-14	10-12	10-12
.96	14-16	12-14	12-14
.97	14-20	14-18	12-16
.98	20-24	18-22	16-18

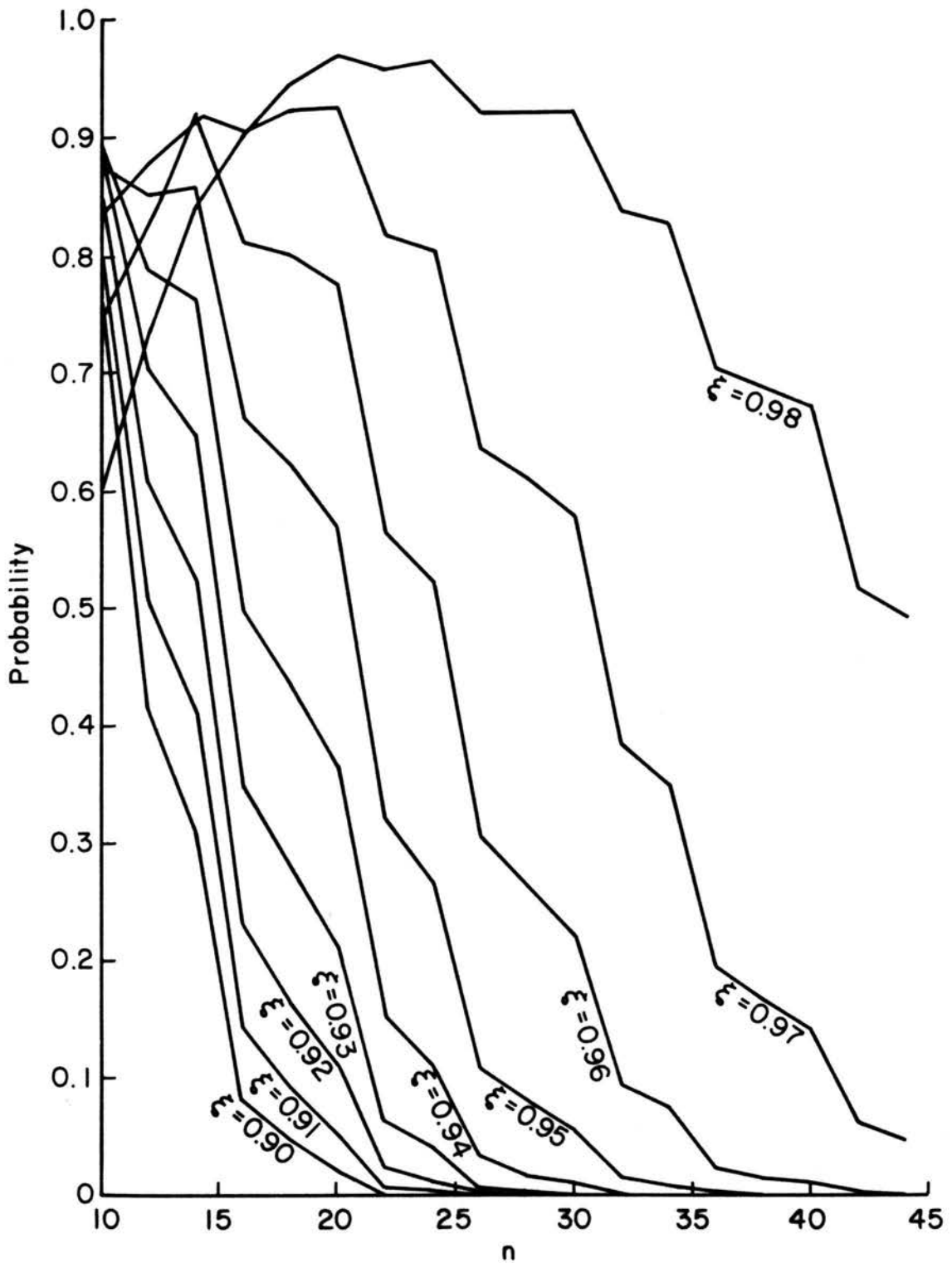

Fig. 3.3.2 Variation of Probability For Percentage (Or More)

Success = 0.70×100 With η and ξ

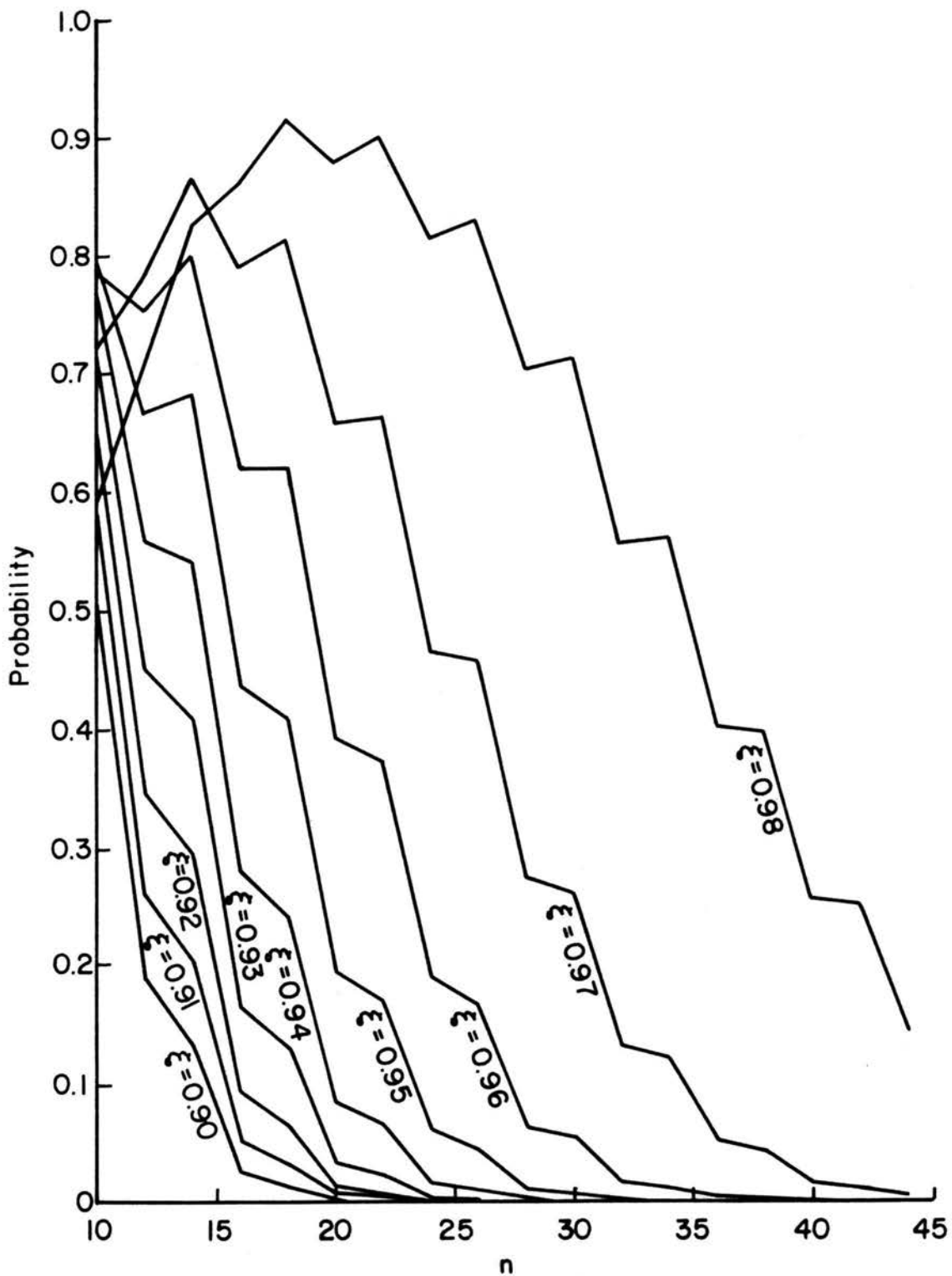

Fig. 3.3.3 Variation of Probability for Percentage

(Or More) Success = 0.75×100 with η and ξ

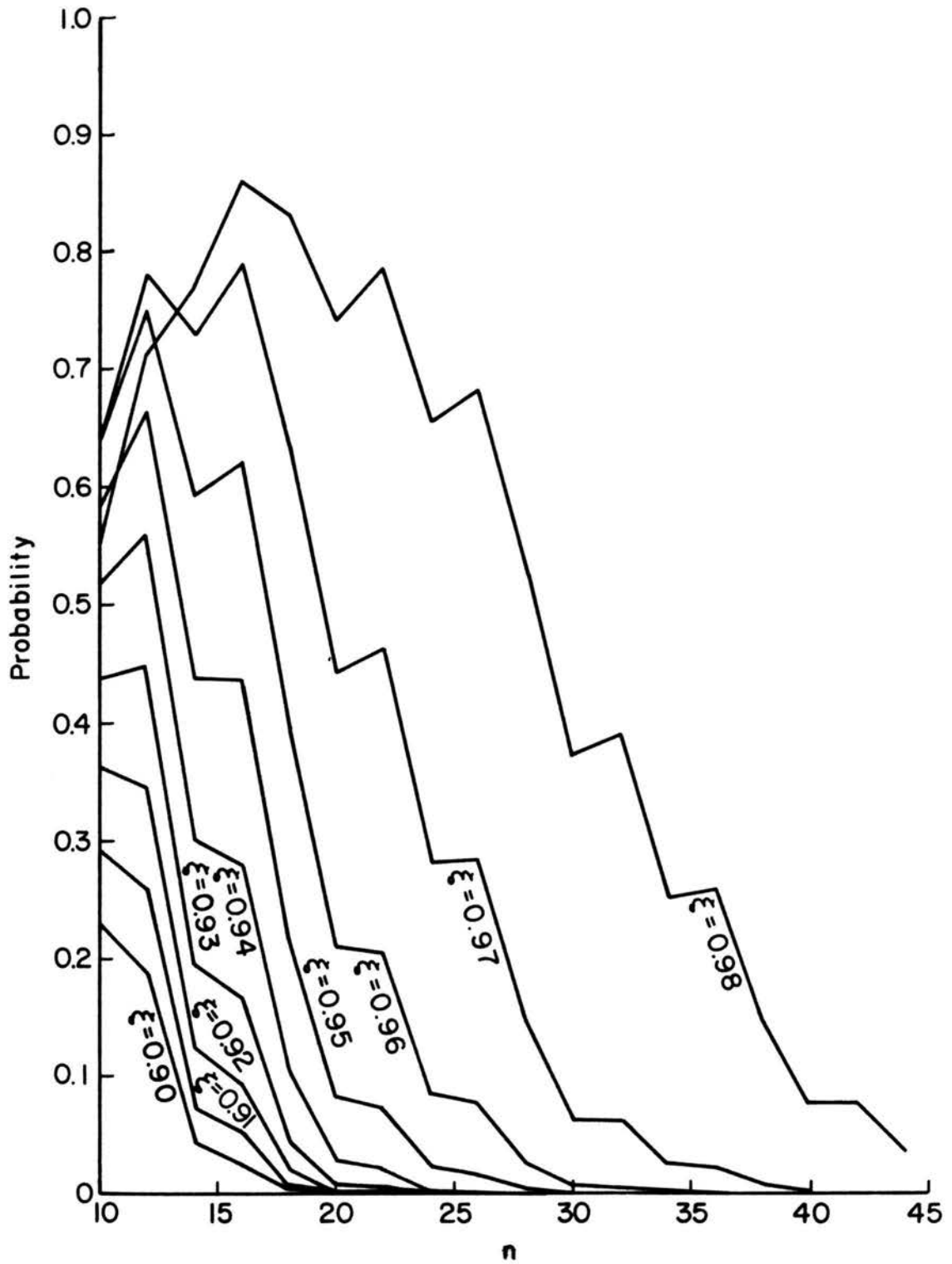

Fig. 3.3.4 Variation of Probability for Percentage

(Or More) Success = 0.80×100 with n and ξ

Now define the transition probability matrix:

$$[P]_{2 \times 2} = \begin{matrix} & \begin{matrix} 1 & 2 \end{matrix} \\ \begin{matrix} 1 \\ 2 \end{matrix} & \begin{bmatrix} (1-\alpha') & \alpha' \\ \beta' & (1-\beta') \end{bmatrix} \end{matrix} \quad (3.3.26)$$

Thus α' is the probability that the second farmer would get "sufficient" water given that the first farmer does not get "sufficient" water and β' is the probability that the second farmer does not get "sufficient" water given (or despite the fact) that the first farmer gets "sufficient" water. Thus, both these probabilities α' and β' are expected to be low in general. In the same style that we have adopted in the previous approaches let us find the probability for r or more successes in n trials. In MCM we need to find the probability for r or more visits to state 2. The Moment Generating Function (MGF) of the number of visits to state 2 in n trials $\phi_2^n(\theta)$ is given by (Cox and Miller (1965)).

$$\begin{aligned} \phi_2^n(\theta) &= E(e^{-\theta y_n} | x_0 = 2) \\ &= \frac{\gamma_1^{n+1} - \gamma_2^{n+1} - \mu (\gamma_1^n - \gamma_2^n)}{(\gamma_1 - \gamma_2)} \end{aligned} \quad (3.3.27)$$

where $\mu = 1 - \alpha' - \beta'$ and x_0 refers to the initial state.

Setting $e^{-\theta} = t$, $\alpha = 1 - \alpha'$, and $\beta = 1 - \beta'$

$$\gamma_1, \gamma_2 = \frac{(\alpha + \beta t)}{2} (1 \pm \xi) \quad (3.3.28)$$

where,

$$\xi = \left(1 - \frac{4\mu t}{(\alpha + \beta t)^2}\right)^{1/2} \quad (3.3.29)$$

Now,

$$\begin{aligned} \phi_2^n(t) &= \frac{(\alpha + \beta t)^{n+1}}{2^{n+1}} \left[\frac{(1 + \xi)^{n+1} - (1 - \xi)^{n+1}}{(\alpha + \beta t) \xi} \right] \\ &- \frac{\mu}{2^n} \left[\frac{(1 + \xi)^n - (1 - \xi)^n}{(\alpha + \beta t) \xi} \right] (\alpha + \beta t)^n \end{aligned} \quad (3.3.30)$$

$$\begin{aligned} \phi_2^n(t) &= \frac{(\alpha + \beta t)^{n+1}}{2^{n+1}} \sum_{r=0}^{n+1} \binom{n+1}{r} 1 - (-1)^r \xi^{r-1} \\ &- \frac{\mu}{2^n} (\alpha + \beta t)^{n-1} \sum_{r=0}^n \binom{n}{r} (1 - (-1)^r) \xi^{r-1} \end{aligned} \quad (3.3.31)$$

Now expanding Equation 3.3.29,

$$\xi = \alpha \left(1 + \left(\frac{2\alpha\beta - 4\mu}{\alpha^2}\right)t + \frac{\beta^2 t^2}{\alpha^2}\right)^{1/2} / (\alpha + \beta t) \quad (3.3.32)$$

Setting,

$$\rho_1 = (2\alpha\beta - 4\mu) / \alpha^2 \quad \text{and}$$

$$\rho_2 = \alpha^2 / \beta^2$$

we can write,

$$\xi^r = \frac{\alpha^r}{(\alpha + \beta t)^r} \sum_{k=0}^{r/2} \binom{r/2}{k} \rho_1^k t^k \left(1 + \frac{\rho_2 t}{\rho_1}\right)^k \quad (3.3.33)$$

for even r .

When r is odd:

$$\xi^r = \frac{\alpha^r}{(\alpha + \beta t)^r} \sum_{k=0}^{\infty} \binom{r/2}{k} \rho_1^k t^k \left(1 + \frac{\rho_2 t}{\rho_1}\right)^k \quad (3.3.34)$$

Combining the above 2 equations:

$$\xi^r = \frac{\alpha^r}{(\alpha + \beta t)^r} \sum_{k=0}^{r_0} \binom{r/2}{k} \rho_1^k t^k \left(1 + \rho_0 t\right)^k, \quad (3.3.35)$$

Where $\rho_0 = \rho_2 / \rho_1$ and

$r_0 = r/2$ if r is even.

$= \infty$ if r is odd.

Using Equation 3.3.35 in Equation 3.3.31, we have,

$$\phi_2^n(t) = \frac{1}{2^{n+1}} \sum_{r=0}^{n+1} \binom{n+1}{r} (1 - (-1)^r) \alpha^r (\alpha + \beta t)^{n-r+1} \left(\sum_{k=0}^{r_0} \binom{r-1}{k} (\rho_1 t + \rho_2 t^2)^k \right) \quad (3.3.36)$$

$$= \frac{1}{2^n} \sum_r \binom{n}{r} (1 - (-1)^r) \alpha^{r-1} (\alpha + \beta t)^{n-r} \sum_{k=0}^{r_0} \binom{r-1}{k} (\rho_1 t + \rho_2 t^2)^k$$

Where

$$\begin{aligned} r_0^1 &= \frac{r-1}{2} \text{ if } (r-1) \text{ is even.} \\ &= \infty \text{ if } (r-1) \text{ is odd.} \end{aligned}$$

Let

$$T_1^n(t) = \sum_{r=0}^n \binom{n+1}{r} (1-(-1)^r) \alpha^{r-1} (\alpha + \beta t)^{n-r+1} \sum_{k=0}^{r_0^1} \binom{r-1}{k^2} (\rho_1 t)^k (1+\rho_0 t)^k \quad (3.3.37)$$

and

$$T_2^n(t) = \sum_{r=0}^n \binom{n}{r} (1-(-1)^r) \alpha^{r-1} (\alpha + \beta t)^{n-r+1} \sum_{k=0}^{r_0^1} \binom{r-1}{k^2} (\rho_1 t)^k (1+\rho_0 t)^k \quad (3.3.38)$$

So that

$$\phi_2^n(t) = \frac{T_1^n(t)}{2^{n+1}} - \frac{\mu}{2^n} T_2^n(t) \quad (3.3.39)$$

Let us first expand $T_1(t)$. It can be seen that $T_1^n(t)$ vanishes for even r and $r=0$. Thus, the general term in $T_1^n(t)$ is:

$$2\alpha^{2j} (\alpha + \beta t)^{n-2j} \binom{n+1}{2j+1} \sum_{k=0}^j \binom{j}{k} (\rho_1 t)^k (1+\rho_0 t)^k$$

Now consider the term:

$$\sum_{k=0}^j \binom{j}{k} (\rho_1 t)^k (1+\rho_0 t)^k$$

Suppose we need the coefficient of t^m in the above expression say $T(m, j)$

Let us define,

$$N_m = \frac{m}{2} \text{ if } m \text{ is even.}$$

$$= \frac{m-1}{2} \text{ if } m \text{ is odd.}$$

Then,

$$T(m, j) = \sum_{\ell=0}^{N_m} \binom{j}{m-j} \binom{m-\ell}{\ell} \rho_1^{m-\ell} \rho_0^\ell \quad (3.3.40)$$

Now the general term in $T_1^n(t)$ is:

$$2\alpha^{2j} (\alpha+\beta t)^{n-2j} \binom{n+1}{2j+1} \sum_{k=0}^j \binom{j}{k} \rho_1 t^k (1+\rho_0 t)^k$$

$$= 2\alpha^{2j} (\alpha+\beta t)^{n-2j} \binom{n+1}{2j+1} \sum_{m=0}^{2j} T(m, j)$$

$$= 2\alpha^n \left(\frac{1+\beta t}{\alpha}\right)^{n-2j} \binom{n+1}{2j+1} \sum_{m=0}^{2j} T(m, j)$$

Coefficient of t^M in this expression is given by:

$$\sum_{\ell=a}^b 2\alpha^n \binom{n+1}{2j+1} \binom{n-2j}{\ell} T(M-\ell, j)$$

Where the bounds a and b should be obtained from the inequalities,

$$l \leq n - 2j$$

$$M - l \leq 2j$$

$$M - l \geq 0 \text{ and}$$

$$l \geq 0$$

i.e. $M - 2j \leq l \leq n - 2j$ and

$$0 \leq l \leq M$$

This is given diagrammatically in Figure 3.3.5.

Thus, we can identify two subcases here:

- i) $n - M > M$ i.e. $n > 2M$ and
- ii) $n - M < M$ i.e. $n < 2M$

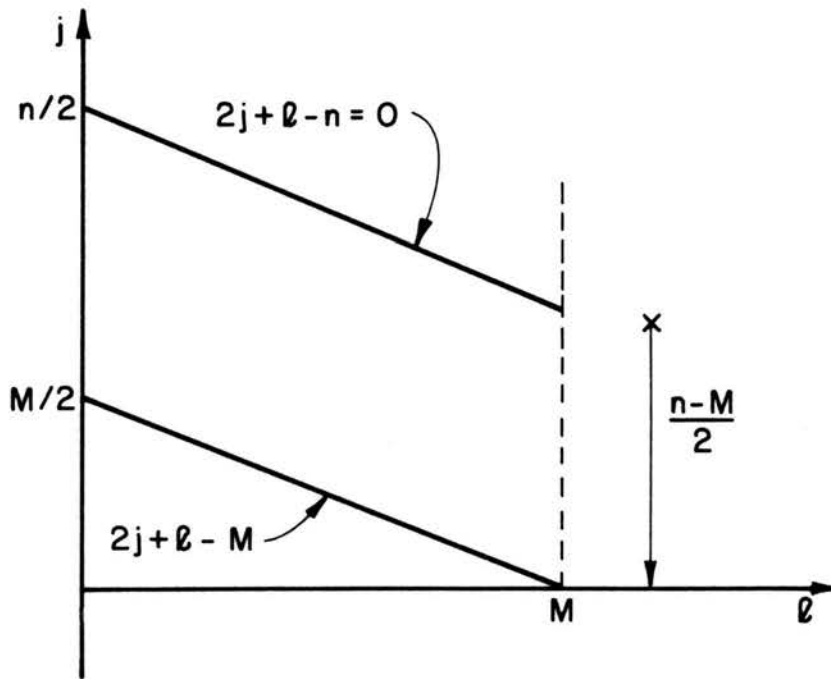

Fig. 3.3.5 General Region of Validity of l and j .

For the case of $n > 2M$ the coefficient of t^M in $T_1^n(r)$ given by:

$$\begin{aligned}
 C_{t^M} = & \sum_{j=0}^{N_M} \left(\sum_{\ell=M-2j}^M 2\alpha^n \binom{n+1}{2j+1} \binom{n-2j}{\ell} T(M-\ell, j) \right) \\
 & + \sum_{j=N_M+1}^{\frac{n-M}{2}} \left(\sum_{\ell=M-2j}^M 2\alpha^n \binom{n+1}{2j+1} T(M-\ell, j) \right) \quad (3.3.41) \\
 & + \sum_{\ell=0}^{n/2} \binom{n-2j}{\ell} 2\alpha^n \binom{n+1}{2j+1} \binom{n-2j}{\ell} T(M-\ell, j) \\
 & \frac{n-M}{2} + 1
 \end{aligned}$$

For the case of $n < 2M$ C_{t^M} is given by: (See Figure 3.3.6)

$$\begin{aligned}
 C_{t^M} = & \sum_{j=0}^{\frac{n-M}{2}} \left(\sum_{\ell=M-2j}^M 2\alpha^n \binom{n+1}{2j+1} \binom{n-2j}{\ell} T(M-\ell, j) \right) \\
 & + \sum_{\ell=0}^{n/2} \binom{n-2j}{\ell} 2\alpha^n \binom{n+1}{2j+1} \binom{n-2j}{\ell} T(M-\ell, j) \quad (3.3.42) \\
 & \frac{n-M}{2} + 1
 \end{aligned}$$

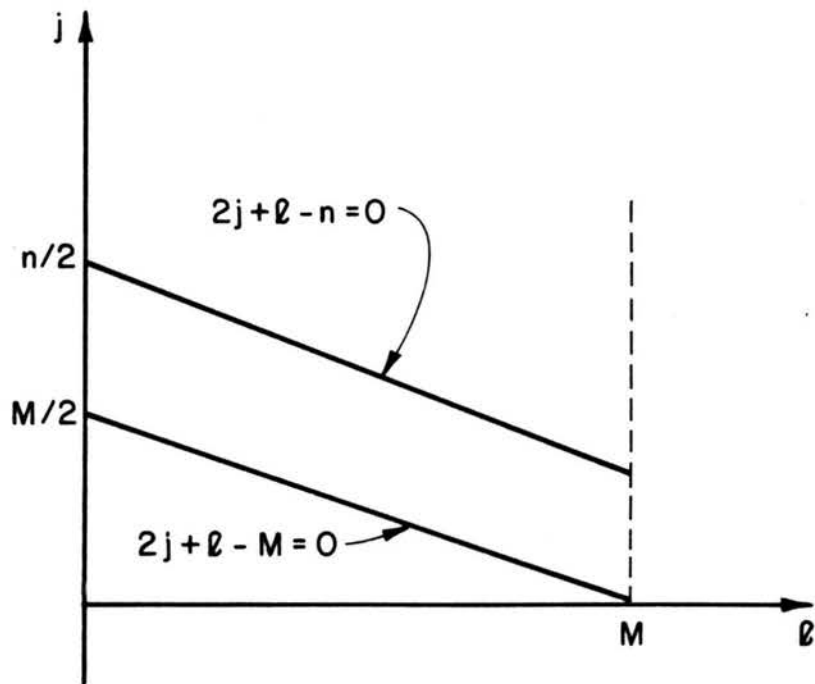

Fig. 3.3.6 Region of Validity for the Case of $M/n > 1/2$.

Similarly, in the expression for $T_2^n(t)$ (Equation 3.3.38) the coefficient of t^M say $(C_{t^M}^1)$, is obtained by replacing n by $n-1$ in expressions 3.3.41 and 3.3.42.

Thus the coefficient of t^M in $\phi_2^n(t)$ is given by:

$$C_{\phi_M} = \frac{C_{t^M}^1}{2^{n+1}} - \frac{\mu}{2^n} C_{t^M}^1 \quad (3.3.43)$$

It should be noted that we will mostly deal with the case of $n/M > 1/2$ and hence would be using expression 3.3.42 for the evaluation of C_{ϕ} .

Cox and Miller (1965) give the asymptotic mean and variance for the proportion of success as:

$$E(Y_n/n) = \alpha' / (\alpha' + \beta')$$

$$V(Y_n/n) = \frac{\alpha' \beta' (2 - \alpha' - \beta')}{n^2 (\alpha' + \beta')^3}$$

where Y_n is the number of visits to state 2 (or successes) in n trials.

Using a computer program for the computations of C_{ϕ_M} , the values of C_{ϕ_M} are given in Appendix 3.2 the results for the following cases for $xps = 75\%$:

- i) $\alpha' = \beta' = .02$
- ii) $\alpha' = \beta' = .03$
- iii) $\alpha' = \beta' = .04$
- iv) $\alpha' = \beta' = .05$
- v) $\alpha' = .07$ and $\beta' = .03$

In this case the probability of achieving at least 75% successes in a group decreases as n increases. The transition probabilities α' and β' again would be a combination of physical and social factors and have to be estimated from available data and with an insight about possible cooperation amongst farmers.

(v) 4x4 Markov Chain Model.

In Method (iv) we dealt with a simple MCM with only 2 states and it was found out that computational efforts are great when one tries to find out the probabilities of at least a specified proportion of visits to a particular state. Thus, when a larger transition probability matrix is involved it is suitable to work with the expected values of visits to a particular state rather than the exact distribution of visits to that state.

In the present approach the following states are identified:

- 1) The event of a farmer obtaining "sufficient" water and releasing to the next farmer according to the rules,
- 2) The event of a farmer not obtaining "sufficient" water and still releasing to the next farmer according to the rules,
- 3) The event of a farmer obtaining "sufficient" water and not releasing to the next farmer according to the rules, and
- 4) The event of a farmer not obtaining "sufficient" water and not releasing to the next farmer according to the rules.

The farmers in states 1 and 4 could be categorized as "normal" men/women under favorable and adverse circumstances respectively. Whereas, those in state 2 could be categorized as "good", those in state 3 could be categorized as "bad". In this way the characteristics of the attitudes could be more easily handled.

Now the transition probability matrix could be written as:

$$P=(P_{ij})$$

$$P = \begin{bmatrix} p_{11} & 0 & (1-p_{11}) & 0 \\ 0 & p_{22} & 0 & (1-p_{22}) \\ 0 & p_{32} & 0 & (1-p_{32}) \\ 0 & p_{42} & 0 & (1-p_{42}) \end{bmatrix} \quad (3.3.44)$$

The initial probability vector could be written as:

$$\underline{p}_0 = (\xi_1, 0, 1-\xi_1, 0), \quad (3.3.45)$$

assuming that the first farmer is always assured of sufficient water. This is appropriate in a design process. The probability vector at the n^{th} stage will be given by:

$$\underline{p}(n) = \underline{p}(0) [P]^n \quad (3.3.46)$$

We could compute the expected number of visits to, say, state j , in n steps assuming that the system starts in state i using the following technique. (See Rau, (1970)).

Let a random variable, $y_{i,j}(\ell) = 1$ if the state at the ℓ^{th} step is j and $y_{i,j}(\ell) = 0$ if it is not j .

Now,

$$E \left(\sum_{\ell=1}^n y_{i,j}(\ell) \right) = \sum_{\ell=1}^n E \left(y_{i,j}(\ell) \right) \quad (3.3.47)$$

i.e.

$$E \left(\sum_{\ell=1}^n y_{i,j}(\ell) \right) = \sum_{\ell=1}^n P_{i,j}(\ell) \quad (3.3.48)$$

$$= \sum_{\ell=1}^n P_{i,j} [P]^{\ell}$$

$$E \left(\sum_{\ell=1}^n y_{i,j}(\ell) \right) = P_{i,j} \left[P + P^2 + \dots + P^n \right] \quad (3.3.49)$$

Appendix 3.3 gives the program and results for the case of following parameters:

$$P_{11} = .95,$$

$$P_{22} = .35,$$

$$P_{32} = .30,$$

$$P_{42} = .50, \text{ and } \xi = .95$$

As in the cases of Method (ii) (using beta distribution and BTM) and Method (iii) we can see that the percentage of visits to state 1 in this case (the desired state) reduces as n increases.

In summary we observe the following in the study of turnout area interactions:

- 1) The results of the case of the basic BTM with a uniform probability of success, which is related functionally to the parameters involved, indicated that when one expects more proportion of success than this probability, it is preferable to reduce the number of farmers in a turnout area.
- 2) When a given distribution is ascribed to the probability of success, the probability of getting at least a required fraction of success reduces as the number of farmers in the turnout area increases.
- 3) When the probability of success of each farmer reduces geometrically with parameter, ξ , there is a range of values of the number of farmers in the turnout area for which the probability of getting at least a specified fraction becomes maximum, for $\xi \geq .95$. For lower values the latter probability decreases.
- 4) In Markov Chain modeling with a 2x2 transition matrix the probability of getting at least a specified percentage of success becomes lower when the group size increases. With a 4x4 transition matrix the expected proportion of successes reduces as the group size increases.

The extended BTM (EBTM) with geometrically reducing probabilities and the Markov Chain Model (MCM) to a great extent account for the sequential dependence. The ratio, ξ , in EBTM and transition probabilities in the MCM need be further decomposed to account for the physical factors and the

sociological factors. Assuming independence between these two factors may not be valid since the nature of the physical system may stimulate a particular response from the farmer.

3.4 ECONOMIC ANALYSIS OF TURNOUT AREA SIZES

In the previous section an analysis of the turnout area sizes was made using probabilistic models. Using different kinds of models, the variation of the probability of getting a required proportion of successes with the number, n , of farmers in a turnout area was studied. In the case of EBTM with geometrically reducing probabilities it was seen that this probability was a maximum for given ranges of n when the successive probabilities ratio satisfied the inequality

$$0.96 \leq \xi < 1 \quad (3.4.1)$$

In other ranges of ξ and for other models it was seen that this probability reduces as n increases. Thus, in general, the number of farmers in a turnout area should be as low as possible. However, this may result in higher construction and maintenance costs, since we would need more turnouts. On the other hand considering only the economic factors of construction and maintenance for turnouts, we would be trying to have more farmers within a turnout area. Thus, an economic analysis considering also the expected performance of the microsystem of the turnout area using the probabilistic models studied for the turnout area interactions is in order.

The final measure of the performance of the system is the yields of the crop or crops grown in the area irrigated. This can be correlated with the performance of the irrigation system in its water delivery aspect. In an economic analysis, it is assumed this correlation is one to one with the other inputs towards the yield at their given values. Also, in a design process, the

attempt would be to assure water delivery to the terminal units - the turnout areas - with a very high probability. Once this is managed, the performance of the irrigation system can be seen to critically depend on the performance of the turnout areas and it becomes appropriate to analyze the performance of the whole project varying the turnout area parameters.

The context of economic analysis here will be that of a government funding the construction and maintenance of the project features including the terminal outlets. Modifications for private work are not untenable. Also, when benefits are dealt with, the tenet of "the benefits to whomsoever they may accrue" would be used.

The economic objective function, which now is a function of terminal unit parameters, may either have an optimum within the ranges of the parameters including the boundaries or show monotonicity. In the latter case, as will be seen subsequently, we may have to impose a certain level of performance as a constraint to the objective function and obtain the values of the parameters that we are seeking.

We have four widely used methods of economic analysis that use the discounting of the values of the benefits and costs in time of an activity. Namely, they are, the rate of return method, the present worth method, the benefit-cost ratio method and the annual cost method. (See James and Lee (1971)). If our objective function is, say, the benefit cost ratio and if we studied the variation of it with the number of farmers, n , in a turnout area we might find that this ratio decreases as n increases. Or we might find that this ratio is maximum at a particular value of n that is not a boundary. In the former case of monotonicity, we need to derive the optimal value of n either by imposing limits on the benefit-cost ratio or by extraneous considerations such as administrative criteria.

Let us now consider some aspects of the economic analysis at a project scale. In a project area where the farm sizes have been chosen or already given, the canal network density will be assumed not to be altered by changes in the turnout area sizes. This assumption leads to the following:

- (i) Canal construction costs need not be varied as the turnout area size is varied, and;
- (ii) cost of water lost within a turnout area due to seepage need not be accounted for, since, when the whole area is considered this loss could remain the same.

The situation that is studied is simply as follows: we have a network of canals and we try to add control structures in this network terminally, at suitable points.

Once this is assumed, an economic objective function needs to be selected. Since the benefit-cost ratio method is a frequently used one, we will examine how the turnout area performance may be coupled to the benefit stream in this method. The other types of objective functions are handled in a similar manner. Also, we will assume simple forms of benefit and cost streams.

Let us say, we have an irrigation project of extent A_p . Let the following be the rest of the notations:

- A_f - The extent of individual farm size (assumed uniform),
- A_T - the extent of turnout area,
- B_C - the unit price of the produce of crops,
- B_S - the annual flood protection benefits per unit extent,
- C_T - the cost of construction of a turnout to serve a turnout area of extent, A_T ,
- C_O - the cost of operating and maintaining a turnout,
- i - the discount rate in fraction,
- N_l - the life period of the project (years),
- N_T - the total number of turnouts in the project area,
- P_c - the cost of constructing the necessary structures including the headworks and the conveyance systems excluding the turnouts,
- P_m - the annual cost of maintaining the above systems,
- $\overline{p}(n)$ - the expected proportion of successes in a turnout area,
- Y_c - the annual yeild of crop in unit extent, and;
- V_c - the annual cultivation costs per unit extent.

Assuming that the construction costs are uniformly spread over N_c years and that the replacement costs are negligible, the total cost including the costs of operating and maintaining the systems excluding the turnouts is given by:

$$C_1 = \frac{P_c}{N_c} + \frac{P_c}{N_c} \sum_{r=1}^{N_c} \frac{1}{(1+i)^r} + P_m \sum_{r=N_c+1}^{N_l+N_c} \frac{1}{(1+i)^r} \quad (3.4.2)$$

In Equation 3.4.2 for P_m , an average value may be used to account for the increase in maintenance costs over the years to come.

Equation 3.4.2 further assumes that maintenance begins only after the full construction of the project. The cost of constructing a turnout to serve an area of A_T may be given by:

$$C_T = a_1 A_T^b \quad (3.4.3)$$

The total construction cost of turnouts is given by:

$$C_T N_T = \frac{A_p}{A_T} a_1 A_T^{b_1}$$

Since $A_T = nA_f$ the above can be written as:

$$C_T N_T = A_p a_1 A_f^{b_1-1} n^{b_1-1} = an^b \quad (3.4.4)$$

where,

$$a = a_1 A_p A_f^{b_1-1}$$

and

$$b = b_1 - 1$$

Assuming this cost is spent at the end of the N_c th year, the contribution of this to the present cost stream $C_2(n)$ will be given by:

$$C_2(n) = \frac{an^b}{(1+i)^{N_c}} \quad (3.4.5)$$

The operation and maintenance cost for the turnouts is given by:

$$C_3(n) = N_T C_0 \sum_{r=N_{c+1}}^{N_c + N_d} \frac{1}{(1+i)^r}$$

$$C_3(n) = \frac{A_p C_0}{n A_f} \sum_{r=N_{c+1}}^{N_c + N_e} \frac{1}{(1+i)^r} \quad (3.4.6)$$

The total cost $C(n)$ will be given by:

$$C(n) = C_1 + C_2(n) + C_3(n) \quad (3.4.7)$$

If we assume that the irrigation and flood protection benefits begin accruing after N_c years, then the benefit stream is given by:

$$B(n) = A_p (Y_c B_c \bar{p}(n) + B_s - V_c) \sum_{r=N_{c+1}}^{N_c + N_d} \frac{1}{(1+i)^r} \quad (3.4.8)$$

The benefit-cost ratio, $\lambda(n)$, is now given by:

$$\lambda(n) = \frac{B(n)}{C(n)} = \frac{A_p (Y_c B_c \bar{p}(n) + B_s - V_c) \sum_{r=N_{c+1}}^{N_c + N_d} \frac{1}{(1+i)^r}}{C_1 + C_2(n) + C_3(n)} \quad (3.4.9)$$

In this expression for the benefit cost ratio, λ , the model for success in turnout area interactions derived in the previous chapter may be substituted and the value of n at the maximum value of λ may be obtained.

It is worthwhile to look at an example. Suppose we had a project area with the following details:

Extent of project area $A_p = 100,000$ acres

Individual farm size $A_f = 5$ acres.

Annual Yield of crop grown (rice paddy) $Y_c = 140$ bushels/acre
(assume 2 seasons).

Price of crop grown $B_c = \$3.5/\text{bushel}$.

Discount rate $i = 0.15$.

Life period of the project, $N_c = 50$ years.

Cost of construction of systems including the turnouts,

$P_c = 60 \times 10^6$ \$.

Maintenance of the above systems, $P_m = 1 \times 10^6$ \$ per year.

Flood protection benefits, $B_s = \$20$ per acre per year.

The cost curve for constructing a single turnout is, say,

$$C_T = 80 A_T^{0.4}$$

i.e.,

$$a_1 = 80 \text{ and } b_1 = 0.4$$

Let the operations and maintenance cost of a turnout, $C_0 = \$40/\text{year}$.

Let us say a team of sociologists and engineers find that an EBTM with geometrically reducing probabilities is appropriate for the turnout area interaction with the values for the model's parameters, ξ and p_1 set at 0.9 and 1.0 respectively. Table 3.4.1 gives the variation of the benefit - cost ratio, λ , with n .

Suppose we require a minimum B/C ratio of 1.10, then the number of turnout areas farmers should be limited to 20.

If the turnout area interaction model has been, say, 2×2 Markovian, then $\bar{p}(n)$ will be given by:

$$\bar{p}(n) = \frac{1}{n} \sum_{k=1}^n \frac{\alpha'}{\alpha'+\beta'} + \frac{\beta'(1-\alpha'-\beta')^k}{(\alpha'+\beta')} \quad (3.4.10)$$

(See Bhat (1972)).

i.e.

$$\bar{p}(n) = \frac{\alpha'}{\alpha'+\beta'} + \frac{\beta'}{n(\alpha'+\beta')} (1-\alpha'-\beta') \frac{(1-(1-\alpha'-\beta')^n)}{(\alpha'+\beta')} \quad (3.4.11)$$

If in our present example the turnout area interactions had been given by a 2×2 MCM with $\alpha' = .07$ and $\beta' = .03$, we have for $\bar{p}(n)$,

$$\bar{p}(n) = .70 + \frac{2.70}{n} (1-.9^n) \quad (3.4.12)$$

For this case, Table 3.4.2 gives the variation of the benefit-cost ratio, λ , with n . In this case, if it is stipulated that we should have at least 1.10 for λ , then the number of farmers that can be allowed to share a turnout area is 40.

TABLE 3.4.1

Variation of λ with n for EBTM

n	λ
2	1.73
4	1.68
6	1.61
8	1.54
10	1.47
12	1.40
14	1.33
16	1.26
18	1.20
20	1.14
22	1.08
24	1.02
26	.97

TABLE 3.4.2
VARIATION OF λ WITH n FOR A 2x2 MCM

n	λ
2	1.65
4	1.61
6	1.56
8	1.51
10	1.47
12	1.43
14	1.39
16	1.36
18	1.33
20	1.31
22	1.29
24	1.27
26	1.25
28	1.23
30	1.22
32	1.20
34	1.19
36	1.18
38	1.17
40	1.10

3.5 CONCLUSIONS AND RECOMMENDATIONS

Reviewing the literature related to the problem of turnout area irrigation interactions, the identified sociological and physical factors were discussed and taking a causal processes theory (of mathematical sociology) approach, the basic BTM and three of its extensions to study this problem were attempted. These theoretical models were prepared using parameters that are of essentially physical and of sociological type. The economic aspects of this problem using the models constructed were also given.

Primarily, two quantities were of our concern in the probabilistic models that were used. One is the expected proportion of success (in the sense of receiving "sufficient" irrigation water) amongst the group of farmers in a turnout area and the other is the probability of achieving a given percentage or more successes amongst the turnout area farmers. The extended BTM with geometrically reducing probabilities is more applicable to turnout areas where continuous water delivery takes place and where there exists a good degree of cooperation amongst the farmers. In this case it was found out that for the case of successive probabilities ratio taking a value between 0.96 and 1, the probability of getting a required fraction or more of successes peaked for certain ranges of n . These ranges were from 10-14 to 20-24, and incidentally, are not very far from Wade's (1976) suspicion that this range is 10-15. However, we saw that the expected proportion of success in this model decreased as the number of farmers in the turnout area increased, confirming the initial premise that indeed there is an optimum number of farmers who may be allowed to share a single turnout. In this model, the successive probabilities ratio, ξ , is expected to be arrived at interdisciplinarily by sociologists and engineers. Decomposition of ξ into the associated sociological and physical factors is recommended for further research. As far as

sociological directions are considered, the primary attitudes towards sharing the water and responses in this regard should be studied, instead of studying secondary factors such as power, influence, etc.

In the study of using Markov Chains, two kinds of studies were undertaken. First, was to use a simple 2x2 Model was used to find the expected proportion of successes and the second was to find the probability of getting a required or more percentage of success. This model is more applicable to rotational type systems where the dependence of a farmer on his neighbor upstream of the ditch is great. It was found out that both the above mentioned quantities decreased as the number of farmers in the turnout area increased. Then a 4x4 MCM was used to find the expected proportion of successes in a turnout area. This study also showed that as the number of farmers in the turnout area increased the expected proportion of successes decreased. Again, in these Markov Chain Models, the transition probabilities need be decomposed into the associated physical and sociological factors interdisciplinarily. The recommendations made for EBTM are also valid for these models.

Measurements of the successive probabilities ratio in the EBTM and the transition probabilities in the MCM have not been discussed in this module. In a project that is to be constructed, the values for these parameters may be measured from data collected in an existing project that may have the individual farm sizes closer to the farm sizes in the project area designed. In this case the sociological factors and the other physical factors should be appropriately extended to the new project conditions. Again, as has been mentioned previously, adjustments should be made for an evolved condition

rather than for instantaneous conditions. It might also be very useful to develop purposive action theory models for turnout area interactions, which is recommended for further research.

Once it was realized that, in general, it is preferable to have as few farmers as possible, the economics associated with the turnout size was studied. In the context of a government providing irrigation facilities, the flow of the benefit stream is dependent on the expected proportion of successes in the turnout area. A benefit-cost ratio formula using the models constructed previously for a simple case of an irrigation project was given. This formula was exemplified using a set of values (which closely follow Sri Lankan rates, typical for third world). Such an economic study indicated that we should prescribe certain levels of economic performance to pick out a value for the number of farmers in a turnout area. The economic study could be extended in its scope by considering the various kinds of benefits and costs that are generally hidden.

CHAPTER 4

TURNOUT AREA WATER REQUIREMENTS MODULE

4.1 INTRODUCTION

Surface water requirements within a turnout area depend on the climatic conditions, types and extent of crops grown, planting time and the water table contributions, if any. In general, water requirements depend also on the allowable soil moisture stress. Evapotranspiration is the mechanism by which soil moisture is depleted in an irrigated field and hence this will be mainly studied in relation to turnout area water requirements. Evapotranspiration amounts from crop areas are normally given in units of depth for a given interval of time and involve parameters that are stochastic in nature.

The evapotranspiration amounts are used to compute the irrigation intervals and the depths of application of water. The farm application system is designed to issue the water to meet these requirements. The objective of this module is to describe the procedures by which the uncertainties in the evapotranspiration can be accounted for and by which optimal depth scheduling for a multi-crop area can be calculated.

4.2 REVIEW OF LITERATURE OF EVAPOTRANSPIRATION MODELING

4.2.1 Generalities

An area that is planted with crops when supplied with heat energy from its environs loses soil moisture if the atmospheric conditions are suitable for removal of vapor (Hillel (1971)). This happens by the crop canopy losing water to the atmosphere by vaporization (transpiration) and the soil losing water by direct evaporation. Thus, to model evapotranspiration it is possible to model

these two processes separately and combine them suitably. Since our interest is crop water use in units of depth (i.e. volume per unit crop area), transpiration becomes the main component in relatively a short time after plants begin to take cover. Therefore, Penman's definition (Hillel (1971)) for potential evapotranspiration that, "... the amount of water transpired in unit time by a short green crop, completely shading the ground, of uniform height and never short of water" appears reasonable.

4.2.2 Transpiration Models

There has been many attempts to model the water uptake by plants. A good review of the state of this art may be found in Gardner et. al. (1975). They proposed that, in view of the unsatisfactory nature of the assumptions made in modeling water uptake by plants, empirical approaches are preferable. Also, in such modeling of water intake, we need a good amount of data that may not be normally available to designers. For instance, in the model developed by Nimah and Hanks (1973), we require the following input data:

- (1) Hydraulic conductivity - water content and pressure head water content data covering the range of water content that might be encountered,
- (2) Dry and saturated soil water contents,
- (3) Soil water potential at which the plant wilts and the potential below which actual transpiration will be lesser than the potential transpiration,
- (4) The distribution function of root density in the vertical directions (assumed stationary),
- (5) Initial moisture content profile,

- (6) Potential evaporation and transpiration data (Penman's Equation)
- (7) Osmotic potential of infiltrating and initially contained waters and
- (8) Water table data.

These data requirements are extensive and when computations are made for the whole irrigation season, the method would require a good amount of computing resources. Thus, it is preferable to work with empirical approaches to calculate crop transpiration.

4.2.3 Evaporation Models

Evaporation models fall into two fundamental methods - the diffusion method and the energy balance method (Eagleson (1970)). The method that is popular and widely used is due to Penman (1948) and is considered to be a combination of both the above fundamental approaches. A review of a form of Penman's equation may be found in Hillel (1971) and is given below. Let us use the following notations:

- J_n = Net radiation received by the moist surface (cal/cm^2 per unit time),
- Δ = Slope of the saturated vapor pressure - temperature curve,
- β = Bowen's ratio (the ratio of sensible heat lost to the atmosphere to the latent heat),
- ξ = The psychrometric constant (in $\text{mb}/^\circ\text{C}$),
- T_s = Water surface temperature ($^\circ\text{C}$)
- T_a = Air temperature "near" surface ($^\circ\text{C}$)
- e_s = Saturation vapor pressure at surface water temperature (mm of Hg)
- e = Mean vapor pressure in air (mm of Hg)
- L = Latent heat of vaporization (Cal/gm)
- u_2 = Mean wind velocity in miles/day at 2 m above ground

Now evaporation from a surface can be given by:

$$E = \frac{(\Delta/\xi) J_n + a (e_s - e) (b + cu_2)}{(\Delta/\xi + 1) L} \quad \text{cm/day} \quad (4.2.1)$$

where a, b and c are constants.

Thus, the evaporation from a moist surface depends on Δ , J_n , U_2 and the temperatures of the water surface and air. This equation assumes that the contribution of the net radiation towards heating up of the soil is negligible. This may be corrected by multiplying J_n by an empirical positive constant to account for the heating up of the soil.

The coefficients in the vapor diffusion term, $a (e_s - e) (b + cu_2)$, in Equation (4.2.1) in the original Penman's derivation (Penman (1948)) was empirically developed.

The general equation for potential evaporation is regarded as:

$$E = \frac{(\Delta/\gamma) J_n + B_u L (e_a - e)}{(\Delta/\gamma + 1) L} \quad (4.2.2)$$

Where B_u is a turbulent transfer coefficient dependent upon surface roughness, wind velocity and the elevations at which these measurements are taken. This is called the modified Penman's equation (Eagleson (1970)) and B_u is given (when LE is given in $\text{Cal Cm}^{-2} \text{min}^{-1}$) (Van Bavel (1966)).

$$B_u = \frac{\rho \epsilon k^2 U_a}{\rho [\ln (Z_a/Z_0)]^2} \quad \text{g cm}^{-2} \text{min}^{-1} \text{mb}^{-1} \quad (4.2.3)$$

Where:

- ρ = Density of Air in g cm^{-3} ,
- ϵ = Water Air Molecular Ratio,
- k = Von Karman's Universal Constant,
- p = The Ambient Pressure (in the same units as vapor pressure),

- U = Wind velocity in cm/min,
Z_a = The elevation above the surface (cm) and,
Z_o = The roughness parameter, cm.

Van Bavel (1966) set Z_a = 2 meters as did Penman (1948). Z_o was found by Van Bavel (1966) for alfalfa as 1 cm and for smooth open water surface as .001 cms under many different conditions. An important finding of Van Bavel (ibid) is that daily average values for the terms in Equation 4.2.2 is sufficient for the determination of daily potential evaporation. Equation 4.2.2 is used for the evapotranspiration model.

Evapotranspiration Models

Evapotranspiration models are numerous and the two widely used references, as of now, on the subject are by Doorenbos and Pruitt (1975), (1977), and Jensen (1973). As was mentioned previously, combining transpiration models and evaporation models to give evapotranspiration will not be followed due to the extensive data needed. Also, evapotranspiration of turnout areas with field crops rather than orchard crops will be mainly our interest.

The terms, evapotranspiration and consumptive use have been treated synonymously, although only a very little amount of water is really used by the plants for their growth. Thus, plants consume soil water mostly to transpire to the atmosphere. Evaporation of moisture from the leaf surfaces is a basic mechanism by which soil moisture is lost to the atmosphere. The roots, the stem and the stomata of the plants offer resistance to the flow of moisture from the soil to the atmosphere. Evapotranspiration also depends on the amount of moisture in the soil. In order to deal with this situation, Jensen (1968) separated the evaporative demand of the atmosphere from the nature of

the plant and the soil moisture availability in the following manner. The instantaneous evapotranspiration, ET , of a crop is given by:

$$ET = K_c ET_p \quad (4.2.4)$$

where ET_p is the potential evapotranspiration and K_c is a coefficient which is a function of soil water availability, nature and growth stage of the crops.

The daily or any period values of the consumptive use W_u , are found from:

$$W_u = \int_{t_1}^{t_2} ET dt = \int_{t_1}^{t_2} K_c ET_p dt, \quad (4.2.5)$$

where t_1 and t_2 are the time limits.

The potential evapotranspiration, ET_p , is defined as the evapotranspiration of a reference crop that has an aerodynamically rough surface when the soil water is not limiting. In many works in the United States, alfalfa with a height of 30-50 cm is taken as the reference crop (Jensen (1968)). Doorenbos and Pruitt (1975) however, define ET as "the rate of evapotranspiration from an extended surface of 8 to 15 cm tall green grass cover of uniform height, actively growing, completely shading the ground and not short of water". Since Van Bavel (1966) found out that the roughness term Z_o in Equation (4.2.3) is not very critical (within a factor of 2) we can ignore this difference as far as aerodynamic roughness is concerned. Once the proper aerodynamic roughness is assumed, the modified Penman Equation (4.2.2) is used for the evaluation of potential evapotranspiration. Penman's Equation (4.2.1) or (4.2.2) is considered to give good results when adequate data are available (Boonyatharokul (1979)). Other methods available for the evaluation

of potential evapotranspiration are classified as follows (Doorenbos and Pruitt (1975) or (1977)):

- (1) Blaney - Griddle,
- (2) Radiation, and
- (3) Pan Evaporation.

Since Blaney-Criddle is not suggested for short term periods less than a month (Doorenbos and Pruitt (1977) and pan evaporation method requires measured data which might not be available as easily as the normal climatological data, the radiation method by Jensen and Haise (Jensen (1973)) is preferable.

In the Jensen and Haise method, the potential evapotranspiration E_{tp} is given by

$$E_{tp} = C_T (T - T_x) R_s \quad (4.2.6)$$

where

$$C_T = \frac{305 (e_2 - e_1)}{(11590 - 2E) (e_2 - e_1) + 111325} \quad (4.2.7)$$

and

$$T_x = -2.5 - 0.14 (e_2 - e_1) - \frac{E}{550} \quad (4.2.8)$$

The notations are:

- | | | |
|------------|---|--|
| E | = | The elevation of the crop area in meters |
| T | = | The mean daily temperature °C |
| R_s | = | The mean daily incident radiation in units of E_{tp} |
| e_2, e_1 | = | The saturation vapour pressures (mb) at the mean monthly maximum and minimum temperatures for the warmest month in the year. |

The details of these methods and the data requirements as judged by Doorenbos and Pruitt (1977) may be found in the same reference.

Difficulties however, arise in the evaluation of coefficient K_c in Equation (4.2.4). The atmosphere demands an amount of evaporative flux through the plant and this is attempted to be met by the plant as far as possible from the soil. The soil and the plant system adjust to the demand depending on the soil moisture availability, soil characteristics and on the plant's system's characteristics. In order to separate the soil moisture component from plant characteristics component of the actual evapotranspiration, Jensen et. al. (1970) proposed that:

$$K_c = K_a K_{co} + K_s, \quad (4.2.9)$$

in which K_a is a coefficient that reflects the soil moisture availability, K_{co} is a coefficient reflecting the crop characteristics as it grows when soil moisture is not limiting and K_s is a coefficient at any given stage of growth reflecting the sudden ease in soil moisture due to irrigation or rainfall. Kincaid and Heerman (1974) expressed K_{co} as:

$$K_{co} = Ar^3 + Br^2 + Cr + D \quad (4.2.10)$$

where A, B, C and D are coefficients and r is the fraction of time from planting to effective cover. After effective cover, r, is the number of days beyond effective cover to date. Kincaid and Heerman (1974) gave the values of A, B, C and D for a variety of crops. In tabular form Jensen (1973) has given K_{co} values for different crops. K_s is generally given by (Boonyatharakol (1979)):

$$K_s = (9 - K_{ci}) e^{-\lambda t} \quad (4.2.11)$$

where K_{ci} is the value of K_c at the onset of irrigation or rain, λ is a coefficient representing evaporative demand, soil characteristics, etc. and it

is the time after the irrigation or rainfall event. Equation (4.2.11) can be given approximately (Kincaid and Heerman (1974) and Neghassi (1974)) as:

$$K_s = (.90 - K_c) m \quad (4.2.12)$$

where:

$m = .8, .5$ and $.3$ when t (days) = 1, 2 and 3 respectively.

If $K_c \geq .90$ or no irrigation or rain occurred at $t \geq 3$, then,

$$K_s = 0 \text{ for } t > 3$$

The coefficient, K_a , in Equation (4.2.9) has been given by many different formulae and a review of these may be found in Boonytharakol (1979). The popular models for K_a had been the logarithmic moisture deficit function of Jensen et. al. (1970) and the linear model of Thornthwaite and Mather (1955) (See also Cordova and Bras (1979)).

The logarithmic model proposed that:

$$K_a = \log (1 + 100 (1 - D_p / D_t)) / \log 101 \quad (4.2.13)$$

Where D_p is the soil moisture depletion and D_t is the total available moisture in units of depth. The basic linear model proposed that:

$$K_a = 1 - \frac{D_p}{D_t} \quad (4.2.14)$$

The basic linear model was further modified in the following fashion (See Marlett et. al. (1961), Hanks (1974)).

$$K_a = \frac{1}{b} \left[1 - \frac{D_p}{D_t} \right] ; K_a \leq 1.0, \quad (4.2.15)$$

where b is the fraction of remaining available soil moisture.

Equation (4.2.15) gives $K_a = 1.0$ up to the point corresponding to b and then varies linearly until the permanent wilting point. All these models, it

should be noted, are functions of only depleted soil moisture, D_p , and total available water, D_t . Boonyatharakol (1979) did an extensive study of this problem using a finite difference model for the soil moisture component. This model is similar to the model of Nimah and Hanks (1973) but treats differently the sink term, $S(z,t)$, in the vertical moisture flow equation

$$\frac{\partial \theta}{\partial t} = \frac{\partial}{\partial z} \left[K(\theta) \left(\frac{\partial h}{\partial z} - 1 \right) \right] - S(z, t) \quad (4.2.16)$$

where θ is the volumetric soil moisture content, h the soil water potential, $K(\theta)$ the hydraulic conductivity of the soil, t the time and z the vertical distance from the soil surface (positive downward). In general, $S(z,t)$ is expressed (Feddes et. al. (1976)) as:

$$S(z, t) = - K(\theta) (h_r - h_s) b' \quad (4.2.17)$$

in which h_r is the soil water potential at the root-soil interface, and h_s is the potential at some distance from this interface and b' is an empirical root effectiveness function. Nimah and Hanks (1973) adjusted h_s for the osmotic potential and h_r for a root resistance by a factor proportional to the depth. They expressed b' as:

$$b' = \frac{RDF(z)}{\Delta x \Delta z} \quad (4.2.18)$$

where, $RDF(z)$ is the root density function, Δz the depth increment and Δx the distance at which h_s is measured (which was arbitrarily set equal to 1). The h_r was adjusted to give the total intake equal to the potential evapotranspiration provided h_r is greater than or equal to the wilting point soil water potential. The root density function, as the name implies, gives an idea about the distribution of roots in the root zone.

Boonyatharakol (1979), recognizing the importance of the root density function, the evaporative demand and the soil characteristics, modeled the sink term as:

$$S(z,t) = \frac{T \cdot U(t) \cdot R(z')}{\Delta z} (1 - (D_p/D_t)^\beta) \quad (4.2.19)$$

where T is the transpiration rate, $U(t)$ is the time distribution of T , $R(z')$ is the water uptake function of relative depth z' and β is a coefficient expressed empirically as:

$$\beta = a \frac{K_{sat}}{T} + b'_o \quad (4.2.20)$$

where a and b'_o are constants. K_{sat} is the saturated hydraulic conductivity of the soil. Also T is given as:

$$T = K_{co} E T_p \quad (4.2.21)$$

Comparing Equation (4.2.18) and Equation (4.2.19) it may be seen that $R(z')$ conveniently replaces the $RDF(z)$ of Hanks and Nimah (1973). Boonyatharakol's study also consists of an experimental evaluation of actual and potential evapotranspirations of alfalfa and hence is of importance. Firstly, coefficients a and b'_o in Equation (4.2.20) were identified to match the observed data. Once these were calibrated, the finite difference model was used to simulate various root extraction and evaporation terms to identify a general model for K_a . The following type was proposed:

$$K_a = (1.0 - (D_p/D_t)^m)^n ; m, n > 0 \quad (4.2.22)$$

where m and n are coefficients that are functions of K_{sat} , T , the root extraction function, $R(z')$, and soil hydraulic conductivity property. The performance of Equation (4.2.22) was also compared with the linear model (Equation (4.2.15)) and the logarithmic model (Equation (4.2.13)). Further,

Boonyatharakol's (1979) study indicated that, by making the coefficient b in the linear model given by Equation (4.2.15) a function of K_{sat} , T and $R(z')$, we could get as good a result as with the power model (Equation (4.2.22)). Since this is more adaptable for water requirements modeling, it is preferable to use the results of Boonyatharakol (1979) in this regards. These results are given (in Tables 21 and 22) by Boonyatharakol (ibid). The following general expression for b was given by:

$$b = 0.4229 + 0.1572 R_0 - 0.00790 \left(\frac{K_{sat}}{T} \right) + 0.00006 \left(\frac{K_{sat}}{T} \right)^2 \quad (4.2.23)$$

where R_0 is the value of water uptake distribution at $z' = 0$. In the absence of data about K_{sat} , we might get reasonable results using $b = 0.548$ (the average of .545, .575 and .525 given for 3 stress periods reported by Boonyatharakol (1979)).

The procedures given by Doorenbos and Pruitt (1975) to compute evapotranspiration, give K_c values directly instead of splitting up K_c as given in Equation (4.2.9).

4.3 UNCERTAINTY IN WATER REQUIREMENTS

4.3.1 Generalities

When turnout area water requirements are to be computed it is essential to analyze the following factors that give rise to uncertainty (in the water requirements):

- (1) Variations in cropping patterns,
- (2) Variations in rainfall and evapotranspiration,
- (3) Variations in cropping schedules,
- (4) Variations in the ground water table level in cases of significant ground water contribution and
- (5) Variations in leaching requirements.

Variations in cropping patterns are due to many factors, but the main one is market prices. When cropping patterns change, farm water requirements change and this in turn might stress the water distribution system. Simulations with parameters obtained from observed data are a way of dealing with this. The details of this procedure will be given subsequently.

Variations in rainfall and evapotranspiration affect crop water requirements significantly. In order to analyze the effect of such variations on crop water requirements, it is useful to review the variations of the basic climatological variables that are needed for the determination of crop water requirements. The basic strategy to determine the crop water requirement over a physically suitable interval is to evaluate the cumulative evapotranspiration of the plant over this interval. Adjustments due to rainfall and soil moisture depletion could be made by studying the soil water balance of the root zone. Realizing that potential evapotranspiration is basic for the evapotranspiration computations, it is the variation in potential evapotranspiration that will be of interest here.

4.3.2 Random Variation In Evapotranspiration Due To Climatological Factors

Random variations in evapotranspiration of a given field crop could arise due to the following:

- (1) Random variations in cloud cover (radiation),
- (2) Random variation in the temperatures of air and the crop,
- (3) Random variations in wind velocities and
- (4) Random variations in the relative humidity.

Of the factors that influence evapotranspiration any could be critical (McCuen (1974)) depending on the location. The sensitivity depends also on the method used to compute evapotranspiration. Within the potential error in the

measurements of climatological factors that are needed for the computation of evapotranspiration, for the locations studied by McCuen (1974), the total error did not exceed 5% of the final daily value. In general, McCuen (1974) observed that in coastal areas humidity might be more influential than the other factors and in arid regions temperature might influence the evapotranspiration most. In arid regions, wind speed might have more of an effect on evaporation than in humid regions. These views however, might not be generally accepted (Boonyatharakol (1979), Davenport (1967)). Thus, to analyze the variations of evapotranspiration, the fluctuations in the climatological factors should be studied.

4.3.3 Random Variations In Net Radiation

Radiation data, original or synthesized, are required for the Penman's method and the other radiation methods which are popular. Since net radiation is a function of incoming radiation, the albedo, the cloud cover and the out going radiation which in turn is a function of cloud cover, the air temperature and the vapor pressure, the analysis of fluctuations of the net radiation becomes complex. Van Bavel (1966) found that using 24 hour averages for air temperature, vapor pressure and wind speed in the modified Penman's Equation gave satisfactory results for daily evapotranspiration values on mostly clear days. For daily computations using Penman's Equation, Jensen et. al. (1970) used daily means for air temperature. Davenport (1967) prescribed maximum temperature to be used in a linear regression of the evapotranspiration with the climatological factors and found good correlation. This might have been due to similar temperature distributions over the days of measurement. Boonyatharakol (1979) also used daily average values in

Penman's Equation for the parameters and obtained good results. In radiation methods expressing potential evapotranspiration as (Doorenbos and Pruitt (1975)),

$$ET_p = a_o + b_o W \cdot R_s \quad (4.3.1)$$

where, a_o and b_o are constants, W a function of temperature and altitude and R_s is the incoming (short wave) solar radiation, the daily average values are used. The modified Jensen and Haise method (1963) also used daily means to compute the daily evapotranspiration. Thus, for the computation of daily evapotranspiration, the basic variables will be ascribed their daily mean values in this study. The daily insolation has been measured by many researchers (see Doorenbos and Pruitt (1975)) and the expression for total incoming radiation is given as:

$$(a+b (n/N)) R_A \quad (4.32)$$

where a , b are regression constants, n the number of actual sunshine hours, N the number possible sunshine hours and R_A the extraterrestrial incoming radiation. Doorenbos and Pruitt (1975) have given the values for a and b for many different latitudes. On an average $a = .25$ and $b = 0.50$ may be used. R_A and N also could be found in Doorenbos and Pruitt (1975) for many different latitudes. When n/N data is not available, they have given n/N values on the basis of cloudiness, which is not supposed to be very accurate.

Lof et.al. (1966) have also derived regression coefficient in Equation (4.3.2) for many different locations in the world. In contrast to the a and b values of Doorenbos and Pruitt, the corresponding values of Lof et.al. (1966) for a and b are .388 and .376 respectively. Lof et. al. (1966) also gave contour maps on a

monthly basis for the daily means of total incoming solar radiation in a world map. Swartman and Ogunlade (1967) showed, using data from Ibadan, Nigeria that in fact R_s is better correlated as

$$R_s = R_s(S, R_H) \quad (4.3.3)$$

where R_H is the relative humidity. However, for the data they were reporting, the error caused by using a single linear equation of the form (4.3.2) is about 5% more than for the case of using a linear form of Equation 4.3.3. The linear regression of R_s only with S underpredicted the radiation in one of the stations studied by Swartman and Ogunlade (1967). Overprediction occurred for the other two cases. They also stated that the measuring techniques were such that the measured values tended to be on the low side. Thus, the linear regression of the type given by Equation (4.3.2) might be off by about $\pm 10\%$ which in turn would affect the final values of potential evapotranspiration by about $\pm 5\%$. While it is preferable to develop regression relations using S and R_H , the use of simple linear regressions of the type given by Equation (4.3.2) is followed in this study.

Since R_A may be considered non-random and a and b are constant coefficients, randomness occurs in R_s due to randomness in the cloud cover. If cloud cover data are not available but incident radiation, R_s , on a monthly basis is, then the method proposed by Liu and Jordan (1960) might be used to find the percentage of the time the ratio, K , of daily solar radiation received to the extraterrestrial radiation would be less than a prescribed value. The ratio, K , mentioned above is called as clearness index and Biga and Rosa (1981) expanded the probability distribution studies of K (of Liu and Jordan (1960)) using data from Lisbon, Portugal. Biga and Rosa (1981) found distributions for K for the number of days of study N , equal to 1, 5 and 15. For the case of $N = 1$ their studies agreed with that of Liu and Jordan (1960).

Bendt et. al. (1981) have given a theoretical distribution for the fraction $f(K_0)$ of the time the clearness index, K , will be less than a prescribed value, K_0 , as follows:

$$f(K_0) = \frac{\exp(\gamma K_{\min}) - \exp(\gamma K_0)}{\exp(\gamma K_{\min}) - \exp(\gamma K_{\max})} \quad (4.3.4)$$

where, γ is to be obtained from:

$$\bar{K} = \frac{\left(K_{\min} - \frac{1}{\gamma}\right) \exp(\gamma K_{\min}) - \left(K_{\max} - \frac{1}{\gamma}\right) \exp(\gamma K_{\max})}{\exp \gamma K_{\min} - \exp \gamma K_{\max}} \quad (4.3.5)$$

$$\bar{K} = \frac{\bar{R}_s}{R_A} \quad (\text{on monthly basis}) \quad (4.3.6)$$

The distribution $f(K_0)$, is exponential as are the popular rainfall models (See Todorovic and Woolhiser (1974) and Richardson (1981)) and there must be good correlation between the rainfall and cloud cover processes. If such a correlation function is found at least on a monthly basis, then this will facilitate the computation of R_s at locations where only rainfall records are available.

In this study we pursue the computation of available incident solar radiation using the tables of R_A given in Jensen (1973) or Doorenbos and Pruitt (1975) and using monthly average values of (n/N) adjusted for daily values using Liu and Jordan (1960) curves at a desired fractional level (of time of getting less than the K value). For higher reliability this fractional level should be high.

The evaluation of albedo, α , is required for the evaluation of the net radiation. The general value of $\alpha = 0.23$ as prescribed by Jensen (1973) will

be used in this study. The general expected variation of α is .20 to .25 (Jensen (1973)) and is a function of the leaf area index, LAI.

The net outgoing (long wave) radiation by earth is also an important component in the study of net radiation received by a field of crops. The outgoing radiation is also referred to as terrestrial radiation, terrestrial emissive power and terrestrial radiant self exitance. This radiant self exitance, R_b is also a function of cloud cover. The self exitance on a clear day, R_{bo} , is often regressed with R_b in the form:

$$R_b = (a_1 (R_s/R_A) + b_1) R_{bo} \quad (4.3.7)$$

where a_1 and b_1 are empirical coefficients. a_1 and b_1 in general are equal to 1.2 and -0.2 (Jensen (1973), page 27). We might adapt the K values for daily computations and write Equation 4.3.7 as:

$$R_b = (a_1 K + b_1) R_{bo} \quad (4.3.8)$$

The clear day self exitance R_{bo} is a function of the average daily temperature and the emissivity of the surface. R_{bo} is given by the following equation:

$$R_{bo} = \epsilon \sigma T^4 \quad (4.3.9)$$

where T is the average daily temperature in degree K, ϵ the emissivity of the field and σ the Stefan - Boltzman Constant. At screen level the Idso and Jackson (1969) formula is considered to give the best ϵ value (Boonyatharakol (1979)) and is given by:

$$\epsilon_s = 1 - 0.261 \exp (7.77 \times 10^{-4} (273 - T)^2) \quad (4.3.10)$$

where ϵ_s is the screen level emissivity.

Assuming the ground emissivity to be 0.98 (Jensen (1973)), the net emissivity ϵ of the field is given by:

$$\epsilon = .98 - \epsilon_s$$

$$\epsilon = - 0.02 + .261 \exp (7.77 \times 10^{-4} (273 - T)^2) \quad (4.3.11)$$

For R_{bo} in Cal/cm^2 (i.e. in langley (Ly)),

$$\sigma = 11.71 \times 10^{-8} \text{ cal/cm}^2 \text{ day}^{-1} \text{ } ^\circ\text{K}^{-4}$$

Once R_b is found the net radiation R_n is given by:

$$R_n = (1 - \alpha) R_s - R_b \quad (4.3.12)$$

Random Variations in Wind Velocity

Wind velocity affects evapotranspiration in a more pronounced manner in arid regions than it does in humid regions (McCuen (1974)). However, wind is least sensitive factor in twelve of the thirteen locations studied by McCuen (1974). Also, in available popular meteorological synopses (see Rudloff (1981) and W.M.O. (1965)) either wind data are not given or are available only for relatively shorter periods. Thus, it may be preferable to use the monthly average values available at a station suitably modified for other lengths of time.

Random Variations in Temperature

In general evapotranspiration models, especially, that based on Penman's approach are sensitive to the temperature (see Coleman and DeCoursey (1976) and McCuen (1974)). Depending on location, the standard deviation of the daily mean temperature might vary and could be considerable (for instance, see Richardson (1981)). Also, the temperature would be a function of altitude of the project area and might not be correlated with the amount of solar radiation received.

Random Variations in Relative Humidity

Even though relative humidity is important for evapotranspiration computations, especially for coastal areas (McCuen (1974)), information on its variation is not generally available.

Summarily, even though random variation in the climatological factors that influence potential evapotranspiration are expected, we might, following Burt et. al. (1981), use monthly average data for the computations even for intervals shorter than a month smoothing the monthly values over the whole year.

4.3.4 Variations in Cropping Schedules (Temporal)

In many irrigation areas, farmers use the available precipitation for land preparation purposes at least to an appreciable extent and to some extent for the plant growth. Some system designs attempt to schedule the crop growth stages to make the most out of the available precipitation (see Thavaraj (1979)). Also, cropping schedules within an area vary (see Dad (1982)). Reasons for the variation could be many, the main reason often is the availability of equipment and labor. The previous experience of the farmers as regards the pattern of water receipts could also be a factor.

In a well coordinated project, such variations are expected to be minimal. Nevertheless, such variations should be parameterized and incorporated in the design procedures. Mean and variance of the parameters affecting the beginning date of cultivation has to be observed and distributions have to be obtained. In this case a given percentile date (i.e. the date at which at least the given percentile of the farmers begin their cultivation) can then be arrived from which subsequent calculations could proceed.

4.3.5 Farmer Readiness Model

Suppose, when previously announced that the N_R th day of the Julian calendar would be the day that the farmers in a turnout area would begin to receive water, the statistical distribution of a farmer's readiness is parameterized by $\mu = \mu_0$ and $\sigma = \sigma_0$. Assuming independence of

farmer readiness within a turnout area, the joint distribution for the day of readiness of farmers within a turnout area is given by:

$$f(x_{R_1}, x_{R_2}, x_{R_3}, \dots, x_{R_n}) = \prod_{i=1}^n h(x_{R_i}, \mu_0, \sigma_0) \quad (4.3.13)$$

where x_{R_i} is the day the i th farmer is ready to receive water and $h(x_{R_i}, \mu_0, \sigma_0)$ is the distribution of the individual farmer readiness with the parameters, μ_0 and σ_0 . Many different scenarios have to be envisioned before the distribution $h(x_{R_i}, \mu_0, \sigma_0)$ is developed. They are:

1. Systems in which land is prepared using the antecedent soil moisture and water releases begin for planting (seeds or seedlings) or irrigation of the crops,
2. Systems in which water has to be released for land preparation from which point water releases for crop growth follow (Ponrajah (1981)) and
3. Systems in which water will be needed initially only for the nurseries and in the meanwhile land preparation goes on until the crops are ready for transplantation from which point water releases for crop growth are needed (Oad (1982)).

In some systems these distinctions would not be clear cut (Bagadion et. al. (1976)). In systems 1 and 2 mentioned above, the farmer readiness to receive water for land preparation, planting of the crops or irrigation of the crops is more critical than in system 3, in which, farmers' readiness is expected only to receive water for the nurseries. Whereas in System 1, randomness is expected on the day the farmer is to begin receiving the water, and in systems 2 and 3 randomness is expected in farmer readiness on the days of water release for land preparation. This in turn affects the length of the land preparation

period. Crop growth periods should conform to the climatological patterns. Thus, in our turnout area water requirement modeling considering all kinds of systems, we will concern ourselves about the farmer readiness to receive water soon after transplanting or planting the seeds. Suppose a farmer needs n_{lp} days to prepare his land with the normal amount of labor and equipment available to him. Suppose the availability of labor and equipment to him on all of the days is uniform, independent of the days and is with a probability, p_l . The probability that he will be ready by day, X_{ri} , is given by the sum of the basic negative binomial distribution as follows:

$$h(x_{Ri}, \mu_o, \sigma_o) = \sum_{k=n_{lp}}^{x_{ri}} \binom{k-1}{n_{lp}-1} p_l^{n_{lp}} (1-p_l)^{k-n_{lp}} \quad (4.3.14)$$

Assuming independence of events the probability that all farmers will be ready by day x_R is given by

$$f(x_R, x_R, \dots, x_R) = \prod_{i=1}^n [h(x_R, \mu_o, \sigma_o)]^n \quad (4.3.15)$$

Tables 4.3.1 through 4.3.5 give the values of X_R at which 90% farmer readiness is expected with parameters n_{lp} , p_l , and n as given.

4.3.6 Variations in Groundwater Contributions to Water Requirements

Ground water contributions to water requirements can be at various time scales, in the sense that a crop area in a project could get ground water contributions say at the very beginning of the project, or after some time when deep percolation has built up the water table with conditions existing for such ground water movement. Doorenbos and Pruitt (1977) have given the ground water contributions to the moist root zone for various soil types as functions of water table depth. Doorenbos and Pruitt (1977) also have given

the minimum distance of ground water table below the rooting depth as follows:

- | | | |
|-------|------|--------|
| (i) | Sand | 20 cms |
| (ii) | Clay | 40 cms |
| (iii) | Loam | 80 cms |

Burt et. al. (1981) have adopted this approach in their crop water requirement model.

In a design process, for the cases where water table is relatively higher, the build up of water table in relatively a short time needs to be studied. Also, it may be necessary to incorporate a drainage system for such cases. The water table movement is a function of the deep percolation losses within the crop area. In an area which has reached a dynamic equilibrium in its ground water movement with the rainfall recharge events, when irrigation activity begins, change in water table position is expected. If the boundary conditions are not suitable for this extra bank storage to dissipate, water table build up is expected. The recharge due to irrigation depends primarily on the amount of deep percolation. Thus, the ground water contribution could be studied only in an iterative manner given the present state of the art of crop water requirements computations.

4.3.7 Net Potential Crop Water Requirement Computer Code

With the data available as to the farmer readiness also as an input, a computer code (TANWARM) was developed to generate the potential crop water requirement at given intervals of time beginning from the day at which the farmers would be ready at a given probability level. TANWARM has two subroutines to compute the potential evapotranspiration; one using the modified Penman approach and the other using the modified Jensen and Haise approach. It uses monthly average of data for the parameters such as

TABLE 4.3.1

Variation of Farmer Readiness with Labor
and Equipment Availability.

Number of Farmers in the Turnout Area = 20

Average Number of Days Taken by a Farmer
to Prepare the Land = NLP

Probability of labor & Equipment Availability	Day by which Farmers are ready at 90% Probability level (Rounded)					
	NLP (Days)					
	10	12	14	16	18	20
0.75	20	23	26	30	-	-
0.80	18	21	24	27	30	-
0.85	16	19	22	25	27	30
0.90	15	17	20	22	25	27
0.95	13	15	18	20	22	25

TABLE 4.3.2

Variation of Farmer Readiness with Labor
and Equipment Availability.

Number of Farmers in the Turnout Area = 25

Average Number of Days Taken by a Farmer

To Prepare the Land = NLP

Probability of labor & Equipment Availability	Day by which Farmers are ready at 90% Probability level (Rounded)					
	NLP (Days)					
	10	12	14	16	18	20
0.75	20	24	27	30	-	-
0.80	18	21	24	27	30	-
0.85	17	19	22	25	27	30
0.90	15	18	20	22	25	27
0.95	13	16	18	20	22	25

TABLE 4.3.3

Variation of Farmer Readiness with Labor
and Equipment Availability.

Number of Farmers in the Turnout Area = 30

Average Number of Days Taken by a Farmer
to Prepare the Land = NLP

Probability of labor & Equipment Availability	Day by which Farmers are ready at 90% Probability level (Rounded)					
	NLP (Days)					
	10	12	14	16	18	20
0.75	21	24	27	30	-	-
0.80	19	22	25	27	30	-
0.85	17	20	22	25	27	30
0.90	15	18	20	23	25	28
0.95	13	16	18	20	23	25

TABLE 4.3.4

Variation of Farmer Readiness with Labor
and Equipment Availability.

Number of Farmers in the Turnout Area = 35
Average Number of Days Taken by a Farmer
to Prepare the Land = NLP

Probability of labor & Equipment Availability	Day by which Farmers are ready at 90% Probability level (Rounded)					
	NLP (Days)					
	10	12	14	16	18	20
0.75	21	24	27	30	-	-
0.80	19	22	25	28	30	-
0.85	17	20	22	25	28	30
0.90	15	18	20	23	25	28
0.95	14	16	18	20	23	25

TABLE 4.3.5

Variation of Farmer Readiness with Labor
and Equipment Availability.

Number of Farmers in the Turnout Area = 40

Average Number of Days Taken by a Farmer
to Prepare the Land = NLP

Probability of labor & Equipment Availability	Day by which Farmers are ready at 90% Probability level (Rounded)					
	NLP (Days)					
	12	14	16	18	20	22
0.75	21	24	27	30	-	-
0.80	19	22	25	28	-	-
0.85	17	20	23	25	28	30
0.90	15	18	20	23	25	28
0.95	14	16	18	20	23	25

radiation temperature, etc. Using spline functions, the daily values of the parameters are found and used to generate the daily evapotranspiration from which the net water requirements at any given interval is computed. Tables (4.3.6) to (4.3.8) give the values of water requirements at 5 day intervals for three different crops; corn, cotton and rice for conditions similar to Egypt using the modified Penman method. TANWARM also receives input as to the respective fractions of an area which are irrigated with different crops.

4.4 TURNOUT AREA DEPTH REQUIREMENTS

4.4.1 Seasonal Scheduling Using Production Functions

It was seen previously as to how the net turnout area potential water requirements might be obtained using an evapotranspiration model and a farmer readiness model. Since deep percolation depends on the on-farm application system dynamics and the amount of water applied, the ground water interaction could be studied only in an iterative manner. In this section we will concern ourselves about the optimal irrigation interval, the associated on farm system variables and finally the ground water interaction.

Hall and Buras (1961) studied how a set of fields of farms growing different crops could be allocated water under bounding conditions of water supply using the dynamic programming approach. This approach assumed the returns from a field to be simple functions of total seasonal allocations of water to it. Hall and Butcher (1968) subsequently studied the problem of optimal timing of irrigation using a multiplicative production function of the following type:

$$y_r = \prod_{i=1}^n a_i(w_i) \quad (4.4.1)$$

where y_r is the relative yield (ratio of actual yield to the potential yield), w_i the soil moisture at the end of the i th period, n the total number of

TABLE 4.3.6

UNSTRESSED CROP WATER REQUIREMENTS
FOR CORN

DAY NUMBER	REQUIREMENT (mm)
135	15.18
140	15.91
145	17.03
150	18.70
160	23.25
165	26.71
170	31.65
175	38.26
180	45.50
185	51.91
190	56.15
195	57.76
200	57.34
205	55.70
210	53.41
215	50.86
220	48.06
225	44.95
230	41.55
235	37.89
240	34.05
245	30.10
250	26.10
255	23.35

TABLE 4.3.7

UNSTRESSED CROP WATER REQUIREMENTS
FOR UPLAND RICE

DAY NUMBER	REQUIREMENT (mm)
152	57.58
157	57.73
162	57.58
167	57.13
172	56.46
177	55.71
182	54.98
187	54.40
192	54.05
197	54.00
202	54.09
207	54.07
212	53.72
217	52.85
222	51.30
227	48.95
232	45.94
237	42.62
242	39.30
247	36.25
252	33.70
257	31.84
262	30.67
267	29.95

TABLE 4.3.8

UNSTRESSED CROP WATER REQUIREMENTS
FOR COTTON

DAY NUMBER	REQUIREMENT (mm)
90	12.31
95	13.00
100	23.48
105	13.63
110	13.82
115	14.84
120	17.51
125	21.85
130	27.05
135	32.14
140	36.81
145	41.31
150	45.93
155	50.51
160	54.57
165	57.65
170	59.63
175	60.64
180	60.83
185	60.38
190	59.44
195	58.23
200	56.98
205	55.92
210	55.18
215	54.48
220	53.19
225	50.76
230	46.80
235	41.62
240	35.95
245	30.48
250	25.76
255	22.28
260	20.27
265	19.41
270	19.24
275	19.34
280	19.32

irrigations and a_i (w_i) the yield function corresponding to stage i . This formulation was precursory to the subsequent development of multiplicative production functions (Jensen (1968), Neghassi (1974) and Blank (1975), to quote a few).

Blank (1975) also gave an additive type model (based on Jensen's (1968) model for indeterminate crops) for corn in the form:

$$y_r = A_0 + \sum_{i=1}^n A_i (ET/ET_{\max})_i \quad (4.4.2)$$

where A_i are regression constants, $(ET/ET_{\max})_i$ is the ratio of actual evapotranspiration to the maximum and n is the number of stages of growth. All these developments, as are many others, are for specific crops mainly corn.

Yaron (1971) gave expressions of the type

$$y = a_0 + \sum_{i=1}^n a_i x^i \quad \text{where } n = 2 \text{ or } 3. \quad (4.4.3)$$

for the yield y of grain sorghum as a function of effective quantity of water applied during a season of growth.

Reddy (1980) related the relative yield for wheat with the irrigation system performance at each irrigation during the season in the following manner:

$$y_r = a + bE_r + cE_r^2 \quad (4.4.4)$$

where E_r is the requirement efficiency of the irrigation and where a , b and c are coefficients.

Nairizi and Ryzewski (1977) compiled and presented yield functions as sensitivity index functions for a variety of crops. This development not only helps to find the most critical stage of growth of a crop, as regards moisture

stress, but gives also the relative yields. The analyses of these authors are based upon the multiplicative type production functions

$$y_r = \prod_{i=1}^n (W_a/W_o)_i^{\lambda_i} \quad (4.4.5)$$

where W_a is the net water application, W_o is the crop water case when the soil water is not limiting, λ_i an index referring to the sensitivity of the crop to the stage, i , of its growth and n the number of stages. Nairizi and Rydzewski (1977), of course, assumed that the net water applications were equal to the crop water use during the i th stage. Interpreting Equation (4.5) in the manner of Jensen (1968)

$$(W_a/W_o)_i = (ET/ET_{\max})_i \quad (4.4.5)$$

The expressions of Nairizi and Rydzewski (1977) could be generalized as

$$y_r = \prod_{i=1}^n (ET/ET_{\max})_i^{\lambda_i} \quad (4.4.7)$$

where

$$\lambda_i = D/I \sum_{j=0}^{NCC} a_j (100D_i/D_{CG})^j$$

where NCC is an integer that depends on the crop, D_i is the day of the middle of stage, i , and D_{CG} is the stage duration (days) and I the irrigation interval. Nairizi and Rydzewski (1977) have given the factors, a_j and N_{CC} for a variety of crops.

If the irrigation interval is N_{dt} (days), it may be approximated that

$$(ET/ET_{\max})_i = 1/m \sum_{j=1}^m (K_a)_j \quad (4.4.8)$$

where $(K_a)_j$ is the moisture stress coefficient on the j th day and $m = N_i/N_{dt}$ where N_i is the number of days in stage i . Using the modified linear expression mentioned previously

$$K_a = 1/b [D_t - D_p / D_t]; K_a \leq 1 \quad (4.4.9)$$

From the above formulation it may be seen that for maximum yield we should set $K_a = 1$,

i.e.

$$D_p \leq (1-b) D_t$$

However, the supply corresponding to this depletion might not be optimal in the sense of maximization of net benefits from the irrigation area, since, by operating at higher amounts of depletion one might be able to irrigate more extent of land and obtain more benefits. Also, under deficient conditions of water supply, to irrigate a given extent of crops, higher depletions might be allowed (Sagardoy et.al. (1982)). Thus, the problem of optimal irrigation interval has to be studied under two conditions, viz,

- (1) Depletions that retain $K_a = 1$ and;
- (2) depletions that result in $K_a < 1$.

4.4.2 Case Of Depletions That Retain $K_a = 1$ (sufficient water supply case)

Let the irrigation interval at stage, i , that is to be found is $(N_{dt})_i$. In this case $(N_{dt})_i$ is given by

$$\sum_{j=1}^{(N_{dt})_i} (ET_{\max})_j = (D^*_p)_i \quad \text{and} \quad (4.4.10)$$

$$(D^*_p)_i \leq (1-b) (D_t)_i = (1-b) c \bar{r}_i \quad (4.4.11)$$

where c = the total available water, $(D_p^*)_i$ the depletion during stage i and r_i = average rooting depth in units of ET_{max} . The rooting depth, r_i is given by the relationship (Burt et.al. (1981))

$$\bar{r}_i = .15 + B D_i \quad (4.4.12)$$

where D_i is the degree day of the middle of stage i and B a constant. The value of B may be obtained from the maximum root depth (see Doorenbos and Pruitt (1977) page 88) for various crops and the number of days it takes to develop this depth. Here we might opt for three different water management strategies as follows: (see Sagardoy et.al. (1982))

- (i) Constant irrigation interval and a variable water supply;
- (ii) variable irrigation interval and a constant water supply and;
- (iii) variable irrigation interval and a variable water supply.

At the beginning stages the water requirements are low and in general the sensitivity is higher at more advanced stages. If an irrigation interval is found under strategy (i) it has to weigh more heavily the period of high moisture sensitivity and eventually will lead to closer intervals at the beginning stages which will in turn increase operational costs and more losses of water since any one irrigation event will be with efficiency less than unity. From a computational view point, strategy (ii) is a special case of strategy (iii). Sagardoy et.al. (1982) mention that even though such a strategy will result in use of crop water in the best manner, operationally such a system is vulnerable to malpractice since irrigation amounts vary from one irrigation to the next. However, if the variations are within bounds such a strategy might not be discounted at all. There is also another consideration that might disfavor the use of strategy (ii). If we compute the irrigation supply weighing the most sensitive moisture stress period, these amounts in the initial periods might not

be containable in the small root zone depths during the initial periods. In general, therefore, we will concern ourselves about strategy (iii). If irrigation interval and the amounts are to be varied, criteria should be given as a basis for their determination. A valid criterion would be to maximize the net benefits of an irrigation project.

Multicrop Irrigation Scheduling

In this case let the number of crop be N_c and the fraction of the extent of crop with index i be A_i . Let the crop growth duration for crop i be g_i and the beginning time (day) of planting be p_i . Dividing each crop growth duration into n_s stages in which root development peaks it is possible to obtain the root depths, \bar{d}_{ij} , of crop, i , during stage, j . Please see Figure (4.4.1). The average root depth for the turnout area, d_k , on day k could be found from the formula

$$\bar{d}_k = \sum_{i=1}^{N_c} A_i (d_k)_i \quad (4.4.13)$$

where $(d_k)_i$ is the root depth of crop i on day k . From a plot of \bar{d}_k with k , we will be further able to identify stages during which average root depths may be conveniently divided. If the number of such stages is N_c , and if there are n_ℓ days in stage ℓ , the irrigation interval, $n_{\ell i}$, during the stage ℓ is given by

$$n_{\ell i} = n_\ell \bar{d}_\ell (1-b) c / \sum_{i=1}^{n_\ell} (ET_{\rho_i}) \quad (4.4.14)$$

where \bar{d}_ℓ is the average root depth during stage ℓ . For single crop areas the

\bar{d}_ℓ is simply the root depth during stage ℓ .

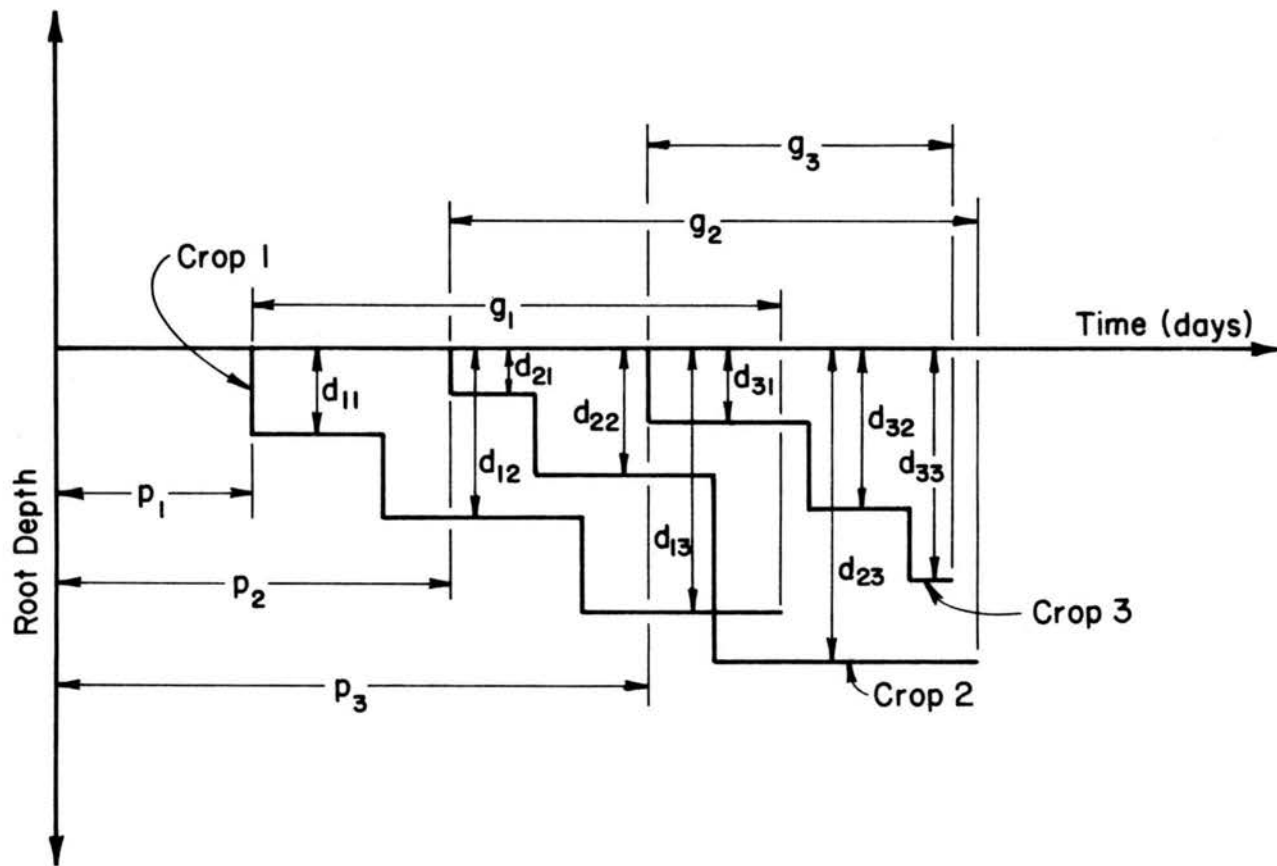

Fig. 4.4.1 Root Depths For Crops During A Growing Season

For the case of corn grown in Egypt the stagewise requirements using net water requirement data generated using the program TANWARM with the modified Penman's approach, are given in Table (4.4.1) (Data from Doorenbos and Pruitt (1977)).

For this set of computations,

$$C = \gamma_b (FC - PWP) b \quad (4.4.15)$$

Using Boonyatharakol's expression for b given by Equation (4.2.23)

$$C = \gamma_b (FC - PWP) [0.4229 + 0.1572R_o - 0.00790 (K_{sat}/T) + 0.0006 (K_{sat}/T)^2] \quad (4.4.16)$$

In the absence of data, $b = 0.548$, is used as suggested by Boonyatharakol (1979).

Taking the total available water (see Hart (1975), page 1-3) for the condition of medium soils (see Doorenbos and Pruitt (1977) page 56) $C = 0.15$ cm/cm, the irrigation intervals may be adjusted to give a certain number of irrigations within a stage. In the example case, setting in the first stage, two irrigations, in the second, three, in the third, four, and in the fourth, two. The scheduled depths are given in Table (4.4.2).

The Effect Of Rainfall

For best results accounting for the rainfall receivable by an irrigation area during a crop growing season must be done preferably at each of the irrigations planned. This calls for precipitation data and its analysis during the crop growing season. The analyses presented by Doorenbos and Pruitt (1977) and Ponrajah (1981) are on the basis of monthly rainfall. Since within the month, rainfall distribution is not accounted on such approaches, a general reduction in the requirements during a month might result in stressing of the crop in that period of the growth stage of the crops. Thus, it is preferable to

TABLE 4.4.1
CUMULATIVE ET REQUIREMENTS FOR CORN

ℓ	n (days)	d (meters)	Cumulative ET (mms)	Calculated Irrigation Interval
1	20	0.42	66.83	9
2	35	1.10	238.03	11
3	40	1.50	424.25	10
4	30	1.50	192.08	16

TABLE 4.4.2
SCHEDULED DEPTHS FOR CORN

Month	Day Julian	Requirement Depths (mms)
May	135	31.09
	145	35.74
June	155	79.34
	167	79.34
	180	79.34
July	190	113.91
	200	113.06
	210	104.27
August	220	93.01
	230	113.39
September	245	78.60

study the rainfall patterns for shorter periods and deduct the infiltrated amounts due to rainfall at given probability levels. The suggested level of probability by Doorenbos and Pruitt (1977) and Ponrajah (1981) is about 75%. This probability level may have to be refined.

Eagleson (1978) and Todorovic and Woolhiser (1971) have given theoretical distributions of the amounts of rainfall during a given length of days. Since the model parameters have to be derived from the observed data, it is preferable to develop histograms using daily rainfall data for the irrigation intervals of concern and to obtain the rainfall amounts at the given probability level.

The rainfall amounts, thus obtained, have to be adjusted for their effectiveness in replenishing the soil moisture reservoir bounded by the root zone. For the example case, there is no rainfall and the irrigation requirements are as given in the Table(4.4.2).

Groundwater Contribution

The contributions of the groundwater to the root zone soil moisture could be given by (Gardner (1968))

$$\int_{z_2}^{z_1} dz = - \int_{\psi_2}^{\psi_1} (k/q+k) d\psi \quad (4.4.17)$$

where z is the depth, (+ ve downwards), ψ the matric soil water potential, k the unsaturated hydraulic conductivity and q the constant (assumed) upward flow. Subscripts 1 and 2 refer to the root depth and the water table depth respectively. The relationship between k and ψ may be given by (Gardner (1968))

$$k = K/L (\psi/b)^S + 1 \quad (4.4.18)$$

where K is the saturated hydraulic conductivity, b is the potential at which $k = K/2$ and s is a parameter that depends on soil. At instances of soil data not being available in this regard the relationship given by Doorenbos and Pruitt (1977) (page 76) could be used.

4.4.3 Case Of Deficient Water Supply

As has been observed already, two kinds of water supply deficiencies are to be analyzed. One is the case of the project design to stretch the acreage and possibly increase the net benefits by operating at $k_a \leq 1$ and the other case is that of water supply deficiency when the acreage has been fixed. The inputs regarding the operating depths could be given by the water resources discipline.

The models that have been developed hitherto obtain their basic elements from Hall and Buras (1961) approach for the spatial variation and Hall and Butcher (1968) approach for temporal variation in the water allocations. Dudley et.al. (1971) did a study of irrigation of a single crop (corn) in a stochastic setting using an additive type of sequential crop growth model. An important aspect of their study is the effect of terminal soil moisture on the analysis. Hiler and Howell (1974) also studied the irrigation of single crop (grain sorghum) in a stochastic setting. Windsor and Ven Te Chow (1971) studied the multi-crop problem in humid areas in a stochastic setting. They used a dynamic programming approach to separate the optimal seasonal outputs of the different crops under the given conditions of constraint and used linear programming to generate the optimal crop mix, the optimal irrigation decisions and also the optimal irrigation system. Windsor and Ven Te Chow (1971) did not take into consideration the dependence of the ratio, α , of actual to the potential evapotranspiration on the soil moisture status during any given stage. Thus, it becomes desirable to develop a model that is

more adaptable to the problem of system design and considers the soil moisture stress aspect more accurately. Production functions used herein are obtained from that given by Nairizi and Rydyewski (1976), though for other crops similar functions may be developed and used. Also a composite approach involving the system design variables (Reddy (1980), Reddy and Clyma (1980)) will be made subsequently. Since the spatial variation of system parameters are accounted for, the design variables are expected to vary from place to place within a project area.

Multi-Crop Case

Since crop growth periods are contained within given spans of time in a year, the problem of optimal allocation of water in both space and time may be analyzed by first proceeding in time and then in space.

Using the crop growth functions of multiplicative type (Nairizi and Rydzewski (1977)), the yield, Y_j , from a unit area in sub area j is given by

$$Y_j = \sum_{i=1}^{N_c} \pi_{k=1}^{n_i} (ET/ET_{\max})_{ik}^{\bar{\lambda}_{ik}} y_{mi} A_i \quad (4.4.19)$$

Using Nairizi and Rydzewski (1977) functions we write

$$\bar{\lambda}_{ik} = D/I \sum_{\ell=0}^{NCC_i} a_{\ell} (100D/D_{CGI})^{\ell} \quad (4.4.20)$$

where D the number of days at stage ℓ and is counted from the day the crop is planted. On counting the days on a uniform basis from N_R , the day the farmers are ready, and observing that

$$(ET_{\max})_{ik} = K_{aik} ,$$

$$Y_j = \sum_{i=1}^{N_c} \pi_{k=1}^{n_i} (K_{aik})^{\bar{\lambda}_{ik}} y_{mi} A_i \quad (4.4.21)$$

where

$$\bar{\lambda}_{ik} = D/I \sum_{l=0}^{NCCi} a_l \left(100 (\bar{D}_{il} - p_i) / D_{CGi} \right)^l, \quad (4.4.22)$$

where \bar{D}_i is the middle of stage of crop i and p_i the day crop i is planted, both counted from day N_R . This formulation allows for farmer strategizing to allocate the given water appropriately to the crop needs. In multi crop areas the farmer will show the tendency to weigh more the crops that might give more benefit. In a mathematical programming approach for the determination of K_{aik} , we need to consider an objective function. In the present case, it is appropriate to maximize the net benefits from a unit area. For this we need the net benefits of selling one unit of each of the crops. If the benefit is c_i and cost is d_i for crop i , then the objective function that needs to be maximized is

$$Y = \sum_{i=1}^{N_c} \left\{ \left[\sum_{k=1}^{n_i} \pi (K_{aik})^{\bar{\lambda}_{ik}} y_{mi} c_i \right] - d_i \right\} A_i \quad (4.4.23)$$

At this stage the application system optimality analysis of (Reddy (1980) and Reddy and Clyma (1980)) will not be attempted. We will find the depths at different irrigations that will optimize the net benefits for unit area and proceed for the case of spatial variation of system variables at which instance the system optimality will be analyzed.

The objective function has to be maximized subject to the total water availability constraint and with the stage equation for soil moisture balance (Hall and Butcher (1968)). Also, the K_{aik} values will be found for the whole

of the stage k from which water requirements will be found. Boonyatharakol's linear expression for K_a will be utilized. In this case

$$K_{aik} = 1/b_i [1 - D_{pk} / D_t] = 1/b_i \bar{\theta}_{ik} / \theta_{si}, K_{aik} \leq 1 \quad (4.4.24)$$

where $\bar{\theta}_k$ is the average soil moisture content at stage k and θ_s is that at field capacity.

Using the above expression in the objective function we have

$$\text{Max } Y = \sum_{i=1}^{N_c} \left[\prod_{i=1}^n (K_{aik})^{\bar{\lambda}_{ik}} y_{mi} c_i - d_i \right] A_i \quad (4.4.25)$$

S.t.

$$(i) \quad \sum_{i=1}^{N_c} A_i \theta_{in+1} = \sum_{i=1}^{N_c} A_i \theta_{in} + d_n - \sum_n (ET), \quad (4.4.26)$$

(n refers to the stages of irrigation and not growth stages)

$$(ii) \quad \theta_{wp} \leq \theta_{in} \leq \theta_s \quad \text{and} \quad (4.4.27)$$

where θ_{wp} corresponds to the wilting point (soil moisture content).

$$(iii) \quad \sum_{n=1}^{n_T} d_n \leq D_j \quad (4.4.28)$$

where D_j is the amount seasonally available for area j which is under consideration, n_T total stages studied and θ the average soil moisture content for the unit area.

The computational approach adopted for the solution of this optimization problem is as follows:

First, the functions

$$y_{si} = \prod_{k=1}^{n_i} (K_{aik})^{\lambda_{ik}} \quad \text{are maximized,} \quad (4.4.29)$$

S.t.

$$(i) \quad \theta_{ik+1} = \theta_{ik} + d_k - (e_{ik}) K_{aik} \quad (4.4.30)$$

where d_k is the amount of water applied and e_{ik} is the crop potential evapotranspiration during stage k .

$$(ii) \quad \theta_{wp} \leq \theta_{ik} \leq \theta_s \quad \text{and} \quad (4.4.31)$$

$$(iii) \quad \sum_{k=1}^{n_i} d_k = X_i$$

where X_i is the amount of seasonal water apportioned for crop i . By varying X_i , the optimal values of $y_{si} = y_{si}^*$ are found along with d_k^* for $k = 1, 2, \dots, n_i$.

In the second step

$$Y = \sum_{i=1}^{N_c} [y_{si}^*(X_i) y_{mi} C_i - d_c] A_i \quad \text{is maximized} \quad (4.4.32)$$

S.T.

$$\sum_{i=1}^{N_c} X_i \leq D_j \quad (4.4.34)$$

where D_j is the amount of total water available for distribution for area j as defined earlier. From the X^*_i , the optimal amount of water to be seasonally delivered to crop i will be found. The intraseasonal allocation will be found from the d^*_k corresponding to the X^*_i .

Since both the steps fit into the dynamic programming formulation, the computer code CSUDP available at Colorado State University was used. The problem in the first step involves two state equations and the CSUDP requires an initial trajectory for these state variables, the available water for irrigation and the soil moisture status. Appendix 4.1 gives the details of a procedure from which we would be able to find these trajectories and also find an approximate solution to step 1 of the composite objective function.

Single Crop Case

It is seen that in the above general approach we can obtain stagewise decisions for a single crop as a particular case.

4.5 APPLICATIONS OF MULTICROP IRRIGATION SCHEDULING MODEL

4.5.1 Generalities

As has been mentioned previously, K_{aik} is a function of the average soil moisture, $\bar{\theta}_{ik}$. Since the simple average of initial and final soil moisture values during a stage does not give reliable results when the number of stages is low, a procedure which is given in Appendix 4.2 was developed to obtain the average value of the soil moisture assuming frequent irrigation during any stage to reduce the inaccuracies. This model was applied for an area in Egypt growing cotton, maize and rice. The five day potential evapotranspiration using TANWARM for these crops obtained previously are used in the model. The Julian days at which farmers are ready in a turnout area for using the

water allocated are assumed as 90 for cotton, 135 for corn and 152 for rice. The fractional areas of unit land planted with each crop, benefit and cropping cost data are given in Table (4.5.1). The results of Step I, varying the seasonal water use for the three crops are given in Figures 4.5.1 to 4.5.6. The figures show how stagewise depths of irrigation should be in order to maximize yields.

In Step II computations, lower bounds were set for crop production which might arise due to farmers' personal choice or due to governmental stipulations. Two cases of cropping patterns were studied. Case 1 is the case of the areas being divided equally and Case 2 is a trial case of farmers' choice. As has been indicated already the areal extent of any particular crop is an economist's input and would not be dealt with. The results of the study of both the cases are given in Tables (4.5.2) and (4.5.3).

The results for Case 1 (equal fractional areas) are simplistic in the sense that priority in allocation is given to the crop that gives the best net return (cotton), then to the crop that gives the second best net return (corn) and lastly for the crop with the least net return (rice). The results for Case 2 indicate that the crop with maximum return (cotton) is given priority and the allocation amongst the other two crops does not follow simple rules though a prioritizing on the basis of net benefits could be seen.

It is important to indicate the sensitivity of the errors in the total net benefits caused by errors in the estimation of crop areas. Table (4.5.4) gives the results of this study for the case of assuming equal fractional areas whereas the real fractional areas are as in Case 2. We will examine two situations in this study. Since the water required for cotton (and corn for the cases where available water is greater than 880 mm/ha) is actually lower than the amount that is being allocated, we might study the following situations:

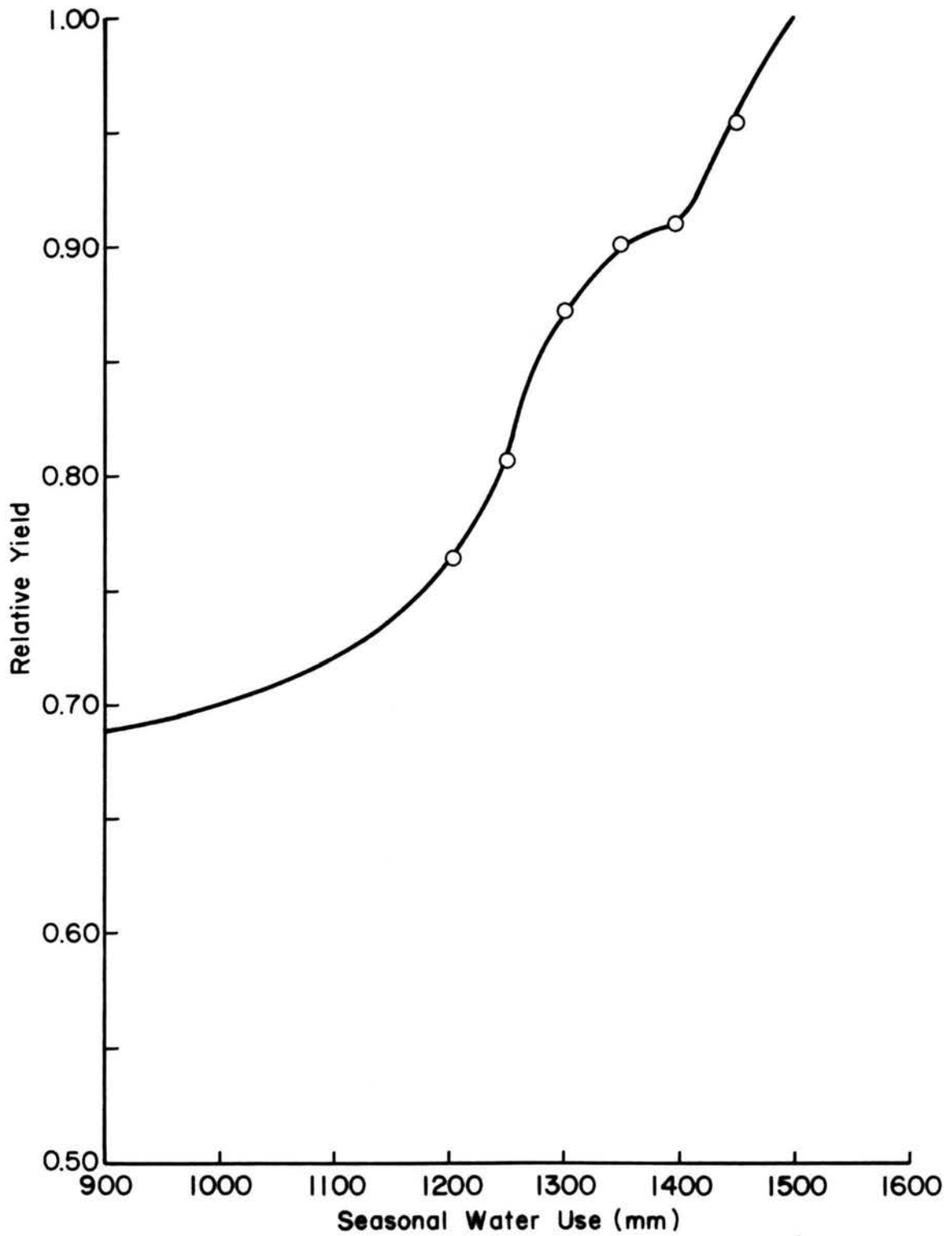

Figure 4.5.1 Yield vs Seasonal Water Use For Cotton

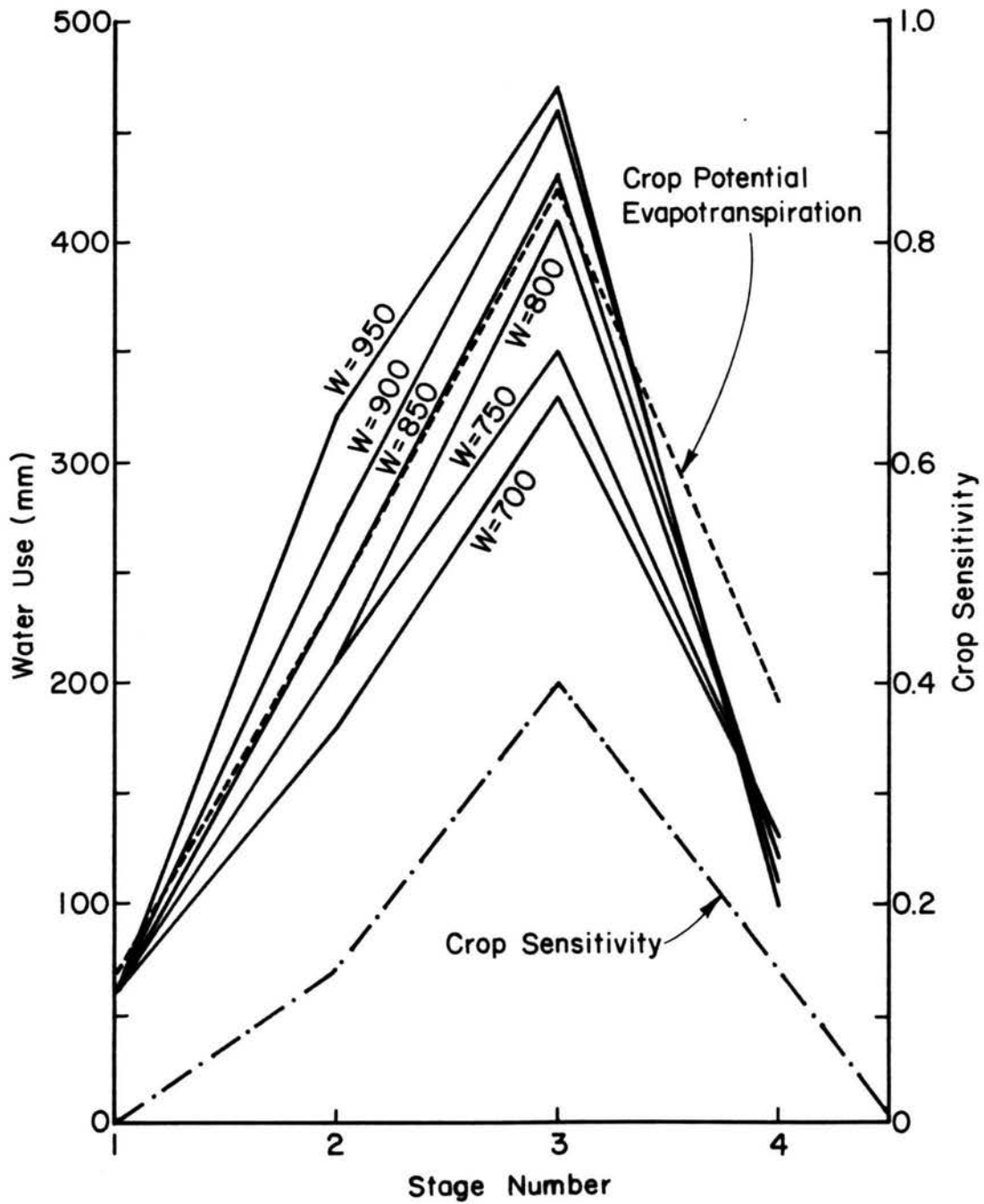

Figure 4.5.2 Optimal Irrigation Policies For Cotton

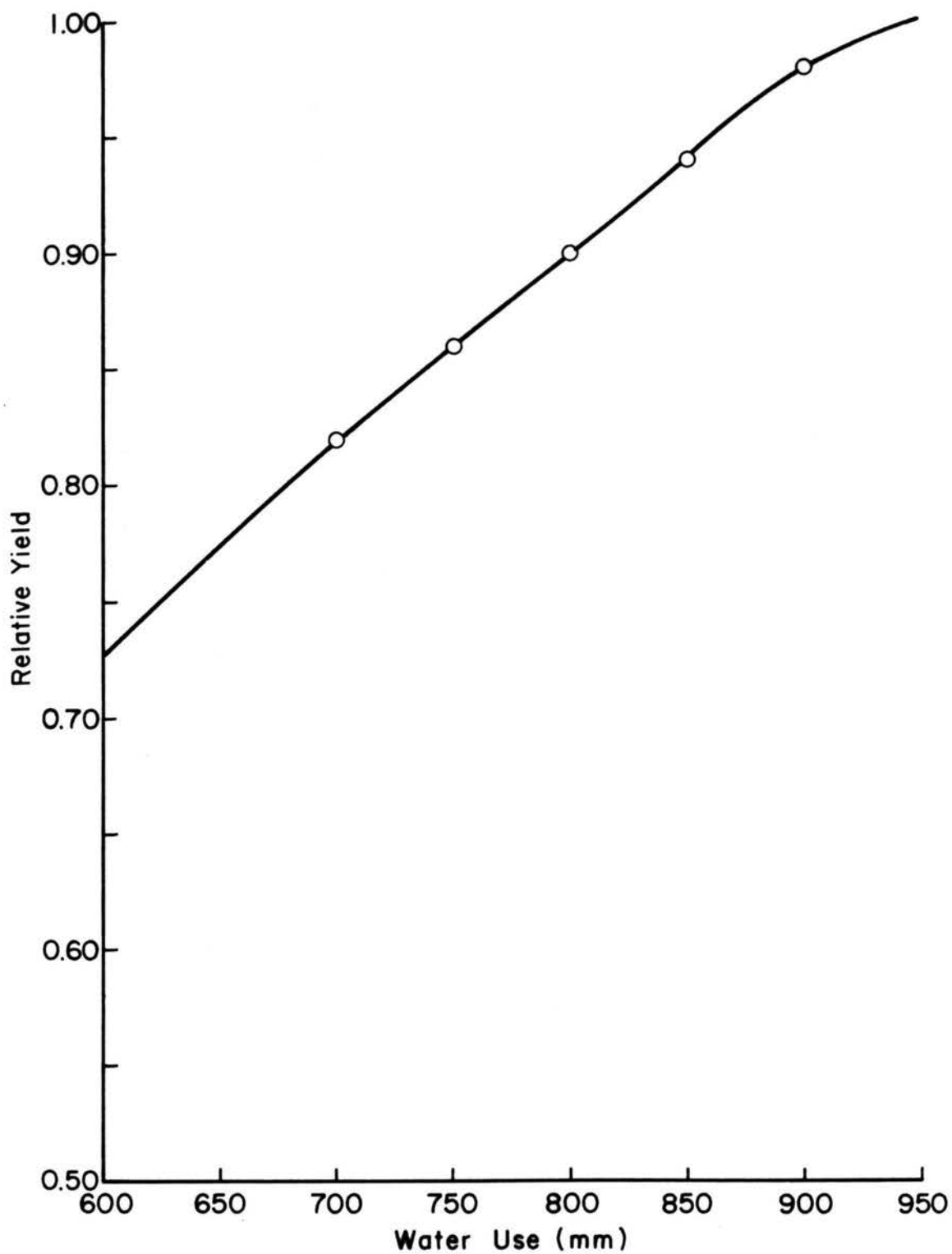

Figure 4.5.3 Yield vs Seasonal Water Use For Corn

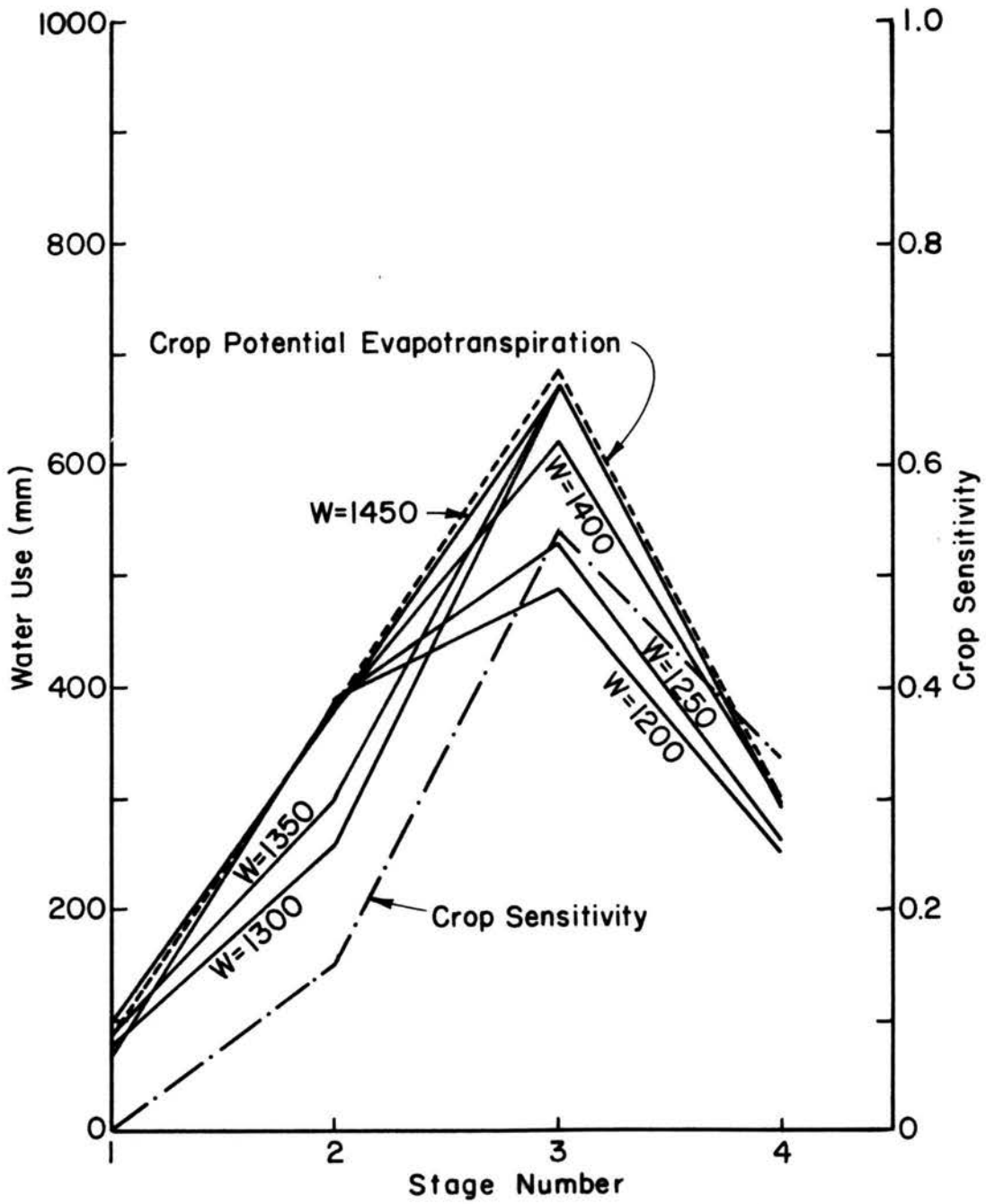

Figure 4.5.4 Optimal Irrigation Policies For Corn

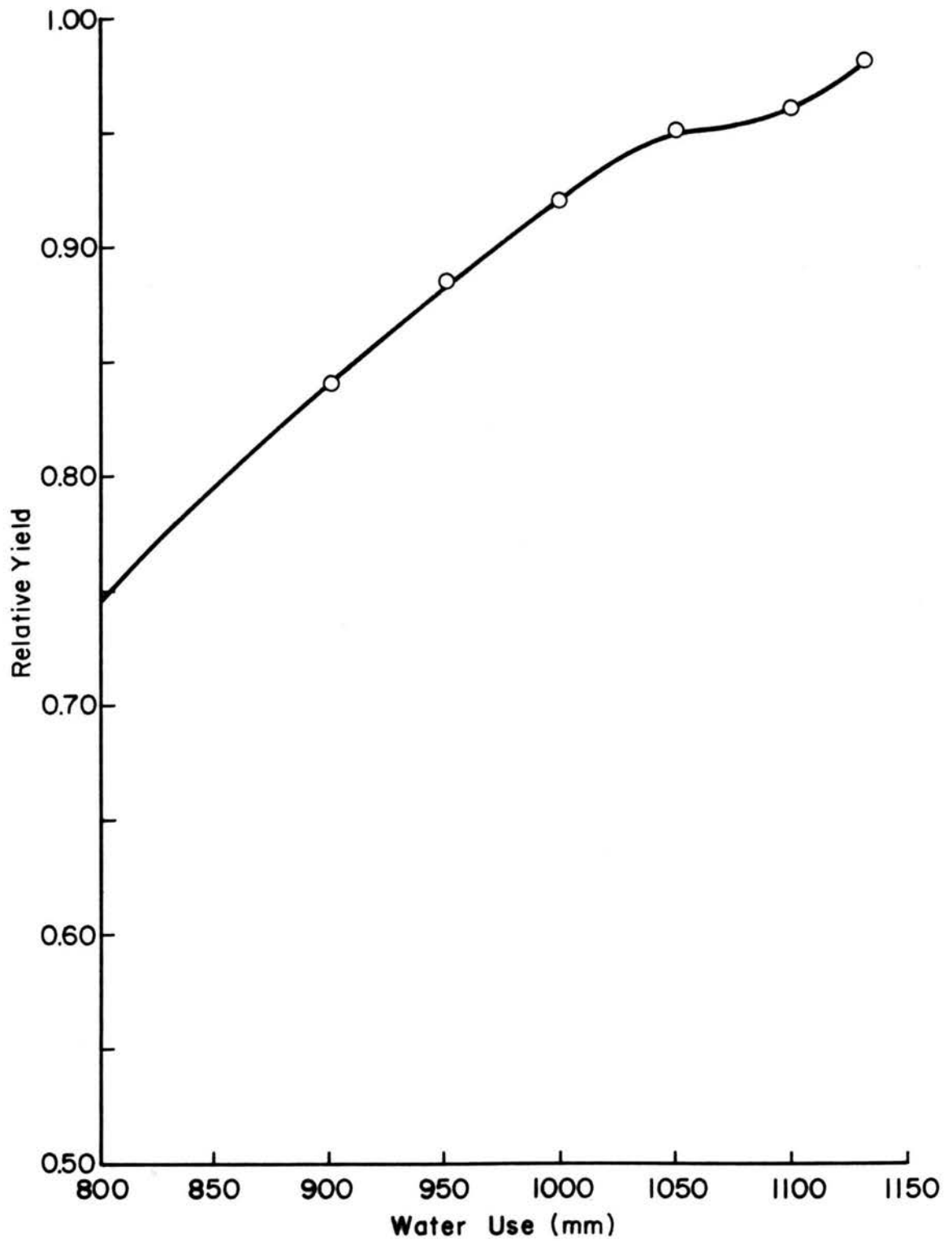

Figure 4.5.5 Yield vs Seasonal Water Use For Upland Rice

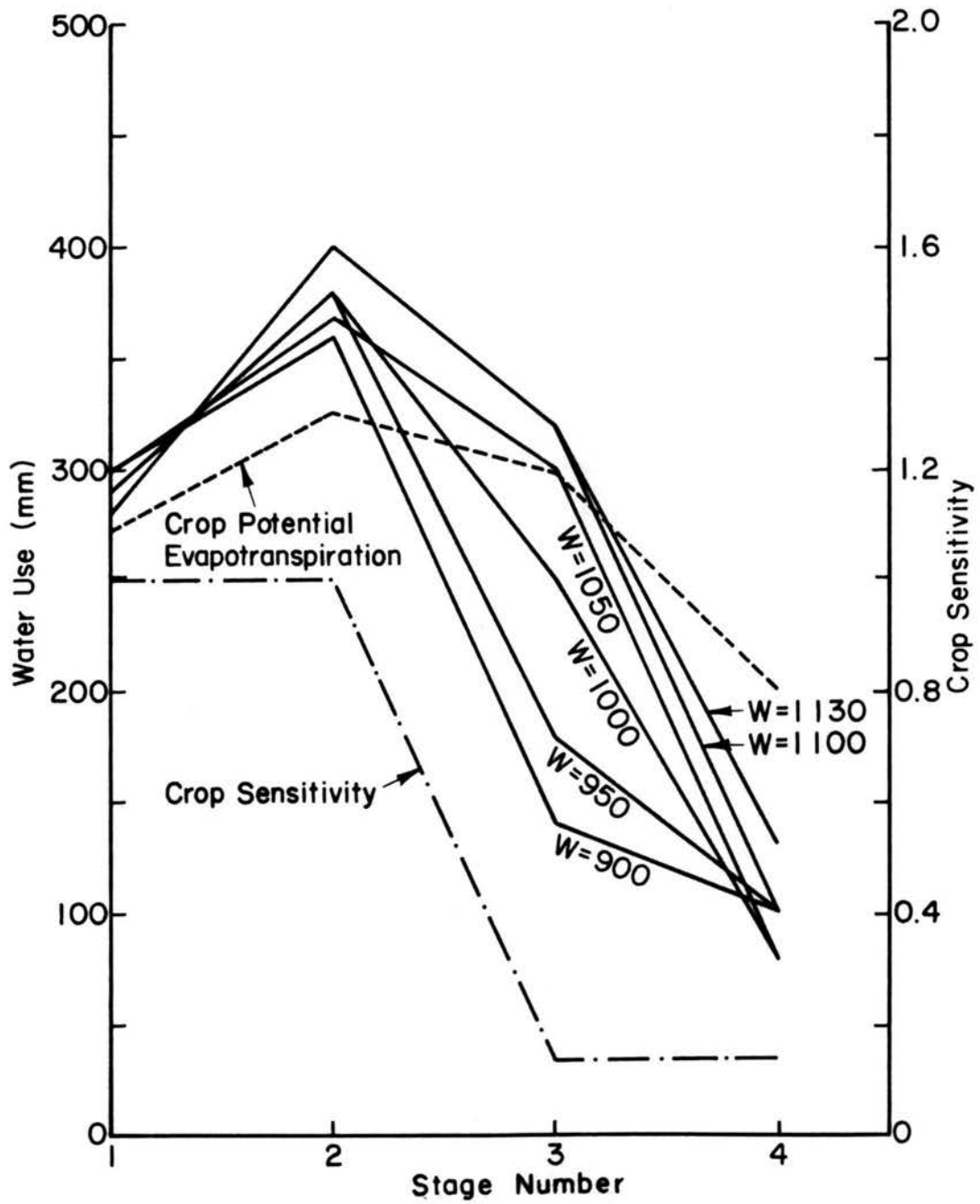

Figure 4.5.6 Optimal Irrigation Policies For Upland Rice

- (1) Farmers not using the excess water allocated to cotton and corn.
- (2) Farmers allocating the excess water to the other two crops proportional to the actual areas over and above the water allocation policy.

The results indicate that for the case under study, when we forecast a certain cropping pattern and take decisions about water allocation for different crops, and when the fractional areas do not change too widely from their mean values, the net benefits would not differ from their optimal values. Also, the results indicate that the simplistic approach of prioritizing water allocation on the basis of net benefits is tenable for the case under study. For the case of equal fractional areas which will be pursued subsequently, the stagewise decisions are given in Tables (4.5.5 a to 4.5.5 c) and Figure 4.5.7.

4.5.2 Optimal Irrigation Scheduling

As has already been mentioned, to achieve greater acreage, the design value of total water requirement might be slightly shifted from the potential water requirement. This falls in the preview of the water resources discipline. (See Dudley et.al. (1972)).

As an example, in the present case, the design value of the total water available is assumed to be 1120 mm ha. The optimal distributions are given in Figure 4.5.7. Scheduling suitable for the total distribution may be obtained by inspection. Table (4.5.6) gives the scheduling and also the unit depths required for each crop. The effect of rainfall and the groundwater contributions might be obtained from previously mentioned methods for the case of sufficient water supply.

TABLE 4.5.1

CROP DATA FOR OPTIMAL WATER ALLOCATION ANALYSIS

CROP	FRACTIONAL AREA OF CROP		MAXIMUM BENEFIT PER UNIT EXTENT (IN L.E.)	COST PER UNIT EXTENT (IN L.E.)	MAXIMUM USABLE WATER (AT YIELD = 100%) (mm ha)		MINMUM WATER REQUIRED (AT YIELD = 50%) (mm ha)	
	Case #	1			2	1	2	1
Cotton	0.33	0.30	267.0	173.0	500.0	450.0	260.0	240.0
Corn	0.33	0.25	156.0	78.0	320.0	240.0	100.0	80.0
Rice	0.33	0.45	140.0	103.0	360.0	500.0	140.0	180.0

TABLE 4.5.2

OPTIMAL ALLOCATION OF WATER FOR MULTIPLE CROPPED AREASCase I - Equal Fractional Areas

TOTAL WATER AVAILABLE FOR DISTRIBUTION (mm)	WATER ALLOCATED (mm ha)		
	COTTON	CORN	RICE
800.0	500.0	160.0	140.0
840.0	500.0	200.0	140.0
880.0	500.0	240.0	140.0
920.0	500.0	280.0	140.0
960.0	500.00	320.0	140.0
1000.0	500.0	320.0	180.0

TABLE 4.5.3

OPTIMAL ALLOCATION OF WATER FOR MULTIPLE CROPPED AREAS

Case 2 - Unequal Fractional Areas

TOTAL WATER AVAILABLE FOR DISTRIBUTION (mm)	WATER ALLOCATED (mm ha)		
	COTTON	CORN	RICE
800.0	440.0	180.0	180.0
840.0	440.0	220.0	180.0
880.0	440.0	240.0	200.0
920.0	440.0	240.0	240.0
960.0	440.0	240.0	280.0
1000.0	440.0	240.0	320.0

TABLE 4.5.4

SENSITIVITY ANALYSIS OF OPTIMAL ALLOCATION W.R.T. AREAS

TOTAL WATER AVAILABLE FOR DISTRIBUTION (mm ha)	WATER ALLOCATION UNDER THE ASSUMPTION OF CASE I (mm ha)			NET BENEFITS BY ADOPTING POLICY FOR CASE I (L.E.)		NET BENEFITS REALIZABLE (L.E.)	ERROR (PERCENTAGE)	
	COTTON	CORN	RICE	<u>SITUATION 1</u> (NON-USAGE OF EXTRA WATER TO COTTON)	<u>SITUATION 2</u> (OF USAGE OF EXTRA WATER)*		<u>SITUATION 1</u>	<u>SITUATION 2</u>
800.0	500.0	160.0	140.0	18.66	23.26	23.26	19.78	0.0
840.0	500.0	200.0	140.0	23.56	27.98	27.98	15.80	0.0
880.0	500.0	240.0	140.0	28.15	32.52	32.52	13.44	0.0
920.0	500.0	280.0	140.0	32.50	36.89	36.89	11.90	0.0
960.0	500.0	320.0	140.0	36.64	41.02	41.02	10.68	0.0
1000.0	500.0	320.0	180.0	41.48	44.97	44.97	7.76	0.0

* ALLOCATED WATER DISCRETIZED IN STEPS OF 20 MM AS IN THE USE OF DYNAMIC PROGRAMMING CODE.

TABLE 4.5.5 (a)
FINAL STAGewise DECISIONS FOR CORN

TOTAL AVAILABLE WATER (mm. ha)	WATER ALLOCATED TO THE CROP (mm. ha)	STAGewise ALLOCATIONS (mm. ha)			
		1	2	3	4
800.0	160.0	14.0	41.0	75.0	30.0
840.0	200.0	18.0	51.0	94.0	37.0
880.0	240.0	20.0	64.0	113.0	43.0
920.0	280.0	20.0	78.0	142.0	40.0
960.0 - 1160.0	320.0	20.0	108.0	158.0	34.0

TABLE 4.5.5 (b)

FINAL STAGewise DECISIONS FOR COTTON

TOTAL AVAILABLE WATER (mm.ha)	WATER ALLOCATED TO THE CROP (mm.ha)	STAGewise ALLOCATIONS (mm.ha)			
		1	2	3	4
800.0 - 1160.0	500.0	34.0	129.0	234.0	103.0

TABLE 4.5.5 (c)

FINAL STAGewise DECISIONS FOR RICE

TOTAL AVAILABLE WATER (mm. ha)	WATER ALLOCATED TO THE CROP (mm. ha)	STAGewise ALLOCATIONS (mm. ha)			
		1	2	3	4
800.0 -960.0	140.0	47.0	56.0	22.0	15.0
1000.0	180.0	60.0	72.0	28.0	20.0
1040.0	220.0	73.0	88.0	34.0	25.0
1080.0	260.0	87.0	104.0	40.0	29.0
1120.0	300.0	100.0	120.0	47.0	33.0
1160.0	340.0	98.0	125.0	90.0	27.0

TABLE 4.5.6

OPTIMAL IRRIGATION SCHEDULING

IRRIGATION DAY (JULIAN DAY)	REQUIREMENT DEPTH (MM)		
	COTTON	CORN	RICE
90	34.0	-	-
100	34.0	-	-
110	34.0	-	-
120	116.0	-	-
135	77.4	30.0	-
145	54.2	21.0	78.4
152	62.0	55.3	98.0
160	77.4	92.6	98.0
170	117.0	92.6	119.6
180	117.0	92.6	125.0
190	117.0	118.5	125.0
200	117.0	118.5	97.0
210	117.0	118.5	90.0
220	117.0	118.5	90.0
230	56.0	34.0	90.0
240	56.0	34.0	39.6
250	56.0	34.0	27.0
260	56.0	-	32.4
270	56.0	-	-
280	29.0	-	-

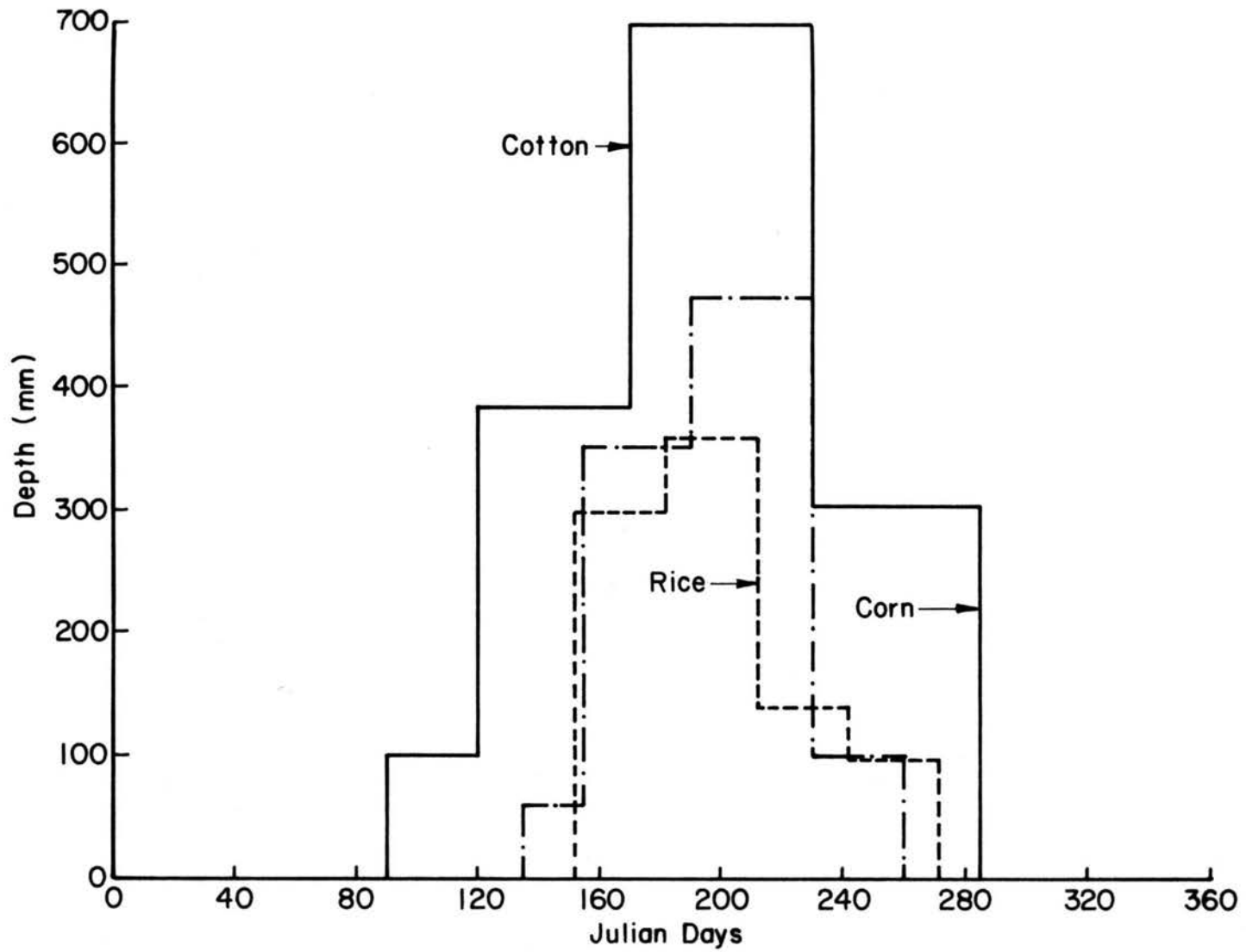

Figure 4.5.7 Optimal Depth Requirements for $W = 1120$ mm

4.6 CONCLUSIONS AND RECOMMENDATIONS

The turnout area water requirement problem involves two steps viz. computing the unstressed (gross) water requirement and computing the scheduling in an optimal manner. Climatic inputs, agronomic and economic data related to the crops grown in the area, sociological inputs regarding the farmer readiness and inputs regarding the available water resources, are all needed for the computation of turnout area (or farm) water (depth) requirements. The cultural practices may be suggested or be given according to the existing practices.

The unstressed requirements (design evapotranspiration values) are computed beginning from the day at which a certain prescribed fraction of farmers are ready for receiving the water. The cloud cover uncertainty is accounted for and the corresponding evapotranspiration values are computed at a given prescribed probability level of non-exceedance. From the monthly average values, shorter interval design evapotranspiration values are obtained using spline functions.

The scheduling problem for deficient or stress design is accomplished using the criterion of maximizing net benefits. This scheduling problem of allocating water to different crops over the stages was demonstrated to be solvable by a two step dynamic programming (which is being called double dynamic programming). At this stage the influence of different soil characteristics in stressing the evapotranspiration is neglected and Boonyatharakol's linear model was used.

The irrigation interval is fixed as an input at this stage, but the influence of this on canal sizes will be seen subsequently. The interval conforms to sustainable water in the root zone. The irrigation interval as would be seen subsequently has to be as long as possible to result in minimal canal sizes.

The above procedure is set in a deterministic mode as far as the water availability is concerned. The stochasticity of the available water may be dealt with using stochastic dynamic programming for the multi crop case, expanding the Hiler and Howell (1974) methodology for a single crop case. On the other hand, a pure Monte-Carlo simulation approach with variable water amounts may be attempted. These are recommended for future research.

It will be seen subsequently that as the requirement depths increase, the irrigation requirement efficiency decreases. If the irrigation interval is longer, then the requirement depth increases and reduces the irrigation requirement efficiency. It is believed that there is an optimal point between reduced canal systems costs and the cost of wasted water. This is recommended for further research.

CHAPTER 5

PROJECT SCALE FARM DESIGN MODULE

5.1 INTRODUCTION

In the turnout area water requirement module, a general methodology was developed for the evaluation of water requirement depths for given values of total available water for multiple crop areas. The general analysis of optimally allocating the seasonal water over the crop growth stages did not take into account the hydraulics of the system. In this module an analysis is made as to how the scheduled depths are related to the system variables such as the flow rate, the time of application and the field geometry. This analysis is done giving due consideration to the net benefit optimality of the system and to the constraints the farmer may have in operating the system. The project scale constraints and managerial decisions obtainable through the analysis are considered.

5.2 LITERATURE REVIEW

5.2.1 General

Surface irrigation application systems may be designed either at prescribed levels of requirement and application efficiency using the SCS approaches (Clyma, (1979)) or optimizing objectives such as cost, net benefits, etc. Recent research (See Chapter 4, References, Reddy, (1980), Reddy and Clyma (1980)) has emphasized the effect of the hydraulics of the surface irrigation application system as parameterized by the system design variables such as flow rate, time of application, length of the field, etc. on the

economic performance of the irrigation endeavor. These studies were directed towards on-farm situations and require extension for the case of project scale analyses where total water availability constraints require operating at higher application efficiency points. Reddy (1980) adopted a two stage process for the problem of optimal application system design. First, the hydraulic performance parameters of the system such as requirement efficiency and deep percolation ratio (Hart (1975)) are related to the systems parameters in functional form by the use of a hydraulic simulation model. Then the crop yield function is related to the requirement efficiency from which the net benefit function is obtained. For the extension of this approach, we require performance functions for the different kinds of applicaton systems that a surface irrigation project might have.

5.2.2 Hydraulic Performance Functions

Reddy (1981) has given performance functions of requirement efficiency and deep percolation for specific cases of graded and level borders using the zero-inertia model (Strelkoff and Katopodes (1977)).

El-Hakim (1984) gives the following relationships for graded border application systems:

Requirement Efficiency, E_r ,

$$E_r = \frac{0.834 I^{0.39}}{S^{0.18} D_u^{0.25}} \frac{T^{0.3375}}{q^{0.0525} L^{0.035}} \quad (5.2.1)$$

Application Efficiency, E_a ,

$$E_a = \frac{2.30 I^{0.29}}{S^{0.16}} D_u^{0.71} \frac{L^{0.84}}{q^{.92} T^{.63}} \quad (5.2.2)$$

Deep Percolation Ratio, R_p ,

$$R_p = \frac{0.0004}{S^{0.019}} I^{0.63} D_p^{.399} \frac{T_a^{.616}}{q^{.015} D_u} \quad (5.2.3)$$

$$R_r = 1 - R_p - E_a \quad (5.2.4)$$

In the above equations, the following are the notations:

- D_u = Requirement depth (ft);
- q = flow in (ft²/s);
- T = time of application (secs);
- L = length of the freely draining border (ft);
- S = slope of the border, and;
- I = SCS infiltration characteristic terminal intake rate (ins/hr).

From the relationship for E_r it may be seen that E_r decreases as D_u increases. This implies that one should irrigate as frequently as possible since D_u decreases, when the irrigation interval decreases. Since E_a decreases when D_u decreases, there is in fact an optimal point at which the system would have to be operated. In the formulation of the project scale farm design problem this optimal interval is given as an input.

For other surface irrigation application systems similar developments are possible. Reddy (1981) has given the requirement efficiency and deep percolation relationships for a specific case of level border. For furrows similar developments have not yet been attempted mainly due to the fact that a complete hydraulic model such as the zero-inertia model (Strelkoff and Katopodes (1977)) available for border irrigation systems is not yet available for furrows.

The development of requirement efficiency and deep percolation functions are quintessential for the farm design and such functions for level borders using the zero-inertia model (Moodie (1979)) and for furrows using the SCS advance formulae are given in the appendices.

5.2.3 Crop Production Functions Suitable For Project Scale Analysis

The multiplicative crop production functions that are in vogue are more suitable for on farm simulations rather than project scale analyses (Hiler and Howell, (1974), Dudley, et. al. (1971), Windsor and Ven Te Chow (1971), Hall and Butcher (1968) and Reddy (1982)). The reasons for such suitability lie in the extensive nature of simulation computations. Reddy (1980) adopted the approach of relating the crop yields to the requirement efficiencies for obtaining optimal on-farm decision variables. The extension of this approach for project scale analyses with proper modifications and with appropriate constraints will ease the computational efforts required to solve the project scale problem. Crop production functions, in the approach of Reddy (1980) may be given as:

$$y_r = a + b E_r + c E_r^2 \quad (5.2.5)$$

where y_r is the relative yield, E_r the requirement efficiency, and a , b and c are coefficients. For Reddy (1980) the requirement efficiency was constant at each irrigation of the season. If we require that the relative yield shall have a true maximum at $E_r = 1.0$ and should be 0 for $E_r = 0.0$ then, $b = 2(1-a)$ and $c = (1-a)$. For arid climates with no rainfall $a = 0$, and

$$y_r = 2.0 E_r - E_r^2 \quad (5.2.6)$$

An inspection of the above equation in comparison to the equation given by Reddy (1980) for wheat, shows that for $E_r \geq 60\%$ the error is less than 8%.

We will proceed to use the above equation for all crops and at each irrigation. When the above equation is used in each of the irrigations, the assumption becomes that the other irrigations are at 100% requirement efficiency.

5.3 PROJECT SCALE ANALYSIS OF OPTIMAL FARM DECISION VARIABLES

5.3.1 Variations Of Soil Characteristics In A Project Area

In a project area the soil characteristics and the slope of the fields are expected to vary from one part to another. The soil spatial variability in a watershed and its hydraulic properties has been studied by Peck, et. al. (1977) and Sharma and Luxmoore (1979). Extensive data collection is necessary for satisfactory accounting of such variabilities. Since the effect of slope and infiltration are dependent on the system characteristics, it is essential to group them appropriately according to the system at hand.

5.3.2 Efficiencies Of The Conveyance Systems

The analysis of optimal farm system variables, as related to the water availability at the source, needs estimates of conveyance efficiencies. Conveyance efficiencies depend on many factors such as the lengths of the conveyance systems, the types of the conveyance systems, the groundwater table positions, etc. Since these factors depend on crop water requirements, type of soils encountered, the boundary conditions for the water table movement, etc., the analysis could proceed only in an iterative manner. The first (or initial) analysis which might be sufficient in many cases is described here. Conveyance efficiency also might deteriorate with time because of weed growth, erosion and sedimentation, and improper care of the associated hydraulic structures. Due to the movement of groundwater and the variable amounts of water a conveyance system carries, conveyance efficiency is

expected to vary in general during an irrigation season. In the initial stages the seepage losses are expected to be high and the surface losses due to improper conveyance low. As the season progresses, the water table rises due to deep percolation and the seepage losses reduce, but the losses due to improper conveyance increase since the flow rates increase. Therefore, computing initial conveyance efficiencies assuming no surface conveyance loss for the first analysis is a viable approach.

5.3.3 Seepage Losses From Canals

Sritharan (1982) has reviewed the state of the art of canal seepage losses. The main problem with canal seepage studies is the essential two dimensional dispersion from the canal to the water table. Sritharan (1982a) proposed the integral equation of the form (See Chapter 6 for notations)

$$qD' - \lambda WK (D' + H) = (q - \lambda WK) \int_0^{\tau} \frac{1}{T} \sqrt{\frac{k}{\pi}} (t-\tau)^{1/2} \frac{\partial q}{\partial \tau} d\tau \quad (5.3.1)$$

for the solution of unsteady seepage from canals where λ is a factor that would account for the two dimensional dispersion that takes place in the region of hydraulic connection. Abdulrazzak (1982) proposed

$$h(\tau) = \frac{2q_0}{T} \sqrt{\frac{kt}{\pi}} - \frac{2q_0}{T(D'+H)} \int_0^{\tau} \sqrt{\frac{k}{\pi}} (t-\tau)^{1/2} \frac{\partial h}{\partial \tau} d\tau \quad (5.3.2)$$

where q_0 is the flow rate at the time of hydraulic connection. Since the evaluation of λ in the former of these two formulae needs study and since the latter was verified experimentally, the formula of Abdulrazzak (1982) is used in the seepage loss studies. The solution of the latter equation is given by (Abdulrazzak (1982))

$$q(t) = q_0 \exp\left(-\frac{q_0^2 kt}{(T(D+H))^2}\right) \operatorname{erfc}\left(\frac{q_0 \sqrt{kt}}{T(H+D)}\right) \quad (5.3.3)$$

Thus, the rate of seepage discharge will be known at any time if the canal flow parameters are known.

The conveyance efficiency of a canal of reach, L , at time t releasing a flow Q_0 is given by

$$E_c = \frac{Q_0}{(Q_0 + q(t)L)} \quad (5.3.4)$$

If the flow conditions varied at N discrete steps, the overall conveyance efficiency will be given by

$$E_c = \prod_{i=1}^N \frac{Q_{oi}}{(Q_{oi} + q_i(t)L_i)} \quad (5.3.5)$$

This formula is valid for branched systems as long as the functions of the branches are not included in any one discrete step.

5.3.4 Deep Percolation Limits

Deep percolation requires control for the reduction of possible hazardous water table build up and in cases of deep water tables, for reduction of loss of applied or naturally present nutrients. The theories (developed in Chapter 6) for water table build up have to be used in an iterative fashion to find the limits on deep percolation losses.

5.3.5 Effects Of The Application System Types On Project Performance

Since each one of the many available surface irrigation application system types vary from another in the aspects of water use and cost, the type or types of the application systems need to be included in the determination of turnout flow requirements that are optimal at the project scale. The choice of systems depend also on factors such as the cultural practices of the farmers.

The project system analysis requires discretization of the parameters of soil characteristics into a finite number of distinguishable soil parametric types. This discretization depends on the type of application systems since the water use efficiencies will show different variations with the soil parameters in different systems.

Graded Border Systems

For both E_r and E_a (Equation 5.2.1 and 5.2.2) the influence of I is a direct power and the influence of S is an inverse power. A way to divide the project area into distinguishable soil parameter types is to consider divisions of low I high S values gradually to high I low S values. Two aspects are of interest here. The slope S instead of being a parameter could be made a variable considering land leveling and I varies during the irrigation season (Gates (1980)). Since the influence of I is direct on both E_r and E_a it is preferable to design on the lowest value I would take during a season. The number of such divisions of distinguishable soil parametric types depends in general on the application system, the total variation of soil types and the computational resources.

For graded border systems using Equation 5.2.1, the total variation δE_r in requirement efficiency due to a shift δI in I and δS in S is given by

$$\left(\frac{\delta E_r}{E_r} \right) = .39 \left(\frac{\delta I}{I} \right) - .18 \left(\frac{\delta S}{S} \right) \quad (5.3.6)$$

Considering relative steps of 10% in E_r , the above equation may be used to obtain the steps of SI and SS to get distinguishable soil parametric types.

Furrow Systems

Sensitivity relationships similar to that for graded border are developed using the basic E_r relationship for furrows and are given in Appendix 5.1. The total shift δE_r in E_r using the first (approximate) regression is given by

$$\left(\frac{\delta E_r}{E_r}\right) = .142 \left(\frac{\delta I}{I}\right) - .13 \left(\frac{\delta S}{S}\right) \quad (5.3.7)$$

This might be further improved by the improved regression for E_r as

$$\frac{\delta E_r}{E_r} = \left(\frac{\sum_{i=1}^5 a_i x^i}{\sum_{i=0}^5 a_i x^i} \right) \left(.142 \left(\frac{\delta S}{I}\right) - .13 \left(\frac{\delta S}{S}\right) \right) \quad (5.3.8)$$

However the use of the Equations (5.3.8) requires the average values of the system parameters. Therefore, it is preferable to use the first expression for the identification of discrete steps of I and S in which the project area might be subdivided.

Level Border Systems

A regression analysis was performed to obtain functional relationship with system parameters for the required efficiency, E_r . A general regression resulted in the following equation:

$$E_r = \frac{7.727 I .0133 q .357 T .263}{D_u .516 L .228} \quad (5.3.9)$$

with an $r^2 = .734$.

This r^2 was deemed low and regression was performed for different soil groups I. The above equation gives for the sensitivity function ($\delta E_r/E_r$) the following equation:

$$\frac{\delta E_r}{E_r} = .0133 \left(\frac{\delta I}{I}\right) \quad (5.3.10)$$

This equation shows that the level border systems are relatively less sensitive (about E_r) to the variation in I when compared with graded border systems.

5.3.6 Formulation Of The Project Scale Decision Problem

The analysis of turnout flow requirements cannot be accomplished ignoring the variations in the soil characteristics within the project area.

When such variations are taken into account, the farm decision variables vary from one portion of the project to another. The objective of this section is to formulate the problem of obtaining maximum net benefits from a project area that is expected to be cultivated with a number of crops, under the constraints that exist in the project considering also the variation in the soil characteristics. This would help the manager of the project to decide how much water to be allocated where and for how long.

The general approach for formulating this problem would be to analyse each of the critical irrigations, when the total crop requirements are more, using the crop production functions of the form of Equation (5.2.5), for total net benefit evaluations from the project area. All relevant constraints both on the farm land and the project level will be included.

Notations (Please see Figure 5.3.1)

- A_j - The area of land with soil parameter type index j .
- N_p - Total number of soil parameter types.
- f_{ij} - The average function of area A_j that is expected to be planted with crop of index i in area A_j .
- N_c - Total number of crops
- E_{rij} - The requirement efficiency of irrigation crop i in area j .
- A_T - Total project irrigable area.
- E_{cj} - The conveyance efficiency of the system from the source to area j . (If soil parameter type j happened to be in two or more distinct places repeat indexing to accommodate different E_{cj} .)

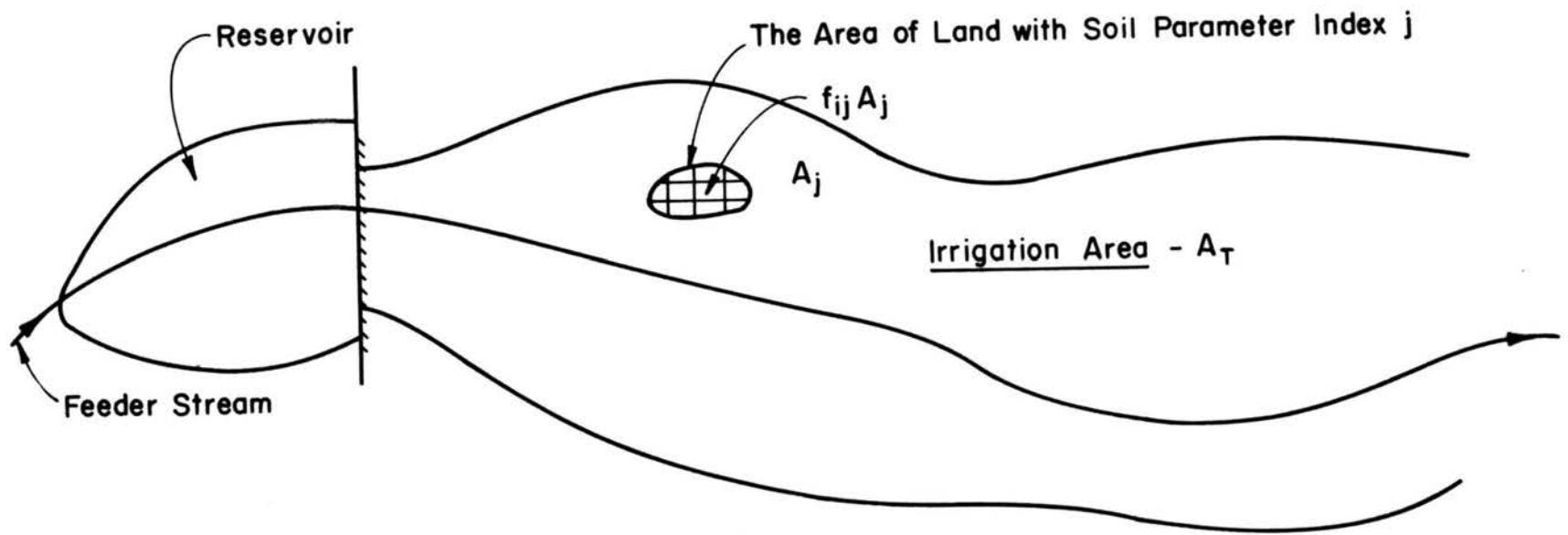

Figure 5.3.1 A Typical Reservoir Irrigation Project

The total net benefit from the project area is given by

$$Y = \sum_{j=1}^{N_p} \sum_{i=1}^{N_c} \left\{ ((2E_{rij} - E_{rij}^2)) y_{mi} b_i - c_i A_j f_{ij} \right\} \quad (5.3.11)$$

we have

$$\sum_{i=1}^{N_c} f_{ij} = 1.0 \quad (5.3.12)$$

and

$$\sum_{j=1}^{N_p} A_j = A_T \quad (5.3.13)$$

Thus the objective function is

$$\left\{ \underset{X}{\text{MAX}} \quad Y = \sum_{j=1}^{N_p} \sum_{i=1}^{N_c} \left\{ ((2E_{rij} - E_{rij}^2)) y_{mi} b_i - c_i A_j f_{ij} \right\} \right\}$$

where

$$\underline{X} = \left\{ \begin{array}{c} \underline{q} \\ \underline{L} \\ \underline{T} \end{array} \right\} \quad (5.3.14)$$

Constraints

Constraints related to realising maximum net benefits from the project area may be divided into on-farm constraints and total (project) water availability constraints.

On-Farm Constraints

Flow constraints:

$$q_{ij} \geq q_{lj} \quad 1 \leq j \leq N_p \quad (5.3.15)$$

where q_{lj} is the minimum flow required for sufficient spreading of the water.

$$q_{ij} \leq q_{uj} \quad 1 \leq j \leq N_p \quad (5.3.16)$$

where q_{uj} is the maximum flow permissible considering the erosion aspect of the depth of flow considerations.

Application Time Constraints

In many instances farmers have labor availability constraints for irrigation which might require that the farmer be issued water for a duration greater than a given value. Even though this minimum time might be the same throughout the project, allowing for variability we might write,

$$T_{ij} \geq T_{lj} \quad (5.3.17)$$

There is also an upperbound on the time of application limited by sun light hours, etc., and therefore

$$T_{ij} \leq T_{uj} \quad (5.3.18)$$

Farm Length Constraints

Farm lengths have an upper bound due to the farm configuration and this may be given as

$$L_{ij} \leq L_{uij} \quad (5.3.19)$$

Farm length will also have a lower bound considering the share required for the movement of farm machinery etc. and this may be expressed by

$$L_{ij} \leq L_{lij} \quad (5.3.20)$$

Deep Percolation Constraints

In general the deep percolation losses are likely to increase at higher requirement efficiencies. In many areas deep percolation losses have to be controlled to reduce long term water table build up problems. This may be expressed by

$$\frac{q_{ij} T_{ij}}{L_{ij}} R_{pij} \leq D_{pj} \quad (5.3.21)$$

where R_{pij} is the deep percolation ratio and D_{pj} the permissible deep percolation in area j . The permissible D_{pj} may be obtained using the analysis of water table build up.

Total Water Availability Constraint

Total water available for the project area is limited by the water available from the source. Since the analysis here is on the basis of irrigation by irrigation, the water availability at the source only during the irrigation studied would be included. The approach would also facilitate the reservoir study with seasonal inputs. This constraint may be expressed as

$$\sum_{j=1}^{N_p} \sum_{i=1}^{N_c} \frac{q_{ij} T_{ij}}{L_{ij} E_{cj}} f_{ij} A_j \leq V_s \quad (5.3.22)$$

where V_s is the water availability from the source for the particular irrigation concerned.

Solution Approach

It is readily seen that this problem may be solved by dynamic programming (Nemhauser (1966)). The E_r and D_p relationships depend on the requirement depth D_u for any crop and the general limits on q , L and T are independent of the crops.

Since the analysis centers around peak requirement periods in which the different requirements are approximately equal (Table 4.5.7) the dimensionality of the problem is reduced by setting

$$\left. \begin{aligned} E_{rij} &= E_{rj} \\ q_{ij} &= q_j \\ L_{ij} &= L_j \\ T_{ij} &= T_j \end{aligned} \right\} \text{ and} \quad (5.3.23)$$

In this case the objective function is

$$\text{MAX}_{\underline{X}} \left\{ Y = \sum_{j=1}^{N_p} \left\{ 2E_{rj} - E_{rj}^2 \right\} B - C A_j \right\} \quad (5.3.24)$$

where

$$\underline{X} = \left\{ \begin{array}{c} \underline{q} \\ \underline{L} \\ \underline{T} \end{array} \right\} \quad (5.3.25)$$

and

$$B = \frac{1}{N_c} \sum_{i=1}^{N_c} y_{mi} b_i \quad (5.3.26)$$

and

$$C = \frac{1}{N_c} \sum_{i=1}^{N_c} c_i \quad (5.3.27)$$

Solution is obtained by developing sub-optimal decisions, \underline{X} , and corresponding yields, Y_{sj} , for each area, A_j , for different given values of the water available, W_j , at area, j . Then these functions are used for the project scale decision of the optimal apportionment W_j^* of the water available at the

source to the different areas with different soil characteristics, using the previous sub-optimal analysis, of the decision variables corresponding to W_j^* are obtained.

The solution, thus obtained, is the solution that would result in maximum net benefits from the project area. However, this results in the non-equitable distribution of unit area water. If equity has to be weighed, the final decision variable, W_f^* , might be obtained by setting

$$W_f^* = W_1 W_1^* + W_2 W_e^* \quad (5.3.28)$$

where W_e is the distribution of the water amounts under the requirement of equity.

5.4 APPLICATION OF THE APPROACH

5.4.1 Project Details

The above approach is applied to a hypothetical project of extent 20,000 acres growing cotton, corn, and rice. The details of the soil parameter types, irrigation application systems and first trial canal capacities are given in Tables 5.4.1, 5.4.2, 5.4.3, and 5.4.4. The details of system layout are given in Figures 5.4.1 and 5.4.2.

The application systems are level basins which are not very long. The average farm size is taken as 5 acres and it is assumed that farmers can handle 4 basins at a time. In fact, from a general study, as the number of basins that are simultaneously irrigable by the farmer increases, the yield increases for any given amount of applied water.

5.4.2 Sub-Optimal Analysis

The sub-optimal analysis is done using the fact that the yield function is monotonic - increasing in E_r for $0.0 \leq E_r \leq 1.0$. Thus the transformed problem for sub-optimal analysis is:

TABLE 5.4.1
PROJECT DETAILS

SUBJECT	DETAIL
Total Irrigatable Area	20,000 Acres
Crops Grown	Cotton, Rice & Corn
Average Expected Proportion Of Each Of The Crop Area	.333, .333, .333
Infiltration Parameter Variation (SCS Family Number)	.1, .5, 1.0, and 1.5
Application System Type	Level Borders
Average Farm Size	5 acres

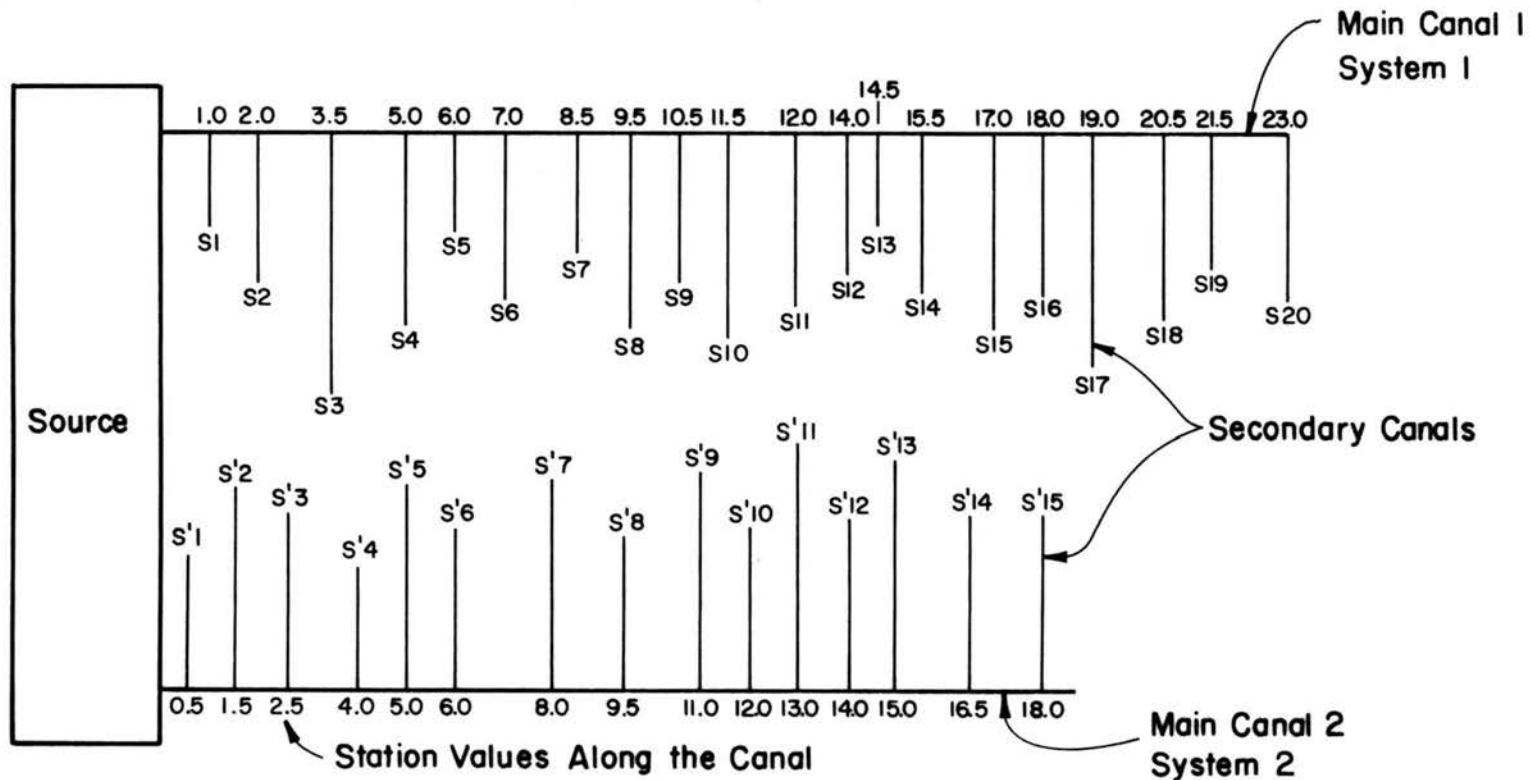

Figure 5.4.1 Idealized View Of The Project System

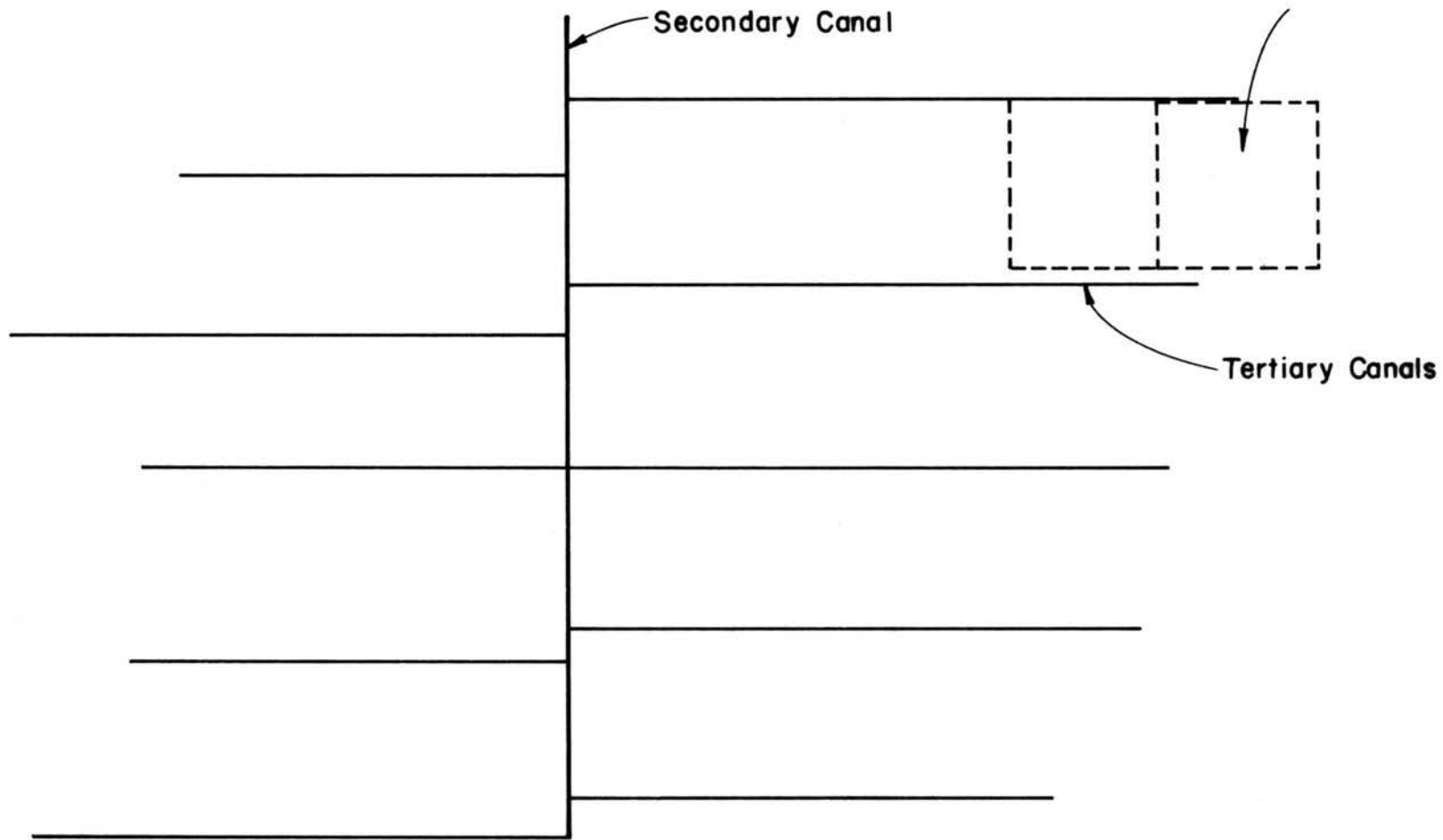

Figure 5.4.2 Idealized View Of Secondary And Tertiary Conveyance Systems

Table 5.4.2 - SYSTEM I DETAILS

Secondary Canal Number	Area Served (Acres)	Soil Parameter Group	Length To The First Moment of Area (ft)	First Trial Canal Capacities (cfs)		First Trial Design Width (ft)	
				Main Canal	Secondary Canal	Main Canal	Secondary Canal
S1	600	2	4700.0	382.0	25.0	20.0	6.0
S2	620	2	6100.0	363.0	26.0	18.0	6.0
S3	800	2	10080.0	344.0	33.0	18.0	6.0
S4	740	1	4800.0	296.0	18.0	17.0	4.0
S5	440	1	4800.0	296.0	18.0	17.0	4.0
S6	620	1	6400.0	282.0	26.0	15.0	6.0
S7	450	1	5770.0	263.0	19.0	14.0	4.0
S8	730	1	7200.0	249.0	30.0	14.0	6.0
S9	580	1	6100.0	226.0	24.0	14.0	6.0
S10	740	1	7400.0	208.0	31.0	13.0	6.0
S11	590	3	6600.0	185.0	24.0	13.0	6.0
S12	410	3	5900.0	167.0	17.0	11.0	4.0
S13	440	3	4700.0	154.0	18.0	11.0	4.0
S14	610	3	6520.0	141.0	28.0	11.0	6.0
S15	640	3	7900.0	120.0	26.0	10.0	6.0
S16	600	3	6600.0	100.0	25.0	10.0	6.0
S17	770	4	9200.0	81.0	32.0	8.0	6.0
S18	620	4	6600.0	57.0	26.0	8.0	6.0
S19	400	4	5900.0	38.0	17.0	8.0	4.0
S20	600	4	6480.0	25.0	25.0	6.0	6.0

Table 5.4.2 - SYSTEM 1 DETAILS (Continued)

Secondary Canal Number	First Trial Design Flow Depth (ft)		Depth To Initial Water Table (ft)	K (ft/day)	Maximum Seepage (ft ² /day)		Conveyance Efficiency From Source
	Main Canal	Secondary Canal			Main Canal	Secondary Canal	
S1	5.50	1.50	50.0	.6	13.32	3.71	.99
S2	5.50	1.50	50.0	.6	11.99	3.71	.98
S3	5.50	1.75	52.0	.6	11.94	3.72	.98
S4	5.50	1.75	52.0	.6	11.94	3.72	.98
S5	5.00	1.50	54.0	.5	9.29	2.06	.98
S6	5.00	1.50	54.0	.5	8.19	3.08	.97
S7	5.00	1.50	60.0	.5	7.58	2.05	.97
S8	5.00	1.75	60.0	.5	7.51	3.09	.97
S9	4.50	1.50	62.0	.5	7.51	3.07	.97
S10	4.50	1.75	62.0	.5	6.68	3.08	.96
S11	4.00	1.50	62.0	.8	11.07	4.92	.96
S12	4.00	1.50	56.0	.8	9.43	3.29	.96
S13	4.00	1.50	54.0	.8	9.45	3.29	.95
S14	4.00	1.75	50.0	.8	9.50	4.97	.95
S15	4.00	1.50	46.0	.8	8.70	4.96	.95
S16	4.00	1.50	42.0	.8	8.76	4.97	.94
S17	3.00	1.75	38.0	1.0	8.63	6.28	.93
S18	2.50	1.50	36.0	1.0	8.56	6.25	.92
S19	2.50	1.50	34.0	1.0	8.59	4.18	.91
S20	2.50	1.50	30.0	1.0	6.50	4.13	.89

Table 5.4.3 - SYSTEM 2 DETAILS

Secondary Canal Number	Area Served (Acres)	Soil Parameter Group	Length To The First Moment of Area (ft)	First Trial Canal Capacities (cfs)		First Trial Design Width (ft)		First Trial Design Depth of Flow (ft)	
				Main Canal	Secondary Canal	Main Canal	Secondary Canal	Main Canal	Secondary Canal
S1'	500.00	2	5600.0	254.0	21.0	14.0	5.0	5.0	1.50
S2'	620.0	2	6400.0	239.0	26.0	14.0	6.0	4.5	1.50
S3'	580.0	2	5780.0	219.0	24.0	14.0	6.0	4.5	1.50
S4'	480.0	1	5200.0	201.0	20.0	13.0	5.0	4.5	1.50
S5'	630.0	1	7200.0	186.0	26.0	13.0	6.0	4.0	1.50
S6'	520.0	1	5900.0	167.0	22.0	11.0	5.0	4.0	1.50
S7'	610.0	1	6300.0	150.0	25.0	11.0	6.0	4.0	1.50
S8'	460.0	1	4960.0	131.0	19.0	11.0	5.0	4.0	1.50
S9'	620.0	1	6800.0	117.0	16.0	10.0	6.0	4.0	1.50
S10'	480.0	1	5100.0	98.0	10.0	10.0	5.0	4.0	1.50
S11'	640.0	1	8220.0	83.0	27.0	9.0	6.0	3.0	1.50
S12'	470.0	2	5860.0	62.0	20.0	8.0	5.0	3.0	1.50
S13'	620.0	2	9100.0	47.0	26.0	8.0	6.0	2.5	1.50
S14'	420.0	2	6800.0	28.0	17.0	6.0	4.0	2.5	1.50
S15'	360.0	2	4880.0	15.0	15.0	4.0	4.0	2.0	1.50

Table 5.4.3 - SYSTEM 2 DETAILS (Continued)

Secondary Canal Number	Initial Depth of Water Table	K (ft/day)	Maximum Seepage (ft ² /day)		Conveyance Efficiency	
			Main Canal	Secondary Canal	Main Canal	Overall
S1'	48.0	.6	9.28	3.09	.99	.99
S2'	48.0	.6	9.19	3.71	.99	.99
S3'	48.0	.6	9.19	3.71	.99	.99
S4'	48.0	.5	7.11	2.58	.99	.98
S5'	44.0	.5	7.09	3.10	.99	.97
S6'	44.0	.5	6.00	2.59	.99	.97
S7'	44.0	.5	6.00	3.10	.99	.97
S8'	44.0	.5	6.00	2.59	.99	.96
S9'	44.0	.5	5.45	3.10	.99	.96
S10'	42.0	.5	5.48	2.59	.99	.95
S11'	42.0	.5	4.82	3.11	.99	.95
S12'	42.0	.6	5.14	2.59	.99	.95
S13'	40.0	.6	5.10	3.74	.98	.93
S14'	40.0	.6	3.83	2.49	.99	.93
S15'	40.0	.6	2.49	2.49	.98	.91

TABLE 5.4.4 SOIL GROUP PARAMETERS

Soil Group Number	Average Infiltration Characteristic SCS Family Number	Area (Acres)	Average Conveyance Efficiency
1	0.10	8000.0	0.97
2	0.50	6320.0	0.97
3	1.0	3290.0	0.95
4	1.50	2390.0	0.91

$$\text{Max}_{q,T,L} E_r = \frac{c q^{\alpha_1} T^{\alpha_2}}{\beta D_u L^{\alpha_3}} \quad (5.4.1)$$

subject to:

$$q_{\min} \leq q \leq q_{\max} \quad (5.4.2)$$

$$L_{\min} \leq L \leq L_{\max} \quad (5.4.3)$$

$$n = (A_f/WL) 1/n_t \quad (5.4.4)$$

$$nT \leq T_{\max} \quad (5.4.5)$$

$$T \geq T_{\min} \quad (5.4.6)$$

where A_f is the area farmer chooses to irrigate in any single irrigation, n_t is the number of borders simultaneously irrigable by the farmer and n is the number of border sets (with each set having n_t basins) in area A_f .

This problem is transformed to a linear-programming problem by setting all the units to read to values greater than 1.0 and by taking logarithms of the objective function and the constraints.

Now the log-transformed problem is:

$$\text{Max } y = a_0 + \alpha_1 x_1 + \alpha_2 x_2 - \alpha_3 x_3 \quad (5.4.7)$$

where

$$\left. \begin{aligned} x_1 &= \log q \\ x_2 &= \log T \\ x_3 &= \log L \end{aligned} \right\} \quad (5.4.8)$$

$$a_0 = \log (c/D_U^\beta) \quad (5.4.9)$$

S.t.

$$b_{11} \leq x_1 \leq b_{12} \quad (5.4.10)$$

$$x_2 \geq b_{22} \quad (5.4.11)$$

$$x_2 = x_3 \leq b_0 \quad (5.4.12)$$

$$b_{31} \leq x_3 \leq b_{32} \quad (5.4.13)$$

where

$$b_{11} = \log q_{\min}, \quad b_{12} = \log q_{\max}$$

$$b_{22} = \log T_{\max} \quad b_{22} = \log (T_{\max} Wn_L/A_f) \quad (5.4.14)$$

$$b_{31} = \log L_{\min} \quad \text{and} \quad b_{32} = \log L_{\max}$$

The constraints in each area are given in Table 5.4.5. The results of the sub-optimal analysis are given in Tables 5.4.6 to 5.4.9.

5.4.3 Project Scale Optimality

The optimal distribution of a given amount of water in the reservoir over the areas can be obtained now by using the sub-optimal analyses for the different areas and using the dynamic programming approach (Nemhauser (1966)). The results of this study are given in Table 5.4.8. It is seen that the order of priority for the allocation of water depends on many factors and could be discerned only by an optimization procedure.

5.4.4 Optimal Solution vs Equitable Distribution

The distribution of water, W_{ej} , under requirements of equity at the delivered areas is given by

$$W_{ej} = \frac{V_{Res} A_j}{N_p \sum_{j=1}^p (A_j/E_{cj})} \quad (5.4.15)$$

These values are given in Table 5.4.11.

The final solution for the distribution is obtained by assigning weights W_1 and W_2 for the optimal and equitable solutions. Assuming the water available is 9500 acft at the reservoir and setting $W_1 = 0.6$ and $W_2 = 0.4$ the optimal decision variables are given in Table 5.4.12.

5.4.5 Operational Parameters Over The Season

The design of farm application system based on the peak requirement defines the length parameter. The flow and the time of application need be determined for other irrigations. The previous process of optimizing at the peak requirement may be repeated for each and every irrigation. The results of this analysis and the operational parameters are given in Tables 5.4.13 to 5.4.16.

In this process we worked with the average requirement depth for those crops. Only in a few cases of irrigation, the individual crop requirements varied widely from the average requirement depth. The flow rates given in Tables 5.4.11 to 5.4.14 determine the total flow delivered to each farm. One way in which farmers can increase or decrease the amount of flow is by altering the number of sets of borders (furrows) he irrigates simultaneously according to the actual requirement depth of each crop in relation to the average requirement depth. The time of application also may be adjusted to obtain greater applied depths for those crops needing more water.

TABLE 5.4.5
CONSTRAINTS ON-FARM SYSTEMS PARAMETERS

Soil Group #	Bounds on Flow Rate (cfs/ft)*		Bounds on Field Length (ft)		Bound on Time of Application (hrs)	
	Lower Bound	Upper Bound	Lower Bound	Upper Bound	Lower Bound	Upper Bound
1	0.0	.15	50.0	90.0	3.0	12.0
2	0.0	.15	50.0	110.0	3.0	12.0
3	0.0	.20	50.0	130.0	3.0	12.0
4	0.0	.20	40.0	130.0	3.0	12.0

*Limited by depth of flow for level border

TABLE 5.4.6
SUB-OPTIMAL ANALYSIS FOR AREA 1

Available Water Per Unit Area (ft)	Flow Rate (cfs/ft)	Length (ft)	Time of Application (Minutes)	Requirement Efficiency	Returns (L.E.) ($\times 10^6$)
.3	.0063	90.0	71.4	.621	.344
.35	.00735	90.0	71.4	.713	.436
.40	.00840	90.0	71.4	.804	.502
.45	.00945	90.0	71.4	.894	.543
.50	.0105	90.0	71.4	.982	.560
.55	.01155	90.0	71.4	1.0	.560

I = 0.1
 Area = 8000 Acres
 Requirement Depth = 0.39 (ft)
 $A_f = 5$ acres

TABLE 5.4.7
SUB-OPTIMAL ANALYSIS FOR AREA 2

Available Water Per Unit Area (ft)	Flow Rate (cfs/ft)	Length (ft)	Time of Application (Minutes)	Requirement Efficiency	Returns (L.E.) ($\times 10^6$)
.30	.00630	110.0	87.3	.680	.321
.35	.00735	110.0	87.3	.774	.384
.40	.00840	110.0	87.3	.865	.421
.45	.00945	110.0	87.3	.953	.440
.50	.01050	110.0	87.3	1.0	.442
.55	.01155	110.0	87.3	1.0	.442

I = 0.5
 Area = 6320 Acres
 Requirement Depth = 0.39 (ft)
 $A_f = 5$ acres

TABLE 5.4.8
SUB-OPTIMAL ANALYSIS FOR AREA 3

Available Water Per Unit Area (ft)	Flow Rate (cfs/ft)	Length (ft)	Time of Application (Minutes)	Requirement Efficiency	Returns (L.E.) ($\times 10^6$)
.30	.0063	130.0	103.1	.728	.184
.35	.00735	130.0	103.1	.782	.201
.40	.00840	130.0	103.1	.832	.213
.45	.00945	130.0	103.1	.880	.221
.50	.0105	130.0	103.1	.924	.227
.55	.01155	130.0	103.1	.966	.230
.60	.01260	130.0	103.1	1.00	.230

I = 1.0
 Area == 3290.0 Acres
 Requirement Depth = 0.39 (ft)
 $A_f = 5$ Acres

TABLE 5.4.9
SUB-OPTIMAL ANALYSIS FOR AREA 4

Available Water Per Unit Area (ft)	Flow Rate (cfs/ft)	Length (ft)	Time of Application (Minutes)	Requirement Efficiency	Returns (L.E.) ($\times 10^6$)
.30	.0063	130.0	103.1	.769	.143
.35	.00735	130.0	103.1	.877	.160
.40	.00840	130.0	103.1	.903	.163
.45	.00945	130.0	103.1	.927	.165
.50	.0105	130.0	103.1	.949	.166
.55	.01155	130.0	103.1	.969	.167
.60	.01260	130.0	103.1	1.000	.167

I = 1.5
 Area = 2390.0 Acres
 Requirement Depth = 0.39
 $A_f = 5$ acres

TABLE 5.4.10
PROJECT SCALE OPTIMAL DISTRIBUTION
OF WATER AT PEAK REQUIREMENT

Water Apportioned From The Reservoir (Ac.Ft.)	Distribution (Ac.Ft.)			
	Area 1	Area 2	Area 3	Area 4
7000.0	4100.0 (3936.0)	1900.0 (1824.0)	500.0 (470.0)	500.0 (450.0)
7500.0	4100.0 (3936.0)	2400.0 (2304.0)	500.0 (470.0)	500.0 (450.0)
8000.0	4100.0 (3936.0)	2700.0 (2592.0)	600.0 (564.0)	600.0 (540.0)
8500.0	4100.0 (3936.0)	3100.0 (2976.0)	600.0 (564.0)	700.0 (630.0)
9000.0	4100.0 (3936.0)	3200.0 (3072.0)	800.0 (752.0)	900.0 (810.0)
9500.0	4100.0 (3936.0)	3200.0 (3072.0)	1200.0 (1128.0)	1000.0 (900.0)

* (Figures within parentheses refer to the water required at the receiving points.)

TABLE 5.4.11
DISTRIBUTION OF WATER AT PEAK REQUIREMENT
UNDER CONDITIONS OF EQUITY

Water Apportioned From The Reservoir (Ac.Ft.)	Distribution (Ac.Ft.)			
	Area 1	Area 2	Area 3	Area 4
7000.0	2657.0	2099.0	1093.0	794.0
7500.0	2847.0	2249.0	1171.0	851.0
8000.0	3037.0	2399.0	1249.0	907.0
8500.0	3227.0	2549.0	1327.0	964.0
9000.0	3417.0	2699.0	1405.0	1021.0
9500.0	3607.0	2849.0	1483.0	1077.0

TABLE 5.4.12
VALUES OF DESIGN VARIABLES
AT THE PEAK REQUIREMENT

Design Variables	Area 1	Area 2	Area 3	Area 4
q (cfs/ft)	.00999	.00991	.00820	.00854
L (ft)	90.0	110.0	130.0	130.0
T (mts)	71.0	87.0	103.0	103.0
Applied Depth (ft)	0.47	0.47	0.39	0.41
E_r	.95	.97	.82	.91
E_a	.77	.81	.82	.87

Table 5.4.13 - VALUES OF APPLICATION SYSTEM VARIABLES - AREA 1

Irrigation Number	Average Requirement Depth (ft)	Total Reservoir Water (Ac/Ft)	Water For The Area Under Equity (Ft)	Final Decision Values			
				q (cfs/ft)	T (minutes)	E _r	D _p
1	.11	800	.114	.00200	36.0	.96	.008
2	.11	800	.114	.00200	86.0	.96	.008
3	.11	800	.114	.00200	86.0	.96	.008
4	.38	3100	.441	.00309	214.0	.97	.072
5	.18	2600	.185	.0026	107.0	.91	.021
6	.17	3500	.166	.00393	71.0	.94	.006
7	.24	5000	.237	.00549	71.0	.90	.021
8	.29	6800	.323	.00731	71.0	.95	.048
9	.36	8800	.418	.00923	71.0	.94	.080
10	.37	9000	.427	.00946	71.0	.94	.079
11	.39	9500	.451	.00999	71.0	.93	.088
12	.36	8800	.418	.00923	71.0	.94	.080
13	.36	8800	.418	.00923	71.0	.94	.080
14	.36	8800	.418	.00923	71.0	.94	.080
15	.20	4200	.199	.00454	71.0	.91	.017
16	.14	2700	.128	.00298	71.0	.90	.002
17	.13	2500	.119	.00275	71.0	.90	.002
18	.15	2200	.157	.0022	107.0	.94	.016
19	.18	1300	.185	.0020	139.0	.93	.018
20	.10	700	.100	.0020	75.0	.93	.007

Table 5.4.14 - VALUES OF APPLICATION SYSTEM VARIABLES - AREA 2

Irrigation Number	Average Requirement Depth (ft)	Total Reservoir Water (Ac/Ft)	Water For The Area Under Equity (Ft)	Final Decision Values			
				q (cfs/ft)	T (minutes)	E _r	D _p
1	.11	800	.114	.0020	105.0	1.0	.004
2	.11	800	.114	.0020	105.0	1.0	.004
3	.11	800	.114	.0020	105.0	1.0	.004
4	.38	3100	.441	.00309	262.0	1.0	.061
5	.18	2600	.185	.00259	131.0	.97	.010
6	.17	3500	.166	.00371	87.0	.96	.003
7	.24	5000	.237	.00526	87.0	.93	.014
8	.29	6800	.323	.00695	87.0	.98	.039
9	.36	8800	.418	.00891	87.0	.98	.065
10	.37	9000	.427	.00898	87.0	.96	.072
11	(.39)	9500	.451	.00957	87.0	.96	.077
12	.36	8800	.418	.00891	87.0	.98	.065
13	.36	8800	.418	.00891	87.0	.98	.065
14	.36	8800	.418	.00891	87.0	.98	.065
15	.20	4200	.199	.00436	87.0	.94	.011
16	.14	2700	.128	.00299	87.0	.91	.000
17	.13	2500	.119	.00276	87.0	.92	.0
18	.15	2200	.157	.0022	131.0	1.00	.007
19	.18	1300	.185	.0020	170.0	.99	.007
20	.10	700	.100	.0020	92.0	1.00	.0

Table 5.4.15 - VALUES OF APPLICATION SYSTEM VARIABLES - AREA 3

Irrigation Number	Average Requirement Depth (ft)	Total Reservoir Water (Ac/Ft)	Water For The Area Under Equity (Ft)	Final Decision Values			
				q (cfs/ft)	T (minutes)	E _r	D _p
1	.11	8900	.114	.0020	124.0	1.00	.004
2	.11	800	.114	.0020	124.0	1.00	.004
3	.11	800	.114	.0020	124.0	1.00	.004
4	.38	3100	.441	.00309	309.0	1.00	.061
5	.18	2600	.185	.00259	155.0	1.00	.005
6	.17	3500	.166	.00332	103.0	1.00	.00
7	.24	5000	.237	.00469	103.0	.93	.014
8	.29	6800	.323	.00694	103.0	.96	.045
9	.36	8800	.418	.00928	103.0	.93	.083
10	.37	9000	.427	.00976	103.0	.93	.083
11	(.39)	9500	.451	.00995	103.0	.90	.100
12	.36	8800	.418	.00928	103.0	.93	.083
13	.36	8800	.418	.00928	103.0	.93	.083
14	.36	8800	.418	.00928	103.0	.93	.083
15	.20	4200	.199	.00398	103.0	1.00	.00
16	.14	2700	.128	.00223	103.0	.91	.00
17	.13	2500	.119	.00215	103.0	.92	.00
18	.15	1800	.135	.002	146.0	.90	.00
19	.18	1200	.171	.002	185.0	.95	.00
20	.10	700	.100	.002	109.0	1.00	.00

Table 5.4.16 - VALUES OF APPLICATION SYSTEM VARIABLES - AREA 4

Irrigation Number	Average Requirement Depth (ft)	Total Reservoir Water (Ac/Ft)	Water For The Area Under Equity (Ft)	Final Decision Values			
				q (cfs/ft)	T (minutes)	E _r	D _p
1	.11	800	.114	.0020	14.0	1.0	.004
2	.11	800	.114	.0020	14.0	1.0	.004
3	.11	800	.114	.0020	14.0	1.0	.004
4	.38	3100	.441	.00309	309.0	1.0	.061
5	.18	2600	.185	.00259	155.0	1.0	.005
6	.17	3500	.166	.00244	103.0	1.00	.00
7	.24	5000	.237	.00410	103.0	.96	.007
8	.29	6800	.323	.00587	103.0	.95	.048
9	.36	8800	.418	.00825	103.0	.93	.083
10	.37	9000	.427	.00833	103.0	.92	.087
11	(.39)	9500	.451	.00907	103.0	.92	.092
12	.36	8800	.418	.00825	103.0	.93	.083
13	.36	8800	.418	.00825	103.0	.93	.083
14	.36	8800	.418	.00825	103.0	.93	.083
15	.20	4200	.199	.00379	103.0	1.0	.00
16	.14	2700	.128	.00212	103.0	.91	.00
17	.13	2500	.119	.00204	103.0	.92	.00
18	.15	1900	.135	.0020	146.0	.90	.00
19	.18	1200	.171	.0020	185.6	.95	.00
20	.10	700	.100	.0020	109.0	1.0	.00

5.5 CONCLUSIONS AND RECOMMENDATIONS

The procedure for the determination of the values of the on-farm variables such as unit flow rate, time of application and the length of the field considers the project scale availability of water and optimizes the net benefits from the project area considering equity of water distribution to the different portions of the project. The procedure assumes initial canal parameters for the computation of conveyance efficiencies. Irrigation quality parameter functions for level borders for the cases of SCS infiltration families $I = 0.1, 0.5, 1.0$ and 1.5 have been developed using the Zero-Inertia simulations and similar functions have been developed for the case of furrows using the SCS approach.

Application of the procedure for a hypothetical project indicates the following:

- (i) Length of the farms should be set at their upper limits;
- (ii) time of application is governed by the total time the farmer can spend to irrigate his farm;
- (iii) at the peak demand irrigation, weighing equity distribution by a factor of 0.4 and system net benefit optimality distribution by a factor of 0.6 the maximum difference in flow rates in different portions of the project area is about 10%, and;

- (iv) flow requirements at each farm in any given area over the season range from the lowest value to about 5 times the lowest value.

Relative yield functions using requirement efficiency may be developed for different kinds of crops for the use in farm design. This is suggested for future research. Surface conveyance losses in many systems are relatively high. Systematic study of the conveyance losses and the inclusion of it in the project scale analysis of farm design is suggested for future research. Over the years, the groundwater table movement might show an upward trend.

CHAPTER 6

GROUNDWATER INTERACTION MODULE

6.1 INTRODUCTION

Groundwater flow in irrigated areas is an important process in that its long term effects may be pronounced and may be detrimental to crop growth. A study of groundwater interaction would enable us to evaluate the effects of irrigation system parameters on the water table build up and to decide on the necessity of installing drainage arrangements. The case of return flows or their quantitative and qualitative effects on downstream use are also questions that need to be addressed. While water quality effects are not addressed here, the issues related to water table build up, from which the first order stream return flow computations also can be made, are analyzed in this section.

Since in many cases, especially those in the developing countries, the canals are unlined and seepage of water and the consequent loss of water in conveyance through such canal systems need to be analyzed. The conveyance efficiency computations are necessary for the calculation of water requirements at the source and also for the computations of optimal allocation of water amongst the different portions of the project. Since the main canals from which secondary canals branch off form a boundary, the analysis of water flow from the main canals are needed for boundary condition analysis for the general study of water table build up in the irrigated areas. These two aspects of groundwater interactions in irrigated areas will be the themes of this module.

6.2 LITERATURE REVIEW AND IDEALISATION OF THE WATER TABLE MOVEMENT PROBLEM

A study of ground water interactions with the root zone require soil and geological data as well. However, extensive data collection in this regard would prove to be expensive as would be the determination of the aquifer properties. Numerical ground water modelling could be adopted if all the data on the boundary conditions and on the aquifer properties are available. Bear (1979)) gives a compendium of the finite difference and finite element techniques and Morel-Seytoux and Daly (1975) may be referred for the discrete kernel approach. Numerical modelling would require a good amount of computational resources. Thus, it may be convenient to adopt an idealized approach similar to that of Glover (1978) (page 137).

The one dimensional model of Glover (1978) may be typically modified for our purposes (Please see Figures 6.2.1 & 6.2.2). We will basically view a deterministic process of recharge excitations to the system and will take a linear systems approach (Dooge (1973)).

Let the following be the notation:

- h - the height of water table above the aquiclude
- h_1 - the height of feeder stream above the aquiclude
- h_2 - the height of main canal above the aquiclude
- $P(x,t)$ - the recharge excitation (depth/time)
- x - the horizontal distance from the edge of the stream
- S - the specific yield of the aquifer (average for the slice studied)
- K - the hydraulic conductivity of the aquifer (average for the slice studied)

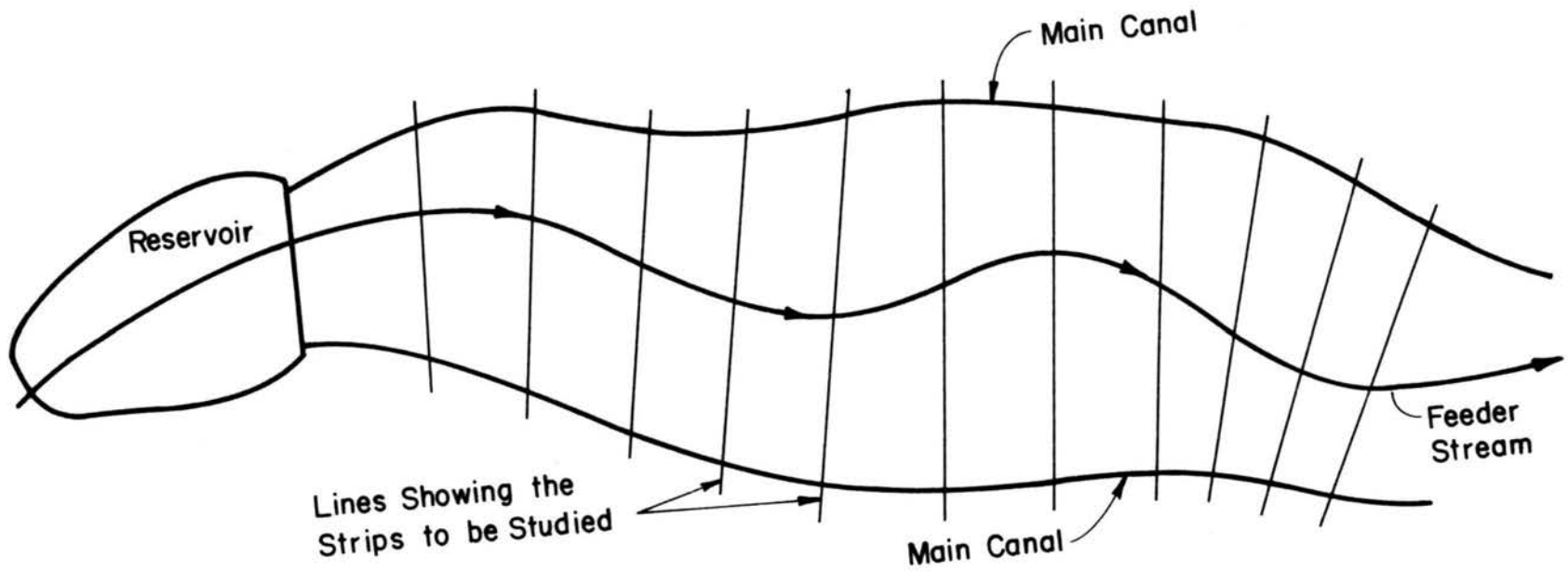

Figure 6.2.1 Plan View Of A Typical Layout

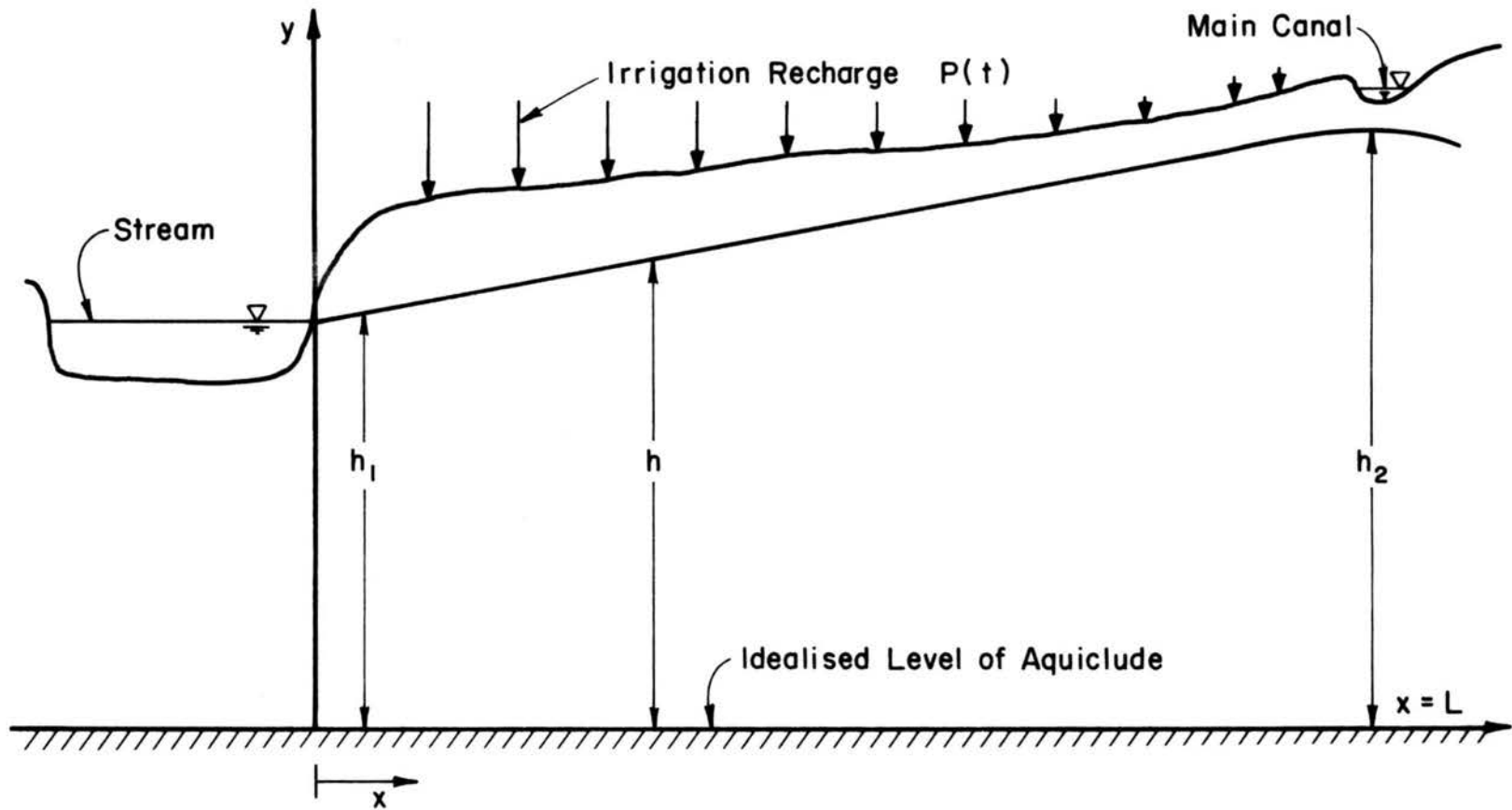

Figure 6.2.2 Cross Sectional View Of Irrigated Area

The Boussinesq Equation (Chapman (1980)) for the general case is given by:

$$K \frac{\partial}{\partial x} \left(h' \frac{\partial h}{\partial x} \right) + P(x,t) = S \frac{\partial h}{\partial t} \quad (6.2.1)$$

where h is the water table height from a given datum and h' is the height of the flow path from the aquiclude. Chauhan et.al. (1968) reported after analytical and analog studies that if the aquiclude slopes are less than 8%, they have a negligible effect on the water table computations. Chapman (1980) modified the basic equations for flow in sloping beds which was found to be good for slopes up to 30° . Considering these two views, it is expedient to work with Equation 6.2.1. for the horizontal idealization of the aquiclude for slopes up to 8% and for slopes greater than 8% to resort to Chapman's equation (Chapman (1980)). Since it is conjectured that many situations will be covered by the 8% slope limitation and since the inclusion of the slope term complicates the solutions, the horizontal aquiclude case will be studied here.

Thus in Equation 6.2.1 we will analyze the case of h' being a constant with an average height of D (Maasland (1959), Werner (1957), Dumm (1964) and Dumm and Winger (1964)). Thus, the linearized Boussinesq Equation in the present case is:

$$KD \frac{\partial^2 h}{\partial x^2} + P(x,t) = S \frac{\partial h}{\partial t} \quad (6.2.2)$$

On rearranging we obtain,

$$\frac{\partial^2 h}{\partial x^2} - \frac{S}{KD} \frac{\partial h}{\partial t} = - \frac{P(x,t)}{KD} \quad (6.2.3)$$

On setting $a = \frac{S}{KD}$ and

$$b = \frac{1}{KD},$$

we have,

$$\frac{\partial^2 h}{\partial x^2} - a \frac{\partial h}{\partial t} = -b P(x, t) \quad (6.2.4)$$

Boundary Conditions

When finding the solution of the linear equation, Equation 2.4, we need to incorporate suitable boundary conditions. We will assume that at $x = 0$, $h = h_1$ for $t \geq 0$ and at $x = L$, $h = h_2(t)$ for $t > 0$. We will neglect the stage heights both in the feeder stream and the main canal. We will also assume that the initial water table profile passes through the point $(0, h_1)$. The variation of $h_2(t)$ with t depends on the main canal parameters and the study of the problem will be given subsequently.

Let us adopt the following transformation (Daly (1979)) to simplify Equation 6.2.4

$$\bar{h} = h - h_1 - \frac{x}{L} (h_2 - h_1) \quad (6.2.5)$$

This leads to when substituted in 6.2.4,

$$\frac{\partial^2 \bar{h}}{\partial x^2} - a \frac{\partial \bar{h}}{\partial t} = -b P(x, t) \quad (6.2.6)$$

with following boundary conditions,

$$\text{B.C.1 } \bar{h}(0, t) = 0 \text{ for } t \geq 0$$

$$\text{B.C.2 } \bar{h}(L, t) = 0 \text{ for } t > 0 \text{ and}$$

$$\text{B.C.3 } \bar{h}(x, 0) = \sigma(x)$$

B.C.3 translates into,

at $t = 0$,

$$h = \left[h_1 + \frac{x}{L} (h_2 - h_1) + \sigma(x) \right] \quad (6.2.7)$$

In a general case $\sigma(x) > 0$.

6.3 SOLUTION APPROACH - GREEN'S FUNCTIONS

6.3.1 Green's Function for the Homogeneous Problem

In finding a solution to the non-homogeneous equation

$$\frac{\partial^2 \bar{h}}{\partial x^2} - a \frac{\partial \bar{h}}{\partial t} = -b P(x,t) \quad (6.3.1)$$

with the previously prescribed boundary conditions the classical Green's functions approach is followed here. (Carslaw and Jaeger (1959), Roach (1982), Özisik (1980)).

The auxiliary homogeneous version of the above problem is given by

$$\frac{\partial^2 \psi}{\partial x^2} = a \frac{\partial \psi}{\partial t} \quad (6.3.2)$$

with the boundary conditions

$$\psi(0, t) = \psi(L, t) = 0 \text{ and}$$

$$\psi(x, 0) = \sigma(x)$$

The general solution of the above equation is given by (Özisik (1980)),

$$\psi(x,t) = \frac{2}{L} \sum_{n=1}^{\infty} \left\{ \exp(-n^2 \pi^2 t / (aL^2)) \sin(n \pi x / L) \int_0^L \sin(n \pi y / L) \sigma(y) dy \right\} \quad (6.3.3)$$

Let the Green's function of the B V problem be $G(x, y, t, \tau)$. Then,

$$\psi(x, t) = \int_0^L G(x, y, t, \tau) \Big|_{\tau=0} \sigma(y) dy \quad (6.3.4)$$

On comparing Equations 5.3.3 and 5.3.4,

$$G(x, y, t, \tau) = \frac{2}{L} \sum_{n=1}^{\infty} e^{-\frac{n^2 \pi^2}{aL^2} (t-\tau)} \sin\left(\frac{n \pi x}{L}\right) \sin\left(\frac{n \pi y}{L}\right) \quad (6.3.5)$$

6.3.2 Convolution for General Excitation $P(t)$

The response due to a general recharge excitation $P(t)$ is given by

(Carslaw and Jaeger (1959) and Özisik (1980))

$$h(x, t) = \frac{2}{L} \sum_{n=1}^{\infty} e^{-\frac{n^2 \pi^2 t}{aL^2}} \sin\left(\frac{n \pi x}{L}\right) \int_0^L \sigma(y) \sin\left(\frac{n \pi y}{L}\right) dy$$

$$+ \frac{2b}{2L} \sum_{n=1}^{\infty} e^{-\frac{n^2 \pi^2 t}{aL^2}} \sin\left(\frac{n \pi x}{L}\right) \int_0^t e^{-\frac{n \pi^2 \tau}{aL^2}} d\tau \left(\int_0^L \sin\left(\frac{n \pi y}{L}\right) \right.$$

$$P(\tau) dy \Big) - \frac{2}{aL} \sum_{n=1}^{\infty} (-1)^n e^{-\frac{n^2 \pi^2 t}{aL^2}} \left(\frac{n\pi}{L}\right) \sin\left(\frac{n \pi x}{L}\right)$$

$$\int_0^t e^{-\frac{n^2 \pi^2 \tau}{aL^2}} h_2(\tau) d\tau \quad (6.3.6)$$

On rearranging,

$$\bar{h}(x, t) = \frac{4b}{a\Lambda} \sum_{n=1,3,5}^{\infty} \frac{1}{n} \left[\sin\left(\frac{n\pi x}{L}\right) \int_0^t e^{-\frac{n^2\pi^2}{aL^2}(t-\tau)} P(\tau) d\tau \right] + T_1 + T_2 \quad (6.3.7)$$

where,

$$T_1 = (2/L) \sum_{n=1}^{\infty} e^{-\frac{n^2\pi^2 t}{aL^2}} \sin(n\pi x/L) \int_0^L \sigma(y) \sin(n\pi y/L) dy \quad (6.3.8)$$

and

$$T_2 = (2/aL) \sum_{n=1}^{\infty} (-1)^n \exp(-n^2\pi^2 t/aL^2) (n\pi/L) \sin(n\pi x/L) \int_0^t \exp(n^2\pi^2\tau/aL^2) h_2(\tau) d\tau$$

It may be noted that the first component of $\bar{h}(x, t)$ is similar to the Glover solution (See Maasland (1959) and McWhorter (1977)) and the second component, T_1 , is due to the dissipation of the initial water table and T_2 is due to mound height build up below the main canal. These results compare with the results of Singh and Jacob (1977) and Sagar (1979).

6.4 EFFECTS OF RECHARGE DUE TO IRRIGATION ON WATER TABLE

6.4.1 A Finite Fourier Representation of Recharge Events

Recharge to the water table occurs in irrigation areas due to deep percolation. The amount that deep percolates depends on the hydraulic

conditions that exist during an irrigation. Flow rates, time of application, size of the fields and the soil characteristics are factors that determine deep percolation. This will be analyzed when determining the actual values but for the present the general model will be presented.

Let the recharge rates be sampled at the interval, Δ , of one month and let the period, T , over which this is repeated, be 12 months. Then the recharge function $P(t)$ is given by (Jenkins and Watts (1968)).

$$P(t) = A_0 + \sum_{m=1}^5 A_m \cos\left(\frac{2\pi mt}{T}\right) + B_m \sin\left(\frac{2\pi mt}{T}\right) + A_e \cos(\pi t) \quad (6.4.1)$$

where

$$A_0 = \frac{1}{12} \sum_{i=1}^{12} \rho_i \quad (6.4.2)$$

$$A_m = \frac{1}{12} \sum_{r=0}^{11} \rho_r \cos\left(\frac{2\pi mr}{12}\right) \quad m = 1, 2, \dots, 6 \quad (6.4.3)$$

$$B_m = \frac{1}{12} \sum_{r=0}^{11} \rho_r \sin\left(\frac{2\pi mr}{12}\right) \quad m = 1, 2, \dots, 5 \quad (6.4.4)$$

where ρ_j is the average recharge for month j .

$P(t)$ can be modified as

$$P(t) = A_0 + A_e \cos \pi t + \sum_{m=1}^5 D_m \sin(W_m t + \phi_m) \quad (6.4.5)$$

where

$$\tan \phi_m = \frac{A_m}{B_m}, \quad (6.4.6)$$

$$D_m = \sqrt{A_m^2 + B_m^2} \quad \text{and} \quad (6.4.7)$$

$$W_m = \frac{2\pi m}{T} \quad (6.4.8)$$

6.4.2 General Solution with P(t) Due To Irrigation

Using the finite Fourier representation $P(t)$ derived previously in the expression for $h(x, \tau)$ we have for the term due to recharge (let this be $\bar{h}_r(x, \tau)$),

$$\begin{aligned} \bar{h}_r(x, t) = & \frac{4b}{a\pi} \sum_{n=1,3,5}^{\infty} \frac{1}{n} \sin\left(\frac{n\pi x}{L}\right) \int_0^t e^{-\frac{n^2\pi^2}{aL^2}(t-\tau)} (A_0 + A_0 \cos \pi \tau) \\ & + \sum_{m=1}^5 D_m \sin(W_m \tau + \phi_m) d\tau \end{aligned} \quad (6.4.9)$$

Let

$$\mu = \mu(n) = \frac{n^2\pi^2}{aL^2} \quad \text{and} \quad (6.4.10)$$

$$f_s = f_s(n, x) = \frac{1}{n} \sin \frac{n\pi x}{L} \quad (6.4.11)$$

Considering the first term of convolution in $h(x, \tau)$ we have

$$A_0 \int_0^t e^{-\mu(t-\tau)} d\tau = \frac{A_0}{\mu} (1 - e^{-\mu t}) \quad (6.4.12)$$

Now consider the integral

$$I = \int_0^t e^{-\mu(t-\tau)} e^{i(W\tau + \phi)} d\tau \quad (6.4.13)$$

This integral is given by

$$\begin{aligned} \sqrt{\mu^2 + w^2} I &= \sin (wt + \phi + \lambda) - e^{-\mu t} \sin (\lambda + \phi) \\ &- i [\cos (wt + \phi + \lambda) - e^{-\mu t} \cos (\lambda + \phi)] \end{aligned} \quad (6.4.14)$$

where $\tan \lambda = \mu/w$.

$$\begin{aligned} &\int_0^t e^{-\mu(t-\tau)} \sin (w\tau + \phi) d\tau \\ &= \frac{e^{-\mu t} \cos (\lambda + \phi) - \cos (wt + \lambda + \phi)}{\sqrt{(\mu^2 + w^2)}}, \end{aligned} \quad (6.4.15)$$

and

$$A_6 \int_0^t e^{-\mu(t-\tau)} \cos \tau \pi d\tau = A_6 \frac{(\sin (t + \lambda_0) - e^{-\mu t} \sin \lambda)}{\sqrt{\mu^2 + w^2}} \quad (6.4.16)$$

where $\tan \lambda_0 = \mu/\pi$.

Considering the term,

$$\begin{aligned} &\int_0^t e^{-\frac{n^2 \pi^2 (\tau-t)}{aL^2}} \left(\sum_{m=1}^5 D_m \sin (w_m t + \phi_m) \right) d\tau \\ &= \sum_{m=1}^5 \frac{D_m}{\sqrt{\mu^2 + w_m^2}} e^{-\mu t} \cos (\lambda_m + \phi_m) - \cos (w_m t + \lambda_m + \phi_m) \end{aligned} \quad (6.4.17)$$

where $\tan \lambda_m = \frac{\mu}{w_m}$

$$\begin{aligned}
 \bullet \bullet \bar{h}_r(x, t) &= \frac{4b}{a\pi} \sum_{n=1,3,5}^{\infty} \frac{A_0}{\mu} (1 - e^{-\mu t}) f_s \\
 &+ \frac{4b}{a\pi} \sum_{n=1,3}^{\infty} \frac{A_6}{\sqrt{\mu^2 + \pi^2}} (\sin(\pi t + \lambda_0) - e^{-\mu t} \sin \lambda_0) f_s \\
 &+ \frac{4b}{a\pi} \sum_{m=1}^5 D_m \left[\sum_{n=1,3}^{\infty} \frac{\cos(w_m t + \phi_m + \lambda_m) - e^{-\mu t} \cos(\lambda_m + \phi_m)}{\sqrt{\mu^2 + w_m^2}} f_s \right]
 \end{aligned}
 \tag{6.4.18}$$

where

$$\tan \lambda_0 = \frac{\mu}{\pi},$$

For large $t = T$, $e^{-\mu T} \rightarrow 0$ and

$$\begin{aligned}
 \bar{h}_r(x, T) &= \frac{4b}{a\pi} \sum_{n=1,3,5}^{\infty} \frac{A_0}{\mu} f_s \\
 &+ \frac{4b}{a\pi} \sum_{n=1,3}^{\infty} \frac{A_6}{\sqrt{\mu^2 + \pi^2}} \sin(\pi T + \lambda_0) f_s \\
 &+ \frac{4b}{a\pi} \sum_{m=1}^5 D_m \left[\sum_{n=1,3}^{\infty} \frac{\cos(w_m T + \phi_m + \lambda_m)}{\sqrt{\mu^2 + w_m^2}} f_s \right]
 \end{aligned}
 \tag{6.4.19}$$

Now $h(x, t)$ for large t , $h_f(x, t)$ is given by

$$\begin{aligned}
 h_f(x, t) = & h_1 + \frac{x}{L} (h_2 - h_1) \\
 & + \frac{4b}{a\pi} A_0 \sum_{n=1,3}^{\infty} \frac{(f_s)}{\mu} + \frac{4b}{a\pi} A_6 \sum_{n=1,3,5}^{\infty} \frac{\sin(\pi t + \lambda_0) f_s}{\sqrt{\mu^2 + \pi^2}} \\
 & + \frac{4b}{a\pi} \sum_{m=1}^5 D_m \sum_{n=1,3}^{\infty} \left[\frac{\cos(w_m t + \phi_m + \lambda_m) f_s}{\sqrt{\mu^2 + w_m^2}} \right] + T_2(t) \quad (6.4.20)
 \end{aligned}$$

As will be seen, the above equation for large t contains non-oscillating terms and oscillating terms and the former reflects the final equilibrium at which dynamic equilibrium exists if $T_2(t)$ is bounded (Maasland (1964), McWhorter (1977)).

Thus,

$$\begin{aligned}
 h_f(x, t) = & h_1 + \frac{x}{L} (h_2 - h_1) + \frac{4bL^2}{\pi^3} A_0 \sum_{n=1,3}^{\infty} \frac{1}{n^3} \sin \frac{n\pi x}{L} \\
 & + \frac{4(bL^2)}{\pi^2} A_6 \sum_{n=1,3}^{\infty} \frac{\sin(\pi t + \lambda_0)}{n \sqrt{(n^4 \pi^2 + a^2 L)^4}} \sin \left(\frac{n\pi x}{L} \right) \\
 & + \frac{4(bL^2)}{\pi} \sum_{m=1}^5 \sqrt{A_m^2 + B_m^2} \sum_{n=1,3,5}^{\infty} \frac{1}{n} \frac{\cos(w_m t + \phi_m + \lambda_m)}{\sqrt{n^4 \pi^2 + a^2 L^4 \frac{m^2}{36}}} \\
 & \sin \left(\frac{n\pi x}{L} \right) + T_2(t) \quad (6.4.21)
 \end{aligned}$$

It may be noted that the series in the third term in the above is summable and is given by $L (A_0/2) (L-x)$ which agrees with the steady state solution.

6.5 HEAD VARIATIONS UNDER THE MAIN CANAL

6.5.1 Flow Until Hydraulic Connection

Abdulrazzak (1982) has recently studied the head variations under ephemeral streams for the case of sudden stepping up of water level in them. However, this work did not include the study of the dissipation of head once the flow stops - a case that is closer to the reality of a canal system which is shut down after an irrigation season. To obtain the general variation of $h_2(t)$ with t , the study of Abdulrazzak (1982) has to be extended for the case of the dissipation of the mound height beneath a canal after the water is shut down. The study of Abdulrazzak (ibid) used the Green and Ampt equation for the case of wetting front traveling towards the water table. At the time of hydraulic connection between the water table and the wetting front, the unit length flow rate through a half of the canal is given by

$$q_0 = K W \frac{(H + D')}{D'} \quad (6.5.1)$$

where K is the saturated hydraulic conductivity of aquifer, W is the semi bed width of the canal and D' the depth to the water table from the canal bed. The time taken to reach the water table, t_a , can be given by (Hart and Corey (1976)).

$$t_a = \frac{(\theta_a - \theta_i)}{K_a} \left[D' - (H + h_f) \ln \left(1 + \frac{D'}{H + h_f} \right) \right] \quad (6.5.2)$$

where θ_a is the soil moisture content of the wetting front which can be taken approximately as equal to 80 - 90% of the porosity of the soil, K_a the average soil conductivity above the wetting front and h_f is the suction head at the wetting front. The non dimensionalized time

$$t^* = K_a t_a / (\theta_a - \theta_i) H \text{ and} \quad (6.5.3)$$

the non-dimensionlized flow q_0/kw are given in Figure 6.5.1 as function of non-dimensionlized depth D'/H .

As an example in a reach of canal passing through a soil in which, $2\theta_i \approx \theta_a \approx 0.50$ with a saturated hydraulic conductivity of 1.0 ft/day where the water table is 10 times deep as the head of the water in the canal (3 ft), it would take 5.25 days for the water to reach the water table.

6.5.2 Flow After Hydraulic Connection

Once the hydraulic connection is established the rise of height of water table beneath the canal is given by (Abdulrazzak (1982))

$$h(t) = (D'+H) \left[1 - \exp\left(\frac{q_0^2 kt}{[T(D'+H)]^2}\right) \operatorname{erfc}\left(\frac{q_0(kt)^{1/2}}{T(D'+H)}\right) \right] \quad (6.5.4)$$

where

$$T = KD \text{ and } k = KD/S$$

i.e.

$$h(t) = (D' + H) \left(1 - \exp\left(\frac{q_0^2 kt}{T(D'+H)}\right) \operatorname{erfc}\left(\frac{q_0 kt}{T(D'+H)}\right) \right) \quad (6.5.5)$$

The general distribution of head along a plane across the canal is given by

$$h(x,t) = (D'+H) \operatorname{erfc} \frac{x}{2\sqrt{kt}} - \exp q_0 s/T (D'+H) \exp q_0^2 kt/(T(D'+H))^2 \operatorname{erfc} \frac{q_0 kt}{T (D'+H)} + \frac{x}{2\sqrt{kt}} \quad (6.5.6)$$

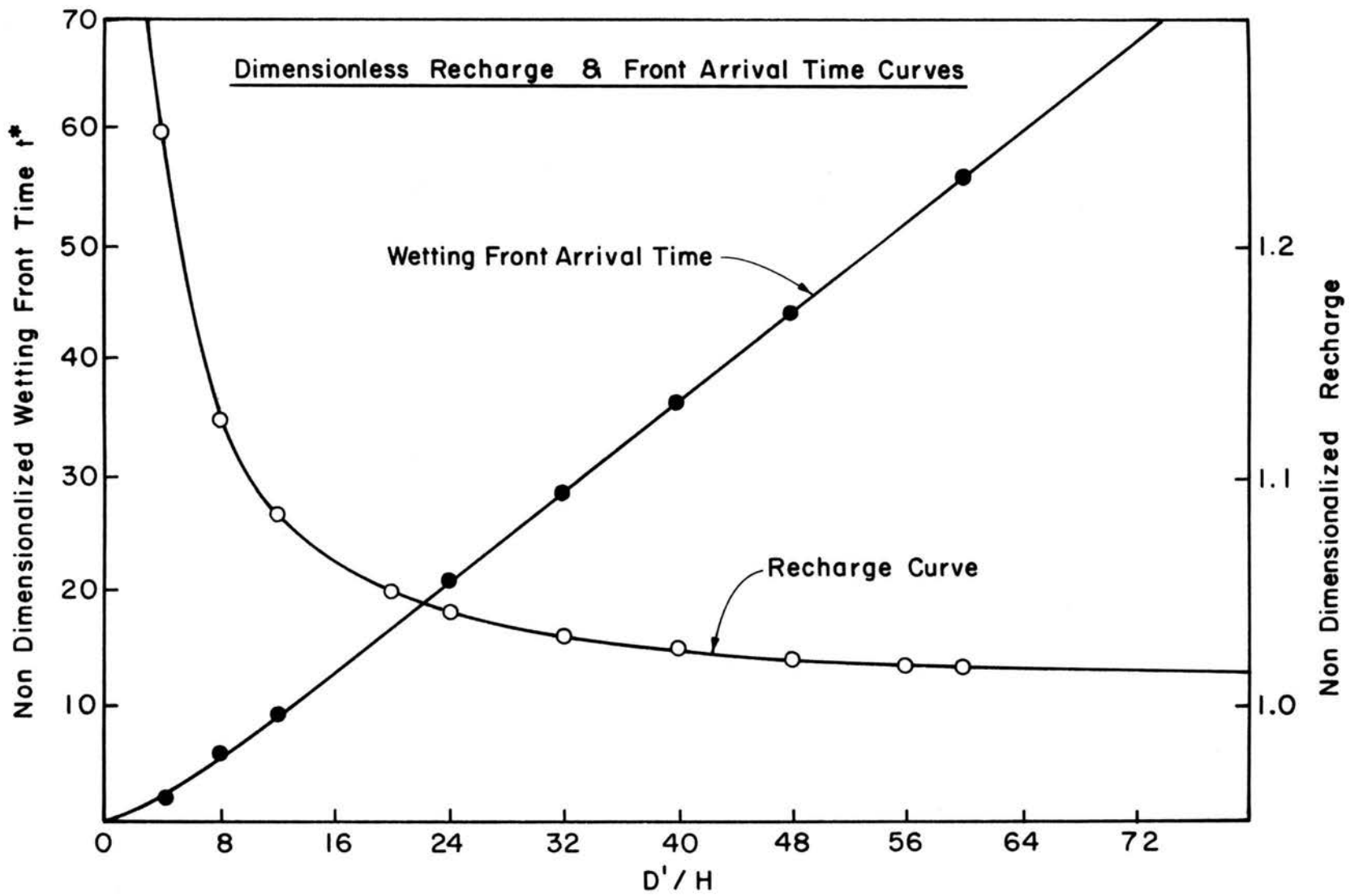

Figure 6.5.1 Dimensionless Recharge And Front Arrival Time Curves

Let the canal flow be shutoff after t_0 . The dissipation of the mound height after time t_0 may be obtained by solving

$$\frac{\partial^2 h}{\partial x^2} = \frac{1}{k} \frac{\partial h}{\partial t} \quad (6.5.7)$$

with the boundary conditions:

- (i) that the initial head distribution is $h(x, t_0)$ and
- (ii) that the flow is divided symmetrically and there is no flow across the centerline of the main canal. (the so-called boundary conditions of Type - 2).

$$\begin{aligned} h(x, t_0) &= h_0(x, t_0) \\ &= \beta_0 [\operatorname{erfc}(\alpha_1 x) - \beta_1 \exp(\alpha_2 x) \operatorname{erfc}(\alpha_3 + \alpha_1, x)] \end{aligned} \quad (6.5.8)$$

where

$$\beta_0 = (D' + H)$$

$$\beta_1 = \exp(q_0^2 kt_0 / (T(D' + H))^2),$$

$$\alpha_1 = \frac{1}{2 kt_0},$$

$$\alpha_2 = q_0 / T(D' + H) \quad \text{and}$$

$$\alpha_3 = (\ln \beta_1)^{1/2}$$

The solution of the Equation

$$\frac{\partial^2 h}{\partial x^2} = \frac{1}{k} \frac{\partial h}{\partial t} \quad (6.5.10)$$

considering that the flow domain is semi infinite is given by

$$h(x, t) = \int_{\xi=0}^{\infty} e^{-k \xi^2 t} \frac{1}{N(\xi)} X(\xi, x) \int_{\lambda}^{\infty} X(\xi, \lambda) h_0(\lambda, t_0) d\lambda d\xi \quad (6.5.11)$$

where X is the eigen function and N the norm of the eigen value problem

$$\frac{d^2 X}{dx^2} + \beta^2 X = 0 \quad (6.5.12)$$

with the appropriate boundary conditions. In our case we assume no flow at $x=0$ (that is the boundary condition of type - 2). For this case

$$N(\xi) = \frac{\pi}{2} \text{ and } X(\xi, n) = \text{Cos } \xi x \quad (6.5.13)$$

(from Özisik (1980)).

On rearranging the above integral

$$h(x, t) = \frac{2}{\pi} \int_0^{\infty} h_0(\lambda, t_0) \int_0^{\infty} e^{-k \xi^2 t} \text{Cos } \xi x \text{ Cos } \xi \lambda d\xi d\lambda \quad (6.5.14)$$

Since, $2 \text{ Cos } \xi n \text{ Cos } \xi \lambda = \text{Cos } (x+\lambda) \xi + \text{Cos } (n-\lambda) \xi$ and using the result

$$\int_0^{\infty} e^{-k \xi^2 t} \text{Cos } \xi (x + \lambda) d\xi = \frac{\pi}{4kt} \exp \frac{-(x + \lambda)^2}{4kt}, \quad (6.5.15)$$

we have for $h(x, t)$

$$h(x, t) = \frac{1}{\sqrt{4\pi kt}} \int_0^{\infty} h_0(\lambda, t_0) \left[\exp \eta_1 + \exp \eta_2 d\lambda \right] \quad (6.5.16)$$

where

$$\left. \begin{aligned} \eta_1 &= -(x - \lambda)^2 / 4kt \quad \text{and} \\ \eta_2 &= -(x + \lambda)^2 / 4kt \end{aligned} \right\} \quad (6.5.17)$$

Thus, the height of water table below the canal is given by

$$h(o,t) = \frac{1}{\sqrt{\pi kt}} \int_0^\infty h_o(\lambda, t_o) \exp\left(-\frac{\lambda^2}{4kt}\right) d\lambda \quad (6.5.18)$$

Using the expression for $h_o(\lambda, t)$ we have

$$h(o,t) = \frac{\beta_o}{\sqrt{\pi kt}} \int_0^\infty \left([\operatorname{erfc}(\alpha_1 \lambda) - \beta \exp(\alpha_2 \lambda) \operatorname{erfc}(\alpha_3 + \alpha_1 \lambda)] \exp\left(-\frac{\lambda^2}{4kt}\right) \right) d\lambda \quad (6.5.19)$$

This could be integrated using the Gauss - Laguerre quadrature, the abscissae and the weights of which could be obtained from Abramowitz and Stegun (1972). The result is given by

$$h(o,t) = \frac{1}{\sqrt{\pi kt}} \sum_{i=1}^{N_q} W_i h_o(\lambda_i, t_o) \exp\left(-\frac{\lambda_i^2}{4kt}\right) \quad (6.5.20)$$

Where N_q is the number of quadrature points. It may be seen that as $t \rightarrow \infty$, $h(o, t) \rightarrow o$ in the above expression. It may also be seen that $\partial h / \partial t(o, t)$ reduces as t increases.

Thus, at the time of beginning of the new irrigation season transients would still remain. In order to analyze the long term effects of an on and off operation in the main canal, the Abdulrazzak (1982) formula may be used in conjunction with the above formula adjusting for new D' and T using the

residual water table conditions at the beginning of a canal operation. An example of this procedure is given in Figure 6.5.2. Appendix A 6.1 give the variation of head under the main canals. Thus, in the expression for $h_f(x, \tau)$, $h_2(\tau)$ may be replaced by the average height function below the main canal during the expected average life period of the project. The application of this approach both for the evaluation of deep percolation limits and the evaluation of the final water table level will be given subsequently.

Noting that A_0 is the average rate of recharge for period $T=12$ months it is seen from Equation 6.4.21 that the final equilibrium level depends on the average recharge but not on its pattern of distribution over the year. Once the final water table level is computed this in itself will indicate the necessity for drainage arrangements. The amplitude of the oscillatory components in conjunction with the interval of time during which the water table stays above satisfactory limits (Doorenbos and Pruitt (1977) and Durnford (1982)) can also be attempted to be lowered by controlling the recharge amounts.

6.6 APPLICATION OF THE SOLUTION APPROACH

6.6.1 Project Details

The approach described in the previous chapters was applied for the project area the details of which are given in Chapter 5. The project area has been divided into 7 different sections of different ground water movement parameters. The details of these sections are given in Table 6.6.1. The soil group numbers coincide with the soil groups identified in Chapter 5, for the determination of optimal farm design variables. Table 6.6.2 gives the details of the recharge events that are due to deep percolation. Table 6.6.3 and 6.6.4 give the data for the boundary condition analysis. The initial water table profiles are linear with a mild slope towards the feeder stream.

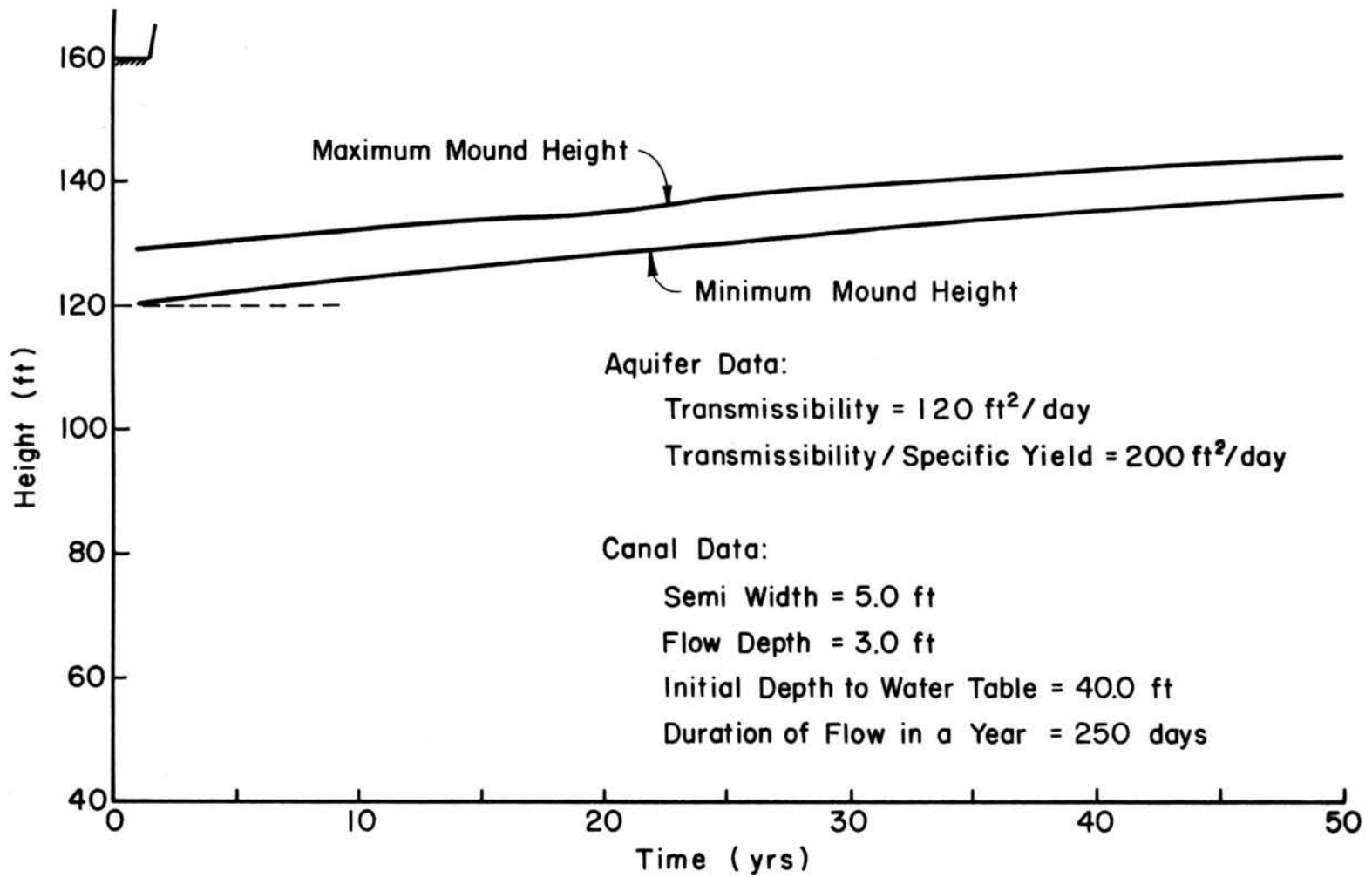

Figure 6.5.2 Water Table Fluctuations Below A Main Canal

6.6.2 Formula For The Case For Given Initial Water Table Profile

For the linear case of initial water table with a slope of σ , the head variation will be given by

$$h(x, \tau) = \bar{h}(x, \tau) + h_1 + \frac{x}{L} (h_2 - h_1) \quad (6.6.1)$$

where

$$\begin{aligned} h(x, \tau) = & \frac{4b}{a\pi} \sum_{n=1,3,5}^{\infty} \frac{A_0}{\mu} f_s (1 - e^{-\mu\tau}) \\ & + \frac{4b}{a\pi} \sum_{n=1,3,5}^{\infty} \frac{A_b}{\sqrt{\mu^2 + \pi^2}} (\sin(\pi t + \lambda_0) - e^{-\mu\tau} \sin \lambda_0) f_s \\ & + \frac{4b}{a\pi} \sum_{m=1}^5 D_m \sum_{n=1,3}^{\infty} \frac{\cos(w_m t + \phi_m + \lambda_m) - e^{-\mu\tau} \cos(\lambda_m + \phi_m)}{\sqrt{\mu^2 + w_m^2}} f_s \\ & - \frac{2\sigma L}{\pi} \sum_{n=1}^{\infty} (-1)^n e^{-\mu\tau} f_s + \frac{2}{\pi} \sum_{n=1}^{\infty} (-1)^n e^{-\mu\tau} f_s \left(\int_0^{\tau} e^{\mu\tau} \frac{\partial h_2}{\partial \tau} d\tau \right) \end{aligned} \quad (6.6.2)$$

6.6.3 Results

The envelope curves for water table movement after 40 years and 60 years of operation are given in Figures 6.6.1 to 6.6.7. The ground surface profiles have been approximated by straight lines. For the analysis of the variation of $h_2(t)$ at the right hand boundary, the canal system is assumed to be on for 240 days and off for 125 days. The end of the year adjustment on the water table for this analysis is obtained from neglecting the last term in Equation 6.6.2.

TABLE 6.6.1

PROJECT GROUND WATER HYDRAULIC PARAMETERS

Main Canal System #	Soil Group #	Recharge Length L (ft)	Hydraulic Conductivity K(ft/hr)	Specific Yield (S_{ya})	Average Initial Saturated Depth D (ft)	Initial Water Table Profile $\sigma(x)$ above h (1)
1	1	10800.0	0.50	0.24	220.0	$(9.26 \times 10^{-4})x$
1	2	9600.0	0.60	0.30	200.0	$(1.04 \times 10^{-3})x$
1	3	8200.0	0.80	0.28	180.0	$(1.22 \times 10^{-3})x$
1	4	8600.0	0.42	0.32	160.0	$(1.16 \times 10^{-3})x$
2	1	8200.0	0.50	0.27	110.0	$(1.46 \times 10^{-3})x$
2	2	7000.0	0.60	0.18	100.0	$(1.43 \times 10^{-3})x$
2	2'	7400.0	0.60	0.18	70.0	$(1.35 \times 10^{-3})x$

TABLE 6.6.2
RECHARGE DEPTHS DUE TO DEEP PERCOLATION

Irrigation Number	DEEP PERCOLATION DEPTH (ft)			
	Soil Group 1	Soil Group 2	Soil Group 3	Soil Group 4
1	.008	.004	.004	.004
2	.008	.004	.004	.004
3	.008	.004	.004	.004
4	.072	.061	.031	.061
5	.021	.010	.005	.005
6	.006	.003	.000	.000
7	.021	.014	.014	.007
8	.048	.039	.045	.048
9	.080	.065	.083	.083
10	.079	.072	.083	.087
11	.088	.077	.100	.092
12	.080	.065	.083	.083
13	.080	.065	.083	.083
14	.080	.065	.083	.083
15	.017	.011	.000	.000
16	.002	.000	.000	.000
17	.002	.000	.000	.000
18	.016	.007	.000	.000
19	.018	.007	.000	.000
20	.007	.000	.000	.000

TABLE 6.6.3
 MAIN CANAL BOUNDARY CONDITION ANALYSIS

SYSTEM 1	DATA Main Canal Flow Duration: 240 Days			
Soil Group #	Average Initial Depth To Water Table (ft)	Initial Saturated Thickness (ft)	Average Initial Design Width Of Canal (ft)	Average Initial Design Depth Of Flow (ft)
1	58.67	120.0	14.60	4.83
2	51.0	100.0	18.50	5.50
3	51.67	80.0	12.0	4.00
4	34.50	60.0	7.50	2.63

TABLE 6.6.4
 MAIN CANAL BOUNDARY CONDITION ANALYSIS

SYSTEM 2	DATA Main Canal Flow Duration: 240 Days			
Soil Group #	Average Initial Depth To Water Table (ft)	Initial Saturated Thickness (ft)	Average Initial Design Width Of Canal (ft)	Average Initial Design Depth Of Flow (ft)
1	44.0	220.0	11.0	3.94
2	48.0	200.0	14.0	4.67
2'	40.5	170.0	6.5	2.50

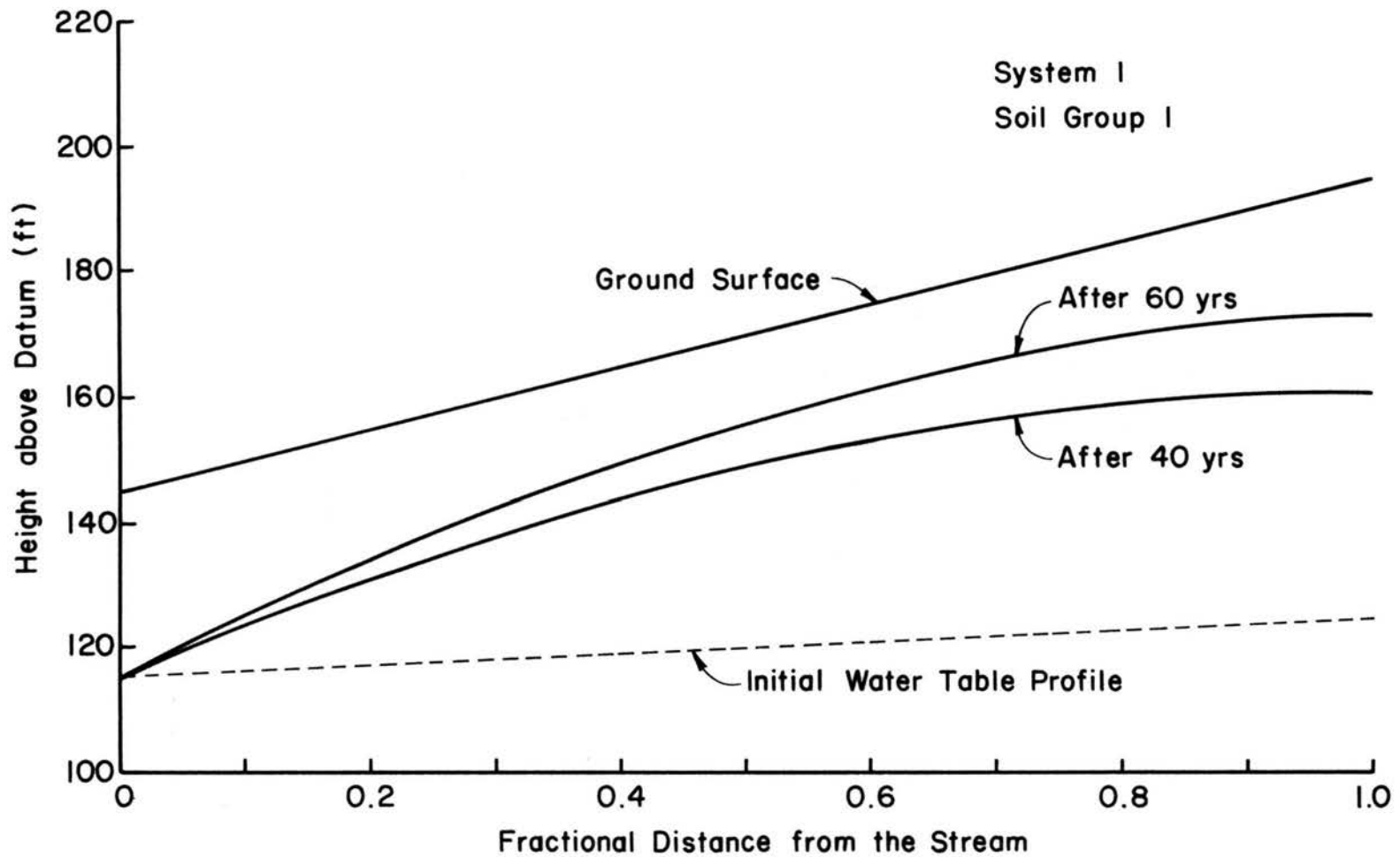

Figure 6.6.1 Water Table Envelope Curves For System 1, Soil Group 1

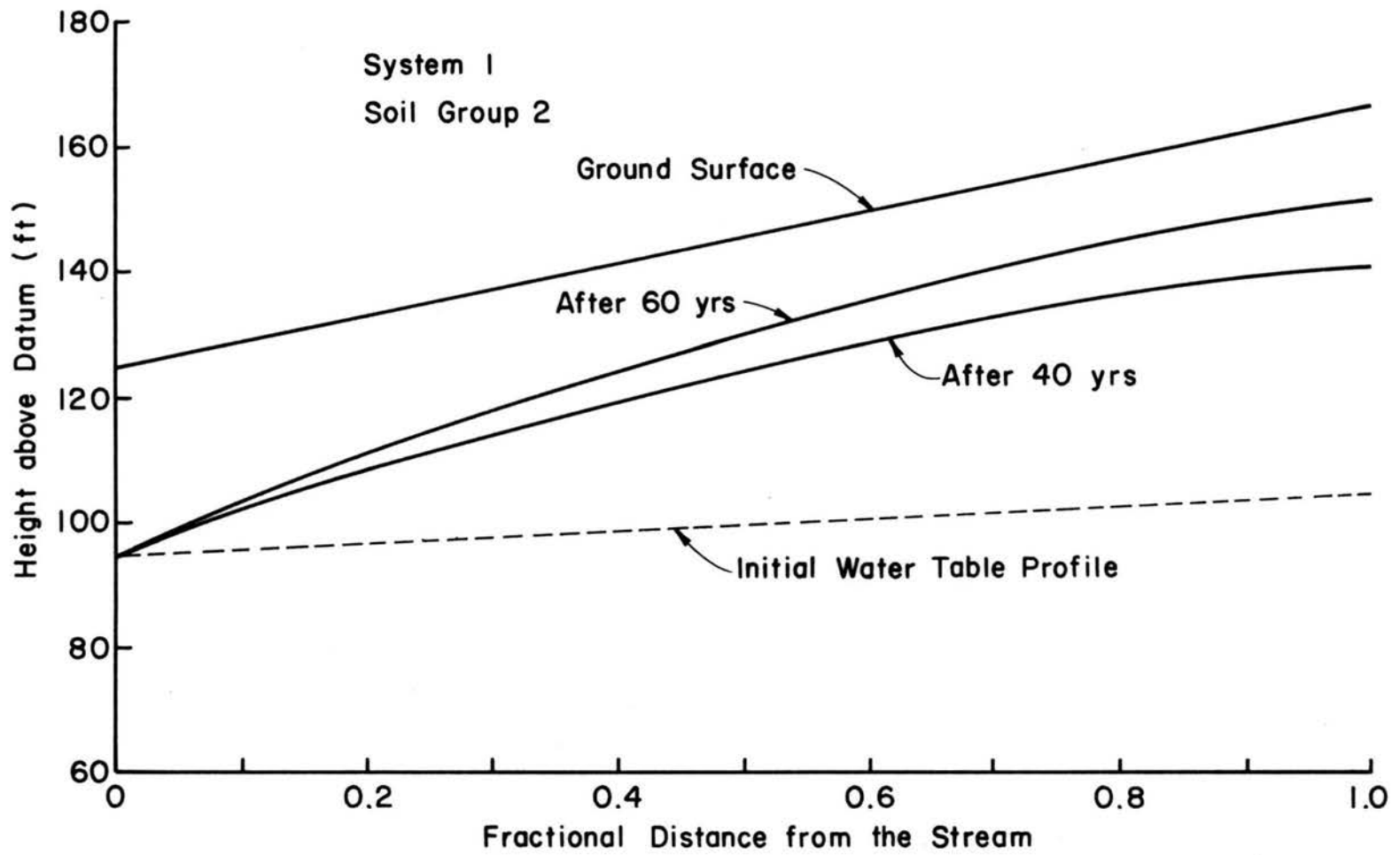

Figure 6.6.2 Water Table Envelope Curves For System 1, Soil Group 2

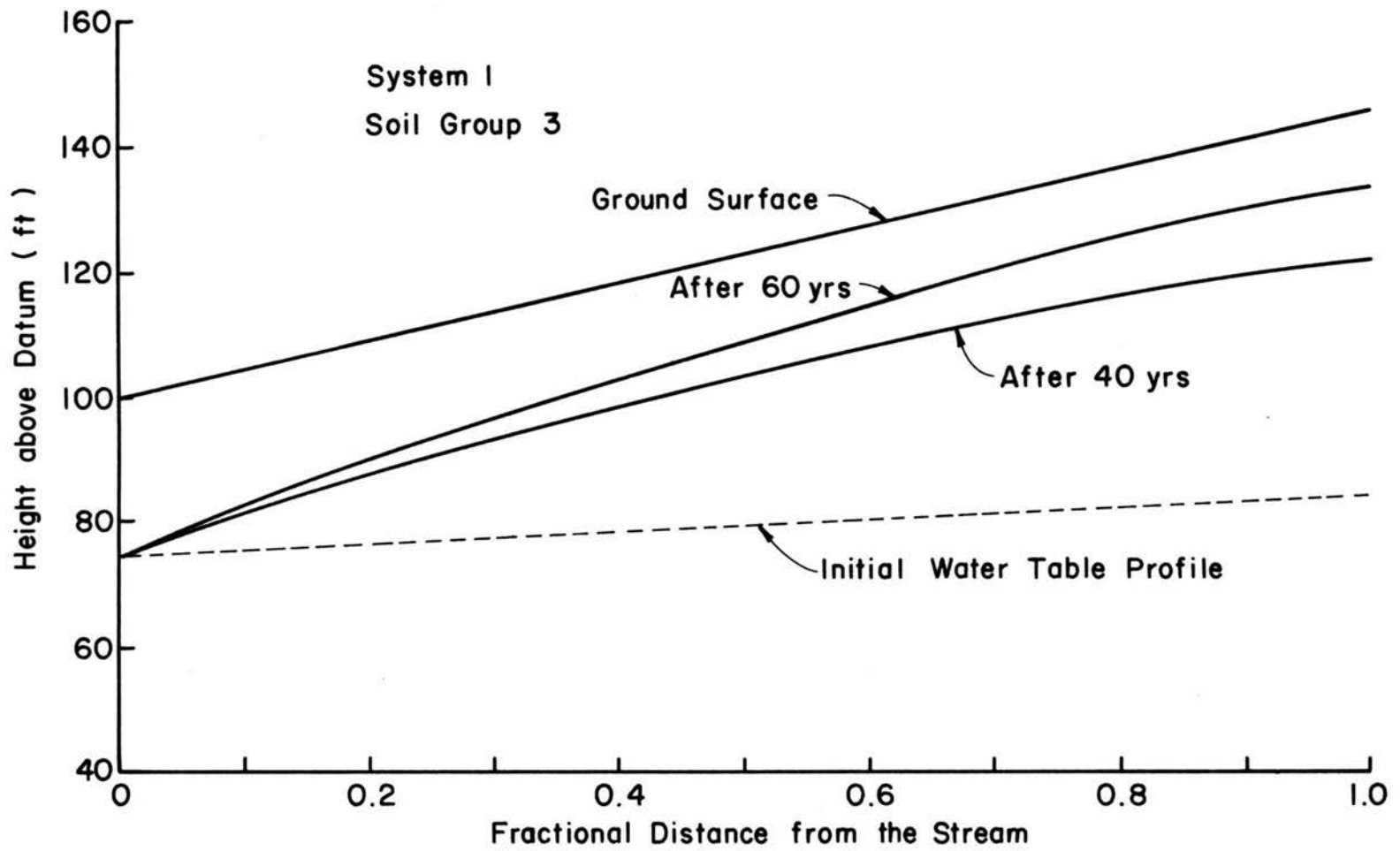

Figure 6.6.3 Water Table Envelope Curves For System 1, Soil Group 3

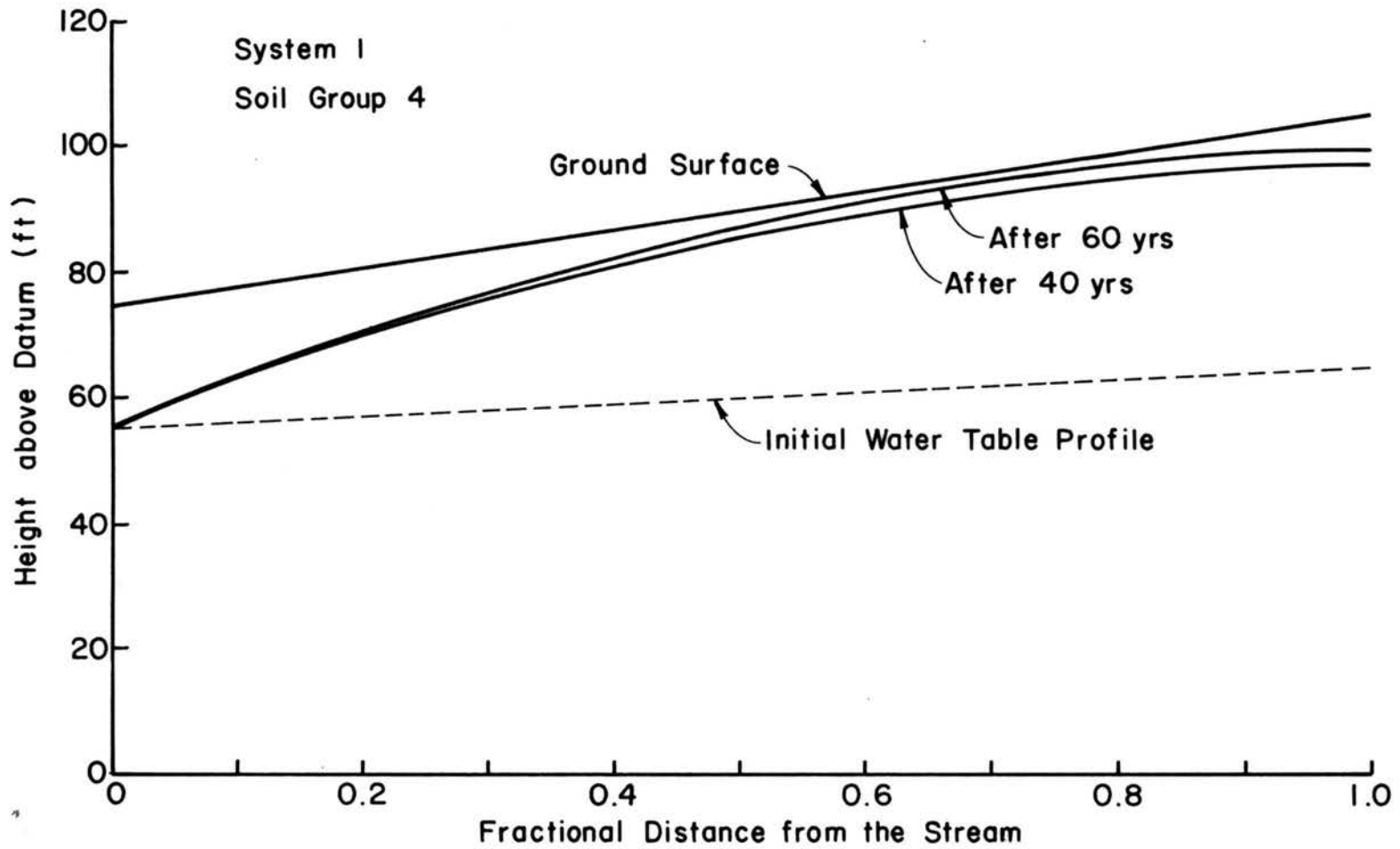

Figure 6.6.4 Water Table Envelope Curves For System 1, Soil Group 4

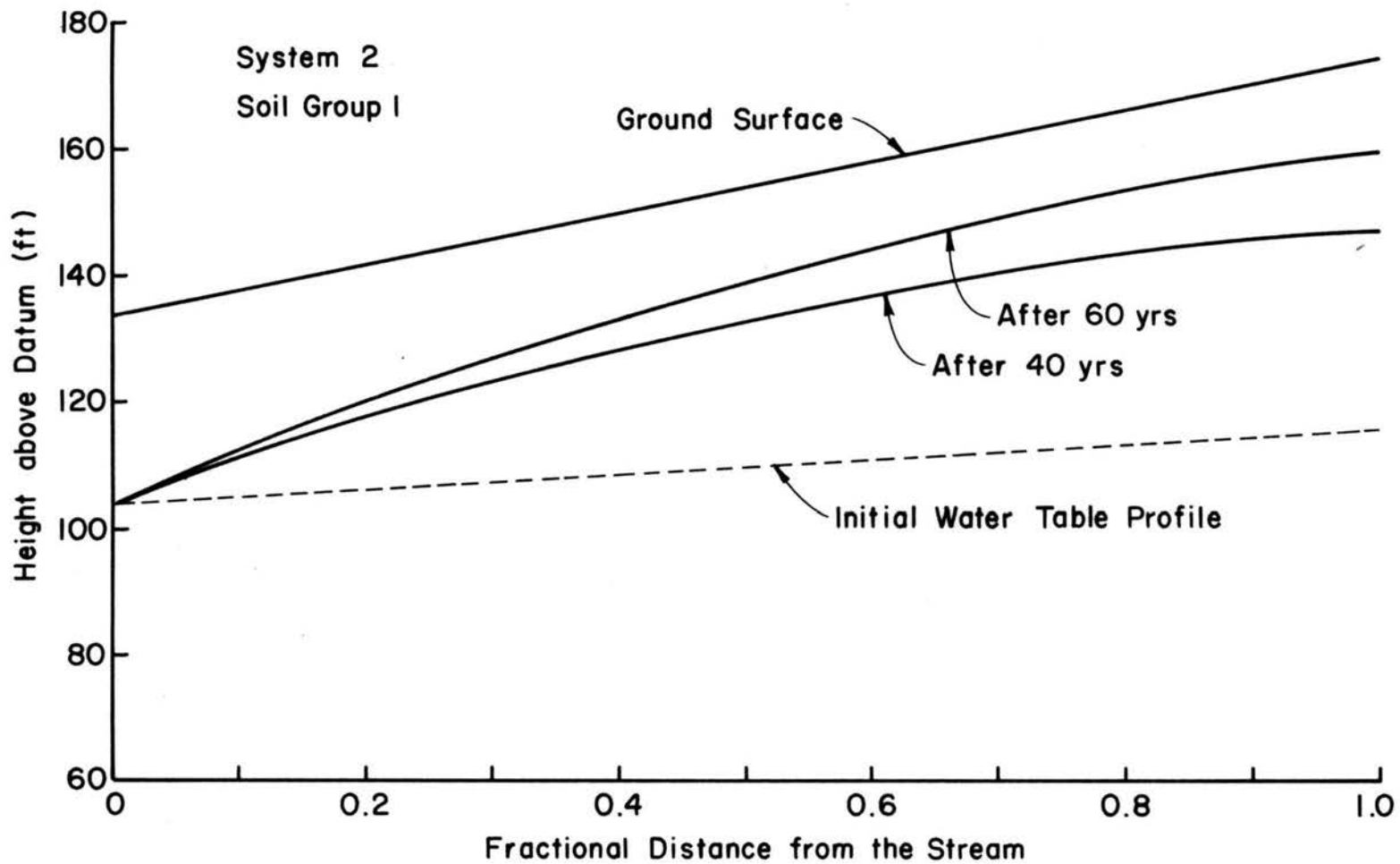

Figure 6.6.5 Water Table Envelope Curves For System 2, Soil Group 1

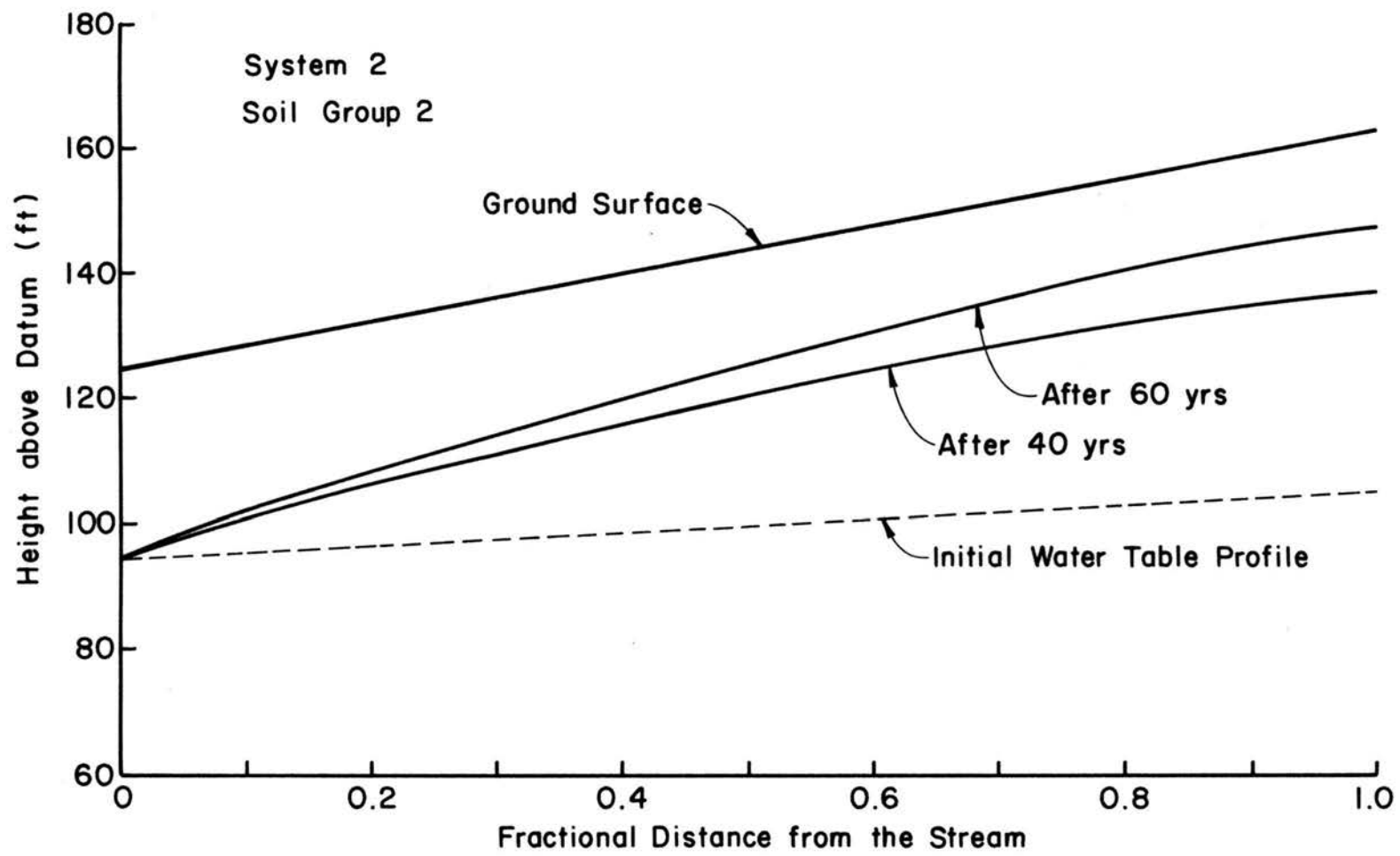

Figure 6.6.6 Water Table Envelope Curves For System 2, Soil Group 2

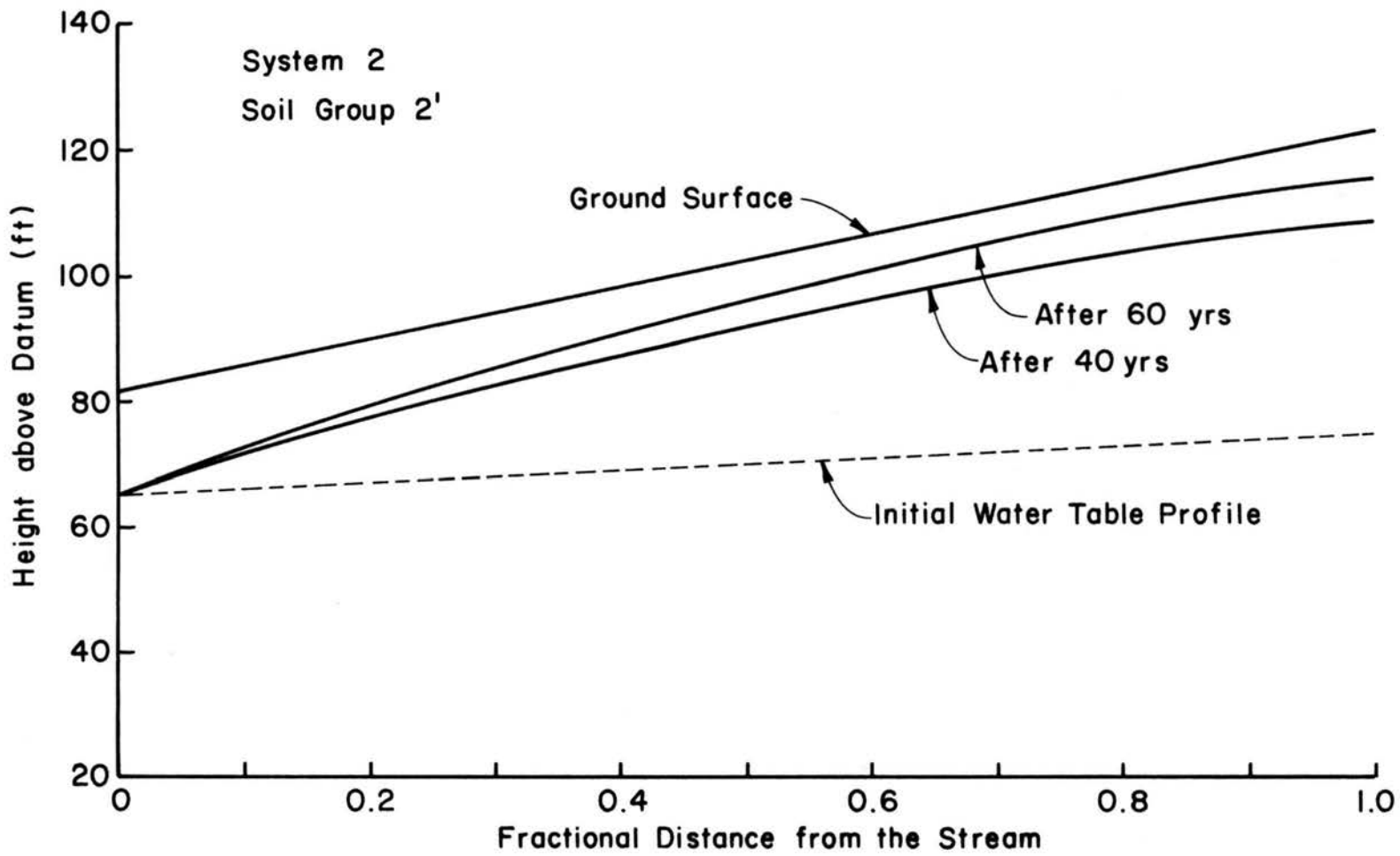

Figure 6.6.7 Water Table Envelope Curves For System 2, Soil Group 2'

6.7 CONCLUSIONS AND RECOMMENDATIONS

The application of the water table analysis to the project indicates that the transients are dominant even after a long time such as 40 to 60 years. The application also shows that in System 1, Soil Group 4, needs drainage arrangements even as early as 40 years. System 2, Soil Group 2', needs drainage arrangements after about 60 years. In the other areas the water table build up is within tolerable limits. A way to reduce the water table build up in System 1, Soil Group 4, and in System 2, Soil Group 2', is by altering the system design. Since a reduction in deep percolation will result in lower requirement efficiency and correspondingly lower yields, there is an optimization problem here. The installation of drainage arrangements should cost less than the income foregone by operating at lower requirement efficiency. This analysis is left for future research.

CHAPTER 7

WATER ISSUE STRATEGIES

7.1 INTRODUCTION

Water issue strategies are important in sizing the conveyance systems and involve considerations of social and legal factors. As has already been mentioned, on-farm supply and the irrigation interval are to vary from irrigation to irrigation. The choice of the interval as was seen depends on the crop and soil water factors, cost of operation, and the climatic factors. When depth requirements were scheduled, one operationally convenient interval was chosen that would be compatible with soil-water requirements. In this module it will be seen how the different possible strategies give rise to different operational features, how they affect the canal capacities and how an optimal strategy might be derived.

7.2 LITERATURE REVIEW

Water issue methods fall under the following categories:

- (i) On-demand,
- (ii) Semi-demand,
- (iii) Canal rotation and free demand,
- (iv) Rotational System and
- (v) Continuous flow.

The details of these definitions and the suitability of any method to any given condition may be found in Sagardoy et.al. (1982). The on-demand system designs require a higher level of flexibility of the distribution system and is

more appropriate for farm systems that give large returns (as in the case of developed countries). Patterns of the demands can be identified and the system can be designed as a rotational system at any given probability level of demand. Since any given canal system can continuously or discontinuously convey water, all the five strategies may be broadly classified into two main categories as follows: (see also El-Kady et.al., 1982)

- 1) Rotational Water Issues (RWI) at a given canal hierarchy. By this we mean that the outlets from the particular canal to a lower order canals (eg. secondary canal to tertiary canals) are open in turn as long as the canal conveys water.
- 2) Continuous Water Issues (CWI) at a given canal hierarchy. By this we mean that the outlets from the particular canal to lower order canals would be open continuously as long as the particular canal conveys water.

Any type of farm water issue strategy must also be socially acceptable to the farmers (De Los Reyes (1979), El-Kady et.al. (1982)). Farmer participation is expected for success in the implementation of the water issues (Thavaraj, (1979)). Canal system operation associated with the farm water issue strategy should be such that the system is easily operated and the corruption is reduced (Sagardoy (1982)).

An important aspect of farm water issue is the acceptability of night irrigation. The effect of this on the canal capacities will be shown subsequently. The studies of Lowdermilk et.al. (1978) in Pakistan indicate that night irrigation is practiced with same acuity as regards inspection and

repair of leaks and spills during irrigation as the day irrigation. This demonstrates the physical possibility and to some extent the acceptability of night irrigation. Even though it is not discussed in the literature, owing to religious beliefs, farmers might not irrigate on religiously important days and at prayer times. These types of inputs are expected for the devising appropriate water issue strategies.

7.3 GENERAL ANALYSIS OF WATER ISSUE STRATEGIES

7.3.1 Possible Combinations

The possible combinations of water issue strategies are given in Table 7.3.1. These combinations could further be expanded to include night and day irrigation rotations. Rotational issues result in reduced canal capacities and for this reason alone are sometimes favored. There is also another reason for why rotational issues are favored. The irrigation delivery system responds relatively slowly and may not respond as desired within the time span of one irrigation to another. For the same reasons, the rotations have to be implemented low in the hierarchy of the system.

7.3.2 Some Basic Rotational Water Issue Strategy Concepts

Consider a system that needs to be irrigated on day, d_1 , and subsequently on day, d_2 . Assuming that the cropping activity is staggered suitably the interval would be $\Delta T = d_2 - d_1$. Considering a (sub) system at any level of the canal hierarchy, let the area under its command be A_c . Let the area irrigated at any given time be A_j . Then,

$$\sum_{j=1}^{\Delta T} f A_j = A_c \quad (7.3.1)$$

TABLE 7.3.1 POSSIBLE COMBINATIONS OF WATER ISSUE STRATEGIES

Case #	Main Canal		Secondary Canal		Tertiary Canal		Turnout Area		REMARKS*
	CWI	RWI	CWI	RWI	CWI	RWI	CWI	RWI	
1	X		X		X		X		Results in large canal capacities and minimal operation.
2	X		X			X	X		Operation is needed more at tertiary canal.
3	X			X	X		X		Operation is needed more at secondary canal.
4	X			X		X	X		Operation is needed both at secondary and tertiary canals.
5		X	X		X		X		Operation is needed at main canal.
6		X	X			X	X		Operation is needed at main and tertiary canal.
7		X		X	X		X		Operation is needed at main and secondary canal.
8		X		X		X	X		Operation is needed at all three levels.
9	X		X		X			X	Results in farmer sharing rotations still relatively large canal capacities.

TABLE 7.3.1 POSSIBLE COMBINATIONS OF WATER ISSUE STRATEGIES

Case #	Main Canal		Secondary Canal		Tertiary Canal		Turnout Area		REMARKS*
	CWI	RWI	CWI	RWI	CWI	RWI	CWI	RWI	
10	X		X			X		X	As in case (2) + farmer sharing.
11	X			X	X			X	As in case (3) + farmer sharing.
12	X			X		X		X	As in case (4) + farmer sharing.
13		X	X		X			X	As in case (5) + farmer sharing.
14		X	X			X		X	As in case (6) + farmer sharing.
15		X		X	X			X	As in case (7) + farmer sharing.
16		X		X		X		X	As in case (8) + farmer sharing. Results in least canal capacities.

* These remarks are under the assumption that the whole farm should be irrigated in relatively short time compared to the irrigation interval.

where $f = 1/2$ if night irrigation is possible and $f = 1$ if night irrigation is not possible. The objective is to minimize $A_j (j \in (1, \Delta T))$ and the solution is (see Cooper and Cooper (1981))

$$A_j = \frac{A_c}{f\Delta T} \quad (7.3.2)$$

which is constant during the interval ΔT .

Thus, in any rotational system the canal sizes would depend on the irrigation interval ΔT . Another important aspect of this strategy is the constant nature of the flow rates carried during the irrigation interval in the hierarchy of the system studied. Once the extent that can be irrigated simultaneously is found, the turns of allocation of water to the sub area concerned may be found using socially acceptable rules. It is hypothesized that one such a rule would be to begin an irrigation with the outlet at the tail end of the canal studied as suggested by (de Los Reyes (1979)).

7.3.3 Some Basic Continuous Water Issue Strategy Concepts

Conveyance system cost for a continuous type delivery system designed to serve at the farm level the particular irrigation requirement for all the farm area simultaneously in any given irrigation will be high. For this reason at the farm level, a continuous supply may be given expecting the farmer to rotatingly irrigate portions of the field in the farm in turn. Thus, any analysis of a continuous water issue strategy should be done at the farm level. This strategy should be included in a project scale design methodology. Again in order to minimize canal capacities, the fractional area, a_f , of a farm of size, A_f must satisfy

$$a_f = \frac{f A_f}{\Delta T} \quad (7.3.3)$$

where f is defined as before.

In general, irrigating portions of the farm within any given half day elongates the application time reducing the flow rate. In surface irrigation systems for good spreading, a minimum flow rate is specified. Thus, the time of application might become shorter and in turn a_f as given by Equation (7.3.3) might have to be adjusted upwards. Correspondingly, it becomes not possible to elongate the irrigation activity for the total length of the irrigation interval.

7.3.4 Rotational vs. Continuous Water Issues

Continuous water issues expecting the farmer to irrigate portions of the farm in chain like sequence, in general, is not a favorable strategy from farmers' viewpoint. Farmers also have to engage in many other personal and agricultural tasks. This might lead them to favor the idea of irrigating the whole of the farm in as short time as possible. From an engineering view point, this involves an optimization problem. Since the time of application can be extended in the case of CWI, the requirement efficiency in general increases and reduces the deep percolation for a given amount of applied water. This might be demonstrated by using the sub-optimal analysis for farm systems with level borders reported in Chapter 5 (Project Scale Farm Design Module). The results of the sub-optimal analysis for the case of farmer irrigating 1 acre and 5 acres of the farm in any irrigation is given in Table 7.3.2 for the case of applied depth .45 feet. In this case the gain in requirement efficiency and the corresponding yield increase should be greater than the incremental cost of providing for increased capacity due to CWI. In Equation (7.3.3) if $f = 1$ (i.e. night irrigation not possible), the issue strategy cannot be called CWI asserting de Los Reyes (1979) view point that the difference between CWI and RWI is not "black and white."

TABLE 7.3.2 COMPARISON OF THE EFFECTS DUE TO CWI AND RWI ON SUB-OPTIMAL DESIGN VALUES FOR LEVEL BORDER SYSTEMS*

Soil Type #	Farmer Irrigating 100% Of The Farm In 12 Hrs.				Farmer Irrigating 20% Of The Farm In 12 Hrs.			
	q (ft ² /S)	T (Minutes)	L (Ft)	E _r	q (ft ² /S)	T (Minutes)	L (Ft)	E _r
1	.00945	71	90	.84	.00189	357	90	.99
2	.00945	87	110	.96	.00189	436	110	1.00
3	.00945	103	130	.88	.00189	516	130	1.00
4	.00945	103	130	.93	.00189	516	130	1.00

* Data and notations as in Module # (Depth of Application = .45 ft.)

The major difficulty in any issue strategy that does not include night irrigation is the wastage of water during night times. If the system manager tries to save water he should do so by reducing the water in the canals. There is a lower limit to which he can save because of transients. If night irrigation is possible under RWI strategy, different farmers get different turns in day and night, but under CWI strategy, the same farmers have to continuously irrigate. Under CWI strategy, farmers are likely to seek outside labor to assist in irrigation. This might favor the RWI system but it might be offset by the fact that RWI increases the necessity for interdependence. Summarily, in trying to adopt a strategy the following studies need be done:

- (i) Farmers choice about adapting to the strategies,
- (ii) system optimality studies about the cost effectiveness of providing the different capacities under different issue strategies and,
- (iii) any possible detrimental effects on the groundwater table stuation.

This is a multi-objective problem and farmers' choice should be given a high priority.

7.3.5 Physical Arrangements At The Terminal Systems

In many systems, the release to the individual farmers from the final level of the canal system is uncontrolled. Since the flow requirements vary over the season, some physical arrangement to reduce the variations in the uncontrolled releases are called for. Some theoretical aspects of this problem are given below.

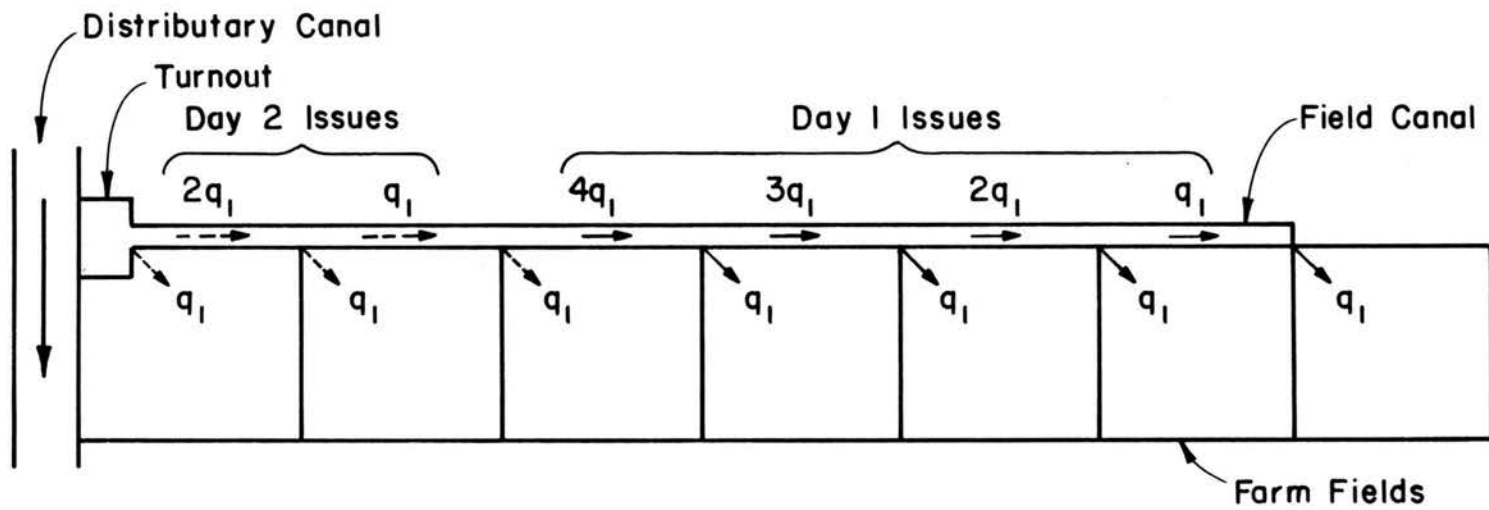

Figure 7.3.1 Layout Plan Of Field Canal System

Suppose within a turnout area a system has to be designed to deliver a flow of amount, q_1 (cfs), to each farm. Both under CWI and patternized RWI, we can relate the field canal flow, Q , just upstream of a field outlet as

$$Q = F(h) \quad (7.3.4)$$

where h is the head of water just upstream of the outlet. The flow q_1 through the outlet may be related as

$$q_1 = f(h) \quad (7.3.5)$$

Choosing the canal cross-sectional parameters and the outlet cross-sectional parameters that $F(h) \approx \mu f(h)$ the flow ratio (q_1/Q) will be approximately equal to μ . Relationships (7.3.4) and (7.3.5) assume that the flow is steady which is a usual one. As an example, the flow, Q , in a trapezoidal canal may be related as (in English units)

$$Q = \frac{1.486}{n} S_o^{1/2} B \left(1 + \frac{Mh}{B}\right) h \left\{ (B+Mh) H / (B+l h) \right\}^{2/3} \quad (7.3.6)$$

where

- B = Bed width of the canal
- M = Side slope of the canal
- S_o = Bed slope of the canal
- n = Manning's Roughness Coefficient
- l = $2\sqrt{M^2 + 1}$ and
- h = Depth of flow

Suppose the flow is delivered through a trapezoidal side weir (uncontrolled) from the canal. Then

$$q_1 = \frac{4 C_d \sqrt{2gh}}{15} (5 bh + 2 m h^2) \quad (7.3.7)$$

where,

- b = Bottom width of the weir
 m = Side slope of the weir
 C_d = Coefficient of discharge and
 g = Acceleration due to gravity.

Equation (7.3.7) may be modified as

$$q_1 = \frac{4C_c b \sqrt{2gh}}{3} \left(1 + 0.4 \frac{m}{b} h \right) h \quad (7.3.8)$$

The flow ratio

$$\begin{aligned}
 q_1/Q &= \alpha h^{-1/6} (b + .4 m h) / [(B + M h)^{5/3} / (B + l h)^{2/3}] \\
 &= (b + .4 m h) / \Psi (h)
 \end{aligned} \quad (7.3.9)$$

where

$$\Psi (h) = [(B + M h)^{5/3} / (B + l h)]^{2/3} (h^{1/6} / \alpha), \quad (7.3.10)$$

and

$$\alpha = 4/3 C_d \sqrt{2g} n / (1.486 \sqrt{S_0}) \quad (7.3.11)$$

The factors b and m may be found by minimizing (Hilderbrand (1956)) the integral,

$$S = \int_{H_1}^{H_2} [\mu - (q_1/Q)]^2 dh \quad (7.3.12)$$

where H_1 and H_2 are the expected lower and upper bounds of the depth of flow in the canal.

Setting

$$\partial S / \partial b = 0 \quad \text{and} \quad \partial S / \partial m = 0,$$

we have,

$$\mu H_1 \int_{H_1}^{H_2} \frac{1 \, dh}{\Psi(h)} - H_1 \int_{H_1}^{H_2} (b + .4 m h) / \Psi^2(h) \, dh = 0 \quad (7.3.13)$$

and

$$\mu H_1 \int_{H_1}^{H_2} \frac{h \, dh}{\Psi(h)} - H_1 \int_{H_1}^{H_2} (b + .4 m h) / \Psi^2(h) \, dh = 0 \quad (7.3.14)$$

Letting

$$A_1 = H_1 \int_{H_1}^{H_2} 1 / \Psi(h) \, dh,$$

$$A_2 = H_1 \int_{H_1}^{H_2} h / \Psi(h) \, dh,$$

$$B_1 = H_1 \int_{H_1}^{H_2} 1 / \Psi^2(h) \, dh,$$

$$B_2 = H_1 \int_{H_1}^{H_2} h / \Psi^2(h) \, dh,$$

(7.3.15)

and for

$$C_2 = H_1 \int_1^{H_2} h^2 / \psi^2(h) dh,$$

$$b = \mu (A_2 B_2 - A_1 C_2) / (B_2^2 - B_1 C_2) \quad (7.3.16)$$

$$m = 2.5 * \mu (A_1 B_2 - A_2 B_1) / (B_2^2 - B_1 C_2) \quad (7.3.17)$$

Equations for b and m may be used to obtain the parameters of the weir. An example of this process of flow dividing is summarized in Table 7.3.3. It is seen that by this process, it is possible to issue the flow from a canal according to a ratio with good accuracy.

7.4 APPLICATION OF PROPORTIONAL DISTRIBUTIONS STRATEGY

In the previous chapter, the factors affecting the choice of a water issue strategy were discussed. For the project the details of which are given in Chapter 5, the following are the choices of farmers:

- (i) Rotational water issued. Total irrigation time of 12 hours of the farm preferred, and
- (ii) irrigation during night time is possible.

Using Equation (7.3.2) at all the different levels of hierarchy of the canal system, the peak requirement flow rates are given in Table 7.4.1 and 7.4.2 using the farm flow rates obtained from the Chapter (Table 5.4.12). This may be repeated for other irrigations in a similar manner.

TABLE 7.3.3
RESULTS OF FLOW DIVISION BY A TRAPEZOIDAL
WEIR FROM A TRAPEZOIDAL CANAL.

Height h (ft)	Flow Through The Weir (cfs)*		Flow in the Canal (cfs)*		Ratio		Error %	
	μ							
μ	.500	.333	.500	.333	.500	.333	.500	.333
.85	1.24	.82	2.47	2.47	.501	.334	.20	.30
.90	1.38	.92	2.75	2.75	.501	.224	.20	.30
.95	1.53	1.02	3.06	3.06	.501	.334	.20	.30
1.00	1.69	1.13	3.38	3.38	.501	.334	.20	.30
1.05	1.86	1.24	3.72	3.72	.501	.334	.20	.30
1.10	2.04	1.36	4.07	4.07	.501	.334	.20	.30
1.15	2.23	1.48	4.45	4.45	.501	.334	.20	.30

*Rounded to two decimal places

Canal Data: $B = 2'$, $S_0 = .004$, $M = 1.5$

Results of Weir Parameters:

- 1) $\mu = 0.33$, $b = 1.15''$ and $m = .20$
- 2) $\mu = .50$, $b = 1.73''$ and $m = .30$

The flow divisions lower in the hierarchy are possible in the same manner. The design flows assume that the farmers will make use of the water issued to them. Farmers for personal reasons such as sickness, etc., might not be able to irrigate on the day they are allocated water. Trading of turns might take place and the overall percentage of farmers not using their turns might be low. In any case, the following uncertainties should in general be accounted for:

- i) Farmers' inability to use water during their turns,
- ii) flow increases to cope with transients,
- iii) surface conveyance losses,
- iv) variations in the roughness parameters of the canal and
- v) cropping pattern changes.

These may be accounted for by a multiplication factor that should be used in increasing the basic design flow values. This factor in the present case is assumed to be .10 (10%).

7.5 CONCLUSIONS AND RECOMMENDATIONS

CWI and RWI strategies were described and the factors affecting the choice of any one of the water issue strategies were described. To minimize canal capacities under a CWI strategy the individual farm needs to be subdivided into blocks that are irrigated in any given duration. In RWI strategy such subdivision is done by dividing a given number of farms and irrigating the whole farm within any given duration. The rotation should be done at the lowest canal hierarchy for minimal canal capacities. Any suitable combination of these two strategies can also be adopted depending on the social acceptability. In both the strategies the effect of the irrigation interval is readily seen.

TABLE 7.4.1
FLOW RELEASES FROM MAIN CANAL - SYSTEM 1

Secondary Canal Number	Peak Flow Requirement (cfs)	Design Flow (cfs)
1	13.77	13.84
2	14.23	14.52
3	18.36	18.55
4	16.98	17.15
5	10.56	10.67
6	14.88	15.03
7	10.80	10.91
8	17.52	17.70
9	13.92	14.06
10	17.76	17.94
11	14.10	14.24
12	9.80	9.90
13	10.52	10.63
14	14.58	14.73
15	15.30	15.45
16	14.34	14.48
17	16.75	16.92
18	13.548	13.77
19	8.70	8.88
20	13.05	13.32

TABLE 7.4.2
FLOW RELEASES FROM MAIN CANAL - SYSTEM 2

Secondary Canal Number	Peak Flow Requirement (cfs)	Design Flow (cfs)
1	11.48	11.60
2	14.23	14.37
3	13.31	13.44
4	11.52	11.64
5	15.12	15.27
6	12.48	12.61
7	14.64	14.79
8	11.04	11.15
9	14.88	15.03
10	11.52	11.64
11	15.36	15.52
12	10.79	10.90
13	14.23	14.37
14	9.41	9.51
15	8.262	9.35

It was also seen for the given project (See Chapter 5) under RWI strategy, farmers might improve performance as far as the requirement efficiency is concerned and this results in lower deep percolation as well. The possibility of designing an uncontrolled issue system at the terminal level to issue water proportionate to the upstream head was also demonstrated. This means that by adopting such designs, it is possible to have only one measuring device at the turnout to issue the desired turnout flow. It is recommended this study is extended accounting for the head loss occurring past such devices (Gates et. al., 1983). For the project studied the secondary canal flow releases during peak requirement are given for the case of farmers preferring RWI.

CHAPTER 8

HYDRAULIC SIMULATION MODULE

8.1 INTRODUCTION

Hydraulic transients in the canal systems of an irrigation project require study for two main reasons:

- (i) To study the canal hydraulic parameters that result in quickest possible response to the water flow needs at required locations and,
- (ii) to study the operational features of the various components of the system so that a plan for management can be developed.

The operations should result in saving of the water and in meeting the farmers' requirements in a timely manner. The study of hydraulic transients is done preferably by a simulation approach since the identification of response parameters for the whole system is complex. In order to study the hydraulic transients in the canal system, basically a model is needed to study the flow conditions resulting from a step change in the upstream flow release in a prismatic canal subject to different kinds of downstream release conditions.

The objective of this module is:

- (i) To develop a model that will enable us to formulate the maximum response problem in the conveyance system, and;
- (ii) to use the model to find out different response times so that operational schedules are developed.

8.2 LITERATURE REVIEW

The advances in the study of unsteady open channel flow have resulted in many different numerical schemes for many different cases of unsteady open channel flow. Flood and tidal flows in river systems, dam break problems, power canal surges, surface run-off problems in watersheds and irrigation fields, and storm drainage problems are the more commonly studied cases of unsteady open channel flow. Though, all these problems might have common features, irrigation canal flow problems have added features of point wise lateral releases and downstream control, often temporal. In flood flow problems the emphasis is on the attenuation of flood peaks along the known stream reaches which are often uncontrolled or have some natural controls like free fall or submergence into a relatively a larger body of water. The main types of unsteady flow modeling are the implicit and explicit finite difference schemes applied to the momentum and continuity equations (Mahmood and Yevjevich, (1975), Ponce (1980), Abbott (1979), BHRA (1976), and Cunge and Holly (1981)). The implicit schemes require greater computational efforts. For the numerical implementation of explicit schemes good discretization should be chosen to satisfy stability conditions. In irrigation canal system design, to study design alternatives and to develop operation and management criteria, we require an efficient numerical scheme.

Methods noted for their relative accuracy and ease of computations are the Variable Parameter Muskingum Cunge (VPMC) Method, (Price (1978), Ponce and Yevjevich (1978)) and the Variable Parameter Diffusion (VPD) Method, (National Environment Research Council (NERC), Flood Studies Report (FSR), (1975), Price (1978)). The VPMC is relatively easier to compute with a finite difference scheme. An important aspect of the Muskingum routing equations (Ponce, (1978), Ponce (1979)) is that they use relatively large

time and space steps. In the simplified Muskingum Method (Ponce (1979)) both steps are of the order $(1/S_0)$, where S_0 is the bed slope. Ponce (1979) suggests average values of discharge and celerity to be used for the determination of the Muskingum parameters. Another relatively easier flow routing model is the Multiple Linearization (ML) Method of Keefer and McQuivey (1974). This method generates response functions at different reference discharges and sums up the responses due to the discretized inputs. The advantage of a linearized diffusive (or Zero-Inertia) scheme is that it lends itself to closed form solutions which might be used in a discretized form. As has already been mentioned, we need to parameterize the factors that influence water advance in the canals. Irrigation canal slopes are very mild in general and a diffusive scheme will be a closer approximation to the full dynamic equation. Thus, the diffusive or zero-inertia formulation will be adopted.

8.3 AN INTEGRAL METHOD WITH A DIFFUSIVE SCHEME FOR WATER ADVANCE IN IRRIGATION CANALS

8.3.1 Basic Equations

In a canal that conveys an amount Q (Vol/Time) and having a cross-sectional area A , the mass continuity is given by (Sritharan (1982b)):

$$\frac{\partial Q}{\partial x} + \frac{\partial A}{\partial t} + q_l = 0 \quad (8.3.1)$$

where x is the length along a canal from a reference point, t the time and q_l the lateral outflow per unit length of the canal. If the lateral outflows have pointwise distributions then q_l could be given as

$$q_l = \sum q_{li} \delta(x-x_i) \quad (8.3.2)$$

where, q_{li} is the strength of the sink acting at x_i . The zero-inertia momentum equation is given by

$$\frac{\partial y}{\partial x} = S_o - S_f \quad (8.3.3)$$

where y is the depth of flow, S_o , the bed slope and S_f , the friction slope. Using Manning's equation, S_f may be given as

$$S_f = C^2 n^2 Q^2 / A^2 R^{4/3} \quad (8.3.4)$$

where R is the hydraulic radius, n the Manning's roughness and C a unit conversion factor.

Setting $A = f(y)$ and $A^2 R^{4/3} = \phi(y)$, Equations (3.1) and (3.3) could be combined for the case of $q_b = 0$ as

$$\frac{\partial^2 Q}{\partial x^2} - D_1 \frac{\partial Q}{\partial x} = D_2 \frac{\partial Q}{\partial t} \quad (8.3.5)$$

where

$$D_1 = \phi^1(y) C^2 n^2 Q^2 / \phi^2(y) + (f''(y)/f'(y)) (S_o - C^2 n^2 Q^2 / \phi(y)) \quad (8.3.6)$$

$$D_2 = 2 C^2 n^2 Q f'(y) / \phi(y) \quad (8.3.7)$$

8.3.2 A Linearization Scheme

We have, in general,

$$\left. \begin{array}{l} Q = Q(x,t) \\ y = y(x,t) \end{array} \right\} \text{for} \left\{ \begin{array}{l} x \in [0, x_a(t)] \\ t \in [0, t] \end{array} \right\} \quad (8.3.8)$$

where $x_a(t)$ is the advanced length at time t .

Thus, we have,

$$D_1 = D_1(Q(x,t), y(x,t), S_o) \quad \text{and}$$

$$D_2 = D_2(Q(x,t), y(x,t), S_o)$$

Define

$$\bar{Q}(t) = \left(\int_0^{x_a(t)} Q(x, t) dx \right) / x_a(t) \quad (8.3.9)$$

and

$$\bar{y}(t) = f^{-1}(\bar{A}(t)) \quad (8.3.10)$$

where

$$\bar{A}(t) = \left(\int_0^{x_a(t)} A(x, t) dx \right) / x_a(t) \quad (8.3.11)$$

consider the domain $x \in [0, x_a(t)]$ and $t \in [t, t + \delta t]$, where δt is $O(1)$, a linearization for D_1 and D_2 is as follows:

$$\bar{D}_2 = D_1(\bar{a}(x, t), \bar{y}(x, t), S_0) \quad (8.3.12)$$

$$\bar{D}_2 = D_2(\bar{Q}(x, t), \bar{y}(x, t), S_0) \quad (8.3.13)$$

In cases of relatively small shifts in the flow normal depth and flow values may be used in the above with Q denoting the incremental flow.

Now, equation (8.3.5) with the linearized terms \bar{D}_1 and \bar{D}_2 can be written as

$$\frac{\partial^2 Q}{\partial x^2} - \bar{D}_1 \frac{\partial Q}{\partial x} = \bar{D}_2 \frac{\partial Q}{\partial t} \quad (8.3.14)$$

for $x \in [0, x_a(t)]$ and $t \in [t, t + \delta t]$. The feasibility of such linearization for the case of trapezoidal canals may be seen from the following.

Consider a trapezoidal canal of bed width, B , and side slopes, m , now

$$D_1 = \frac{1}{B} \left[(10/3) \left\{ \frac{1 + 2m (y/B)}{(1 + m (y/B)) (y/B)} \right\} - \frac{4}{3} \frac{\ell}{(1 + \ell y/B)} \right] S_f$$

$$+ \left\{ \frac{2m}{1 + 2m (y/B)} \right\} \frac{(S_0 - S_f)}{B} \quad (8.3.15)$$

where

$$\ell = 2 \sqrt{m^2 + 1},$$

$$D_2 = 2 (1 + 2m (y/B)) B S_f / Q \quad (8.3.16)$$

S_0 is very small for irrigation canals and $|(S_0 - S_f)|$ reflects the water surface slope. Katopodes and Schamber (1983) have studied the kinematic wave assumption and have found out that for dam break problems in a short interval of time the water surface slopes become nearly horizontal, i.e., $|(S_0 - S_f)|$ is small. Dressler (1952) also found out that the resistance causes more effect on velocity than on the height. As was mentioned in the literature review, for many methods, large time and space steps and the average Q values between the nodes produced satisfactory results. Many non-linear equations in fluid dynamics are linearized in this fashion (Ames (1972), Shetz (1966)).

8.3.3 Transformed Equations

The linearized equations (8.3.14) is of the Fokker-Planck type equation (Stakgold (1967)). This may be transformed by substitution

$$Q = qe^{\alpha x + \beta t} \quad (8.3.17)$$

where

$$\alpha = \bar{D}_1 / 2 \quad (8.3.18)$$

and

$$\beta = - \bar{D}_1^2 / 4 \bar{D}_2, \quad (8.3.19)$$

to

$$\frac{\partial^2 q}{\partial x^2} = \bar{D}_2 \frac{\partial q}{\partial t} \quad (8.3.20)$$

8.3.4 The Advance Problem and the Analogy to Stefan Problem

When water advances over an initially dry bed, or still water (or even over a steady state of flow), the flow (or incremental flow) equations are valid only over the domain $0 \leq x \leq x_a(t)$. Beyond $x_a(t)$ there is no flow (or incremental flow). The analogy of this problem to that of the Stefan Problem (Rubinstein (1971)) is readily seen. Analytical solutions of the Stefan Problems involve finding solutions to transcendental equations (Rubinstein (1971)). This difficulty may be overcome by the integral method (Özisik (1980)).

8.3.5 Integral Method Solution For The Advance Problem

The advance problem with the transformed equation is:

Find $x_a = x_a(t)$, S.t

$$\frac{\partial^2 q}{\partial x^2} = \bar{D}_2 \frac{\partial q}{\partial t} \quad \text{in } 0 \leq x \leq x_a(t) \quad (8.3.21)$$

with the boundary conditions

$$\begin{aligned} \text{(i)} \quad & \text{at} \quad x = 0, \quad Q = Q_0 \\ & \text{i.e. at} \quad x = 0, \quad q = q_0 \\ & \quad \quad \quad q_0 = Q_0 e^{-\beta t} \end{aligned} \quad (8.3.22)$$

$$\begin{aligned} \text{(ii)} \quad & \text{at} \quad x = x_a(t), \quad Q = 0 \\ & \text{i.e.} \quad q = 0 \end{aligned} \quad (8.3.23)$$

Let us assume the following form of q

$$q = q_0 \left(1 + \sum_{i=1}^n a_i \xi^i \right) \quad (8.3.24)$$

where a_i are constants and $\xi = x/x_a(t)$

Before determining the coefficients a_i let us see the general solution for the advance problem using the integral method. On integrating equation (8.3.21) w.r.t. x , we have,

$$\left(\frac{\partial q}{\partial x} \right)_{x=x_a} - \left(\frac{\partial q}{\partial x} \right)_{x=0} = \bar{D}_2 \left[\frac{d}{dt} \int_0^{x_a} q dx - (q)_{x=x_a} \frac{dx_a}{dt} \right] \quad (8.3.25)$$

From equation (8.3.24)

$$\frac{\partial q}{\partial x} = \frac{q_0}{x_a} \left(\sum_{i=1}^n i a_i \xi^{i-1} \right), \quad (8.3.26)$$

and

$$\int_0^{x_a} q dx = q_0 \left(1 + \sum_{i=1}^n \frac{a_i}{(i+1)} \right) x_a \quad (8.3.27)$$

Using equation 8.3.26 and 8.3.27 in 8.3.25 we have

$$\frac{q_0}{x_a} \left(\sum_{i=1}^n i a_i \right) = \bar{D}_2 \left(\frac{d}{dt} q_0 \left(1 + \sum_{i=1}^n \frac{a_i}{(i+1)} \right) x_a \right) \quad (8.3.28)$$

Let

$$\lambda_1 = \sum_{i=1}^n i a_i \quad \text{and}$$

$$\lambda_2 = 1 + \sum_{i=1}^n \frac{a_i}{(i+1)}$$

Using these in equation (8.3.28), we have,

$$\lambda_1 \frac{q_0}{x_a} = \bar{D}_2 \frac{d}{dt} (q_0 \lambda_2 x_a) \quad (8.3.29)$$

Since

$$q_0 = Q_0 e^{-\beta t},$$

$$\frac{dq_0}{dt} = -\beta q_0, \quad (8.3.30)$$

Equation 8.3.29 gives for constants λ_1 and λ_2 ,

$$\frac{\lambda_1 q_0}{x_a} = \bar{D}_2 \left((q_0 \lambda_2) \frac{dx_a}{dt} - \beta x_a q_0 \right) \quad (8.3.31)$$

On integrating equation 8.3.31, we have for the rate of advance,

$$\frac{dx_a}{dt} = \left(\frac{|\lambda_1|}{\lambda_2} \right) (\exp(-\bar{D}_1^2 t / 2 \bar{D}_2)) / \bar{D}_2 x_a \quad (8.3.32)$$

The boundary conditions on Q may be used to evaluate coefficients a_i and subsequently λ_1 and λ_2 . We have the following boundary conditions:

- (i) $Q = 0$ at $x = x_a \Rightarrow q = 0$ at $x = x_a$,
- (ii) $Q = Q_0$ at $x = 0 \Rightarrow q = q_0 = Q_0 e^{-\beta t}$ at $x = 0$,

The following boundary conditions may be assumed:

$$(iii) \quad \partial Q / \partial x = 0 \text{ at } x = x_a \Rightarrow \partial q / \partial x = 0 \text{ at } x = x_a$$

$$(iv) \quad \partial^2 Q / \partial x^2 = 0 \text{ at } x = 0 \Rightarrow \partial^2 q / \partial x^2 \rightarrow 0 \text{ at } x = 0$$

For these conditions it may be shown that $a_1 = -s/2$, $a_2 = 0$ and $a_3 = 1/2$

Subsequently, $(\lambda_1 / \lambda_2) = 4$. The assumption (iii) is on the basis that a smooth transition of Q distribution in the x direction is expected. The assumption (iv) implies that the rate of change of area does not change in the x direction around the point $x = 0$. For more accurate results the assumption (iv) may be substituted by collocation. That is

$$2a_2 / S^2 = \bar{D}_2 \partial q_0 / \partial t = -\bar{D}_2 \beta q_0, \quad (8.3.33)$$

where $S = x_a(t)$

From which we can obtain, for a third degree polynomial fit,

$$\left. \begin{aligned} a_1 &= -(6 + \alpha_0 q_0 S^2) / 4 \\ a_2 &= \alpha_0 q_0 S^2 / 2 \\ a_3 &= (2 - \alpha_0 q_0 S^2) / 4 \end{aligned} \right\} \quad (8.3.34)$$

where $\alpha_0 = -\bar{D}_2 \beta$

Using these in the integral relationship, we have,

$$-\frac{q_0 a_1}{S} = \overline{D}_2 \frac{d}{dt} \int_0^{x_a} q dx \quad (8.3.35)$$

$$\int_0^{x_a} q dx = \int_0^1 x_a q_0 \left(\sum_{i=0}^3 a_i \xi^i \right) d\xi \quad (8.3.36)$$

On using the a_i from 8.3.34 we have

$$\int_0^{x_a} q dx = q_0 x_a (18 - \alpha_0 q_0 x_a^2) / 48 \quad (8.3.37)$$

Thus, we obtain

$$q_0 (6 + \alpha_0 q_0 x_a^2) = \frac{\overline{D}_2 x_a}{12} \frac{d}{dt} \{ q_0 x_a (18 - \alpha_0 q_0 x_a^2) \} \quad (8.3.38)$$

This results in the differential equation

$$\frac{du}{dt} = 36 \frac{(4 - \alpha_0 u) + 4 \alpha_0 u (6 + \alpha_0 u) Q_0 e^{-\beta t}}{(18 - 3 \alpha_0 Q_0 e^{-\beta t} u)} \quad (8.3.39)$$

Where

$$u = x_a^2$$

Now the equation 8.3.39 may be solved by a numerical method such as the Runge-Kutta Method.

8.3.6 Comparison of Results With Exact Solution

The solution of Equation 8.3.20,

$$\partial^2 q / \partial x^2 = \overline{D}_2 \partial q / \partial t \quad \text{for } x \geq 0$$

with,

$$q(0, t) = Q_0 e^{-\beta t},$$

$$q(t, 0) = 0,$$

may be shown to be (Özisk (1980)) as follows:

$$q(x,t) = \frac{x}{\sqrt{(4\pi | \bar{D}_2)}} Q_0 \int_0^t \frac{1}{(t-\tau)^{3/2}} \exp\left(-\beta t + \frac{x^2 \bar{D}_2}{4(t-\tau)}\right) dt \quad (8.3.33)$$

The integral of equation 8.3.33 can be shown to be (Özisk (1980)) as follows:

$$q(x,t) = \frac{2}{\sqrt{\pi}} Q_0 \int_{x/\sqrt{4\alpha t}}^{\infty} e^{-\eta^2} e^{-\beta\left(t - \frac{x^2}{4\alpha\eta^2}\right)} d\eta \quad (8.3.34)$$

where $\alpha = 1/\bar{D}_2$

i.e.,

$$q(x,t) = \frac{2 e^{-\beta t}}{\sqrt{\pi}} Q_0 \int_{x/\sqrt{4\alpha t}}^{\infty} e^{-\eta^2 + \frac{\beta x^2}{4\alpha\eta^2}} d\eta \quad (8.3.35)$$

The above integral can be shown to be (Abramowitz and Stegun (1965))

$$= \frac{\sqrt{\pi}}{4} \left[e^{2\beta_0} \operatorname{erfc}\left(\frac{x}{\sqrt{4\alpha t}} - \beta_0 \frac{\sqrt{4\alpha t}}{x}\right) + e^{-2\beta_0} \operatorname{erfc}\left(\frac{x}{\sqrt{4\alpha t}} + \beta_0 \frac{\sqrt{4\alpha t}}{x}\right) \right] \quad (8.3.36)$$

where

$$\beta_0 = \bar{D}_1 x/4$$

Using equation 8.3.36 in 8.3.35, we have

$$q(x,t) = \frac{e^{(\bar{D}_1^2 t/4\bar{D}_2)}}{2} Q_0 \left[e^{\bar{D}_1 x/2} \operatorname{erfc} \left(\frac{x}{\sqrt{4\alpha t}} + \frac{\bar{D}_1}{4} \sqrt{4\alpha t} \right) + e^{-\bar{D}_1 x/2} \operatorname{erfc} \left(\frac{x}{\sqrt{4\alpha t}} - \frac{\bar{D}_1}{4} \sqrt{4\alpha t} \right) \right] \quad (8.3.37)$$

i.e.,

$$\frac{q(x,t)}{Q_0} = \frac{e^{\bar{D}_1^2 t/4\bar{D}_2}}{2} \left[e^{\bar{D}_1 x/2} \operatorname{erfc} \left(\frac{x}{\sqrt{4\alpha t}} + \frac{\bar{D}_1}{4} \sqrt{4\alpha t} \right) + e^{-\bar{D}_1 x/2} \operatorname{erfc} \left(\frac{x}{\sqrt{4\alpha t}} - \frac{\bar{D}_1}{4} \sqrt{4\alpha t} \right) \right] \quad (8.3.38)$$

i.e.,

$$\frac{Q(x,t)}{Q_0} = \frac{e^{\bar{D}_1 x/2}}{2} \left[e^{\bar{D}_1 x/2} \operatorname{erfc} \left(\frac{x}{\sqrt{4\alpha t}} + \frac{\bar{D}_1}{4} \sqrt{4\alpha t} \right) + e^{-\bar{D}_1 x/2} \operatorname{erfc} \left(\frac{x}{\sqrt{4\alpha t}} - \frac{\bar{D}_1}{4} \sqrt{4\alpha t} \right) \right]$$

8.3.7 Sample Case

Let us consider a channel of width $B = 20'$, side slope $m = 0.0$, bed slope $S_0 = .0004$, steady state flow depth, $y = 4.0$ ft., with a flow of 213 cfs. For this case with Manning's roughness, $n = .0225$, on linearizing at the steady flow values, we have,

$$\bar{D}_1 = 2.95 \times 10^{-4} \quad \text{and}$$

$$\bar{D}_2 = 7.52 \times 10^{-5}$$

The results of integral method solutions and analytical solution for this case are given in Figure 8.3.1. The closeness of the results are apparent.

An important aspect of this formulation is that the flow resulting from sudden step releases through a downstream control point can be simulated upstream with the same formulae.

8.3.8 Rate of Initial Advance vs Rate of Flow Increase

In trying to study the effect of conveyance system parameters on flow response we could either study the rate of advance of flow layer as given by Equation 8.3.32 or the rate of flow build up given by

$$\frac{\partial Q}{\partial t} = \frac{Q_0}{\sqrt{\pi t}} \left[\left(\frac{\bar{D}_1}{4} \sqrt{4at} - \frac{x}{\sqrt{4at}} \right) e^{\bar{D}_1 x - \left(\frac{x}{\sqrt{4at}} + \frac{\bar{D}_1}{4} \sqrt{4at} \right)^2} - \left(\frac{\bar{D}_1}{4} \sqrt{4at} + \frac{x}{\sqrt{4at}} \right) e^{-\left(\frac{x}{\sqrt{4at}} - \frac{\bar{D}_1}{4} \sqrt{4at} \right)^2} \right] \quad (8.3.39)$$

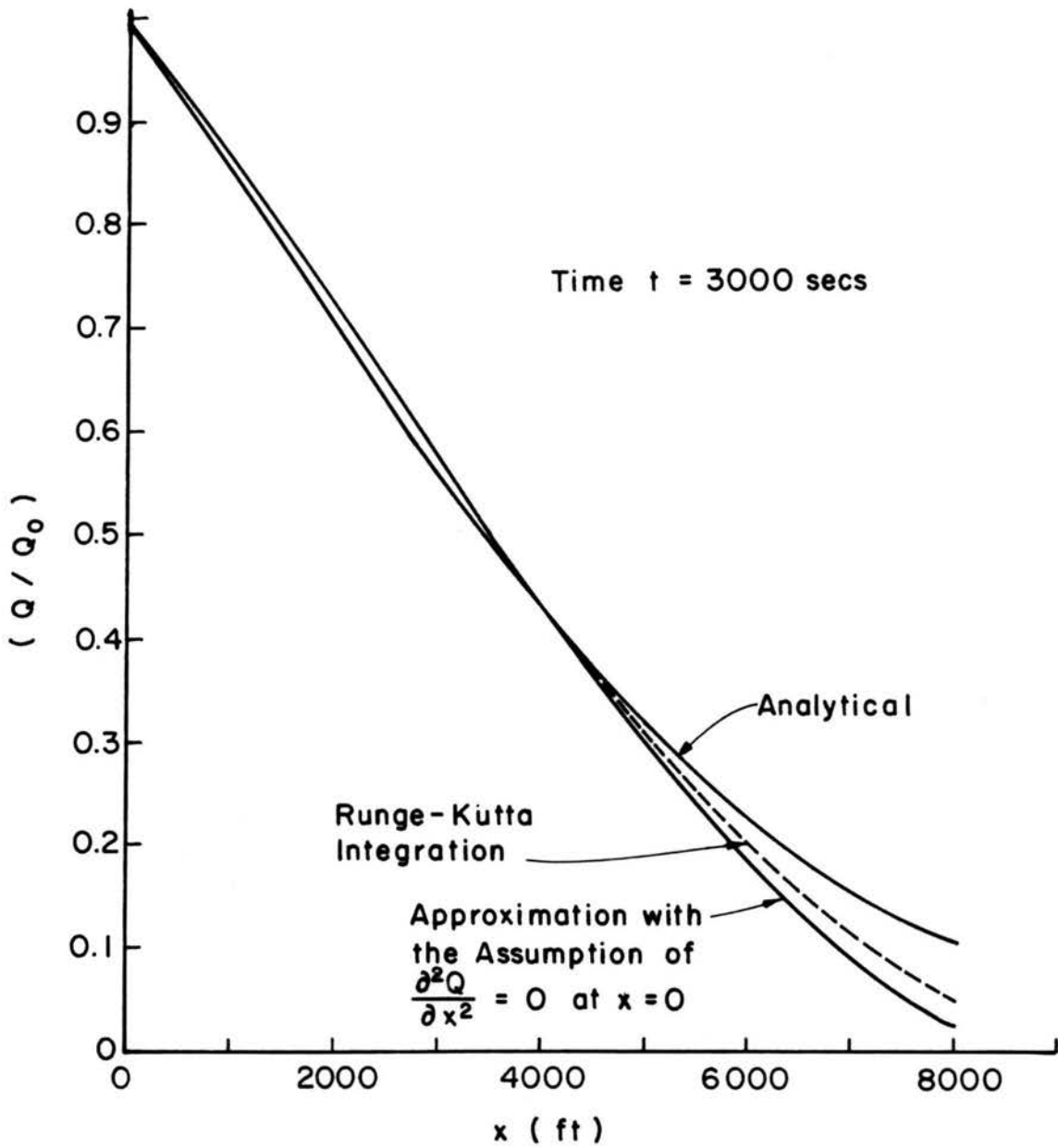

Figure 8.3.1 Comparison Of Integral Method Solutions With Analytical Solution (Q/Q_0 vs Distance)

It is worthwhile to compare these two rates for the sample problem given previously. Figure 8.3.2 shows the result of this study suggesting that either function could be used and the simpler nature of Equation 8.3.32 leads to the choice of rate of advance functions for the study of optimal response of the system.

8.3.9 System Response Times

In studying response times on a macro scale, we might take the systems below the secondary canal systems uncontrolled at their terminal point and the main canal system controlled. In such a formulation, for systems below the secondary systems, we might try to find the time taken to receive at desired locations a high percentage of incremental flow reaches the desired locations. In the main canal, however, we might assume that the flows are regulated at each take off point as is the general practice.

Suppose in a reach of length, L , of a main canal we had at either end controls. In order to release a certain incremental flow downstream, corresponding to an upstream stepped flow release, a certain time delay is expected. This time may be found using the integral method formulation. Operationally speaking, it needs to be checked whether the simultaneous opening of regulators suiting the increased flow requirements would give quicker response than delaying the downstream releases and allowing a build up of head by suitable amounts to effect required flow steps downstream. In some systems such downstream stepping up may not be possible.

8.3.10 General Formulae For Controlled Releases In Canals Of Finite Length

It may be shown that (Özsisik (1980)) for an upstream release function of q given by $f_1(t)$ and downstream release of q given by $f_2(t)$, the system

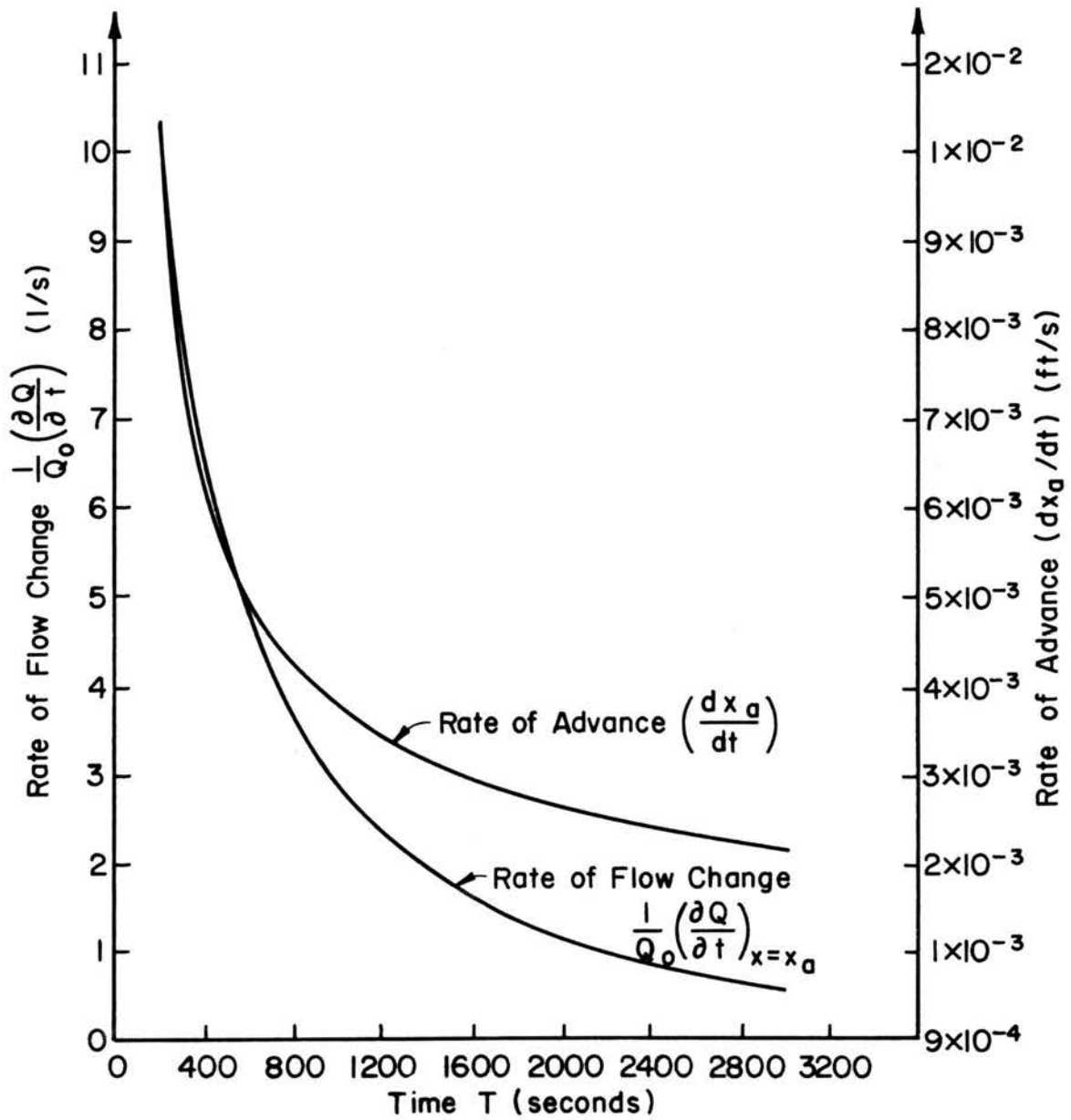

Figure 8.3.2 Comparison Of Advance Rate And Rate Of Flow Change

response function $q(x,t)$ is given by

$$\begin{aligned}
 q(x,t) = & \frac{2}{L} f_1(t) \sum_{i=1}^{\infty} \mu_i - f_2(t) \frac{2}{L} \sum_{i=1}^{\infty} (-1)^i \mu_i \\
 & - \frac{2}{L} \sum_{i=1}^{\infty} \mu_i \left[f_1(0) e^{-\rho_i t} + \int_0^t e^{-\rho_i(t-\tau)} df_1(\tau) \right] \\
 & + \frac{2}{L} \sum_{i=1}^{\infty} (-1)^i \mu_i \left[f_2(0) e^{-\rho_i t} + \int_0^t e^{-\rho_i(t-\tau)} df_2(\tau) \right] \quad (8.3.40)
 \end{aligned}$$

where

$$\mu_i = \left(\frac{L}{i\pi} \right) \sin \left(\frac{i\pi x}{L} \right) \quad \text{and}$$

$$\rho_i = \frac{1}{D_2} \frac{i^2 \pi^2}{L^2} \quad (8.3.41)$$

Since

$$f_1(t) = Q_U(t) e^{-\beta t} \quad \text{and}$$

$$f_2(t) = Q_D(t) c e^{-\beta t},$$

where

$$c = e^{D_1 L/2},$$

we have for $Q(x,t)$

$$\begin{aligned}
 Q(x,t) = e^{\bar{D}_1 x/2} & \left\{ \frac{2}{L} Q_u(t) e^{-\beta t} \sum_{i=1}^{\infty} \mu_i - \frac{2}{L} \left(Q_d(t) e^{-\beta t} \right. \right. \\
 & \left. \sum_{i=1}^{\infty} (-1)^i \mu_i \right) - \frac{2}{L} \sum_{i=1}^{\infty} \mu_i \left[Q_u(0) e^{-\rho_i(t-\tau)} (Q_u^1(t) e^{-\beta t} \right. \\
 & \left. - \beta Q_u(t) e^{-\beta t}) dt \right] + \frac{2}{L} \sum_{i=1}^{\infty} (-1)^i \mu_i \left[c Q_d(0) e^{-\rho_i t} + \int_0^t e^{-\rho_i(\tau-t)} \right. \\
 & \left. (c Q_d^1(t) e^{-\beta t} - c \beta Q_d(t) e^{-\beta t}) dt \right] \left. \right\} \quad (8.3.42)
 \end{aligned}$$

(primes indicate temporal derivatives)

The area relationship $A(x,t)$ might be obtained using the continuity equation

i.e.,

$$A(x,t) = - \int_0^t \partial Q / \partial x dt \quad (8.3.43)$$

From (8.3.42) we have,

$$\begin{aligned}
 \frac{\partial Q}{\partial x} &= \frac{2}{L} Q_u(t) e^{-\beta t} \sum_{i=1}^{\infty} \left(\frac{\bar{D}_1}{2} \mu_i + \mu_i^1 \right) e^{\bar{D}_1 x/2} \\
 &- \frac{2}{L} Q_d(t) e^{-\beta t} \sum_{i=1}^{\infty} (-1)^i \left(\frac{\bar{D}_1}{2} \mu_i + \mu_i^1 \right) e^{\bar{D}_1 x/2} \\
 &- \frac{2}{L} \sum_{i=1}^{\infty} \left(\frac{\bar{D}_1}{2} \mu_i + \mu_i^1 \right) e^{\bar{D}_1 x/2} I_i \\
 &+ \frac{2}{L} \sum_{i=1}^{\infty} (-1)^i \left(\frac{\bar{D}_1}{2} \mu_i + \mu_i^1 \right) e^{\bar{D}_1 x/2} J_i \quad (8.3.44)
 \end{aligned}$$

where

$$\mu_i^{-1} = \cos \frac{i \pi x}{L}$$

$$I_i = Q_U(0) e^{-\rho_i t} + \int_0^t e^{-\rho_i(\tau-t)} (Q_U^{-1}(\tau) - \beta Q_U(\tau)) e^{-\beta \tau} d\tau$$

$$J_i = cQ_D(0) e^{-\rho_i t} + \int_0^t e^{-\rho_i(t-\tau)} (cQ_D^{-1}(\tau) - c\beta Q_D(\tau)) e^{-\beta \tau} d\tau$$

(8.3.45)

Thus,

$$\begin{aligned} A(x,t) &= \frac{2}{L} \left(\int_0^t Q_U(z) e^{-\beta z} dz \right) \sum_{i=1}^{\infty} (\bar{D}_1/2 \mu_i + \mu_i^{-1}) e^{\bar{D}_1 x/2} \\ &\quad - \frac{2}{L} \left(\int_0^t Q_D(z) e^{-\beta z} dz \right) \sum_{i=1}^{\infty} (-1)^i (\bar{D}_1/2 \mu_i + \mu_i^{-1}) e^{\bar{D}_1/2} \\ &\quad - \frac{2}{L} \sum_{i=1}^{\infty} (\bar{D}_1/2 \mu_i + \mu_i^{-1}) e^{\bar{D}_1 x/2} \left(\int_0^t I_i(z) dz \right) \\ &\quad + \frac{2}{L} \sum_{i=1}^{\infty} (-1)^i (\bar{D}_1/2 \mu_i + \mu_i^{-1}) e^{\bar{D}_1/2} \left(\int_0^t J_i(z) dz \right) \end{aligned} \quad (8.3.46)$$

From the relationship of y and A , $y(x,t)$ might be obtained. It might be noted that,

$$\begin{aligned} \int_0^t I_i(z) dz &= \left(\int_0^t Q_U(0) e^{-\rho_i z} dz \right) \\ &\quad + \int_0^t \int_0^z e^{-\rho_i(z-\tau)} (Q_U^{-1}(\tau) - \beta Q_U(\tau)) e^{-\beta \tau} d\tau dz \end{aligned} \quad (8.3.47)$$

Similar expression holds for

$$\int_0^t J_i(z) dz$$

In the case of stepped up upstream discharge given by

$$Q_u(t) = Q_o,$$

we have,

$$\int_0^t I_i(z) dz = \frac{Q_o}{(\beta - \rho_i)} e^{\rho_i t} - e^{-\beta t} \quad (8.3.48)$$

So that if the downstream gate is controlled to give constant discharge the head build up just upstream of the gate will be mildly exponential.

8.3.11 Integral Method For Controlled Releases

In the main system in order to find the flow build up time, Equation 8.3.46 might be used by a trial and error process. Since this is complex, the integral method might be used to obtain a more convenient formula. The time for the wave front to reach the downstream control point is termed t_L which might be obtained by integrating Equation 8.3.32 or 8.3.39.

Once the wave front has reached $x = L$, let the q profile be

$$q = q_o + b_1 \xi + b_2 \xi^2 + b_3 \xi^3 \quad (8.3.49)$$

Setting the following conditions:

$$\left. \begin{array}{l} q = 0 \text{ at } \xi = 1 \\ \partial^2 q / \partial x^2 = 0 \text{ at } \xi = 0 \end{array} \right\} \quad (8.3.50)$$

and using the integral relationship

$$\left(\frac{\partial q}{\partial x} \right)_{x=L} - \left(\frac{\partial q}{\partial x} \right)_{x=0} = D_L \left\{ \frac{d}{dt} \int_0^L q dx \right\}$$

we obtain the differential equation

$$\frac{da_3}{dt} + \frac{12a_3}{L^2 \bar{D}_2} = 2 \frac{d}{dt} (Q_0 e^{-\beta t}) \quad (8.3.51)$$

On solving (8.3.51) with the initial condition that at $t = t_L$, $a_3 = 1/L$ (comparable with small α_0 in Equation set 8.3.34), we obtain

$$a_3 = Q_0 \left[\frac{1}{2} \left(1 + \frac{2\beta}{\left(-\beta + \frac{12}{L^2 \bar{D}_2} \right)} \right) e^{\left(\frac{12}{L^2 \bar{D}_2} - \beta \right) t_L} \right] e^{-\frac{12}{L^2 \bar{D}_2} t} - \frac{2\beta Q_0 e^{-\beta t}}{\left(-\beta + \frac{12}{L^2 \bar{D}_2} \right)} \quad (8.3.52)$$

Using the continuity equation, the area, time relationship at $x = L$ is given by

$$A = \frac{1}{L} \int_0^t e^{\alpha L t \beta t} [2a_3 - q_0] dt \quad (8.3.53)$$

Using a_3 from equation 8.3.52, we obtain

$$A = \frac{Q_0 e^{\alpha L}}{L} \left[\frac{2A_0 \left(1 - e^{\left(\beta - \frac{12}{L^2 \bar{D}_2} \right) t} \right)}{\frac{12}{L^2 \bar{D}_2} - \beta} + (1 - 2\lambda) t \right] \quad (8.3.54)$$

where

$$A_0 = \frac{1}{2} \left(1 + \frac{2\beta}{\left(-\beta + \frac{12}{L^2 \bar{D}_2} \right)} \right) e^{\left(\frac{12}{L^2 \bar{D}_2} - \beta \right) t_L}$$

and

$$\lambda = \frac{-2\beta}{\beta + \frac{12}{L^2 \bar{D}_2}} \quad (8.3.55)$$

From each discharge characteristic of the regulating structure, the area that would enable the release of stepped up flow requirement downstream might be obtained and used in Equation 8.3.54 to obtain the time of build up.

8.3.12 General Formula For Exponentially Varying Flows

For infinitely long systems we had for $q_0 = Q_0 e^{-\beta t}$

$$q(x,t) = \frac{Q_0 e^{-\beta t}}{2} \left[e^{2\beta_0 x} \operatorname{erfc} \left(\frac{x}{\sqrt{4\alpha t}} + \beta_0 \sqrt{4\alpha t} \right) + e^{-2\beta_0 x} \operatorname{erfc} \left(\frac{x}{\sqrt{4\alpha t}} - \beta_0 \sqrt{4\alpha t} \right) \right]$$

so that

$$Q(x,t) = Q_0 e^{-\beta t} e^{\left(\frac{\bar{D}_1 x}{2} - \frac{\bar{D}_1^2 t}{4\bar{D}_2} \right)} \left[e^{2\beta_0 x} \operatorname{erfc} \left(\frac{x}{\sqrt{4\alpha t}} + \beta_0 \sqrt{4\alpha t} \right) + e^{-2\beta_0 x} \operatorname{erfc} \left(\frac{x}{\sqrt{4\alpha t}} - \beta_0 \sqrt{4\alpha t} \right) \right] \quad (8.3.56)$$

$$\beta_0 = \sqrt{\frac{(-\beta)}{4\alpha}} \quad (8.3.57)$$

$$\text{If now } \beta = -(\bar{D}_1^2/4\bar{D}_2) - \beta_c \quad (8.3.58)$$

where β_0 is a factor to allow for a slow rate of increase of upstream flow

$$\beta_0 = \sqrt{\frac{\bar{D}_1^2}{16} + \frac{\beta_c \bar{D}_2}{4}} \quad (8.3.59)$$

Using (8.3.51) and (8.3.52) in (8.3.49) we have,

$$Q(x,t) = \frac{Q_0}{2} e^{\left(\frac{\bar{D}_1 x}{2} + \beta_c t\right)} \left[e^{2\beta_0 x} \operatorname{erfc}\left(\frac{x}{\sqrt{4\alpha t}} + \beta_0 \sqrt{4\alpha t}\right) + e^{-2\beta_0 x} \operatorname{erfc}\left(\frac{x}{\sqrt{4\alpha t}} - \beta_0 \sqrt{4\alpha t}\right) \right] \quad (8.3.60)$$

From this rate of flow increase

$$\frac{\partial Q}{\partial \tau} = \frac{Q_0}{2} e^{\frac{\bar{D}_1 x}{2} + \beta_c t} \left[e^{2\beta_0 x} \left(\beta_0 \operatorname{erfc} A_1 + \frac{1}{\sqrt{\pi \tau}} A_2 \exp(-A_1^2) \right) + e^{-2\beta_0 x} \left(\beta_c \operatorname{erfc} A_2 + \frac{1}{\sqrt{\pi \tau}} A_2 \exp(-A_2^2) \right) \right] \quad (8.3.61)$$

where

$$A_1 = \frac{x}{\sqrt{4\alpha t}} + \beta_0 \sqrt{4\alpha t} \quad (8.3.62)$$

$$A_2 = \frac{x}{\sqrt{4\alpha t}} - \beta_0 \sqrt{4\alpha t}$$

Thus, from Equation 8.3.46 or Equation 8.3.54, it is possible to obtain the following:

- (i) the time required to reach specified heights at the downstream control point and
- (ii) the free board required in the canal reach for specified upstream and downstream releases.

From Equation 8.3.55 it is possible to determine the effects due to exponentially varying upstream releases.

8.3.13 Release Strategies

When flow is stepped up in the most upstream point of a cascade of canal reaches the flow step diffuses. The whole system may be made to respond quickly by controlling the downstream releases of a given reach at the reference value until the head build up is sufficient to step up the flow as demanded by requirements. This strategy has to be compared with the strategy of controlling the downstream gate in a slowly rising manner allowing the diffused flow due to the upstream step up to convect. The latter strategy results in less than satisfactory flow conditions at the terminal units. In order to rectify this situation, we might allow sufficient time before water is released to the terminal units or allow for variable flow irrigation at the farms which are more likely to bring dissatisfaction amongst farmers. These two strategies are graphically explained through Figures 8.3.3 and 8.3.4. The first strategy due to the reasons mentioned above will be pursued here in this study.

8.3.14 Maximization Of Rate Of Advance Problem Formulation

The rate of advance, dx_a/dt , given by Equation 8.3.32 could be used in an optimization routine as follows:

The rate of advance at a chosen location in the canal may be maximized subject to the constraints due to other considerations. Let this location be given by $x = L$ and the time taken to reach this position be t_L . Now the objective function is

$$\text{Max } Z = \frac{|\lambda_1|}{\lambda_2} \exp(-\bar{D}_1^2 t_L / 2 \bar{D}_2) / \bar{D}_2 \cdot L$$

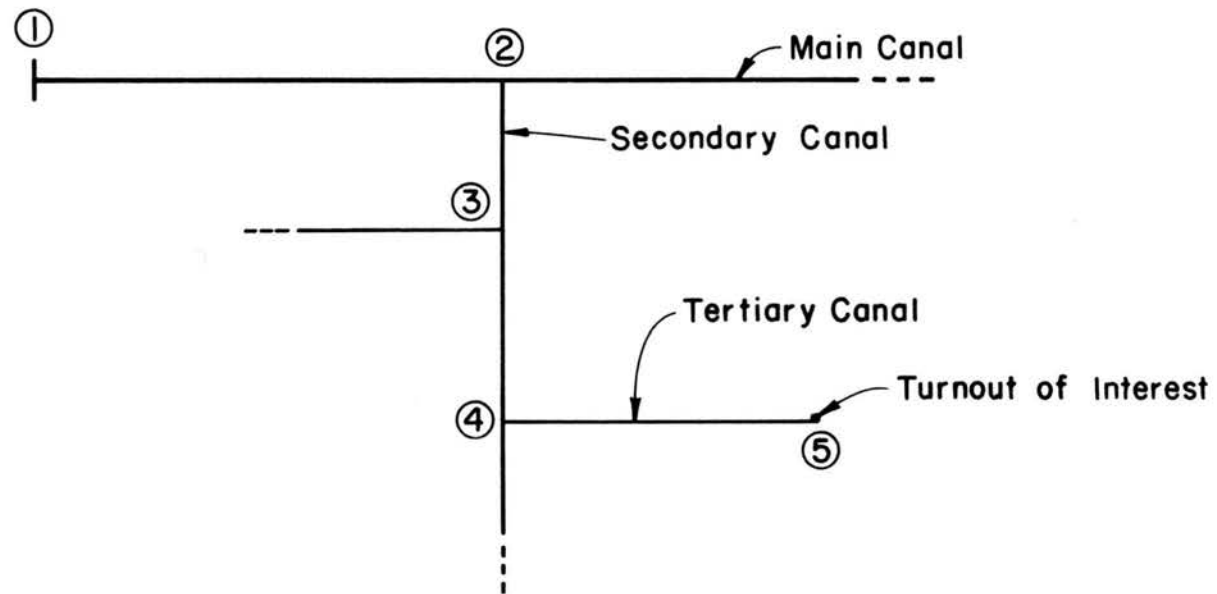

Figure 8.3.3 Idealized Conveyance System Layout

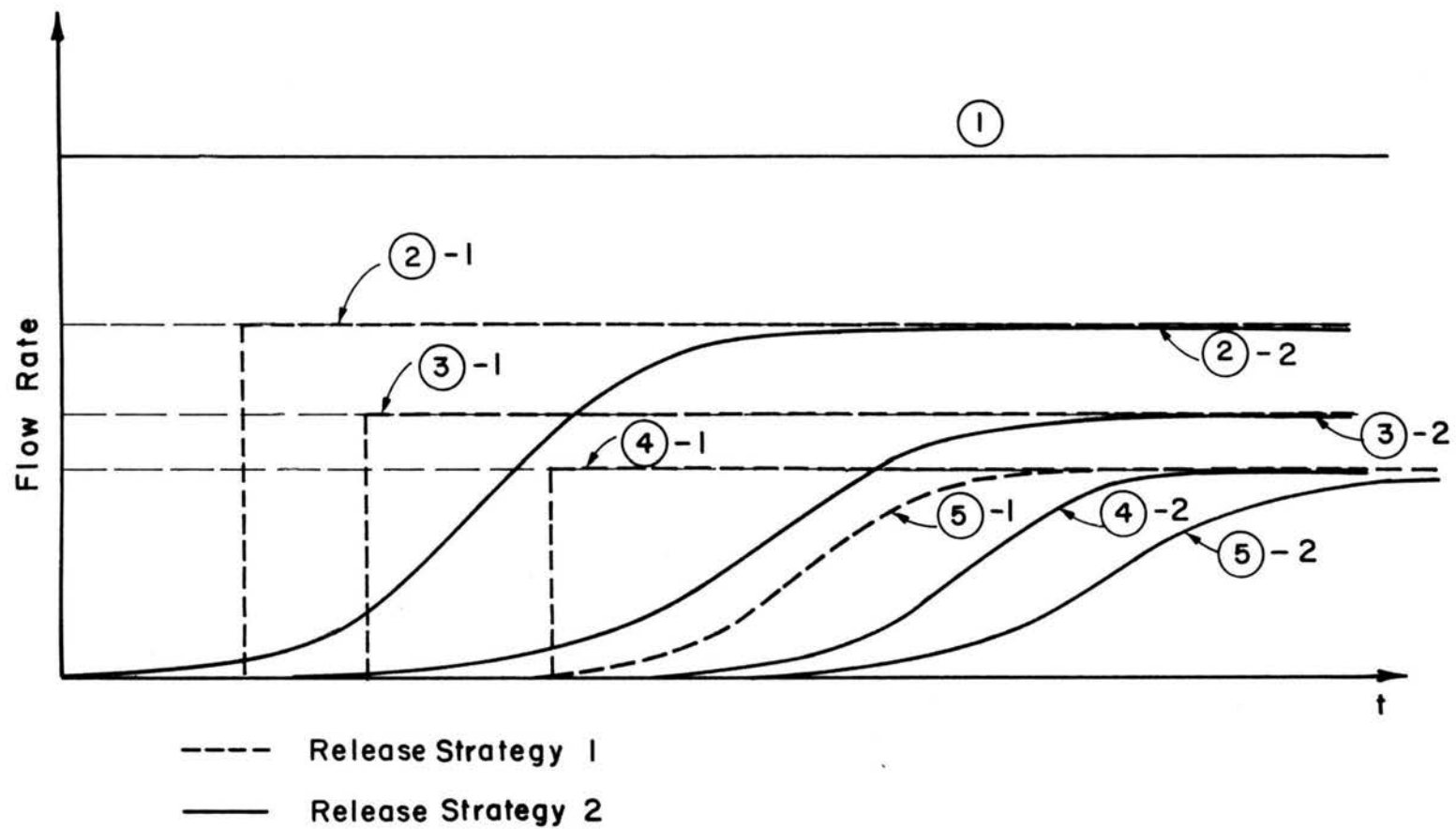

Figure 8.3.4 Flow Curves At Points Of Distribution System

S.t

$$Q_D = CAR^{2/3} \sqrt{S_0} / n$$

$$m_l \leq m \leq m_u$$

$$A_L \leq A \leq A_U$$

$$y_L \leq y \leq y_U$$

This problem may be solved using a scheme such as the Box algorithm (Kuester and Mize (1974)).

8.4 DEVELOPMENT OF OPERATIONAL CRITERIA

8.4.1 Generalities

The water issue strategy module described the optimal strategies of spatial distribution of water. In this section the application of response time models will be demonstrated at the main and secondary canal level. Similar application is possible at the lower hierarchies of the canal system. An important aspect is that the response times are needed at all hierarchies of the canal systems to obtain the operational features of the main canal system.

8.4.2 Problem Formulation

The typical dendritic issue system is shown in Figure 8.4.1. The response time to the first moment of area in the secondary canal, j , is denoted as t_j (Hours) and the response time in main canal from node $(j-1)$ to j is denoted as T_j (Hours).

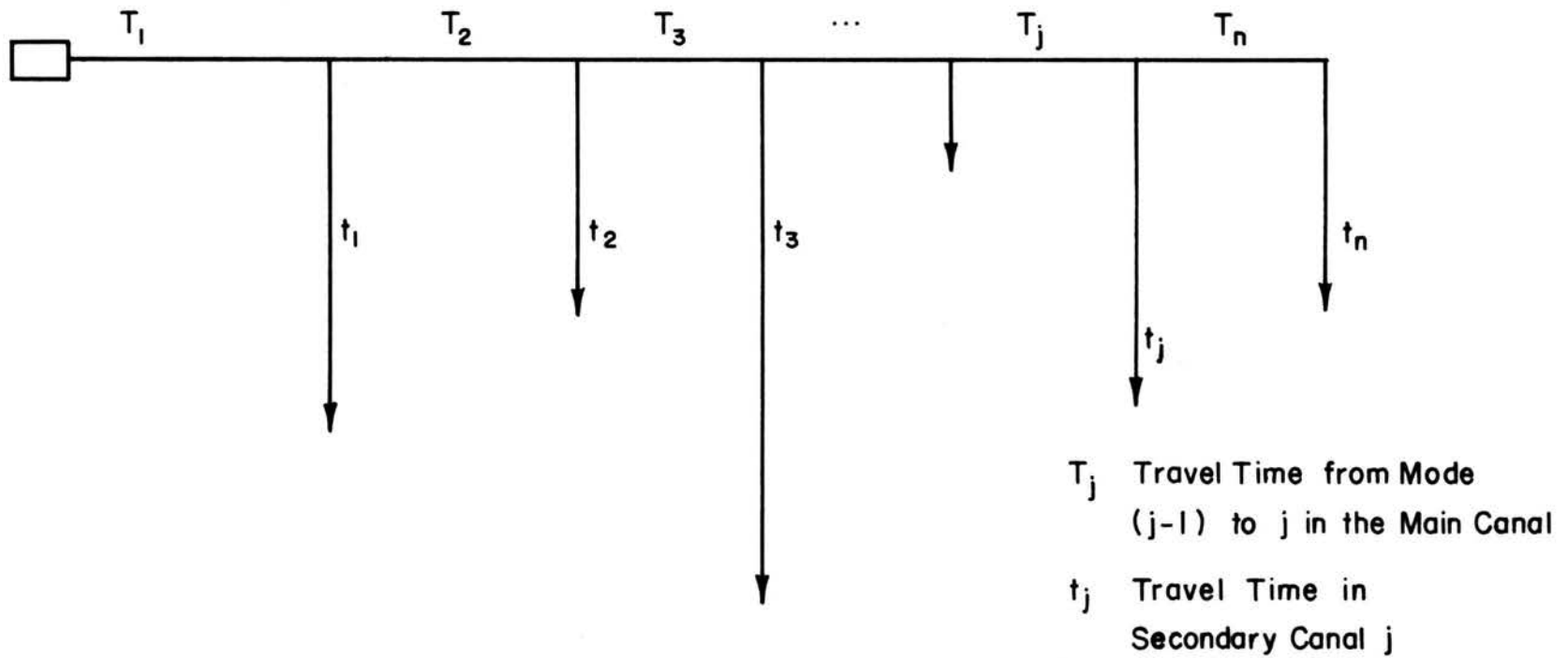

Figure 8.4.1 Typical Layout And Notations Of Travel Time

The reponse time from the reservoir (or source) release point to any area served by the secondary i is given by

$$T_{si} = \left(\sum_{j=1}^i T_j \right) + t_i \quad (8.4.1)$$

where

$$T_j = T_j (\bar{D}_{1j}, \bar{D}_{2j})$$

and

$$t_i = t_i (\bar{D}_{1i}, \bar{D}_{2i}) \quad (8.4.2)$$

It should be noted that factors \bar{D}_{1j} and \bar{D}_{2j} depend on the conditions from which stepping up of flow for the subsequent irrigation is made. The expressions for \bar{D}_{1j} and \bar{D}_{2j} may be obtained from the previous chapter.

Suppose an irrigation is required on day d_1 at say h_1 hours and the previously operating flow values are given. The time on day d_1 (or earlier) at which the main outlet from the source should be open will be given by

$$h_M = h_1 - \text{Max}(T_{si}) \quad \text{for } i = 1, \dots, n \quad (8.4.3)$$

8.4.3 Application of Water Issue Time Solution

In finding T_{si} from Equation 8.4.1, we assume that there are no intermediate reservoirs of any type in the conveyance system. In such a system $\text{Max}(T_{si})$ will in general occur for secondary systems, i , at the tail portions of the project. Thus, the secondary systems will enjoy stepped up releases hours earlier. Table 8.4.1 and 8.4.2 give the data and time required by the secondary systems in System 1 and System 2 to develop 90% of the

flow increments at their terminal points. Tables 8.4.3 and 8.4.4 give the data and times required to build up the area in the downstream checks by 10% for a flow step of 10% from the reference values in System 1 and System 2. Tables 8.4.5 and 8.4.6 give the operational times for the peak irrigations.

It may be observed that the tail systems respond slower than the head systems and the lengths of the systems should be made as small as the situation permits. It may also be seen that intermediate reservoirs are necessary for better response times and water conservation. In the sample problem studied, water is stepped up much earlier than the time of the requirement and may not be really used.

8.5 SUMMARY, CONCLUSIONS AND RECOMMENDATIONS

The linearized Fokker-Planck type diffusion wave equation in Q (flow) was transformed to the classical heat conduction equation. The rate of advance problem and the problem of time required to give specific flow responses such as a given level of flow or a given level of area (or depth) of flow at specified locations of the canal system were studied. The integral method was applied to study the rate of advance problem and also the problem of time required to build up water head at control structures at specified levels. Analytical solutions were developed for the rate of flow increase problem and for the problem of flow and flow area (flow depth) variations in canals of finite length.

Two approaches were tried for the integral method. First it was assumed the $\partial^2 Q/\partial x^2$ vanishes at $x = 0$ and secondly by collocating at $x = 0$. the former resulted in a simpler differential equation in the advance distance x_a . The second approach resulted in a more complex differential equation in x_a and the Runge-Kutta method was applied for its solution.

TABLE 8.4.1

RESPONSE TIME RESULTS FOR SECONDARY SYSTEMS IN SYSTEM I

Secondary Canal #	Average Length of (ft)	Flow (cfs)	Bed Width (ft)	Flow Depth (ft)	Response Time (Hours)
1	4700.0	15.22	6.0	1.50	1.38
2	6100.0	15.97	6.0	1.50	1.62
3	10080.0	20.41	6.0	1.75	2.41
4	7020.0	18.87	6.0	1.75	1.94
5	4800.0	11.74	4.0	1.50	1.40
6	6400.0	16.53	6.0	1.50	1.63
7	5770.0	12.00	4.0	1.50	1.59
8	7200.0	19.47	6.0	1.75	1.92
9	6100.0	15.47	6.0	1.50	1.67
10	7400.0	19.73	6.0	1.75	1.94
11	6600.0	15.66	6.0	1.50	1.76
12	5900.0	10.89	4.0	1.50	1.78
13	4700.0	11.69	4.0	1.50	1.38
14	6520.0	16.20	6.0	1.75	2.13
15	7900.0	17.00	6.0	1.50	1.88
16	6600.0	15.93	6.0	1.50	1.73
17	9200.0	18.61	6.0	1.75	2.46
18	6000.0	15.15	6.0	1.50	1.82
19	5900.0	9.88	4.0	1.50	1.96
20	6480.0	14.64	6.0	1.50	1.86

[All Side Slopes are = 1.5, and bed slopes = .0004]

TABLE 8.4.2

RESPONSE TIME RESULTS FOR SECONDARY SYSTEMS IN SYSTEM 2

Secondary Canal #	Average Length of (ft)	Flow (cfs)	Bed Width (ft)	Flow Depth (ft)	Response Time (Hours)
1	5600.0	12.76	5.0	1.50	1.68
2	6400.0	15.81	6.0	1.50	1.70
3	5780.0	14.78	6.0	1.50	1.68
4	5200.0	12.80	5.0	1.50	1.58
5	7200.0	16.80	6.0	1.50	1.76
6	5900.0	13.87	5.0	1.50	1.61
7	6300.0	16.27	6.0	1.50	1.63
8	4960.0	12.27	5.0	1.50	1.58
9	6800.0	16.53	6.0	1.50	1.71
10	5200.0	12.80	5.0	1.50	1.55
11	8220.0	17.07	6.0	1.50	1.93
12	5860.0	11.99	5.0	1.50	1.85
13	9100.0	15.81	6.0	1.50	2.27
14	6800.0	10.46	4.0	1.50	2.08
15	4880.0	9.19	4.0	1.50	1.81

[All Side Slopes are 1.5 and bed slopes are .0004]

TABLE 8.4.3

RESPONSE TIME RESULTS FOR SYSTEM I

Node #	Length Of Reach (ft)	Flow Depth (ft)	Bed Width (ft)	Flow (cfs)	Response Time (Hours)
1	5280.0	5.50	20.0	314.27	1.07
2	5280.0	5.50	18.0	298.89	1.04
3	7920.0	5.50	18.0	282.76	1.47
4	7920.0	5.50	18.0	262.14	1.59
5	5280.0	5.00	17.0	243.08	1.06
6	5280.0	5.00	15.0	231.22	1.02
7	7920.0	5.00	14.0	214.53	1.39
8	5280.0	5.00	14.0	202.40	1.11
9	5280.0	4.50	14.0	182.74	1.04
10	5280.0	4.50	13.0	167.11	1.08
11	7920.0	4.00	13.0	147.18	1.34
12	5280.0	4.00	11.0	131.36	1.02
13	2640.0	4.00	11.0	120.36	.66
14	5280.0	4.00	11.0	108.56	1.23
15	7920.0	4.00	10.0	92.19	1.78
16	5280.0	4.00	10.0	75.02	1.67
17	5280.0	3.00	8.0	58.93	1.14
18	7920.0	2.50	8.0	40.13	1.73
19	5280.0	2.50	8.0	24.83	2.00
20	7920.0	2.50	6.0	14.98	3.86

[All Side Slopes are 1.5 and Bed Slopes = .0002]

TABLE 8.4.4
 RESPONSE TIME RESULTS FOR SYSTEM 2

Node #	Length Of Reach (ft)	Flow Depth (ft)	Bed Width (ft)	Flow (cfs)	Response Time (Hours)
1	2640.0	5.0	14.0	211.43	.62
2	5280.0	4.5	14.0	198.54	.96
3	5280.0	4.5	14.0	182.57	1.04
4	7920.0	4.5	13.0	167.64	1.42
5	5280.0	4.0	13.0	154.72	.97
6	5280.0	4.0	11.0	137.75	.97
7	10560.0	4.0	11.0	123.74	1.75
8	7920.0	4.0	11.0	107.30	1.63
9	7920.0	4.0	10.0	94.91	1.73
10	5280.0	4.0	10.0	78.21	1.60
11	5280.0	3.0	9.0	65.28	1.11
12	5280.0	3.0	8.0	48.04	1.39
13	5280.0	2.5	8.0	35.93	1.38
14	7920.0	2.5	6.0	19.96	2.90
15	7920.0	2.0	4.6	9.39	4.25

[All Side Slopes are 1.5 and Bed Slopes = .0002]

TABLE 8.4.5
 MAIN SYSTEM OPERATIONAL SCHEDULE
 FOR PEAK IRRIGATION - SYSTEM I

Control Point Number	Time of Gate Opening (Day-Hrs)	
	Main Canal Gate	Secondary Canal Gate
0	189-01.84	
1	189-02.91	189-02.91
2	189-03.95	189-03.95
3	189-05.42	189-05.42
4	189-07.01	189-07.01
5	189-08.07	189-08.07
6	189-09.09	189-09.09
7	189-10.48	189-10.48
8	189-11.59	189-11.59
9	189-12.63	189-12.63
10	189-13.71	189-13.71
11	189-15.05	189-15.05
12	189-16.07	189-16.07
13	189-16.73	189-16.83
14	189-17.96	189-17.96
15	189-19.74	189-19.74
16	189-21.41	189-21.41
17	189-22.55	189-22.55
18	190-00.28	190-00.28
19	190-02.28	190-02.28
20*	190-06.14	190-06.14

*[Irrigation Begins At 190-08.00]

TABLE 8.4.6

MAIN SYSTEM OPERATIONAL SCHEDULE
FOR PEAK IRRIGATION - SYSTEM 2

Control Point Number	Time of Gate Opening (Day-Hrs)	
	Main Canal Gate	Secondary Canal Gate
0	189-6.47	-
1	189-7.09	189-7.09
2	189-8.05	189-8.05
3	189-9.09	189-9.09
4	189-10.51	189-10.51
5	189-11.48	189-11.48
6	189-12.45	189-12.45
7	189-14.20	189-14.20
8	189-15.83	189-15.83
9	189-17.56	189-17.56
10	189-19.16	189-18.16
11	189-20.27	189-20.27
12	189-21.66	189-21.66
13	189-23.04	189-23.04
14	190-01.94	190-01.94
15	190-06.19	190-06.19

However, the difference in the two approaches was not large. Both these two approaches were found to perform well when compared with analytical solutions for a sample problem.

The response problem was studied by comparing the functions $(1/Q \partial Q/\partial t)$ obtained from the analytical solution and (dx_a/dt) obtained from the integral method solution. Both the functions compared well for the sample problem studied. Since the integral method function for (dx_a/dt) was simpler it was used for the formulation of the maximum response problem.

These methods were applied to study the response times in the conveyance systems in the project area studied previously. Systems below the secondary canal systems were assumed to behave like infinitely long systems and the response times to develop 90% of the flow steps were found using the analytical method. In the main canal, the integral method was applied to study the times taken to increase the head build up by given amounts compatible with prescribed discharge characteristics of the check structures. The flow step up was assumed to be 10%, and the area increase at which flow stepping up was assumed to be 10%. From these studies, for the operational criterion that the system should be capable of delivering water on a given day at a given time at any point at the terminal points of the secondary systems in the project area, a sample operational schedule was prepared.

The following are recommended for future research:

- (i) The complete study on the solution of maximum response problem,
- (ii) The study of the effect of intermediate reservoirs in the main canal system, and,
- (iii) The study of the operational features when night irrigation is not possible.

CHAPTER 9

GENERAL RESULTS OF THE OVERALL DESIGN PROCEDURE

9.1 GENERAL RESULTS

The proposed design procedure was applied to a hypothetical project having climatic conditions similar to Cairo, Egypt. Crop benefits, maximum yields and cropping costs are similar to present (1983) values for Egypt. The project details are given in Table 9.1.1. More specific details regarding a particular aspect may be found in the appropriate Module.

The results of the optimal turnout area problem are given in Tables 3.3.1 for the EBT model (Method iii). Assuming that the EBT model sufficiently describes the farmer behavior in the turnout area for the factor of cooperation, $\xi = 0.90$, and the required percentage of success, $xps = 0.80$, we obtain the number of farmers in a turnout area to be = 10.

The results for the depth of requirements are given in Table 4.5.7 of Chapter 4. The results of the flow requirement in different areas are given in Tables 5.4.13 and 5.4.16 of Chapter 5. The results of water table build up are given in Figures 6.5.1 through 6.5.7 of Chapter 6. The results of the water issue strategy analysis for the main canal system are given in Table 7.4.1 and 7.4.2 of Chapter 7. Operational features are given in Table 8.4.3 through 8.4.6 for the main system in Chapter 8.

9.2 ANALYSIS OF THE GENERAL RESULTS

It was found out that in Loop 1 of Figures 2.2.1(a) and 2.2.1 (b) adjustments were not necessary since the long term water table build up was sufficiently contained. Loop 2 was not necessary since the two values were close. The results of flow requirement in different areas show that weighing equity of distribution by a factor of 0.4, the flow variation at the farm level between different areas are in the range of 10%. In larger systems this might make an appreciable difference.

The operational schedule obtained for the peak operation shows the effect of the transients and how they may affect the tail systems if suitable controls are not exercised. They also show that if the tail systems are given priority unless the system has a large canal storage, the frontal systems can waste water. This may be essential if the necessary canal storage cannot be provided due to topographical, economic and other reasons.

TABLE 9.1.1
PROJECT DETAILS

Project Details	Detail
1 Crop Area	20,000 Acres
2 Crops Grown	Cotton, Corn and Rice
3 Average Area Cropping Pattern	1/3 Of Each Crop
4 General Cropping Season	March-October
5 Source Of Water	Reservoir
6 Conveyance System Major Components	Unlined Main Canals, Unlined Secondary and Tertiaries
7 Type of Farm Water Application System	Level Basin
8 Average Farm Size	5 Acres

CHAPTER 10

GENERAL CONCLUSIONS AND RECOMMENDATIONS

The proposed design procedure is an integrated approach to the problem of the design of conveyance systems for surface irrigation projects. The procedure synthesizes the operation and management of systems along with the design and involves steps that hitherto have not been given sufficient emphasis. Six modules were prepared to address the problems associated with these steps. The application of the modules indicate that the design procedure is tenable, relatively inexpensive to compute and transferable to countries where computing facilities are minimal. It is also seen that the problem of design of the conveyance system involves at each major step the selection of an optimum point between system performance and resources available.

These optimal points are not always obtained by a process of single objective optimization. These problems can only be addressed in an interdisciplinary mode. This was emphasized in the design procedure.

The specific recommendations for future research are given in each of the modules. However, some general recommendations are made here:

- (i) A surrogate worth trade off analysis needs to be done for the issue of equity vs maximum benefits farm design model.
- (ii) An implicit stochastic analysis of the problem of project scale farm design under stochastic conditions of:
 - a) Farm system parameters and
 - b) Source water availability,needs to be done.

REFERENCES

- Abbot, M. B., "Computational Hydraulics," Pitman, London, 1979.
- Abdulrazzak, M. J., "Aquifer Recharge from an Ephemeral Stream and Resulting Evolution of Water Table," Hydrowar Program Report, Colorado State University, Fort Collins, Colorado, April 1982.
- Abramowitz, M. and I. A. Stegun, Handbook of Mathematical Functions, Dover Publications, Inc., New York, December 1972.
- Ames, W. F., Nonlinear Partial Differential Equations in Engineering, Vol. IV, Academic Press, 1972.
- Bagadion, B., R. Gamboa, L. Aberamis, and R. C. Lazaro, "The Water Management Training Program of the Upper Pampanga River Project, National Irrigation Administration, Philippines", in Irrigation Policy and the Management of Irrigation Systems in Southeast Asia, Ed. by D. C. Taylor, and T. H. William, The Agricultural Development Council Inc., Bangkok, 1976.
- Bear, J., Hydraulics of Groundwater, McGraw Hill Book Company, New York, 1979.
- Bendt, P., M. Collares-Pereira, and A. Robl, "The Frequency Distribution of Daily Insolation Values", Solar Energy, Vol. 27, pp 1-5, 1981.
- Bhat, U. N., Elements of Applied Stochastic Processes, J. Wiley, New York, 1972.
- BHRA, "Unsteady Flow in Open Channels," proceedings of the International Symposium, Newcastle - upon - Tyne, England, 1976.
- Biga, A. J. and R. Rosa, "Statistical Behavior of Solar Irradiation over Consecutive Days", Solar Energy, Vol. 27, No. 2, pp 149-157, 1981.
- Blank, H. G., "Optimal Irrigation Decisions with Limited Water", in partial fulfillment of the requirements for the Degree of Doctor of Philosophy, Colorado State University, Fort Collins, Colorado, 1975.
- Boonyatharokul, W., "Irrigation Scheduling Soil Moisture Stress Model", dissertation submitted to the Department of Agricultural and Chemical Engineering, Colorado State University, Fort Collins, Colorado in partial fulfillment of the Degree of Doctor of Philosophy, 1979.

- Bromley, D. W., D. C. Taylor, and D. E. Parker, "Water Reform and Economic Development: Institutional Aspects of Water Management in the Developing Countries," *Economic Development and Cultural Change*, Vol. 28, No. 2, January, 1980.
- Burt, J. E., J. T. Hayes, P. A. O'Rourke, W. H. Terjung, and P. E. Todhunter, "A Parametric Crop Water Use Model", *Water Resources Research*, Vol. 17, No. 5, August, 1981.
- Carslaw, H. S. and J. C. Jaeger, Conduction of Heat in Solids, Oxford at Clarendon Press, Second Edition, 1959.
- Chambers, R., "In Search of a Water Revolution: Questions for Canal Irrigation Management in the 1980's," *Water Supply and Management*, Vol. 5, No. 1, 1981.
- Chapman, T. G., "Modelling Groundwater Flow Over Sloping Beds," *Water Resources Research*, Vol. 16, No. 6, pp. 1114-1118, December 1980.
- Chauhan, H. S., G.O. Schuab, and N.Y. Hamdy, "Analytical Computer Solutions of Transient Water Table for Drainage of Sloping Land," *Water Resources Research*, Vol. 4, No. 3, pp. 573-579, June, 1968.
- Clyma, W., Class notes for AE535, "Irrigation System Designs," Colorado State University, Fort Collins, Colorado, Spring, 1979.
- Clyma, W., M. K. Lowdermilk, and G.L. Corey, "A Research Development Process of Improvement of On-Farm Water Management," *Water Management Technical Report No. 47*, June, 1977.
- Coleman, G. and D. G. DeCoursey, "Sensitivity and Model Variance Analysis Applied to Some Evaporation and Evapotranspiration Models", *Water Resources Research*, Vol. 12, No. 5, 1976.
- Coleman, J. S., Introduction to Mathematical Sociology, Free Press of Glencoe, New York, 1964.
- Coleman, J. S., The Mathematics of Collective Action, Aldine Publishing Company, Chicago, 1973.
- Cooper, L. and M.W. Cooper, Introduction to Dynamic Programming, Pergamon Press, pp. 81-83, 1981.
- Cordova, J.R. and R.L. Bras, "Stochastic Control of Irrigation Systems", Report No. 239, Department of Civil Engineering, Massachusetts Institute of Technology, Cambridge, Massachusetts, 1979.
- Coward, Jr., E. W., "Irrigation Management Alternatives: Themes from Indigenous Irrigation Systems," *Agricultural Administration*, (4), 1977.
- Coward, Jr., E. W. "Research Methodology in the Study of Irrigation Organization - A Review of Approaches and Application," Seminar Report No. 18, The Agricultural Development Council, Inc., December, 1978.

- Cox, D. R. and Miller, H. D., The Theory of Stochastic Processes, Wiley, New York, 1965.
- Cunge, J. A. and F. M. Holly, Jr., Practical Aspects of Computation of River Hydraulics, Pitman Advanced Publishing Program, Boston.
- Daly, C. J., "Analytical/Numerical Methods for Groundwater Flow and Quality Problems," dissertation submitted in partial fulfillment of the requirement for degree of Doctor of Philosophy, Colorado State University, Fort Collins, Colorado, 1979.
- Davenport, D. C., "Variations of Evaporation in Time and Surface, 1. Study of Diurnal Changes using Evaporimeters and Grass Lysimeters", Journal of Hydrology, 5 (1967) pp 312-328, 1967.
- De Los Reyes, R. P., "Stereotypes and Facts in Irrigation Management: Preliminary Findings from a Case Study of a Philippine Communal System," in Irrigation Policy and the Management of Irrigation Systems in Southeast Asia, Ed. by: D. C. Taylor, and T. H. Wickam.
- Dooge, J. C. I., "Linear Theory of Hydrologic Systems," Technical Bulletin No. 1468, USDA, 1973.
- Doorenbos, J. and W.O. Pruitt, "Guidelines for Predicting Crop Water Requirements", Irrigation and Drainage Paper No. 24, FAO, Rome, 1975, 1977.
- Dressler, R. F., "Hydraulic Resistance Effect Upon the Dam-Break Functions," Journal of Research of the National Bureau of Standards, Vol. 49, No. 3, September 1952.
- Dudley, N. J., D. T. Howell, and W. F. Musgrave, "Optimal Intraseasonal Irrigation Water Allocation", Water Resources Research, Vol. 7, No. 4, August, 1971.
- Dudley, N.J., W.F. Musgrave, and D.T. Howell, "Irrigation Planning 3. The Best Size of Irrigation Area for a Reservoir", Water Resources Research, Vol. 8, No. 1, Feb. 1972.
- Dumm, L. D., "Transient Flow Concept in Subsurface Drainage," transaction of the ASAE, Vol. 7, No. 2, pp. 142-146, 151, 1964.
- Dumm, L.D. and R.J. Winger, "Subsurface Drainage System Design for Irrigated Area Using Transient Flow Concept," transactions of the ASAE, Vol. 7, No. 2, pp. 147-151, 1964.
- Durnford, D. S., "Optimal Drain Design: An Incremental Net Benefit Approach," dissertation submitted in partial fulfillment of the requirements for the Degree of Doctor of Philosophy, Colorado State University, Fort Collins, Colorado, 1982.
- Eagleson, P., Dynamic Hydrology, McGraw Hill, New York, 1970.

- Eagleson, P. S., "Climate Soil and Vegetation, 2. The Distribution of Annual Precipitation Derived from Observed Storm Sequences", *Water Resources Research*, Vol. 14, No. 5, Oct. 1978.
- Early, A. C., M. K. Lowdermilk, and D. M. Freeman, 1978c, "Farm Irrigation Constraints and Farmer's Responses: Comprehensive Field Survey in Pakistan," Volume III, Water Management Technical Report No. 48-C, September, 1978.
- El-Hakim, Omnia, "Quality Parameter Functions for Border Irrigation and Their Water Management Applications," Unpublished Ph.D. Dissertation, Colorado State University, Fort Collins, Colorado, 1984.
- El-Kady, M., J. Wolfe, and H. Wahby, "The Rotation Water Distribution System vs. the Continual Flow Water Distribution System," Technical Report no. 20, Egypt Water Use and Management Project, Cairo, Egypt, April, 1982.
- Feddes, R. A., P. Kowalik, S. P. Neuman, and E. Bresler, "Finite Difference and Finite Element Simulation of Field Water Uptake by Plants", *Hydrological Sciences Bulletin*, XXI, 1, 3/1976.
- Freeman, D. M., M. K. Lowdermilk, and A. C. Early, 1978a, "Farm Irrigation Constraints and Farmers' Responses: Comprehensive Field Survey in Pakistan," Volume V, Water Management Technical Report No. 48-E, September, 1978.
- Freeman, D. M., M. K. Lowdermilk, and A. C. Early, 1978b, "Farm Irrigation Constraints and Farmers' Responses: Comprehensive Field Survey in Pakistan," Volume VI, Water Management Technical Report No. 48-F, September, 1978.
- FAO, 1970, "Farm Water Management Seminar Manila," Irrigation and Drainage Paper 12, FAO, Rome 1972
- Gardner, W.R., "Availability and Measurement of Soil Water," in *Water Deficits and Plant Growth*, edited by Kozlowski, T. T., Vol. I, Academic Press, New York, 1968.
- Gardner, W. R., W. A. Jury, and J. Knight, "Water Uptake by Vegetation" in Heat and Mass Transfer in the Biosphere, ed. by Devries, D. A., and Afgan, N. H., John Wiley, New York, 1975.
- Glover, R. E., "Transient Ground Water Hydraulics," *Water Resources Publications*, Fort Collins, Colorado, 1978.
- Gates, T. K., "Improving Design of a Furrow Irrigation System for Improved Seasonal Performance," M. S. thesis, Department of Ag. and Chemical Engineering, Colorado State University, Spring, 1980.

- Gates, T. K., W. O. Ree, and M. Helal, "Hydraulic Design of a Canal System for Gravity Irrigation at Abyuya," draft report, Egypt Water Use and Management Project, Colorado State University, Fort Collins, Colorado, 1983.
- Hall, W. A. and W. S. Butcher, "Optimal Timing of Irrigation," Journal of the Irrigation and Drainage Division, ASCE, Vol. 94, Jr. 2, June 1968.
- Hall, W. A. and N. Buras, "Optimum Irrigated Practice Under Conditions of Deficient Water Supply," transactions of ASAE, Vol. 4, No. 1, pp 131-134, 1961.
- Hanks, R. J., "Model for Predicting Plant Yield as Influenced by Water Use", Agronomy Journal, Vol. 66. pp 660-665, 1974.
- Hart, W.E., "Irrigation System Design", Department of Agricultural and Chemical Engineering, Colorado State University, Fort Collins, Colorado 80523, 1975.
- Hart, W. E. and A. T. Corey, "Soil Water Engineering," Department of Ag and Chemical Engineering, Colorado State University, Fort Collins, Colorado 80523, 1974.
- Hildebrand, F. B., Introduction to Numerical Analysis, McGraw-Hill Book Company, New York, 1956.
- Hiler, E. A. and T. A. Howell, "Optimization of Water Use Efficiency Through Trickle Irrigation and the Stress Day Index", Tech. Rep. #62, Texas Water Resources Institute, Texas A & M University, December, 1974.
- Hillel, D., "Soil and Water Physical Principles and Processes," Academic Press, New York, 1971.
- Hunt, R. C. and E. Hunt, "Canal Irrigation and Local Social Organization," Current Anthropology, Sept. 17, 1976.
- Idso, S. B. and R. D. Jackson, "Thermal Radiation from the Atmosphere", Journal of Geophysical Research, 74: 5397-5403, 1969.
- Jenkins, G.M. and D. G. Watts, "Spectral Analysis and its Applications," Holden - Day, San Francisco, 1968.
- Jensen, M.E., "Water Consumption by Agricultural Plants", Water Deficits and Plant Growth, edited by T. T. Kozlowski, Vol. II, Academic Press, New York, 1968.
- Jensen, M. E., (ed.) "Consumptive Use of Water and Irrigation Water Requirements", American Society of Civil Engineers, New York, 1973.
- Jensen, M. E. and H.R. Haise, "Estimating Evapotranspiration from Solar Radiation," Journal of Irrigation and Drainage, ASCE, Vol. 89, IR4, 1963.

- Jensen, M. E., D. C. N. Robb, and C. E. Franzoy, "Scheduling Irrigations Using Climate - Crop - Soil Data," *Journal of the Irrigation and Drainage Division, ASCE*, Vol. 96, No. IR1, March, 1970.
- Katapodes, N.D. and D.R. Schamber, "Applicability of Dam Break Flood Wave Models," *Journal of Hydraulic Engineering, ASCE*, Vol. 109, No. 5, May, 1983.
- Keefer, T.N. and R.S. McQuivey, "Multiple Linearization Flow Routing Model," *Journal of Hydraulics Division, ASCE*, Vol. 100, No. HY7, July, 1974.
- Kincaid, D. C. and D. F. Heerman, "Scheduling Irrigations Using a Programmable Calculator," U. S. Department of Agriculture, ARS Report No. ARS-NG-12, 14 Pages, 1974.
- Lazarsfeld, P. F. (ed), Mathematical Thinking In The Social Sciences, Free Press, Glencoe, Illinois, 1954.
- Ley, T., W. Clyma, "Furrow Irrigation Design," Class notes for AE 535, Colorado State University, Fort Collins, Colorado, 1980.
- Liu, B. Y. H. and R.C. Jordan, "The Interrelationship and Characteristic Distribution of Direct, Diffuse and Total Solar Radiation," *Solar Energy*, No. 4, pp. 1-19, 1960.
- Lof, G. O. G., J. A. Duffie, and C. O. Smith, "World Distribution of Solar Radiation," *Solar Energy*, Vol. 10, No. 1, 1966.
- Lowdermilk, M.K., D.M. Freeman, and A.C. Early, "Farm Irrigation Constraints and Farmers' Responses: Comprehensive Field Survey in Pakistan," *Water Management Technical Report No. 48-D*, Vol. IV, Colorado State University, Fort Collins, Colorado. September 1978.
- Lowdermilk, M. K., A. C. Early, and D. M. Freeman, 1978a, "Farm Irrigation Constraints and Farmers' Responses: Comprehensive Field Survey in Pakistan," Volume I, *Water Management Technical Report No. 48-A*, September, 1978.
- Lowdermilk, M. K., D. M. Freeman, and A. C. Early, 1978b, "Farm Irrigation Constraints and Farmers' Responses: Comprehensive Field Survey in Pakistan," Volume II, *Water Management Technical Report No. 48-B*, September, 1978.
- Lowdermilk, M. K., D. M. Freeman, and A. C. Early, 1978c, "Farm Irrigation Constraints and Farmers' Responses: Comprehensive Field Survey in Pakistan," Volume IV, *Water Management Technical Report No. 48-C*, September, 1978.
- Marlatt, W. E., A. V. Havens, N. A. Willitts, and G. O. Brill, "A Comparison of Computed and Measured Soil Moisture Under Snap Beans," *J. Geophysical Research*, 66:535-541, 1961.
- Maasland, M., "Water Table Fluctuations Induced by Intermittent Recharge," *Journal of Geophysical Research*, Vol. 64, No. 5, 1959.

- Mahmood, K. and V. Yevjevich, (ed.), "Unsteady Flow in Open Channels," Vol. I, II and III, Water Resources Publications, P. O. Box 303, Fort Collins, Colorado, 80522, 1975.
- McCuen, R. H., "A Sensitivity and Error Analysis of Procedures used for Estimating Evaporation," Water Resources Bulletin, Vol. 10, No. 3, June, 1974.
- McWhorter, D. B., "Drain Spacing Based on Dynamic Equilibrium," ASCE, Journal of Irrigation and Drainage, Vol. 103, No. IR2, June 1977.
- Merrey, D.J., "Irrigation and Honor: Cultural Impediments to the Improvement of Local Level Water Management in Punjab, Pakistan," Water Management Technical Report No. 53, December, 1979.
- Mirza, A.H., D.M. Freeman, and J.B. Eckert, 1975, "Village Organizational Factors Affecting Water Management Decision-Making Among Punjabi Farmers," Water Management Technical Report No. 35, March, 1975.
- Mirza, A. H. and D. J. Merrey, "Organizational Problems and Their Consequences on Improved Watercourses in Punjab", Water Management Technical Report No. 55, December, 1979.
- Moodie, M. J., "Flexible Case Management for the Implicit Solution of Border Irrigation," Unpublished M. S. Thesis, Colorado State University, Fort Collins, Colorado, 1979.
- Morel-Seytoux, H.J., and C.T. Daly, "A Discrete Kernel Generator for Stream-Aquifer Studies," Water Resources Research, Vol. II, No. 2, April, 1975.
- Nairizi, S. and J. R. Rydzewski, "Effects of Dated Soil Moisture Stress on Crop Yields," Experimental Agriculture, Vol. 13, pp. 51-59, 1977.
- Nemhauser, G. L., Dynamic Programming, John Wiley and Sons, London, 1966.
- Neghassi, H. M., "Crop Water Use and Yield Models with Limited Water," dissertation submitted in partial fulfillment of the requirements for the degree of Doctor of Philosophy, Department of Agricultural and Chemical Engineering, Colorado State University, Fort Collins, Colorado, 1974.
- Nimah, M. N. and R. J. Hanks, "Model for Estimating Soil Water, Plant and Atmospheric Interrelations: 1. Description and Sensitivity," Soil Science Soc., Amer., Proc., Vol. 37, 1973.
- Oad, R., "Water Management and Relative Water Supply in Irrigation Systems of Indonesia," unpublished Ph.D. thesis, Cornell University, Ithaca, Jan. 1982.
- Özisik, M. N., "Heat Conduction," John Wiley and Sons, New York, 1980.

- Pasternak, B., "Social Consequences of Equalizing Irrigation Access," Human Organization, Vol. 27, No. 4, Winter, 1968.
- Peck, A. J., R. J. Luxmoore, and J. L. Stolzy, "Effects of Spatial Variability of Soil Hydraulic Properties in Water Budget Modelling," Water Resources Research, Vol. 13, No. 2, April 1977.
- Penman, H. L., "Natural Evaporation from Open Water, Bare Soil and Grass," proc. Roy. Soc. (London), a 193, pp. 120-145, 1948.
- Ponce, V. M., "Simplified Muskingum Routing Equation," Journal of Hydraulics Division, ASCE, Vol. 105, No. HY1, January, 1979.
- Ponce, V. M., "Unsteady Flow in Open Channels," (Volumes I and II) class notes for CE696BV, group study in Hydraulics, Colorado State University, Fort Collins, Colorado, Spring, 1980.
- Ponce, N.M. and V. Yevjevich. "Mulkingum-Cunge Method with Variable Parameters," Journal of Hydraulic Division, ASCE, Vol. 104, No. HY12, December, 1978.
- Ponrajah, A. J. P., "Scheduling of Irrigations," Technical Note No. 7, Irrigation Department, Columbo, Sri Lanka, February, 1981.
- Price, R. K., "A River Catchment Flood Model," Proc. of Institution of Civil Engineers, Part 2, Vol. 65, pp. 655-668. September, 1978.
- Rau, J. G., Optimization and Probability in Systems Engineering, Von Nostrand, Reinhold Company, New York, 1970.
- Reddy, J.M., "Irrigation System Improvement by Simulation and Optimization," dissertation in partial fulfillment of the requirements for the degree of Doctor of Philosophy, Colorado State University, Fort Collins, Colorado, 1980.
- Reddy, J. M., and Clyma, W., "Chosing Optimal Design Depth for Surface Irrigation Systems," Agricultural Water Management, 6 (1983), 335, 349, 1983.
- Reddy, J. M. and W. Clyma, "Optimal Design of Furrow Irrigation Systems," Paper #80-2071 presented at the ASAE Summer meeting at San Antonio, Texas, June, 1980.
- Richardson, C. W., "Stochastic Simulation of Daily Precipitation, Temperature and Solar Radiation," Water Resources Research, Vol. 17, No. 1, pp. 182-190, 1981.
- Roach, G. F., "Green's Functions," Cambridge University Press, Cambridge, Stuttgart, 1981.
- Rubenstein, L. I., "The Stefan Problem," American Mathematical Society, Providence, Rhode Island, 1971.

- Rudloff, W., "World Climates," Wissenschaftliche, Verlagsgesellschaft, mbh, 1982.
- Sagardoy, J. A., A. Bottrall, and G. O. Uittenbogaard, "Organization Operation and Maintenance of Irrigation Schemes," FAO Irrigation and Drainage Paper 40, FAO, Rome, 1982.
- Sagar, B., "Solution of Linearized Boussinesq Equation with Boundaries and Recharge," Water Resources Research, Vol. 15, No. 2, June 1979.
- Schetz, J. A., "Analytic Approximations of Boundary - Layer Problems," Journal of Applied Mechanics, pp. 425-428, transactions of ASME, 1966.
- Sharma, M. L. and R. J. Luxmoore, "Soil Spatial Variability and Its Consequences on Simulated Water Balance," Water Resources Research, Vol. 15, No. 6, December 1979.
- Singh, S. R. and C. M. Jacob, "Transient Analysis of Phreatic Aquifers Lying Between Two Open Channels," Water Resources Research, Vol. 13, No. 2, April, 1977.
- Sritharan, S., "Seepage from Canals -- State of the Art," (1982a) Unpublished Report submitted to Prof. D. Sunada for the Ph.D. preliminary examination, Summer, 1982.
- Sritharan, S., "Derivations of Open Channel Equations," (1982b) class notes for group study in AE795, Colorado State University, 1982.
- Stackgold, I., "Boundary Value Problems of Mathematical Physics," Vol. II., Macmillan, New York, 1968.
- Strelkoff, T. S. and N. D. Katopodes, "Border Irrigation Hydraulics with Zero-Inertia," Journal of the Irrigation and Drainage Division, ASCE, Vol. 103, No. IR3, Sept. 1977.
- Swartman, R.K. and O. Ogunlade, "Solar Radiation from Common Parameters," Solar Energy, Vol. II, Nos. 3 and 4, 1967.
- Tabbal, D. F. and S. I. Bhuiyan, 1982, "Design Parameters for Effective Water Distribution in Diversion Irrigation Systems in the Philippines," Paper No. 82-2080, Presented at the Summer Meeting of ASAE, June, 1982.
- Taylor, D.C., and T.H. Wickham, (Ed.) 1976, "Irrigation Policy and the Management of Irrigation Systems in Southeast Asia," The Agricultural Development Council, Inc., Bangkok, 1979.
- Thavaraj, S. H., "The Importance of Integrating Non-Engineering Aspects in Irrigation System Design," in Irrigation policy and Management of Irrigation Systems in Southeast Asia, ed. by Taylor, D. C. and Wickam, T. H., The Agricultural Development Council, Inc., Bangkok, 1976.

- Thornthwaite, C. W. and J. R. Mather, "The Water Budget and its Use in Irrigation," in, Water, U. S. D. A. Yearbook, 1955, U. S. Government Printing Office, Washington, 1955.
- Todorovic, P. and D. A. Woolhiser, "Stochastic Model of Daily Rainfall," Proc. Symposium on Statistical Hydrology, Tucson, Arizona (1971), USDA, M.S.C. Pub. No. 1275, pp. 232-246.
- Torgersen, W. S., Theory and Methods of Scaling, Wiley, New York, 1958.
- Van Bavel, C. H. M., "Potential Evaporation: The Consideration Concept and Its Experimental Verification," Water Resources Research, Vol. 2, No. 3, 1966.
- VanderMeer, C., "Water Theivery in a Rice Irrigation System in Taiwan," Annals of the Association of American Geographers, March, 1971.
- W.M.O., "Short Period Averages for 1951-1960 and Provisional Average Values for Climate Temp. and Climate Temp. Ship Stations," WMD/OMM, No: 170, pp. 84, Geneva, Switzerland, 1965.
- Wade, R., "Performance of Irrigation Projects," Economic and Political Weekly, 17th January, 1976.
- Wade R., and R. Chambers, "Managing the Main System: Canal Irrigation's Blind Spot," Review of Agriculture, Economic and Political Weekly, September, 1980.
- Windor, J. S. and Ven Je Chow, "Model for Farm Irrigation in Humid Areas," Journal of Irrigation and Drainage Division, ASCE, Vol. 97, IR3, September, 1971.
- Werner, P. W., "Some Problems in Non-Artesian Ground Water Flow," Transactions, American Geophysical Union, Vol. 38, No. 4, August, 1957.
- Woodroffe, M., Probability With Applications, McGraw Hill, New York, 1975.
- Yaron, D., "Estimation and Use of Water Production Functions in Crops," Journal of the Irrigation and Drainage Division, ASCE, Vol. 97, No. IR2, June 1971.

APPENDICES

APPENDIX 3.1

RESULTS OF EBTM WITH PRESCRIBED DISTRIBUTIONS

TABLE A 3.1

RESULTS OF EBTM WITH BETA DISTRIBUTION WITH $\alpha = 3$ and $\beta = 2$

Number in the Group	Probability of Getting Required or More Fraction of Success				
	Required Fraction of Success				
	75%	80%	85%	90%	95%
10	.45	.45	.31	.31	.18
12	.37	.37	.24	.24	.14
14	.41	.30	.30	.20	.11
16	.34	.34	.25	.16	.09
18	.38	.29	.21	.14	.07
20	.33	.33	.25	.18	.11
22	.36	.29	.22	.15	.10
24	.32	.25	.19	.14	.09
26	.34	.28	.17	.12	.08
28	.31	.25	.20	.10	.07
30	.33	.28	.18	.13	.06
32	.30	.26	.16	.12	.05
34	.33	.23	.19	.11	.05
36	.30	.26	.17	.10	.04
38	.32	.24	.16	.09	.04
40	.30	.26	.18	.11	.06
42	.29	.22	.15	.10	.05
44	.29	.22	.15	.10	.05
46	.31	.24	.14	.09	.05
48	.29	.22	.16	.08	.04
50	.31	.24	.15	.10	.04

TABLE A 3.2

RESULTS OF EBTM WITH BETA DISTRIBUTION WITH $\alpha = 5$ and $\beta = 3$

Number in the Group	Probability of Getting Required or More Fraction of Success				
	Required Fraction of Success				
	75%	80%	85%	90%	95%
10	.65	.65	.49	.49	.30
12	.56	.56	.41	.41	.25
14	.61	.48	.48	.34	.20
16	.54	.54	.42	.29	.17
18	.59	.48	.37	.25	.14
20	.53	.53	.43	.32	.22
22	.57	.48	.38	.29	.19
24	.52	.43	.34	.25	.17
26	.55	.48	.31	.23	.15
28	.51	.44	.36	.21	.13
30	.54	.48	.33	.26	.12
32	.51	.44	.30	.23	.11
34	.54	.41	.34	.21	.10
36	.50	.44	.32	.20	.09
30	.53	.42	.30	.18	.08
40	.50	.45	.33	.22	.12
42	.52	.42	.31	.21	.11
44	.50	.40	.29	.19	.10
46	.52	.42	.28	.18	.10
48	.49	.40	.31	.17	.09
50	.52	.43	.29	.20	.08

APPENDIX 3.2
RESULTS OF 2X2 MCM

TABLE A 3.3

RESULTS OF 2X2 MCM WITH REQUIRED FRACTION OF SUCCESS = .75

Number in the Group	Probability of Getting Required or More Fraction of Success				
	$\alpha' = .02$	$\alpha' = .03$	$\alpha' = .04$	$\alpha' = .05$	$\alpha' = .07$
	$\beta' = .02$	$\beta' = .03$	$\beta' = .06$	$\beta' = .05$	$\beta' = .03$
10	.88	.82	.78	.74	.64
12	.84	.78	.72	.67	.58
14	.83	.76	.71	.66	.55
16	.80	.72	.66	.61	.50
18	.79	.71	.65	.60	.47
20	.76	.68	.61	.55	.44
22	.75	.67	.60	.54	.42
24	.72	.63	.56	.50	.38
26	.72	.63	.56	.50	.37
28	.69	.60	.52	.46	.34
30	.68	.59	.52	.46	.32
32	.66	.56	.49	.43	.30
34	.66	.56	.49	.43	.29
36	.63	.53	.46	.40	.27
38	.63	.53	.46	.40	.26
40	.61	.50	.43	.37	.24
42	.60	.50	.43	.37	.23
44	.58	.48	.41	.35	.21
46	.58	.48	.41	.35	.21
48	.56	.46	.39	.33	.19

APPENDIX 3.3
RESULTS OF 4X4 MCM

TABLE A 3.4
RESULTS OF 4X4 MCM

Number in the Group	Expected Percentage of Visits to States*			
	State 1	State 2	State 3	State4
10	67	8	4	12
12	65	10	3	14
14	63	11	3	15
16	61	13	3	17
18	58	14	3	19
20	56	15	3	20
22	54	16	3	22
24	52	17	3	24
26	50	19	3	25
28	48	19	3	26
30	47	20	2	27
32	45	21	2	28
34	43	22	2	29
36	42	23	2	30
38	40	24	2	31
40	39	24	2	32
42	38	25	2	33
44	37	26	2	34
46	35	26	2	34
48	34	27	2	35
50	33	27	2	36

*Rounded

APPENDIX 4.1

INITIAL TRAJECTORIES FOR THE OPTIMAL
SCHEDULING PROBLEM

APPENDIX 4.1

GENERAL ALGORITHM FOR INITIAL TRAJECTORIES FOR SOIL MOISTURE STATUS AND WATER APPLICATIONS

Our objective is to maximize

$$Y = K_1^{\lambda_1} K_2^{\lambda_2} K_3^{\lambda_3} K_4^{\lambda_4} \dots K_n^{\lambda_n} \quad (\text{A4.1.1})$$

Where K_i is the soil moisture stress coefficient.

The state equations are:

$$\theta_1 = \theta_0 + u_1 - k_1 e_1$$

$$\theta_2 = \theta_1 + u_2 - K_2 e_2$$

(A4.1.2)

$$\theta_i = \theta_{i-1} + u_i - k_i e_i$$

$$\theta_n = \theta_{n-1} + u_n - k_n e_n$$

where θ_i are end of the stage soil moisture content, u_i are the applied water and e_i are the evapotranspiration during state i all in units of depth. Let

$$\sum_{i=1}^n u_i = w, \text{ where } w \text{ is the total seasonal water applied.} \quad (\text{A4.1.3})$$

From the state equations

$$\theta_n - \theta_o = w - \sum_{i=1}^n K_i e_i,$$

i.e.

$$\sum_{i=1}^n K_i e_i = w + (\theta_o - \theta_n) \quad (\text{A4.1.4})$$

Let us assume that we can control k_i with u_i and k_i and e_i are independent.

The problem now is

$$\text{Max } y = \left\{ \prod_{i=1}^n (K_i)^{\lambda_i} \right\} \quad (\text{A4.1.5})$$

S.T

$$\sum_{i=1}^n K_i e_i = w + \theta_o - \theta_n = x \quad (\text{A4.1.6})$$

and

$$\theta \leq K_i \leq 1$$

$$i = 1, 2, \dots, n$$

The Lagrangian is:

$$\begin{aligned} L(K_i, \mu_i) &= \prod_{i=1}^n (K_i)^{\lambda_i} + \mu_o \left(x - \sum_{i=1}^n K_i e_i \right) \\ &+ \sum_{i=1}^n \mu_i (1 - K_i) - \sum_{i=1}^n \mu_{n+i} K_i, \end{aligned} \quad (\text{A4.1.7})$$

for

$$i = 1, 2, 3, \dots, n$$

Let

$$f(\mathbf{K}) = \prod_{i=1}^n (K_i)^{\lambda_i}, \quad (\text{A4.1.8})$$

$$\mathbf{x} - \mathbf{g}_0(\mathbf{K}) = \left(\mathbf{x} - \sum_{i=1}^n K_i \mathbf{e}_i \right), \quad (\text{A4.1.9})$$

and

$$\mu_i - g_i(\mathbf{K}) = \mu_i (1 - K_i) \quad (\text{A4.1.10})$$

The Kuhn-Tucker conditions at a local extremum for this problem are:

KT-1

$$\frac{\partial f(\mathbf{K})}{\partial K_j} - \mu_0 \mathbf{e}_j - \mu_j - \mu_{n+j} \leq 0, \quad (\text{A4.1.11})$$

(strict equality at passive constraints)

KT - 2

$$\text{Either, } \frac{\partial f(\mathbf{K})}{\partial K_j} - \mu_0 \mathbf{e}_j - \mu_j - \mu_{n+j} = 0 \text{ (at passive constraints), } (\text{A4.1.12})$$

$$\text{or } K_j = 0 \text{ (at active constraints of non negativity)} \quad (\text{A4.1.13})$$

KT - 3

This is

$$\mathbf{x} - \sum_{i=1}^n K_i \mathbf{e}_i = 0 \quad (\text{A4.1.14})$$

$$0 \leq K_i \leq 1$$

KT -4

$$\mu_0 \left(x - \sum_{i=1}^n K_i e_i \right) + \sum_{i=1}^n \left\{ \mu_i (1-K_i) - \mu_{n+i} K_i \right\} = 0 \quad (\text{A4.1.15})$$

i.e.

$$\mu_0 \left(x - \sum_{i=1}^n K_i e_i \right) = 0 \quad \text{say } \mu_0 g_0 = 0 \quad (\text{A4.1.16})$$

$$\mu_i (1 - K_i) = 0 \quad \text{Say } \mu_i g_i = 0 \quad (\text{A4.1.17})$$

$$\sum_{i=1}^n \mu_{n+i} K_i = 0 \quad \text{Say } \mu_{n+i} g_i^* = 0 \quad (\text{A4.1.18})$$

i. e.

At active constraints $g_i = 0$

At passive constraints $\mu_i = 0$

We might expect for the problem at hand that the non negativity constraints are passive

i.e.

$$\mu_{n+i} = 0 \quad (\text{A4.1.19})$$

$$i = 1, 2, \dots, n$$

The solution procedure begins by assuming that the $K_i \leq 1$ constraints are passive. That is

$$\mu_i = 0 \quad (\text{A4.1.20})$$

$$i = 1, 2, \dots, n$$

Now in the problem given by Equation (A4.1.15) subject to constraints given by Equation (A4.1.16), as a starting procedure let us assume K_i is free,

Then,

$$y = \prod_{i=1}^n (K_i)^{\lambda_i} = \left\{ \prod_{i=1}^{n-1} (K_i)^{\lambda_i} \right\} \left(\frac{x - \sum_{i=1}^{n-1} K_i e_i}{e_n} \right)^{\lambda_n} \quad (\text{A4.1.21})$$

$$\therefore \frac{\partial y}{\partial K_j} = \frac{\lambda_j}{K_j} \prod_{i=1}^{n-1} (K_i)^{\lambda_i} \left(\frac{x - \sum_{i=1}^{n-1} K_i e_i}{e_n} \right)^{\lambda_n}$$

$$+ \prod_{i=1}^{n-1} (K_i)^{\lambda_i} (-e_j) \lambda_n \left(\frac{x - \sum_{i=1}^{n-1} K_i e_i}{e_n} \right)^{\lambda_n - 1} \quad (\text{A4.1.22})$$

On setting

$$\frac{\partial y}{\partial K_j} = 0$$

we get

$$\frac{\lambda_j}{K_j} = \frac{e_j \lambda_n}{x - \sum_{i=1}^{n-1} K_i e_i} \quad (\text{A4.1.23})$$

$$j = 1, 2, \dots, n-1$$

i.e.

$$\frac{\lambda_j}{e_j K_j} = \frac{\lambda_n}{\left(x - \sum_{i=1}^{n-1} K_i e_i \right)} \quad (\text{A4.1.24})$$

i.e.

$$\frac{\lambda_j}{e_j^{K_j}} = \frac{\lambda_1}{e_1^{K_1}} = \frac{\lambda_2}{e_2^{K_2}} \cdots = \frac{\lambda_n}{e_n^{K_{n-1}}} \quad (\text{A4.1.25})$$

from Equation (1.24),

$$\lambda_j \left(n - \frac{e_j K_j}{\lambda_j} \sum_{i=1}^{n-1} \lambda_i \right) = e_j^{K_j} \lambda_n,$$

i.e.

$$e_j^{K_j} \left(\sum_{i=1}^n \lambda_i \right) = \lambda_j^n$$

$$K_j = \frac{x \lambda_j}{\left(e_j \sum_{i=1}^n \lambda_i \right)} \quad (\text{A4.1.26})$$

The steps now would be:

(1) Check to see whether any K_j violates $0 \leq K_j \leq 1$.(2) Set aside $K_j \leq 0$.(3) For most $K_j = \frac{(n\lambda_j)}{e_j \left(\sum_{i=1}^n \lambda_i \right)} \leq 1$ Say $j \in J_a$, Set $K_j = 1$ (4) Let $j \in J_a$ be J_p

$$\frac{\partial f(K)}{\partial K_j} = \mu_0 e_j \text{ for } j \in J_p \quad \text{and}$$

$$x - \sum_{i \in J_a} e_i = \sum_{i \in J_p} K_i e_i$$

Now the solution as before is

$$K_j = \frac{\left(x - \sum_{i=J}^a e_i \right) \lambda_j}{e_j \sum_{i \in J_p} \lambda_i} \quad j \in J_p \quad (\text{A4.1.27})$$

(5) If this is violated this process may be repeated until KTII are satisfied.

Once the optimal K_i 's are found the decision variables may be found as follows using Equation Set (2). Suppose we have n_1 values of K_2 that are equal to 1.0 and the rest $< 1.0^2$.

Then,

$$K_i = \left(\frac{\theta_i + \theta_{i-1}}{2} \right) \frac{1}{r_i cb} \quad K_i \leq 1 \quad (\text{A4.1.28})$$

when r_i root depths, c the available water (L/L), and b a coefficient.

i.e.

$$\left(\frac{\theta_i + \theta_{i-1}}{2 r_i cb} \right) \geq 1 \quad K_i = 1 \quad (\text{A4.1.29})$$

Let the mean set for which $K_i = 1$ be

$$= [m_1, m_2, m_3, \dots, m_{n_1}] \quad (\text{For example, } = [3, 7, 9, 14])$$

For these values of i

$$\theta_i + \theta_{i-1} - 2 r_i cb \geq 0 \quad (\text{A4.1.30})$$

For the other i

$$\theta_i + \theta_{i-1} = 2 K_i r_i cb = 0 \quad (\text{A4.1.31})$$

Thus, in addition to Equation Set (2) we have

$$\theta_i + \theta_{i-1} - 2 r_i cb = n_i \quad (n_i \geq 0) \quad (\text{A4.1.32})$$

For

$$i = m_1, m_2, \dots, m_{n_1}$$

We have for the rest $(n - n_1) K_i \theta_i + \theta_{i-1} = 2 r_i$ cb K_i values of i ,

The numbers of unknown are given from the following:

Unknown	Number
x_{-i}	n_1
θ_i	$(n-1)$
n_i	n
TOTAL	$\frac{(2n+n_1 - 1)}{\quad}$

The total number of equations we have is $2n$.

This indicates the solution is now unique and we set arbitrarily $x_i = 0$ for m_2, m_3, \dots, m_{n_1} .

A computer program called CROPMAX was developed for this procedure and the results for irrigation of corn with 900 mm is given as an example in the following table.

Stage Number	K	Soil Moisture Status At The End of The Stage (mm)	Water to Be Applied (mm)
1	1.000	24.05	45.88
2	1.000	174.98	388.96
3	1.000	71.62	320.90
4	.655	90.00	144.27

At stage 1, the shortfall from the wilting point is about 6mm and stage 3 is about 20 mm. These may be adjusted by setting to their lower bounds and if these are negligible we already have a solution for the step 1 of the optimizing problem.

APPENDIX 4.2

AVERAGE SOIL MOISTURE COMPUTATIONS FOR
STAGEWISE OPTIMAL ALLOCATION OF WATER

APPENDIX 4.2

AVERAGE SOIL MOISTURE DURING A STAGE

For the dynamic programming computations for the stagewise optimal irrigation decisions, we found that the stage return functions depend on the average soil moisture during the stage. One option for the computation of soil moisture during a stage is to compute the average of initial and final soil moistures during a stage.

This procedure gives low values of the objective function. This might be improved by the following analysis:

Let the following be the notation:

- θ - Soil moisture at time t
- θ_1 - The initial soil moisture
- u - The rate at which the crop is irrigated (assumed constant during a stage)
- e - The rate of our potential evaporation (assumed constant during a stage)
- U - The total irrigation during the stage
- E - The total crop potential evaporation during a stage
- l - The time length of the stage
- $\bar{\theta}$ - The average soil moisture
- $g(\theta)$ - The moisture stress function

$$\frac{d\theta}{dt} = u - g(\theta) e \quad (\text{A4.2.1})$$

Using Boonyatharakol's (1979) modified linear fit,

$$g(\theta) = \frac{\theta}{brc} \quad \text{if } \theta \leq br$$

$$= 1 \quad \text{if } \theta < br$$

where $b = 0.548$, and r the depth of the zone studied (root depth) and c the soil moisture content per unit depth. Since this function is discrete, and if used in (2.1) make the integration cumbersome, first a power curve of the type θ^β was fixed. This is done by minimizing the integral

$$y = \int_0^b \left(\frac{\theta}{b} - \theta^\beta \right)^2 d\theta + \int_b^1 (1 - \theta^\beta) d\theta$$

$$y = 1 - \frac{2b}{3} + \frac{2b^\beta}{(\beta+1)\beta+2} - \frac{(3\beta+1)}{(\beta+1)(2\beta+1)}$$

The value of β that minimizes y for $b = 0.55$ is found out to be 0.94. In order to facilitate the computations even more β is assumed to be 1.0.

Thus equation (2.1) is

$$\frac{d\theta}{dt} = u - \frac{\theta}{brc} e \quad (\text{A4.2.2})$$

The solution of (2.2) with the initial soil moisture content $\theta = \theta_1$ is given by

$$\theta = \left(\theta_1 - \frac{brcu}{e} \right) \exp(-et/brc) + \frac{brcu}{e} \quad (\text{A4.2.3})$$

The average $\bar{\theta}$ of θ during the time length ℓ is therefore given by,

$$\bar{\theta} = \frac{1}{\ell} \int_0^{\ell} \theta dt \quad (\text{A4.2.4})$$

$$= \frac{1}{\ell} \int_0^{\ell} \left\{ \left(\theta_1 - \frac{\text{brc}u}{e} \right) \exp(-et/\text{brc}) + \frac{\text{brc}u}{e} \right\} dt$$

$$= \frac{\text{brc}U}{E} + \left(\theta_1 - \text{brc} \frac{U}{E} \right) \left\{ \frac{\text{brc}}{E} \left(\exp(-E/\text{brc}) \right) \right\}$$

$$\bar{\theta} = \frac{\text{brc}}{E} \left\{ U + \left(\theta_1 - \text{brc} \frac{U}{E} \right) \left(1 + \exp(-E/\text{brc}) \right) \right\}$$

APPENDIX 4.3

MINIMUM MEAN SQUARE FITTING OF FUNCTIONS

APPENDIX 4.3

FITTING OF RELATIONSHIPS OF THE TYPE

$$(1 - y_a/y_m) = k_y (-ET_a/ET_m)$$

TO THE TYPE OF $y_a/y_m = (ET_a/ET_m)^\lambda$

Let

$$y = y_a/y_m \text{ and } ET_a/ET_m = \theta$$

Then,

$$(1 - y_a/y_m) = k_y (1 - ET_a/ET_m) \tag{A4.3.1}$$

is

$$y = k_y \theta + (1 - k_y) \tag{A4.3.1a}$$

and

$$y_a/y_m = (ET_a/ET_m)^\lambda \tag{A4.3.2}$$

is

$$y = \theta^\lambda \tag{A4.3.2a}$$

An approximation of (A4.3.1a) by (A4.3.2a) is given by minimizing

$$L = \int_0^1 [k_y \theta + 1 - k_y - \theta^\lambda]^2 d\theta$$

$$L = (1 - 2k_y/3) - 2(1 - k_y)/(\lambda + 1) - 2k_y/(\lambda + 2) + 1/(2\lambda + 1) \tag{A4.3.3}$$

Setting

$$\partial L / \partial \lambda = 0$$

we have

$$\partial L / \partial \lambda = 2(1-k_y)/(\lambda+1)^2 + 2k_y/(\lambda+2)^2 - 2/(2\lambda+1)^2 = 0 \quad (\text{A4.3.4})$$

i.e.

$$1-k_y/(\lambda+1)^2 + k_y/(\lambda+2)^2 - 1/(2\lambda+1)^2 = 0 \quad (\text{A4.3.5})$$

$$\lambda(3\lambda+2)(\lambda+2)^2 - k_y(2\lambda+3)(2\lambda+1)^2 = 0 \quad (\text{A4.3.6})$$

Thus the solution for λ is given by Equation 3.6.

An initial solution for Equation 4 may be given by setting $k_y/(\lambda+2)^2 = 0$ or $1-k_y/(\lambda+1)^2 = 0$ in Equation 3 the assumptions being that k_y or $(1-k_y)$ is small respectively. This gives

$$\lambda = \frac{1 - \frac{1-k_y}{-1}}{2 - \frac{1-k_y}{-1}}$$

or

$$\lambda = \frac{2 - k_y}{2k_y - 1} \quad (\text{A4.3.7})$$

In the case of $k_y > 1$, since we would not prefer a negative yield at $\theta=0$, it is preferable to minimize the

$$L' = \int_0^a \theta^{2\lambda} d\lambda + \int_a^1 [k_y \theta + 1 - k_y - \theta^\lambda]^2 d\theta \quad (\text{A4.3.8})$$

where

$$a = \frac{k_y - 1}{k_y}$$

$$L' = \frac{a^{2\lambda+1}}{(2\lambda+1)} + \int_0^1 a^{2\lambda+1} [(1-k_y) + k_y \theta^{-\lambda}]^2 d\theta$$

$$= \frac{a^{2\lambda+1}}{(2\lambda+1)} + \int_0^1 a^{2\lambda+1} [(1-k_y)^2 + 2(1-k_y)(k_y \theta^{-\lambda}) + (k_y \theta^{-\lambda})^2] d\theta$$

$$L' = C + L + \left[-2(1-k_y) \frac{a^{\lambda+1}}{\lambda+1} + \frac{2k_y}{(\lambda+2)} a^{\lambda+2} - \frac{a^{\lambda+1}}{2\lambda+1} \right] \quad (\text{A4.3.9})$$

where

$$C = \left[a(1-k_y)^2 + a^2 k_y (1-k_y) + \frac{a^3 k_y}{3} \right]$$

Setting $\partial L' / \partial \lambda = 0$ as before

we have

$$\frac{\partial L'}{\partial \lambda} = \frac{\partial L}{\partial \lambda} - \frac{\partial L'}{\partial \lambda} \quad (\text{A4.3.10})$$

where

$$L' = +2(1-k_y) \frac{a^{\lambda}}{(\lambda+1)} + \frac{2k_y}{(\lambda+2)} a^{\lambda+2} + \frac{a^{2\lambda+1}}{2\lambda+1} \quad (\text{A4.3.11})$$

From Equations (A4.3.10) and (A4.3.11) value of λ may be obtained.

APPENDIX 5.1

IRRIGATION PERFORMANCE OF FURROW IRRIGATION SYSTEMS

APPENDIX 5.1

QUALITY PARAMETER FUNCTIONS FOR FURROW IRRIGATION

The furrow irrigation system designs are presently based on an empirical advance function proposed by SCS and an approximate volume balance approach (Ley and Clyma (1980)). In this section expressions for irrigation quality parameters such as application efficiency, E_a , requirement efficiency, E_r , runoff ratio, R_r , and deep percolation ratio, R_p , will be derived. The notations in Ley and Clyma (1980) will be followed here. The advance to distance x is given by

$$T_t = g x^h \quad (A5.1.1)$$

where g is given by

$$g = \frac{j k^d Q^d S_o^{d/2}}{C_2} \quad (A5.1.2)$$

where, h , k , Q , C_2 , are functions of the infiltration characteristic of the soil and j is a factor for units used. The approach of Sritharan (1981) is used here.

Let us assume that the storage depletion time and the recession time are negligible (Ley and Clyma (1980)). Thus, the distribution of infiltrated depth is given as (See Figure A 5.1.1)

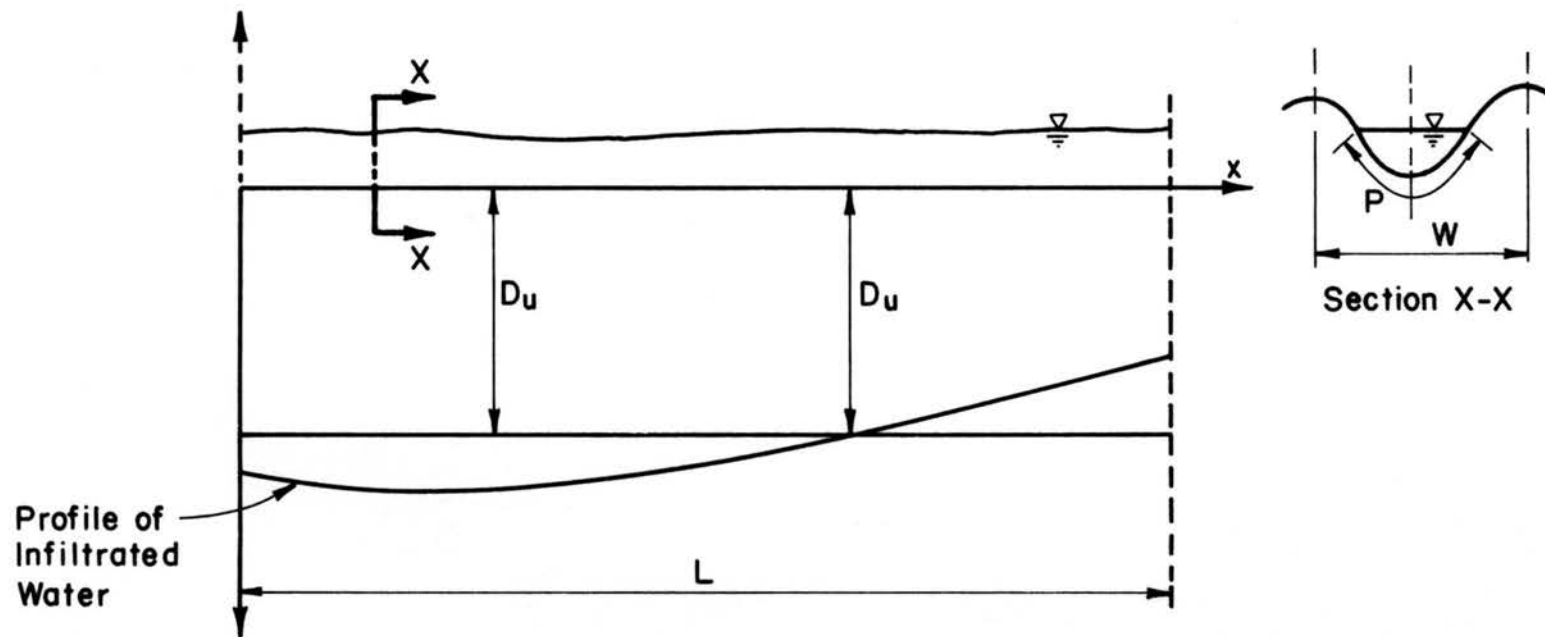

Figure A5.1.1 Profile Of Infiltrated Water

$$D_x = [a(T_1 - gx^h)^b + C] \left(\frac{P+K}{W}\right) \quad (\text{A5.1.3})$$

where P is the wetted perimeter, K is an empirical coefficient to account for both vertical and horizontal intake and W the furrow spacing.

Thus, the amount of water added to the root zone for the plant use = D_{au} is given by

$$D_{au} = \frac{L_0}{L} D_u + \frac{1}{L} \int_{L_0}^L (a(T_1 - gx^h)^b + C) \left(\frac{P+K}{W}\right) dx \quad (\text{A5.1.4})$$

where

$$L_0 = \left\{ \frac{1}{g} \left[T_1 - \left\{ \frac{D_u}{a} \left(\frac{W}{P+K}\right) - \frac{c}{a} \right\}^{1/b} \right] \right\}^{1/h} \quad (\text{A5.1.5})$$

if $0 \leq L_0 \leq L$.

If L_0 as given by Equation (A5.1.5) is < 0 , then $L_0 = 0$ or $L_0 = L$ respectively.

Thus, the requirement efficiency is given by

$$\begin{aligned} E_r &= D_{au}/D_u \\ &= \frac{L_0}{L} + \left(\frac{L-L_0}{L}\right) \frac{C}{D_u} \left(\frac{P+K}{W}\right) \\ &\quad + \frac{a}{D_u} \frac{P+K}{WL} \int_{L_0}^L (T_1 - gx^h)^b dx \end{aligned} \quad (\text{A5.1.6})$$

$$E_r = \frac{L_o}{L} \left[1 - \frac{C(P+K)}{D_u W} \right] + \left(\frac{P+K}{D_u W L} \right) (CL + a \int_{L_o}^L (T_1 - g x^h)^b dx)$$

(A5.1.7)

$$E_r = \frac{L_o}{L} \left[1 - \left(\frac{C(P+K)}{D_u W} \right) + \left(\frac{P+K}{D_u W} \right) \left(C + a T_1^b \right. \right. \\ \left. \left. \left\{ 1 - \frac{L_o}{L} + \sum_{r=1}^{\infty} \frac{b(b-1) \dots (b-r+1)}{r! (hr+1)} \left(\frac{-g}{T_1} \right)^r (1^{hr} - L_o^{hr} \frac{L_o}{L}) \right\} \right) \right]$$

(A5.1.8)

Application efficiency E_a is given by

$$E_a = D_{au}/D_a = WLD_{au}/QT_1$$

where

$$\therefore E_a = \frac{WL}{QT_1} D_u \left\{ \frac{L_o}{L} \left(1 - \frac{C(P+K)}{D_u W} \right) + \left(\frac{P+K}{D_u W} \right) \left(C + a T_1^b \right. \right. \\ \left. \left. \left\{ 1 - \frac{L_o}{L} + \sum_{r=1}^{\infty} \frac{b(b-1) \dots (b-r+1)}{r! (hr+1)} \left(\frac{-g}{T_1} \right)^r (1^{hr} - L_o^{hr} \frac{L_o}{L}) \right\} \right) \right\}$$

(A5.1.9)

In the above equations P is given by

$$P = a_1 \left(\frac{Qn}{\sqrt{S_0}} \right)^{b_1} \quad (\text{A5.1.10})$$

where Q is the furrow inflow rate, n the Manning's roughness coefficient and S_0 the furrow slope.

The deep percolation depth DPD is given by

$$\text{DPD} = \left(\frac{P+K}{W} \right) \frac{1}{L} \left\{ \int_0^{L_0} a_1 (T_1 - g x^h)^b + C \, dx - D_u L_0 \right\}$$

for $L_0 > 0 \Rightarrow 0$ for $L_0 = 0$ (A5.1.11)

i.e., For $L_0 > 0$,

$$\text{DPD} = \left(\frac{P+K}{LW} \right) \left\{ (C-D_u) L_0 + a T_1^b \left(L_0 + \sum_{r=1}^{\infty} T_r \left(\frac{-g x^h}{T_1} \right)^r \right) \right\} \quad (\text{A5.1.12})$$

where

$$T_r = \frac{b(b-1)\dots(b-r+1)}{r!(hr+1)}$$

The deep percolation ratio DP is given by

$$\text{DP} = \text{DPD}/(\text{QT}_1)/\text{WL} \quad (\text{A5.1.13})$$

Non-Dimensional Parameters For Furrow Irrigation

The requirement efficiency, E_r , of a furrow may be expressed as

$$E_r = f_1 (S, I, L, T_a, W, D_u, Q, \eta_R) \quad (A5.1.14)$$

where

- S = Furrow slope (ft/ft) (L/L),
- I = SCS Intake family number (terminal intake rate (L/T)),
- L = Length of the furrow (ft) (L),
- T_a = Time of application (minutes) (T),
- W = Furrow spacing (ft) (L),
- D_u = Requirement depth (ft) (L), and
- η_R = Non-dimensional roughness parameter
- Q = Furrow flow in GPM

Similarly the deep percolation D_p is given by

$$D_p = h_1 (S, I, L, T_a, W, D_u, Q, \eta_R) \quad (A5.1.15)$$

Using the Buckingham's Pi Theorem, taking L and T_a as fundamental parameters the following relationship might be obtained for fined roughness parameter η_R ,

$$E_r = f (S, IT_a/L, D_u/L, W/L, QT_a/L^3, \eta_R) \quad (A5.1.16)$$

$$D_p = h (S, IT_a/L, D_u/L, W/L, QT_a/L^3, \eta_R) \quad (A5.1.17)$$

The various Pi values and the E_r and D_p are given in Table A 5.1 for $n_R = .04$.

Regression resulted in the following expressions,

$$E_r = \frac{0.047863}{S^{0.13}} \left(\frac{I^{0.142} T_a^{0.283}}{D_u^{.254} W^{.289}} \right) \frac{Q^{0.141}}{L^{0.017}} \quad (\text{A5.1.18})$$

with an $r^2 = 66.4\%$ (See Figure A 5.1.2) and

$$D_p = 10^{-37.4} \frac{I^{3.59} T_o^{5.33} Q^{1.74} L^{0.29}}{S^{6.07} D_a^{3.50} W^{5.60}} \quad (\text{A5.1.19})$$

with an $r^2 = 74.8\%$.

Since the r^2 is low further improvement on this was made by the following regression for E_r

$$E_r = \sum_{i=0}^5 a_i x^i \quad (\text{A5.1.20})$$

where

$$x = \frac{.047863}{S^{0.10}} \left(\frac{I^{.142} T_a^{.283}}{D_u^{.254} W^{.289}} \right) \frac{Q^{.141}}{L^{0.017}}, \quad a_0 = -3.065, a_1 = 19.179,$$

$a_2 = -46.879$, $a_3 = 67.132$, $a_4 = -49.736$ and $a_5 = 14.277$ which has an $r^2 = 81\%$. The data for this regression is given in Table A5.1.1. Since the SCS advance function is still not exact (Clyma, (1979)), we might still use the relationship for E_r .

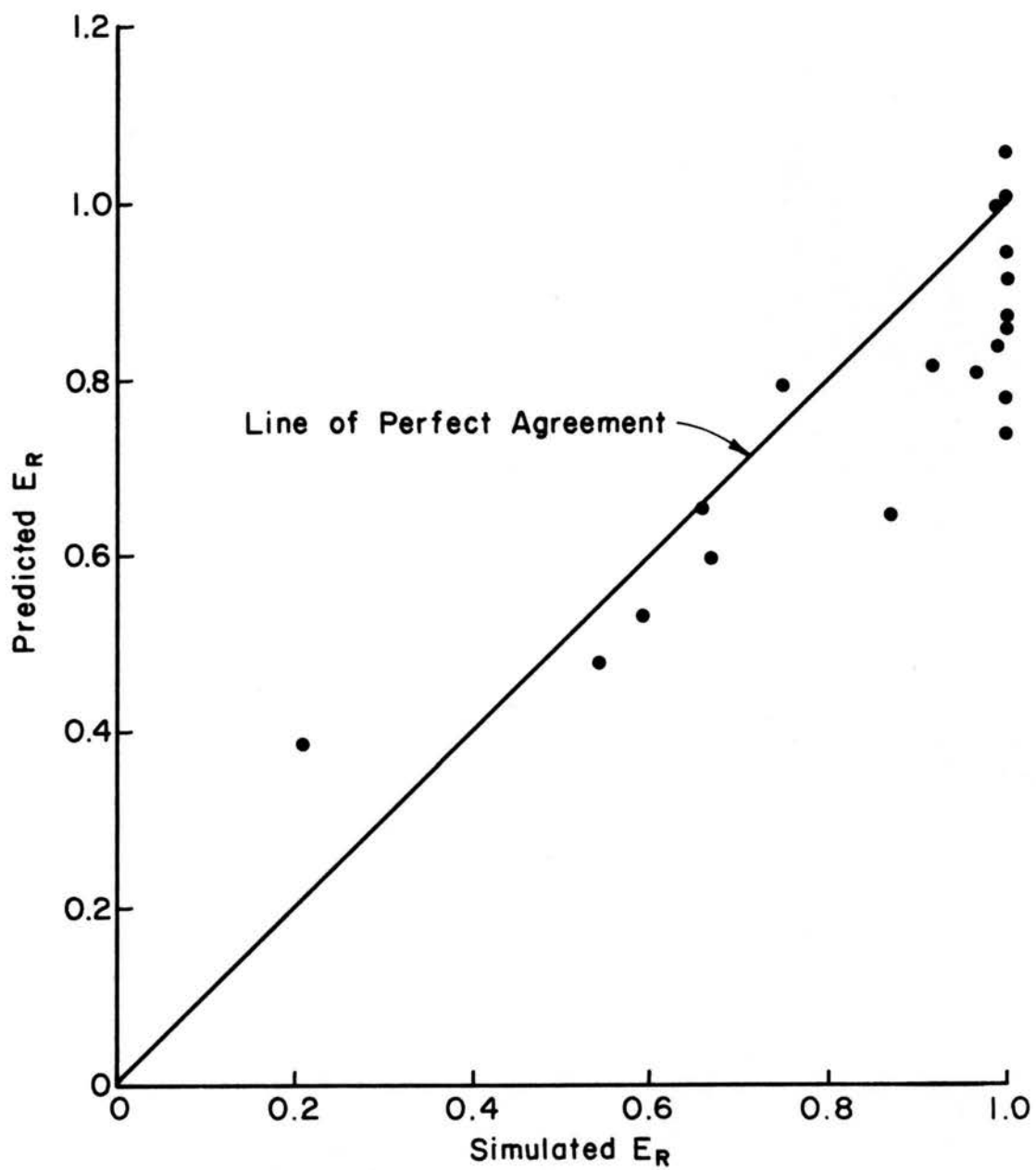

Figure A 5.1.2 Prediction Formula Performance For E_R For Furrows

TABLE A. 5.1.1 SIMULATION RESULTS FOR FURROW SYSTEMS

S	IT_a/L	D_u/L	W/L	QT/L^3	E_r	D_p
0.005	0.10	0.40 E-02	.116 E-01	.1 E-02	0.208	.0
0.005	0.01	0.40 E-03	.116 E-02	.7 E-05	0.542	.0
0.005	0.07	0.40 E-03	.116 E-04	.35 E-04	0.751	.0
0.005	0.07	0.20 E-03	.190 E-02	.7 E-05	0.661	.0
0.005	0.07	0.20 E-03	.19 E-02	.35 E-04	0.916	.0
0.003	0.38	0.20 E-02	.580 E-02	.281 E-03	0.668	.0
0.003	1.88	0.20 E-02	.580 E-02	.41 E-02	1.0	.009
0.003	0.42	0.44 E-03	.129 E-02	.154 E-04	1.0	.34
0.003	0.50	0.20 E-02	.190 E-01	.10 E-02	0.589	.0
0.003	0.35	0.20 E-03	.190 E-02	.7 E-03	1.0	.048
0.001	0.80	0.16 E-02	.464 E-02	.256 E-03	1.0	.0183
0.001	0.84	0.21 E-02	.200 E-02	.187 E-04	1.0	.0899
0.001	1.00	0.40 E-02	.116 E-01	.100 E-02	0.872	.0
0.001	0.70	0.20 E-02	.190 E-01	.35 E-01	1.0	.0059
0.001	0.07	0.20 E-03	.190 E-02	.35 E-04	1.0	.0547
0.0008	1.00	0.13 E-02	.387 E-02	.556 E-04	0.973	.0508
0.0008	1.00	0.67 E-03	.643 E-02	.556 E-04	0.99	.0658
0.0008	1.50	0.65 E-03	.306 E-02	.278 E-04	0.989	.098
0.0008	1.29	0.56 E-03	.262 E-02	.175 E-04	0.778	.098
0.0008	1.50	0.49 E-03	.229 E-02	.156 E-04	0.740	.119

APPENDIX 5.2

IRRIGATION PERFORMANCE OF LEVEL BORDER IRRIGATION

APPENDIX 5.2

QUALITY PARAMETER FUNCTIONS FOR LEVEL BORDER IRRIGATION

Level border irrigation, when given SCS type infiltration functions can be simulated using the Zero-Inertia approach (Strelkoff, Moodie (1979)). Since a non-dimensional approach with the non-dimensional parameter of El Hakim (1983) a dimensional approach as adopted by Reddy (1980) was attempted including the infiltration characteristics as well. This regression again did not yield good correlation coefficient. Then the infiltration characteristic was excluded and regression was attempted for the different soil groups separately. The Tables A 5.2.1 to A 5.2.4 give the simulation results which were used for regression. Table A 5.2.5 gives the results of regression for the requirement efficiency and the corresponding coefficient of correlation. The regressions for the deep percolation did not yield satisfactory results.

TABLE A 5.2.1 RESULTS OF SIMULATION ON LEVEL BASINS
 $I = 0.1$ Family, Mannings $n = 0.15$

D_u (In)	q (cfs/ft)	T (Min)	L (ft)	E_r	D_r	E_r From Formula
3.75	.0190	90.0	350.0	.849	0.0	.86
3.00	.0220	45.0	300.0	.768	0.0	.72
2.90	.0195	50.0	260.0	.780	0.0	.83
2.50	.0190	24.0	250.0	.462	0.0	.48
3.50	.0250	84.0	500.0	.837	0.0	.83
2.00	.0180	24.0	175.0	.811	0.0	.77
3.25	.0180	24.0	175.0	.499	0.0	.47
2.75	.0175	30.0	150.0	.713	0.0	.76
2.75	.0150	42.0	150.0	.901	0.0	.92
2.75	.0130	42.0	150.0	.754	0.0	.81
2.25	.0110	28.0	125.0	.685	0.0	.67
4.25	.0160	48.0	125.0	.863	0.0	.82
3.85	.0182	25.0	125.0	.502	0.0	.55
3.95	.0115	45.0	120.0	.625	0.0	.64
3.35	.0126	35.0	100.0	.802	0.0	.75
3.35	.0126	25.0	100.0	.547	0.0	.54
2.95	.0095	50.0	110.0	.871	0.0	.87
2.55	.0015	30.0	105.0	.689	0.0	.70

TABLE A 5.2.2 RESULTS OF SIMULATION ON LEVEL BASINS
I = 0.5 Family

D_u (In)	q (cfs/ft)	T (Min)	L (ft)	E_r	D_r	E_r From Formula
3.75	.019	100.0	350.0	.953	0.013	.97
3.00	.022	55.0	300.0	.903	.001	.89
2.90	.0195	55.0	260.0	.943	.008	.93
2.50	.0190	35.0	250.0	.751	.000	.72
3.50	.025	96.0	500.0	.932	.0017	.95
2.00	.018	28.0	175.0	.930	.01	.92
3.25	.018	28.0	175.0	.579	.00	.58
2.75	.0175	36.0	150.0	.903	.00	.94
2.75	.015	44.0	150.0	.996	.038	.99
2.75	.013	44.0	150.0	.889	.00	.88
2.25	.011	28.0	125.0	.726	.00	.71
4.25	.016	48.0	125.0	.963	.00	.86
3.85	.0182	32.0	125.0	.696	.00	.73
3.95	.0115	48.0	120.0	.712	.00	.72
3.35	.0126	44.0	100.0	.989	.007	.97
3.35	.0126	36.0	100.0	.787	.00	.81
2.95	.0095	56.0	110.0	.996	.053	1.00
2.55	.0205	40.0	105.0	.955	.003	.96

TABLE A 5.2.3 RESULTS OF SIMULATION ON LEVEL BASINS
I = 1.0 Family

D_u (In)	q (cfs/ft)	T (Min)	L (ft)	E_r	D_r	E_r From Formula
3.75	.019	120.0	350.0	.984	.071	.95
3.00	.022	70.0	300.0	.991	.146	.96
2.90	.0195	75.0	260.0	.979	.218	1.04
2.50	.019	50.0	250.0	.955	.098	.93
3.50	.025	108.0	500.0	.919	.156	.88
2.00	.018	27.0	175.0	.903	.055	.92
3.25	.018	27.0	175.0	.588	.000	.62
2.75	.0175	30.0	150.0	.845	.000	.81
2.75	.0150	36.0	150.0	.880	.001	.84
2.75	.0130	36.0	150.0	.793	.000	.78
2.25	.011	33.0	125.0	.872	.012	.89
4.25	.016	33.0	125.0	.625	.000	.64
3.85	.0182	28.0	125.0	.653	.000	.66
3.95	.0115	45.0	120.0	.657	.000	.71
3.85	.0182	32.0	1256.0	.738	.000	.72
3.35	.0126	36.0	100.0	.873	.000	.81
2.95	.0095	54.0	110.0	.983	.058	.95
2.55	.0105	45.0	105.0	.989	.152	1.03

TABLE A 5.2.4 RESULTS OF SIMULATION ON LEVEL BASINS
I = 1.0 Family

D_u (In)	q (cfs/ft)	T (Min)	L (ft)	E_r	D_r	E_r From Formula
3.75	0.019	120.0	350.0	.930	.238	.92
3.00	0.022	70.0	300.0	.952	.206	.91
2.90	.0195	90.0	160.0	.992	.355	1.03
2.50	.019	60.0	150.0	.952	.250	.96
3.50	.025	170.0	500.0	.977	.425	1.01
2.00	.018	35.0	175.0	.954	.216	.97
3.25	.018	35.0	175.0	.749	.00	.78
2.75	.0175	36.0	150.0	.925	.057	.89
2.75	.0150	44.0	150.0	.976	.093	.92
2.75	.0130	44.0	150.0	.898	.051	.89
2.25	.0110	39.0	125.0	.937	.107	.96
4.25	.0160	39.0	125.0	.743	.00	.79
3.85	.0196	30.0	125.0	.772	.00	.78
3.95	.0115	54.0	120.0	.858	.00	.86
3.65	.0115	54.0	120.0	.917	.013	.89
3.35	.0126	48.0	100.0	.994	.155	.96
2.95	.0095	03.0	110.0	.987	.194	1.01
2.55	.0105	51.0	105.0	.998	.226	1.04

TABLE A 5.2.5
RESULTS OF REGRESSION FOR REQUIREMENT EFFICIENCY
OF LEVEL BASIN IRRIGATION

Infiltration Family	Relationship			Coefficient of Correlation
0.10	186.21	$q = .898 T - .962 / D_u + 1.02 L - .819$		0.95
0.50	147.91	$q = .837 T - .899 / D_u + .955 L - .784$		0.95
1.00	22.91	$q = .468 T - .586 / D_u + .800 L - .526$		0.93
1.50	4.96	$q = .222 T - .348 / D_u + .442 L - .323$		0.87

APPENDIX 6.1

HEAD VARIATION UNDER MAIN CANALS

APPENDIX A 6.1

HEAD VARIATIONS UNDER THE MAIN CANALS

Using the approach given in section 6.5, the variations of mean head values over time for the groundwater table under the main canals studied are given below:

SYSTEM	SOIL GROUP NUMBER	HEAD VARIATION* (above datum)
1	1	$h = 120 + 2.83 t^{.72}$
1	2	$h = 100 + 4.63 t^{.59}$
1	3	$h = 80 + 4.38 t^{.61}$
1	4	$h = 60 + 3.42 t^{.65}$
2	1	$h = 110 + 2.51 t^{.73}$
2	2	$h = 100 + 4.11 t^{.59}$
2	2'	$h = 70 + 2.57 t^{.72}$

* h is in feet and t is in years.