

THESIS

GENERALIZED PERSISTENCE FOR DISCRETE DYNAMICAL SYSTEMS

Submitted by

Jacob Cleveland

Department of Mathematics

In partial fulfillment of the requirements

For the Degree of Master of Science

Colorado State University

Fort Collins, Colorado

Spring 2025

Master's Committee:

Advisor: Amit Patel

Emily King

Mark Dineen

Copyright by Jacob A. Cleveland 2025

All Rights Reserved

## ABSTRACT

### GENERALIZED PERSISTENCE FOR DISCRETE DYNAMICAL SYSTEMS

We introduce a novel method for extracting persistent topological descriptions of discrete dynamical systems from finite samples in the form of generalized persistence diagrams. These persistence diagrams are decorated with eigenvalues of linear maps associated to a certain local system called the *persistent local system*. We also prove the stability of our method and provide an example of recovering the induced map on homology from a finite sample.

## ACKNOWLEDGEMENTS

I would like to thank my advisor Amit Patel for inviting me along this journey through persistent local system and generalized persistence. In performing this project, I have learned more than I ever thought possible. I thank Alan Hylton, Bob Short, Robby Green, Billy Bernardoni, Justin Curry, Brendan Mallory, Olivia Freides, Zander Memon, Michael Moy, and all the other wonderful interns, professors, engineers, and scientists I had the pleasure of working with during my time at NASA GRC. You were all monumental in showing me the power of mathematics to solve interesting engineering problems. I would like to thank Griff Elder for inspiring me to pursue mathematics as a career in the first place. You showed me that mathematics can be beautiful. You do amazing work recruiting future mathematicians of all backgrounds and should be very proud of your legacy. I would like to thank Bryan Elder for making the graduate student experience at CSU a success. I would like to thank my fellow graduate students at CSU for countless hours of collaboration. Talking about mathematics is what makes it doable. I would like to thank my students in the various classes I've had the opportunity to teach over the years at CSU. It has been a joy watching you all grow as you expand your calculus knowledge. Last, but not least, I would like to thank all of my friends and family for being supportive through every step of grad school.

## DEDICATION

*I would like to dedicate this thesis to my uncle Nathan Bonewitz. You had a beautiful mind and I miss you dearly.*

## TABLE OF CONTENTS

	ABSTRACT . . . . .	ii
	ACKNOWLEDGEMENTS . . . . .	iii
	DEDICATION . . . . .	iv
Chapter 1	Introduction . . . . .	1
1.1	Our work . . . . .	1
1.2	Related Literature . . . . .	2
Chapter 2	The Adjunction Space of a Correspondence . . . . .	3
2.1	The Self-Correspondence of Cell Complexes . . . . .	3
2.2	An Adjunction Space For Correspondences . . . . .	5
2.3	The Basepoint Constructible Map . . . . .	7
Chapter 3	Bisheaves and Persistent Local Systems for $(\mathbb{S}^1, *)$ . . . . .	11
3.1	Sheaves over $(\mathbb{S}^1, *)$ . . . . .	11
3.2	Coheaves under $(\mathbb{S}^1, *)$ . . . . .	13
3.3	Bisheaves around $(\mathbb{S}^1, *)$ . . . . .	14
3.4	The Persistent Local System Over $\mathbb{S}^1$ in Degree $d$ . . . . .	17
Chapter 4	The Grothendieck Group of $\text{Loc}(\mathbb{S}^1, \text{Vec})$ . . . . .	20
Chapter 5	Generalized Persistence for local systems over the circle. . . . .	24
5.1	Constructible Persistence Modules of Persistent Local Systems over $\mathbb{S}^1$ . . . . .	24
5.2	The Rank Invariant of a Persistence Module of Local Systems . . . . .	25
5.3	Generalized Persistence Diagrams . . . . .	26
5.4	Stability of Generalized Persistence Diagrams . . . . .	28
Chapter 6	The Pipeline . . . . .	31
6.1	General Description . . . . .	31
6.2	A Computational Example . . . . .	36
	Bibliography . . . . .	39

# Chapter 1

## Introduction

Given a discrete dynamical system, i.e., a metric space  $(M, d)$  together with a continuous self-map  $\varphi : M \rightarrow M$ , one would like to learn the induced map on homology  $H_\bullet(\varphi) : H_\bullet(M) \rightarrow H_\bullet(M)$  using only information from a finite sample  $X \subseteq M$ .

One way to extract this information would be to try and apply *classical persistent homology*. However, there are two problems with this approach:

1.  $H_\bullet(\varphi)$  is an endomorphism of vector spaces, so we could analyze a persistence module of endomorphisms of vector spaces. However, *classical* persistence is only deals with persistence modules of vector spaces.
2. Restricting the map  $\varphi$  to  $X_r$  yields maps  $\varphi_r : X_r \rightarrow X_r$ , but these are generally not simplicial. If the  $\varphi_r$  were simplicial, then  $H_\bullet(\varphi_r)$  would yield a persistence module of endomorphisms. Then we could analyze this persistence module using *generalized* persistence.

### 1.1 Our work

Given a finite sample  $X \subseteq M$  of a discrete dynamical system  $(M, d, \varphi)$ , we create a filtration of Vietoris-Rips complexes  $\{X_r\}$  (see Definition 6.1.2). From each VR-complex, there is a natural space with a map to the circle which captures how simplices move in the dynamical system (Section 2). Using this map to the circle, we extract an endomorphism on degree  $d$  homology with  $\mathbb{C}$  coefficients (Section 3). Repeating this construction for each VR-complex in the filtration  $\{X_r\}$  yields a collection of endomorphisms on degree  $d$  homology which can be analyzed using *generalized* persistence (Sections 4 and 5). Lastly, we show this pipeline is stable and give an example where the induced map is recovered (Section 6).

## 1.2 Related Literature

Persistence has been applied to structural questions about continuous dynamical systems such as the detection of bifurcations in continuous dynamical systems [1–3]. Some authors have also studied classical topological invariants of time series using time delay embeddings [4, 5]. Other authors have analyzed the shape of time series for a dynamical system using persistent homology [6–8]. The problem we are interested in is different because we will extract endomorphisms on degree  $d$  homology in addition to the degree  $d$  homology  $H_d(M)$  for a discrete dynamical system.

Edelsbrunner et. al. describe a method for extracting the eigenvalues of the induced map on homology  $H_\bullet(\varphi) : H_\bullet(M) \rightarrow H_\bullet(M)$  from a finite sample  $X \subseteq M$  [9]. To accomplish this, they introduce the concept of a *tower of eigenspaces of a pair of maps* and develop a persistence approach to extract persistence diagrams from these. From the finite sample  $X \subseteq M$ , they create a filtration of VR-complexes  $\{X_r\}$  and restrict to a filtration of subcomplexes  $A_r \subseteq X_r$  such that  $\varphi$  induces simplicial maps  $\varphi_r : A_r \rightarrow A_r$ . Applying homology to these filtrations yields two towers of vector spaces. Fixing an eigenvalue, they then compute a tower of eigenspaces from each pair of linear maps from the pair of towers of vector spaces. Lastly, they compute the associated persistence diagram, which allows them to approximate the eigenvalues of the induced map on homology. Note the method described by Edelsbrunner et. al. uses the same input as our method.

# Chapter 2

## The Adjunction Space of a Correspondence

### 2.1 The Self-Correspondence of Cell Complexes

In this section, we construct a self-correspondence for a simplicial complex which we will use to track homological features that survive application of the dynamical system map. In order to accomplish this, we need our self-correspondence to be a relatively nice space so that the process is computationally tractable. We begin by defining the notion of a cell complex, which is a combinatorial description of certain topological spaces that can be built up from closed Euclidean  $n$ -disks.

**Definition 2.1.1.** A *cell complex* is a CW complex,  $X$ , where each closed cell of  $X$  is homeomorphic to a closed Euclidean  $n$ -disk.

Given a cell complex  $X$ , there is a face poset  $\mathcal{F}(X)$  consisting of the set of closed cells together with face relation  $\trianglelefteq$  given by containment [ [10]].

**Definition 2.1.2.** Let  $X$  be a cell complex and  $\{A_\alpha\}$  be a collection of closed cells of  $X$ . Then define the *closure* of  $\{A_\alpha\}$ , denoted  $\overline{\{A_\alpha\}}$ , whose face poset is

$$\mathcal{F}\left(\overline{\{A_\alpha\}}\right) = \{\sigma \in \mathcal{F}(X) : \sigma \trianglelefteq A_\alpha\}$$

Note that in the definition of above, the closure  $\overline{\{A_\alpha\}}$  is a subcomplex of  $X$ .

**Definition 2.1.3.** Let  $X$  and  $Y$  be cell complexes. The  *$n$ -skeleton*  $X^n$  of  $X$  is the subcomplex of  $X$  containing cells of dimension at most  $n$ . A function  $f : X \rightarrow Y$  is called *cellular* if  $f(X^n) \subseteq Y^n$  for all  $n \geq 0$ .

Denote by  $\text{Cell}$  the category of cell complexes together with cellular maps. We will also choose to view simplicial complexes as cell complexes when convenient.

**Proposition 2.1.4.** Let  $X$  and  $Y$  be cell complexes. Then  $X \times Y$  is a cell complex and the associated projection maps  $\pi_1$  and  $\pi_2$  are cellular.

*Proof.* Suppose  $\sigma \in \mathcal{F}(X)$  and  $\tau \in \mathcal{F}(Y)$  are closed cells of  $X$  and  $Y$  respectively. If  $\sigma$  is homeomorphic to an  $n$ -disk and  $\tau$  is homeomorphic to an  $m$ -disk, then  $\sigma \times \tau$  is a closed cell homeomorphic to an  $n + m$ -disk. Since this is true of all closed cells  $\sigma$  and  $\tau$ ,  $X \times Y$  is a cell complex consisting of the appropriate closed cells.

Further note that  $\pi_1(\sigma \times \tau)$  is an  $n$  cell and  $\pi_2(\sigma \times \tau)$  is an  $m$  cell, so  $\pi_1((X \times Y)^{n+m}) \subseteq X^n$  and  $\pi_2((X \times Y)^{n+m}) \subseteq Y^m$ . Hence  $\pi_1$  and  $\pi_2$  are cellular.  $\square$

**Definition 2.1.5.** A (self) correspondence  $C$  of a cell complex  $X$  is a subcomplex of the product  $X \times X$  in Cell.

Since  $C$  includes into  $X \times X$ ,  $C$  has its own projection maps  $\tilde{\pi}_1$  and  $\tilde{\pi}_2$  which come from restricting  $\pi_1$  and  $\pi_2$ . For a self-correspondence  $C$  of  $X$ , we have the following commutative diagram of cell complexes, where all morphisms are cellular:

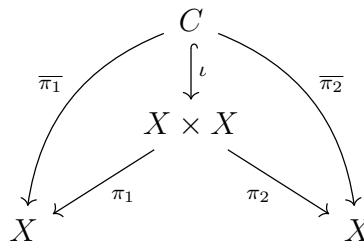

In a simplicial complex, each cell is a simplex and hence can be uniquely identified by its vertices. This allows us to track where cells are mapped under  $\varphi$  by looking at the image of a cell's vertices. However, because a single cell can be broken up and sent to multiple cells, we cannot capture where cells go using a function. Instead, we define a special type of correspondence to track what cells correspond to what other cells.

For the rest of section 2, fix  $\{x_i\}$  to be some fixed vertex set and fix some map  $\varphi : \{x_i\} \rightarrow \{x_i\}$ .

**Definition 2.1.6.** If  $\{x_i\}$  is a multiset of vertices, define  $\Delta\{x_i\}$  to be the maximal simplex on the vertices  $\{x_i\}$ .

**Definition 2.1.7.** Let  $K$  be a simplicial complex with vertices  $\{x_i\}$  and  $\varphi : \{x_i\} \rightarrow \{x_i\}$  be a map on the vertices. Define  $\varphi' : K \rightarrow 2^K$  to be the map which sends an  $n$ -simplex  $[v_1, \dots, v_n]$  to the subcomplex of  $K$  consisting of all faces  $\Delta\{\varphi(v_1), \dots, \varphi(v_n)\}$  such that the faces are also in  $K$ ,

$$\varphi'([v_1, \dots, v_n]) := \{\tau \in K \mid \tau \trianglelefteq \Delta\{\varphi(v_1), \dots, \varphi(v_n)\}\}$$

Note that  $\{\varphi(v_1), \dots, \varphi(v_n)\}$  is in general a multiset because some of the elements may repeat. Also note that  $\Delta\{\varphi(v_1), \dots, \varphi(v_n)\}$  is not necessarily a simplex in  $K$ .

**Definition 2.1.8.** Using the same setup as above, define the correspondence  $C_\varphi(K) \subseteq K \times K$  to be the cell complex

$$C_\varphi(K) := \overline{\{\sigma \times \tau \mid \sigma \in K, \tau \in \varphi'(\sigma)\}}$$

Note that if  $\sigma_1 \trianglelefteq \sigma_2$  and  $\tau_1 \trianglelefteq \tau_2$  then  $(\sigma_1 \times \tau_1) \trianglelefteq (\sigma_2 \times \tau_2)$ . Let  $K \subseteq L$  be simplicial complexes with vertices  $\{x_i\}$ . Then for  $\sigma \times \tau \in C_\varphi(K)$ ,  $\sigma \times \tau \in C_\varphi(L)$  because  $\varphi'(\sigma) \subseteq L$ , hence we have an inclusion map  $C_\varphi(K) \hookrightarrow C_\varphi(L)$ . This yields the commutative diagram in Figure 2.1.

$$\begin{array}{ccc} K \times K & \hookrightarrow & L \times L \\ \uparrow & & \uparrow \\ C_\varphi(K) & \hookrightarrow & C_\varphi(L) \end{array}$$

**Figure 2.1:** Induced inclusion on correspondences

## 2.2 An Adjunction Space For Correspondences

**Definition 2.2.1.** Let  $X$  and  $Y$  be cell complexes with  $A \subseteq X$  a subcomplex and  $f : A \rightarrow Y$  a cellular map. Define the adjunction space  $X \cup_f Y$  to be the pushout of the diagram consisting of  $A \subseteq X$  and  $f : A \rightarrow Y$  as in Figure 2.2.

**Proposition 2.2.2.** The adjunction space of cell complexes  $X \cup_f Y$  is a cell complex.

$$\begin{array}{ccc}
A & \xrightarrow{\iota} & X \\
f \downarrow & & \downarrow \varphi_X \\
Y & \xrightarrow{\varphi_Y} & X \cup_f Y
\end{array}$$

**Figure 2.2:** The adjunction of two cell complexes

*Proof.* Indeed, because  $A$  is a subcomplex, we can define  $\mathcal{F}(X \cup_f Y) := \mathcal{F}(X - A) \cup \mathcal{F}(Y)$ . Let  $\sigma \in \mathcal{F}(X \cup_f Y)$  be a closed cell. Further, since  $f$  is cellular, we can express  $\sigma = \alpha \cup \beta$  where  $\alpha \in \mathcal{F}(X - A)$  and  $\beta \in \mathcal{F}(Y)$  are both closed cells. Since  $X$  and  $Y$  are both cell complexes,  $\alpha$  is homeomorphic to some closed  $n$ -disk and  $\beta$  is homeomorphic to some closed  $m$ -disk. Therefore the homeomorphisms can be combined to see that  $\sigma$  is homeomorphic to a closed  $(\max\{m, n\})$ -disk.  $\square$

**Definition 2.2.3.** Let  $f : A_1 \rightarrow Y$  and  $g : A_2 \rightarrow Y$  be a pair of cellular maps and  $A_1, A_2 \subseteq X$  subcomplexes of cell complex  $X$  where  $A_1 \cap A_2 = \emptyset$ . Define  $f \cup g : A_1 \cup A_2 \rightarrow Y$  as

$$(f \cup g)(x) = \begin{cases} f(x), & x \in A_1 \\ g(x), & x \in A_2 \end{cases}$$

The next space we define is the space which we will use to detect homological features that persist through applications of the dynamical system map  $\varphi$ .

$$\begin{array}{ccc}
& \xrightarrow{\rho_0} & \\
C_\varphi(K) \times [0, 2\pi] & \xrightarrow{\quad} & C_\varphi(K) \\
& \xleftarrow{\rho_{2\pi}} & \\
& & \xrightarrow{\iota} K \times K \\
& & \begin{array}{ccc} \xrightarrow{\pi_1} & & K \\ \xleftarrow{\pi_2} & & \end{array}
\end{array}$$

**Figure 2.3:** Maps for defining the ouroboros space  $\mathcal{O}_\varphi(K)$

**Definition 2.2.4.** Let  $K$  be a simplicial complex with correspondence  $C_\varphi(K)$  and  $\kappa_1 := \pi_1 \circ \iota \circ \rho_0$  and  $\kappa_2 := \pi_2 \circ \iota \circ \rho_{2\pi}$  as in Figure 2.3. Define the *ouroboros space* of  $K$  to be the following

$$\begin{array}{ccc}
C_\varphi(K) \times \{\{0\}, \{2\pi\}\} & \xrightarrow{\iota} & C_\varphi(K) \times [0, 2\pi] \\
\kappa_1 \cup \kappa_2 \downarrow & & \downarrow \Phi \\
K & \xrightarrow{\Psi} & \mathcal{O}_\varphi(K)
\end{array}$$

**Figure 2.4:** The ouroboros space  $\mathcal{O}_\varphi(K)$  as an adjunction in Cell

adjunction (see Figure 2.4) in Cell:

$$\mathcal{O}_\varphi(K) := (C_\varphi(K) \times [0, 2\pi]) \bigcup_{\kappa_1 \cup \kappa_2} K$$

The fact that  $\mathcal{O}_\varphi(K)$  is a cell complex follows from propositions 2.1.4 and 2.2.2 since  $C_\varphi(K)$ ,  $[0, 2\pi]$ , and  $K$  are all cell complexes, and  $\kappa_1$  and  $\kappa_2$  are cellular. Note that we can view  $\mathcal{O}_\varphi(K)$  with coordinates  $(c, \theta)$  where  $c \in C_\varphi(K)$  is a point in the cell complex and  $\theta \in [0, 2\pi]$ .

## 2.3 The Basepoint Constructible Map

In this section, we define a basis for the usual topology on the circle that allows us to view the pointed circle  $(\mathbb{S}^1, *)$  as a *stratified space* as in [11]. We are interested in this particular basis because it allows us to define a constructible map (see Definition 2.3.3) from the ouroboros space  $\mathcal{O}_\varphi(K)$  to  $(\mathbb{S}^1, *)$  which we will use to study a dynamical system.

**Definition 2.3.1.** Define  $\mathbb{S}^1 = [0, 2\pi]/\sim$  to be the circle where  $0 \sim 2\pi$ . Further define  $(\mathbb{S}^1, *)$  to be the *pointed circle* where the basepoint  $* = 0 \sim 2\pi$  as in Figure 2.5.

**Definition 2.3.2.** Define the basis  $\mathcal{B}$  for the topology on  $(\mathbb{S}^1, *)$  as follows:

$$\mathcal{B} = \{(a, b) \mid 0 < a < b < 2\pi\} \cup \{[0, a) \cup (b, 2\pi] \mid 0 < a < b < 2\pi\}.$$

The basis elements of the form  $(a, b)$  are referred to as *type I* open sets and the basis elements of the form  $[0, a) \cup (b, 2\pi]$  are referred to as *type II* open sets. Examples of each type of open set are shown in Figure 2.5.

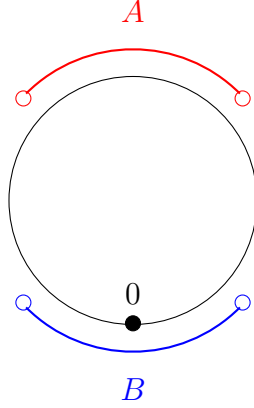

**Figure 2.5:** Pointed circle  $(\mathbb{S}^1, *)$  with type I open set,  $A \in \mathcal{B}$ , and type II open set,  $B \in \mathcal{B}$ , shown

**Definition 2.3.3.** Let  $\mathbb{X}$  be a Hausdorff, locally compact, and second countable topological space. A continuous map  $f : \mathbb{X} \rightarrow \mathbb{S}^1$  is  $(\mathbb{S}^1, *)$ -*constructible* (or just *constructible*) if for all  $V \subseteq U \in \mathcal{B}$  of the same type, the inclusions

$$(\mathbb{X}, \mathbb{X} - f^{-1}(U)) \hookrightarrow (\mathbb{X}, \mathbb{X} - f^{-1}(V)) \qquad f^{-1}(V) \hookrightarrow f^{-1}(U)$$

are homotopy equivalences.

**Definition 2.3.4.** Given a simplicial complex  $K$  with vertices  $\{x_i\}$ , define the map

$$\begin{aligned} f : \mathcal{O}_\varphi(K) &\rightarrow \mathbb{S}^1 \\ (c, \theta) &\mapsto \theta \end{aligned}$$

To see that the map is well-defined, consider  $(c_1, 0) \sim (c_2, 2\pi) \in \mathcal{O}_\varphi(K)$  where  $c_1 \neq c_2$ . Then  $f(c_1, 0) = 0 \sim 2\pi = f(c_2, 2\pi)$ . So, this is a well-defined map to the circle  $\mathbb{S}^1$ .

**Proposition 2.3.5.** The map defined in Definition 2.3.4 is constructible.

*Proof.* First observe that  $\mathcal{O}_\varphi(K)$  is a cell complex, and cell complexes are Hausdorff, locally compact, and second countable topological spaces. Let  $V \subseteq U \in \mathcal{B}$  be the same type. The fact that both  $(\mathcal{O}_\varphi(K), \mathcal{O}_\varphi(K) - f^{-1}(U)) \hookrightarrow (\mathcal{O}_\varphi(K), \mathcal{O}_\varphi(K) - f^{-1}(V))$  and  $f^{-1}(V) \hookrightarrow f^{-1}(U)$  are

homotopy equivalences follows using straightline homotopies for the diagram in Figure 2.6 since  $f^{-1}(U)$  is path connected for any type I open set  $U \in \mathcal{B}$ .  $\square$

$$\begin{array}{ccc}
 C_\varphi(K) \times f^{-1}(V) & \xrightarrow{\bar{\iota}} & C_\varphi(K) \times f^{-1}(U) \\
 \downarrow f \circ \pi_2 & & \downarrow f \circ \pi_2 \\
 V & \xrightarrow{\iota} & U
 \end{array}$$

**Figure 2.6:** Commutative diagram for showing the map in Definition 2.3.3 is constructible

**Definition 2.3.6.** Let  $\text{Con}(\mathbb{S}^1, *)$  be the category where the objects are  $(\mathbb{S}^1, *)$ -constructible maps, and a morphism  $c : f \rightarrow g$  is a continuous map  $c : \mathbb{X} \rightarrow \mathbb{Y}$  such that  $f = g \circ c$ , i.e., a map which makes the triangle in Figure 2.7 commute.

$$\begin{array}{ccc}
 \mathbb{X} & \xrightarrow{c} & \mathbb{Y} \\
 & \searrow f & \swarrow g \\
 & \mathbb{S}^1 &
 \end{array}$$

**Figure 2.7:** Commutative diagram for a morphism  $c : f \rightarrow g$

Define  $(\text{Simp}_{\{x_i\}}, \subseteq)$  to be the poset category of simplicial complexes on a fixed vertex set  $\{x_i\}$  with a fixed map  $\varphi : \{x_i\} \rightarrow \{x_i\}$  where the morphisms are given by inclusion maps. Note that if  $\iota : K \rightarrow L$  is a morphism in  $(\text{Simp}_{\{x_i\}}, \subseteq)$ , then there is an induced inclusion on correspondences  $\bar{\iota} : C_\varphi(K) \hookrightarrow C_\varphi(L)$  as in Figure 2.1. Note these inclusions can be extended to an inclusion on ouroboros spaces  $\tilde{\iota} : \mathcal{O}_\varphi(K) \rightarrow \mathcal{O}_\varphi(L)$  since there are inclusions (namely  $\iota$ ,  $\bar{\iota}_1$ , and  $\bar{\iota}_2$ ) between the components of the pushout diagrams for  $\mathcal{O}_\varphi(K)$  and  $\mathcal{O}_\varphi(L)$  as in Figure 2.8.

**Definition 2.3.7.** Let  $\iota : K \rightarrow L$  be a morphism in  $(\text{Simp}_{\{x_i\}}, \subseteq)$ . Then we have an induced inclusion of ouroboros spaces  $\tilde{\iota} : \mathcal{O}_\varphi(K) \rightarrow \mathcal{O}_\varphi(L)$ . Define the constructible adjunction space

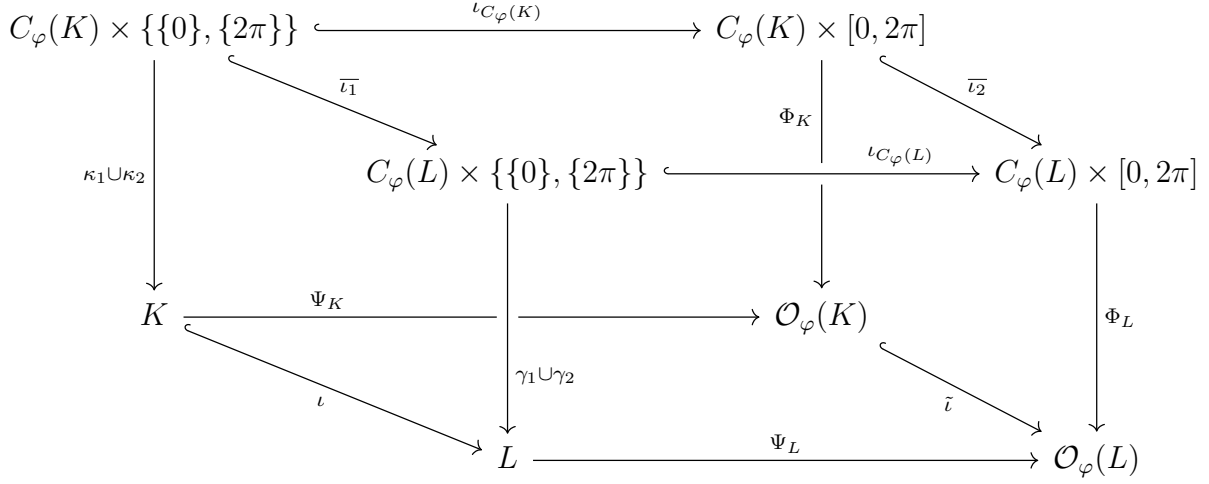

**Figure 2.8:** Induced inclusion on ouroboros spaces

functor  $\text{adj}_\varphi : (\text{Simp}_{\{x_i\}}, \subseteq) \rightarrow \text{Con}(\mathbb{S}^1, *)$  as

$$\text{adj}_\varphi(K) : \mathcal{O}_\varphi(K) \rightarrow \mathbb{S}^1$$

$$(c, \theta) \mapsto \theta$$

$$\text{adj}_\varphi(\iota) : \mathcal{O}_\varphi(K) \rightarrow \mathcal{O}_\varphi(L)$$

$$(c, \theta) \mapsto (\iota(c), \theta)$$

## Chapter 3

### Bisheaves and Persistent Local Systems for $(\mathbb{S}^1, *)$ .

We are now interested in studying certain constructable functors for topological spaces valued in  $\text{Vec}$ , the category of finite dimensional  $\mathbb{C}$ -vector spaces. These functors will allow us to define the persistent local system in degree  $d$  (Section 3.4), which will be the setting in which we are able to algebraically determine what generators of degree  $d$  homology survive the map  $\varphi$ .

**Definition 3.0.1.** Let  $\mathbb{X}$  be a topological space. An open cover  $\mathcal{U}$  of  $\mathbb{X}$  is a collection of open subsets  $\{U_i\}_i$  such that  $U_i \cap U_j \in \mathcal{U}$  for all  $U_i, U_j$  and  $\mathbb{X} = \bigcup_i U_i$ .

#### 3.1 Sheaves over $(\mathbb{S}^1, *)$

**Definition 3.1.1.** Let  $\mathbb{X}$  be a topological space with poset category of open subsets  $\text{Open}(\mathbb{X})$  and let  $\text{Vec}$  be the category of finite dimensional  $\mathbb{C}$ -vector spaces. A *sheaf* over  $\mathbb{X}$  valued in  $\text{Vec}$  is a contravariant functor

$$\bar{F} : \text{Open}(\mathbb{X}) \rightarrow \text{Vec}$$

such that for all open sets  $U \subseteq \mathbb{X}$  and all open covers  $\mathcal{U}$  of  $U$ , the universal arrow

$u : \bar{F}(U) \rightarrow \lim_{\mathcal{U}} \bar{F}|_{\mathcal{U}}$  is an isomorphism. The maps  $\bar{F}(V \subseteq U) : \bar{F}(U) \rightarrow \bar{F}(V)$  are called *restriction maps*.

**Definition 3.1.2.** A sheaf over  $\mathbb{S}^1$  valued in  $\text{Vec}$  is  $(\mathbb{S}^1, *)$ -*constructible* (or just *constructible*) if for every pair of basis elements  $V \subseteq U \in \mathcal{B}$  of the same type,  $\bar{F}(V \subseteq U) : \bar{F}(U) \rightarrow \bar{F}(V)$  is an isomorphism. If  $\bar{F}(V \subseteq U) : \bar{F}(U) \rightarrow \bar{F}(V)$  is also an isomorphism for all pairs  $V \subseteq U \in \mathcal{B}$ , then  $\bar{F}$  is a *local system*.

The collection of local systems over  $\mathbb{S}^1$  valued in  $\text{Vec}$  together with natural transformations between them forms a category denoted  $\text{Loc}(\mathbb{S}^1)$ .

**Definition 3.1.3.** An  $(\mathbb{S}^1, *)$ -constructible sheaf  $\bar{E}$  over  $\mathbb{S}^1$  is an *episheaf* over  $\mathbb{S}^1$  if for every pair of basis elements  $V \subseteq U \in \mathcal{B}$ , the map  $\bar{E}(V \subseteq U) : \bar{E}(U) \rightarrow \bar{E}(V)$  is surjective.

**Definition 3.1.4.** A *sheaf map*  $\bar{\alpha} : \bar{F} \rightarrow \bar{G}$  is a natural transformation of functors. If  $\bar{F}$  is a  $(\mathbb{S}^1, *)$ -constructible sheaf, then a *sub-episheaf* of  $\bar{F}$  is an injective sheaf map  $\bar{\alpha} : \bar{F} \hookrightarrow \bar{E}$  to an episheaf  $\bar{E}$  over  $\mathbb{S}^1$ . Further, the *epification*  $\text{Epi}(\bar{F})$  is the maximal sub-episheaf of  $\bar{F}$ , where the maximum is taken over all images of sub-episheaves of  $\bar{F}$  ordered by inclusion. See Figure 3.1.

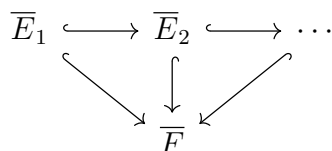

**Figure 3.1:** Diagram for epification of a sheaf  $\bar{F}$

**Theorem 3.1.5.** An  $(\mathbb{S}^1, *)$ -constructible sheaf over  $(\mathbb{S}^1, *)$  is equivalent to a pair of vector spaces  $\mathbb{C}^n, \mathbb{C}^m$  together with linear maps  $a, b : \mathbb{C}^n \rightarrow \mathbb{C}^m$ .

*Proof.* Indeed, by the definition of an  $(\mathbb{S}^1, *)$ -constructible sheaf, we have one isomorphism class of  $\mathbb{C}$ -vector spaces over any type I open set and another isomorphism class of  $\mathbb{C}$ -vector spaces over any type II open set. The maps  $a$  and  $b$  are therefore given (up to isomorphism) by the restriction maps from a type II open set  $V$  to two type I open sets  $U, W \subseteq V$ , one on either side of the basepoint, as in Figure 3.2. □

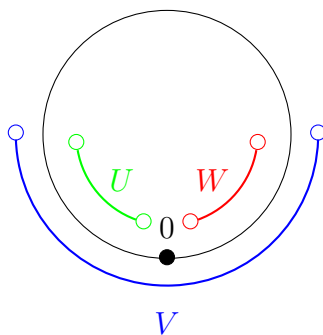

**Figure 3.2:** Example type II open set  $V$  and type I open sets  $U, W$  used in Theorem 3.1.5 for constructing a simpler algebraic structure from a  $(\mathbb{S}^1, *)$ -constructible sheaf

## 3.2 Coheaves under $(\mathbb{S}^1, *)$

**Definition 3.2.1.** A *cosheaf* under  $\mathbb{X}$  valued in  $\text{Vec}$  is a covariant functor

$$\underline{F} : \text{Open}(\mathbb{X}) \rightarrow \text{Vec}$$

such that for all open sets  $U \subseteq \mathbb{X}$  and all open covers  $\mathcal{U}$  of  $U$ , the universal arrow

$u : \text{colim}_{\mathcal{U}} \underline{F} \rightarrow \underline{F}(U)$  is an isomorphism. The maps  $\underline{F}(V \subseteq U) : \underline{F}(V) \rightarrow \underline{F}(U)$  are called *extension maps*.

**Definition 3.2.2.** A cosheaf under  $\mathbb{S}^1$  valued in  $\text{Vec}$  is  $(\mathbb{S}^1, *)$ -*constructible* (or just *constructible*) if for every pair of basis elements  $V \subseteq U \in \mathcal{B}$  of the same type,  $\underline{F}(V \subseteq U) : \underline{F}(V) \rightarrow \underline{F}(U)$  is an isomorphism. If  $\underline{F}(V \subseteq U) : \underline{F}(U) \rightarrow \underline{F}(V)$  is also an isomorphism for all  $V \subseteq U \in \mathcal{B}$ , then  $\underline{F}$  is a *colocal system*.

The collection of colocal systems under  $\mathbb{S}^1$  valued in  $\text{Vec}$  together with natural transformations between them forms a category denoted  $\text{Coloc}(\mathbb{S}^1)$ .

**Definition 3.2.3.** An  $(\mathbb{S}^1, *)$ -constructible cosheaf  $\underline{M}$  over  $\mathbb{S}^1$  is a *monocosheaf* under  $\mathbb{S}^1$  if for every pair  $V \subseteq U \in \mathcal{B}$ , the map  $\underline{M}(V \subseteq U) : \underline{M}(U) \rightarrow \underline{M}(V)$  is injective.

**Definition 3.2.4.** A *cosheaf map*  $\underline{\alpha} : \underline{F} \rightarrow \underline{G}$  is a natural transformation of functors. If  $\underline{F}$  is a  $(\mathbb{S}^1, *)$ -constructible cosheaf, then a *quotient-monocosheaf* of  $\underline{F}$  is a surjective cosheaf map  $\underline{\alpha} : \underline{F} \rightarrow \underline{M}$  to a monocosheaf  $\underline{M}$  under  $\mathbb{S}^1$ . Further, the *monofication*  $\text{Mon}(\underline{F})$  is the minimal quotient monocosheaf of  $\underline{F}$ , where the minimum is taken over all kernels of quotient monocosheaves of  $\underline{F}$  ordered by inclusion. See Figure 3.3.

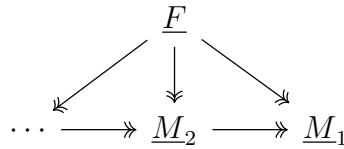

**Figure 3.3:** Diagram for monofication of a cosheaf  $\underline{F}$

**Theorem 3.2.5.** An  $(\mathbb{S}^1, *)$ -constructible cosheaf under  $(\mathbb{S}^1, *)$  is equivalent to a pair of vector spaces  $\mathbb{C}^m, \mathbb{C}^n$  together with linear maps  $a, b : \mathbb{C}^m \rightarrow \mathbb{C}^n$ .

*Proof.* Indeed, by the definition of an  $(\mathbb{S}^1, *)$ -constructible cosheaf, we have one isomorphism class of  $\mathbb{C}$ -vector spaces over any type I open set and another isomorphism class of  $\mathbb{C}$ -vector spaces over any type II open set. The maps  $a$  and  $b$  are therefore given (up to isomorphism) by the extension maps from two type I open sets  $U, W$ , one on either side of the basepoint, to the type II open set  $V$ , where  $U, W \subseteq V$ , as in Figure 3.2.  $\square$

### 3.3 Bisheaves around $(\mathbb{S}^1, *)$

**Definition 3.3.1.** A *bisheaf* is a triple  $(\overline{F}, \underline{F}, F)$  where  $\overline{F}$  is a sheaf over  $\mathbb{X}$ ,  $\underline{F}$  is a cosheaf under  $\mathbb{X}$ , and  $F$  is a collection of maps  $F(U) : \overline{F}(U) \rightarrow \underline{F}(U)$  such that for all  $V \subseteq U$  pairs of path connected open subsets of  $\mathbb{X}$ , the diagram in Figure 3.4 commutes.

$$\begin{array}{ccc} \overline{F}(U) & \xrightarrow{\overline{F}(V \subseteq U)} & \overline{F}(V) \\ F(U) \downarrow & & \downarrow F(V) \\ \underline{F}(U) & \xleftarrow{\underline{F}(V \subseteq U)} & \underline{F}(V) \end{array}$$

**Figure 3.4:** Commutative diagram for defining a bisheaf

**Definition 3.3.2.** A *bisheaf map*  $\overline{\alpha} : \overline{F} \rightarrow \overline{G}$  is a pair of maps  $(\overline{\alpha}, \underline{\alpha})$  where  $\overline{\alpha} : \overline{F} \rightarrow \overline{G}$  is a sheaf map and  $\underline{\alpha} : \underline{G} \rightarrow \underline{F}$  such that for all path connected open sets  $U \in \mathcal{B}$ , the diagram in Figure 3.5 commutes.

$$\begin{array}{ccc} \overline{F}(U) & \xrightarrow{\overline{\alpha}} & \overline{G}(U) \\ F(U) \downarrow & & \downarrow G(U) \\ \underline{F}(U) & \xrightarrow{\underline{\alpha}} & \underline{G}(U) \end{array}$$

**Figure 3.5:** Commutative diagram for defining a map of bisheaves

**Definition 3.3.3.** A bisheaf  $(\overline{F}, \underline{F}, F)$  is  $(\mathbb{S}^1, *)$ -constructible (or just constructible) if  $\overline{F}$  and  $\underline{F}$  are both  $(\mathbb{S}^1, *)$ -constructible. Let  $\text{Bish}(\mathbb{S}^1)$  be the category of  $(\mathbb{S}^1, *)$ -constructible bisheaves together with bisheaf maps between them.

**Theorem 3.3.4.** A  $(\mathbb{S}^1, *)$ -constructible bisheaf  $(\overline{F}, \underline{F}, F)$  around  $\mathbb{S}^1$  is equivalent to a collection of  $\mathbb{C}$ -vector spaces  $A, B, C, D$  and linear maps  $a, b, c, d, e, f$  in the shape of Figure 3.6.

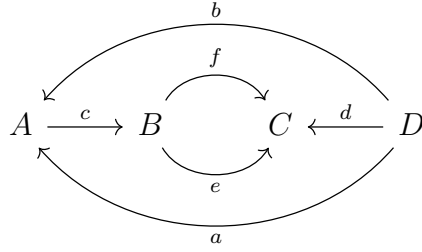

**Figure 3.6:** Diagram of vector spaces and linear maps equivalent to a  $(\mathbb{S}^1, *)$ -constructible bisheaf

*Proof.* This follows by combining Theorem 3.1.5 with Theorem 3.2.5 together with the fact that a bisheaf comes with the data of how to map from the sheaf to the cosheaf,  $F$ . The vector spaces  $A, D$  and the linear maps  $a$  and  $b$  come from the sheaf  $\overline{F}$ , while the vector spaces  $B, C$  and the linear maps  $e$  and  $f$  come from the cosheaf  $\underline{F}$ . The linear map  $c$  is given (up to isomorphism) by  $F(U) : \overline{F}(U) \rightarrow \underline{F}(U)$  for some type I open  $U \in \mathcal{B}$  and the linear map  $d$  is given (up to isomorphism) by  $F(V) : \overline{F}(V) \rightarrow \underline{F}(V)$  for some type II open  $V \in \mathcal{B}$ .  $\square$

**Definition 3.3.5.** An *isobisheaf* around  $\mathbb{X}$  is a bisheaf  $(\overline{I}, \underline{I}, I)$  where  $\overline{I}$  is an episheaf and  $\underline{I}$  is a monocosheaf. For a  $(\mathbb{S}^1, *)$ -constructible bisheaf  $\overline{F}$ , define the *isofication* to be the isobisheaf  $\text{Iso}(\overline{F}) := (\text{Epi}(\overline{F}), \text{Mon}(\underline{F}), \underline{\eta} \circ F \circ \overline{\eta})$  where  $\overline{\eta} : \text{Epi}(\overline{F}) \hookrightarrow \overline{F}$  is the inclusion of sheaves and  $\underline{\eta} : \text{Mon}(\underline{F}) \twoheadrightarrow \underline{F}$  is the projection of cosheaves.

**Theorem 3.3.6.** Let  $(\overline{I}, \underline{I}, I)$  be an isobisheaf around  $\mathbb{S}^1$ . Then the image  $\text{im}I$  is a colocal system and the coimage of  $\text{coim}I$  is a local system. Furthermore, the colocal and local systems are equivalent.

A proof is given in Proposition 5.6 of [11].

**Definition 3.3.7.** Define the assignment  $\text{Ploc} : \text{Bish}(\mathbb{S}^1) \rightarrow \text{Loc}(\mathbb{S}^1)$  which sends the bisheaf  $\overline{F}$  to the image of  $\eta \circ F \circ \overline{\eta}$  in the isofication  $\text{Iso}(\overline{F})$ . Further, by the universal property of images, for a bisheaf map  $\overline{\alpha} : \overline{F} \rightarrow \overline{G}$ , there is an induced natural transformation  $\text{Ploc}\overline{\alpha} : \text{Ploc}\overline{F} \rightarrow \text{Ploc}\overline{G}$ . This natural transformation is given by the universal maps between the episheaves and between the monocosheaves as in Figure 3.7.

$$\begin{array}{ccc}
 \overline{E}_F & \overset{u_E}{\dashrightarrow} & \overline{E}_G \\
 \downarrow & & \downarrow \\
 \overline{F} & \xrightarrow{\overline{\alpha}} & \overline{G} \\
 F \downarrow & & \downarrow G \\
 \underline{F} & \xrightarrow{\underline{\alpha}} & \underline{G} \\
 \downarrow & & \downarrow \\
 \underline{M}_F & \overset{u_M}{\dashrightarrow} & \underline{M}_G
 \end{array}$$

**Figure 3.7:** Diagram showing the universal arrows  $u_E$  and  $u_M$  induced by bisheaf map  $\overline{\alpha}$  together with the universality of episheaves and monocosheaves

By Theorem 3.3.6, each image  $\text{Ploc}(\overline{F})$  is a local system, and as mentioned above, a bisheaf map  $\overline{\alpha} : \overline{F} \rightarrow \overline{G}$  induces a natural transformation between the local systems  $\text{Ploc}(\overline{F})$  and  $\text{Ploc}(\overline{G})$ , so  $\text{Ploc}$  is functorial.

**Theorem 3.3.8.** There is an equivalence of categories between  $\text{Loc}(\mathbb{S}^1)$  and  $\text{Coloc}(\mathbb{S}^1)$ .

*Proof.* Since the restriction maps of a local system are all isomorphisms and the extension maps of a colocal system are also all isomorphisms, these maps are invertible. Define  $J : \text{Loc} \rightarrow \text{Coloc}$  to be the functor sending the local system  $\overline{L}$  to the colocal system  $\underline{L}$  where

$$\underline{L}(V \subseteq U) = (\overline{L}(V \subseteq U))^{-1}.$$

Define  $I : \text{Coloc} \rightarrow \text{Loc}$  to be the functor sending the colocal system  $\underline{L}$  to the local system  $\overline{L}$  where

$$\overline{L}(V \subseteq U) = (\underline{L}(V \subseteq U))^{-1}.$$

Then because  $(A^{-1})^{-1} = A$ ,  $I \circ J = \text{Id}_{\text{Loc}}$  and  $J \circ I = \text{Id}_{\text{Coloc}}$  on the nose. □

Based on the above we do not distinguish between ‘local system’ and ‘colocal system’ since we are now justified in calling either a ‘local system’, regardless if it is a contravariant functor or a covariant functor.

### 3.4 The Persistent Local System Over $\mathbb{S}^1$ in Degree $d$

**Definition 3.4.1.** Let  $f : \mathbb{X} \rightarrow \mathbb{S}^1$  be a constructible map. Define the sheaf of relative singular homology groups  $\overline{F}_*$  as

$$\overline{F}_*(U) := H_*(\mathbb{X}, \mathbb{X} - f^{-1}(U); \mathbb{C})$$

where the restriction maps  $\overline{F}_*(V \subseteq U) : \overline{F}_*(U) \rightarrow \overline{F}_*(V)$  are given by the induced map  $\iota_* : H_*(Y, Y - f^{-1}(U)) \rightarrow H_*(Y, Y - f^{-1}(V))$  for the inclusion  $\iota : V \subseteq U$  between path connected open subsets of  $\mathbb{S}^1$ .

**Definition 3.4.2.** Let  $f : \mathbb{X} \rightarrow \mathbb{S}^1$  be a constructible map. Define the cosheaf of singular homology groups  $\underline{F}_*$  as

$$\underline{F}_*(U) := H_*(f^{-1}(U); \mathbb{C})$$

where the extension maps are  $\underline{F}_*(V \subseteq U) : \underline{F}_*(V) \rightarrow \underline{F}_*(U)$  are given by the induced map  $\iota_* : H_*(f^{-1}(V)) \rightarrow H_*(f^{-1}(U))$  for the inclusion  $\iota : V \subseteq U$  between path connected open subsets of  $\mathbb{S}^1$ .

Note that it is sufficient to define a (co)sheaf at the level of connected open sets as we do here, because we can extend our definition to an actual (co)sheaf by taking a (co)limit over all connected open subsets of a given general open subset, as in the appendix of [11]. Further, the sheaf defined in 3.4.1 and the cosheaf defined in 3.4.2 are both  $(\mathbb{S}^1, *)$ -constructible by Definition 2.3.3.

Since  $\mathbb{S}^1$  is a orientable manifold, we may fix a generator  $\omega \in H^1(\mathbb{S}^1, \mathbb{C}) \cong \mathbb{C}$  corresponding to a choice of orientation of  $\mathbb{S}^1$ . For  $U \subseteq \mathbb{S}^1$  a path connected open subset, let  $\mu : H^1(\mathbb{S}^1, \mathbb{S}^1 - U) \rightarrow H^1(\mathbb{S}^1)$  be an isomorphism (note  $\mu$  depends on the open set  $U$ ). Fix a constructible map  $f : \mathbb{X} \rightarrow \mathbb{S}^1$ . Then  $f$  induces a homomorphism  $f^* : H^1(\mathbb{S}^1, \mathbb{S}^1 - U) \rightarrow H^1(\mathbb{X}, \mathbb{X} - f^{-1}(U))$ . Hence  $(f^* \circ \mu^{-1})(\omega) |_U$  is a generator of  $H^1(\mathbb{X}, \mathbb{X} - f^{-1}(U))$ . Therefore the cap product  $\frown (f^* \circ \mu^{-1})(\omega) |_U : H_{d+1}(\mathbb{X}, \mathbb{X} - f^{-1}(U)) \rightarrow H_d(f^{-1}(U))$  is a well-defined map from the sheaf  $\overline{F_{d+1}}(U)$  to the cosheaf  $\underline{F}_d(U)$ .

$$\begin{array}{ccc}
H_{d+1}(\mathbb{X}, \mathbb{X} - f^{-1}(U)) & \xrightarrow{\overline{F}(V \subseteq U)} & H_{d+1}(\mathbb{X}, \mathbb{X} - f^{-1}(V)) \\
\downarrow \frown (f^* \circ \mu^{-1})(\omega) |_U & & \downarrow \frown (f^* \circ \mu^{-1})(\omega) |_V \\
H_d(f^{-1}(U)) & \xleftarrow{\underline{F}(V \subseteq U)} & H_d(f^{-1}(V))
\end{array}$$

**Figure 3.8:** Commutative diagram showing that  $\frown (f^* \circ \mu^{-1})(\omega)$  together with  $\overline{F_{d+1}}$  and  $\underline{F}_d$  defines a bisheaf

**Definition 3.4.3.** Fix a degree  $d$ . Consider the assignment  $\text{Bish}_d : \text{Con}(\mathbb{S}^1, *) \rightarrow \text{Bish}(\mathbb{S}^1)$  which sends the constructible map  $f$  to the bisheaf  $(\overline{F_{d+1}}, \underline{F}_d, F)$  where  $\overline{F_{d+1}}$  is the sheaf of relative singular homology groups in degree  $d + 1$  as in definition 3.4.1,  $\underline{F}_d$  is the cosheaf of singular homology groups in degree  $d$  as in definition 3.4.2, and  $F$  is defined for connected open set  $U$  as  $F(U) = \frown (f^* \circ \mu^{-1})(\omega) |_U$ . The fact that  $(\overline{F_{d+1}}, \underline{F}_d, F)$  is a bisheaf follows from the naturality of the cap product, see Figure 3.8. Let  $c : f \rightarrow g$  be a morphism in  $\text{Con}(\mathbb{S}^1, *)$  where  $f : \mathbb{X} \rightarrow \mathbb{S}^1$  and  $g : \mathbb{Y} \rightarrow \mathbb{S}^1$ . Then  $c$  is a continuous map  $c : \mathbb{X} \rightarrow \mathbb{Y}$  and restricting to  $\mathbb{X} - f^{-1}(U)$  yields  $c |_{\mathbb{X} - f^{-1}(U)} : \mathbb{X} - f^{-1}(U) \rightarrow \mathbb{Y} - g^{-1}(U)$ . Therefore we have the horizontal maps induced by  $c$ ,  $\overline{c}_*$  and  $\underline{c}_*$ , which are shown in Figure 3.9. Note this diagram commutes for any path connected open subset  $U$  also follows by the naturality of the cap product.

**Definition 3.4.4.** Define the *persistent local system in degree  $d$* ,  $\text{Ploc}_d : \text{Con}(\mathbb{S}^1, *) \rightarrow \text{Loc}(\mathbb{S}^1)$ , to be the composition of functors  $\text{Ploc}_d = \text{Ploc} \circ \text{Bish}_d$ .

$$\begin{array}{ccc}
H_{d+1}(\mathbb{X}, \mathbb{X} - f^{-1}(U)) & \xrightarrow{\bar{c}_*} & H_{d+1}(\mathbb{Y}, \mathbb{Y} - g^{-1}(U)) \\
\downarrow \smile_{(f^* \circ \mu^{-1})(\omega)|_U} & & \downarrow \smile_{(g^* \circ \mu^{-1})(\omega)|_U} \\
H_d(f^{-1}(U)) & \xrightarrow{c_*} & H_d(g^{-1}(U))
\end{array}$$

**Figure 3.9:** Commutative diagram showing the functoriality of  $\text{Bish}_d$

# Chapter 4

## The Grothendieck Group of $\text{Loc}(\mathbb{S}^1, \text{Vec})$

In this section, we characterize the Grothendieck group (Definition 4.0.3) of the abelian category  $\text{Loc}(\mathbb{S}^1)$ . Our method for accomplishing this will be to compute the Grothendieck group of a simpler category  $\text{Vec}^{\mathbb{Z}}$  for which the indecomposables are readily computable. Further, there is an equivalence of categories between  $\text{Vec}^{\mathbb{Z}}$  and  $\text{Loc}(\mathbb{S}^1)$ , which yields an isomorphism of Grothendieck groups.

**Definition 4.0.1** (Chapter 7 of [12]). An *abelian category* is a category containing a 0 object, all binary products and coproducts, all kernels and cokernels, such that the following conditions are satisfied:

1. All monomorphisms are kernels
2. All epimorphisms are cokernels
3. Every  $\text{Hom}(A, B)$  is an abelian group such that composition is bilinear.

Note that  $\text{Vec}$  and  $\text{Loc}(\mathbb{S}^1, \text{Vec})$  are both abelian categories.

**Definition 4.0.2.** In an abelian category, a sequence  $f : A \rightarrow B$  and  $g : B \rightarrow C$  is called *exact* at  $B$  if there is an isomorphism  $\ker g \cong \text{Im} f$  causing the diagram in Figure 4.1 to commute.

Moreover, a sequence  $0 \rightarrow A \rightarrow B \rightarrow C \rightarrow 0$  is a *short exact sequence* if it is exact at  $A$ ,  $B$ , and  $C$ .

$$\begin{array}{ccccc} \ker(g) & \xrightarrow{\cong} & \text{im}(f) & & \\ & \searrow & \swarrow & & \\ A & \xrightarrow{f} & B & \xrightarrow{g} & C \end{array}$$

**Figure 4.1:** Definition of exactness at  $B$

**Definition 4.0.3.** [12] For  $\mathcal{C}$  a skeletally small abelian category, the *Grothendieck group*  $K_0(\mathcal{C})$  is the abelian group with one generator for each isomorphism class of objects  $[A]$  and one relation  $[B] = [A] + [C]$  for each short exact sequence  $0 \rightarrow A \rightarrow B \rightarrow C \rightarrow 0$  in  $\mathcal{C}$ .

**Proposition 4.0.4.** If  $A$  and  $B$  are abelian and equivalent as categories, then  $K_0(A)$  and  $K_0(B)$  are isomorphic.

*Proof.* By [13] Proposition 4.4.5, any equivalence  $F : A \rightarrow B$  can be upgraded to an adjoint equivalence. Further, since right adjoints preserve limits (RAPL) and left adjoints preserve colimits (LAPC), the equivalence will preserve initial objects (colimit over empty diagram) and terminal objects (limit over empty diagram). Further, kernels (pullbacks, hence limits) and cokernels (pushouts, hence colimits) are also preserved by the equivalence. Therefore the equivalence is an exact functor in both directions, so a sequence is short exact in  $A$  if and only if the corresponding sequence in  $B$  is also short exact. Thus the Grothendieck groups are isomorphic since they will have equivalent presentations.  $\square$

**Definition 4.0.5.** Let the *category of  $\mathbb{Z}$  representations*  $\text{Vec}^{\mathbb{Z}}$  be the category where the objects are group homomorphisms  $\varphi : \mathbb{Z} \rightarrow \text{GL}(\mathbb{C}^n)$ ,  $n$  not fixed, and the morphisms  $A : \varphi \rightarrow \psi$  are linear maps  $A : \mathbb{C}^m \rightarrow \mathbb{C}^n$  such that the diagram in Figure 4.2 commutes.

$$\begin{array}{ccc} \mathbb{C}^m & \xrightarrow{A} & \mathbb{C}^n \\ \varphi(1) \downarrow & & \downarrow \psi(1) \\ \mathbb{C}^m & \xrightarrow{A} & \mathbb{C}^n \end{array}$$

**Figure 4.2:** A morphism in the category  $\text{Vec}^{\mathbb{Z}}$

**Proposition 4.0.6.** There is an equivalence of categories between the category of local systems over the circle  $\text{Loc}(\mathbb{S}^1)$  and the category of  $\mathbb{Z}$  representations  $\text{Vec}^{\mathbb{Z}}$ .

*Proof.* Let  $J : \text{Loc}(\mathbb{S}^1) \rightarrow \text{Vec}^{\mathbb{Z}}$  be the functor sending a local system given by  $\mathbb{C}^n$  and isomorphisms  $A$  and  $B$  to the  $\mathbb{Z}$ -representation  $m \mapsto (AB^{-1})^m$ . Let  $I : \text{Vec}^{\mathbb{Z}} \rightarrow \text{Loc}(\mathbb{S}^1)$  be the functor

sending a  $\mathbb{Z}$ -representation  $m \mapsto A^m$  to the local system given by  $\mathbb{C}^m$  with the identity map  $I$  and  $A$ . The natural isomorphism from  $I \circ J$  to  $\text{Id}_{\text{Loc}(\mathbb{S}^1, \text{Vec})}$  is given by  $A^{-1}$  and  $\text{Id}_{\mathbb{C}^n}$  as in Figure 4.3. Going the other direction, note that  $J \circ I = \text{Id}_{\text{Vec}^{\mathbb{Z}}}$ .  $\square$

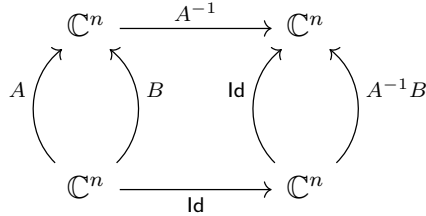

**Figure 4.3:** Natural isomorphism between  $I \circ J$  and  $\text{Id}_{\text{Loc}(\mathbb{S}^1, \text{Vec})}$

**Definition 4.0.7.** An object  $B$  in an abelian category is called *reducible* if there exist nonzero objects  $A$  and  $C$  with morphisms  $f : A \rightarrow B$  and  $g : B \rightarrow C$  such that Figure 4.4 is a short exact sequence.

Objects that are not reducible are called *irreducible*.

$$0 \longrightarrow A \xrightarrow{f} B \xrightarrow{g} C \longrightarrow 0$$

**Figure 4.4:** Short exact sequence for defining decomposable and reducible objects

**Definition 4.0.8.** An object  $B$  is *decomposable* in an abelian category if there exist nonzero objects  $A$  and  $C$  with morphisms  $f : A \rightarrow B$  and  $g : B \rightarrow C$  such that Figure 4.4 is a split exact sequence. Objects that are not decomposable are called *indecomposable*.

**Proposition 4.0.9.**  $K_0(\text{Loc}(\mathbb{S}^1, \text{Vec})) \cong \bigoplus_{\mathbb{C} \setminus \{0\}} \mathbb{Z}$  which is the group of formal integer linear combinations of complex numbers with only finitely many nonzero coefficients.

*Proof.* By Proposition 4.0.6,  $\text{Loc}(\mathbb{S}^1, \mathbb{C})$  and  $\text{Vec}^{\mathbb{Z}}$  are equivalent as categories and both abelian. Hence their Grothendieck groups are isomorphic according to Proposition 4.0.4. Indeed, the indecomposable isomorphism classes in  $\text{Vec}^{\mathbb{Z}}$  are given by Jordan blocks acting on the appropriate

$\mathbb{C}$ -vector space. Moreover, a Jordan block  $J$  cannot be diagonalized further (see [14], Theorem 8.60) so  $[J] \not\cong [A] \oplus [B]$  for two nonzero Jordan blocks  $A$  and  $B$ . Now associate the element  $n\lambda \in \bigoplus_{\mathbb{C} \setminus \{0\}} \mathbb{Z}$  to the  $n$  by  $n$  Jordan block with eigenvalue  $\lambda$ . Note that short exact sequences like that in Figure 4.5 yield the relation  $n\lambda + m\lambda \simeq (n+m)\lambda$  since the Jordan block corresponding to  $(n+m)\lambda$  can be fit into a short exact sequence with Jordan blocks corresponding to  $n\lambda$  and  $m\lambda$ . Moreover, adding arbitrary isomorphism classes of Jordan blocks yields a formal integer linear combination of complex numbers  $\sum_i n_i \lambda_i$ . Therefore  $K_0(\text{Vec}^{\mathbb{Z}}) \cong \bigoplus_{\mathbb{C} \setminus \{0\}} \mathbb{Z}$ .  $\square$

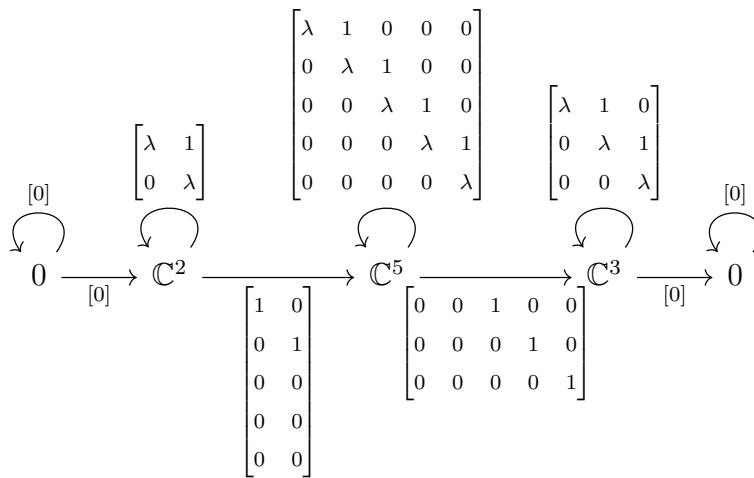

**Figure 4.5:** Example short exact sequence of Jordan blocks which does not split

# Chapter 5

## Generalized Persistence for local systems over the circle.

### 5.1 Constructible Persistence Modules of Persistent Local Systems over $\mathbb{S}^1$

**Definition 5.1.1.** The poset category  $(\mathbb{R}, \leq)$  is a category with real numbers as objects and whose morphisms are arrows  $p \rightarrow q$  whenever  $p \leq q$ .

**Definition 5.1.2.** A *persistence module of local systems* is a functor  $M : (\mathbb{R}, \leq) \rightarrow \text{Loc}(\mathbb{S}^1)$ .

In particular, a persistence module of local systems assigns a local system  $M(p)$  to each real number  $p$  and a morphism of local systems  $M(p \leq q) : M(p) \rightarrow M(q)$  for each  $p \leq q$ .

**Definition 5.1.3.** Let  $S = \{s_1 < s_2 < \dots < s_n\}$  be a finite set of real numbers. An *S-constructible persistence module of local systems* is a persistence module  $M : (\mathbb{R}, \leq) \rightarrow \text{Loc}(\mathbb{S}^1)$  such that

1.  $M(p \leq q) = 0$  for all  $p \leq q < s_1$
2.  $M(p \leq q)$  is an isomorphism for all  $s_i \leq p \leq q < s_{i+1}$  or  $s_n \leq p \leq q$

Persistence modules that are *S-constructible* for some  $S$  are called *constructible*.

For a persistence module of local systems  $M$  to be constructible, there must be a smallest real number  $s_1$  where  $M(s_1) \neq 0$ . Furthermore, the persistence module local systems may only change (up to isomorphism) finitely many times at discretely located real numbers  $s_i$ . An example of a finite (hence constructible) persistence module of  $\mathbb{Z}$ -representations is shown in Figure 5.1, which by the equivalence of categories in Proposition 4.0.6, is equivalent to a finite persistence module of local systems over  $\mathbb{S}^1$ .

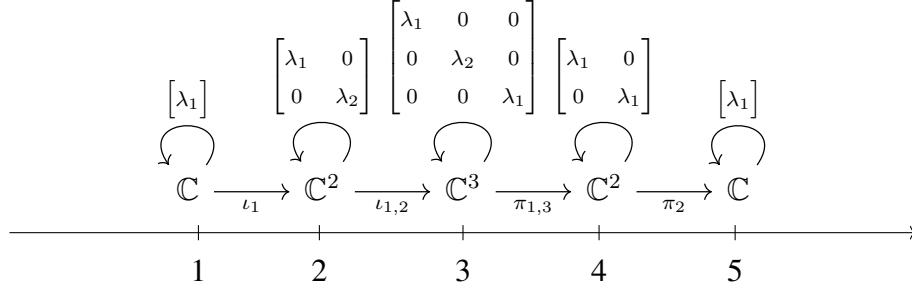

**Figure 5.1:** Example constructible persistence module  $M$  of  $\mathbb{Z}$  representations, where the module is constant for  $p \geq 5$

## 5.2 The Rank Invariant of a Persistence Module of Local Systems

**Definition 5.2.1.** The poset category  $\text{Int}$  is the category where the objects are half open intervals  $[a, b) \subseteq \mathbb{R}$  and the morphisms are set inclusion.

**Definition 5.2.2.** Let  $S = \{s_1 < \dots < s_n\}$  be a finite set of real numbers. A map  $F : \text{Int} \rightarrow K_0(\text{Loc}(\mathbb{S}^1))$  is called  $S$ -constructible if for all  $A, B \in \text{Int}$  where  $A \cap S = B \cap S$ ,  $F(A) = F(B)$ . Maps that are  $S$ -constructible for some  $S$  are called *constructible*.

**Definition 5.2.3.** Let  $M$  be an  $S$ -constructible persistence module of local systems for  $S = \{s_1 < \dots < s_n\}$ . Note that because  $s_i$  are real numbers, there exists  $\delta > 0$  such that  $s_i < s_{i+1} - \delta$  for  $0 \leq i < n$ . Fix  $t > s_n$ . Then the *rank invariant* of  $M$  is the constructible map  $\text{rk}M : \text{Int} \rightarrow K_0(\text{Loc}(\mathbb{S}^1))$  given by

$$\text{rk}M(I) = \begin{cases} [\text{Im}M(p < s_i - \delta)] & \text{for } I = [p, s_i) \\ [\text{Im}M(p < t)] & \text{for } I = [p, \infty) \\ [\text{Im}M(p < q)] & \text{for all other } I = [p, q) \end{cases}$$

The rank invariant of a constructible persistence module of local systems  $\text{rk}M$  takes half open intervals of real numbers  $[p, q)$  to equivalence classes of integer linear combinations of complex numbers  $[\sum_i n_i \lambda_i]$  corresponding to images of the module  $[\text{Im}M(p < q)]$  as in Definition 5.2.3.

Since we are working in the category  $\text{Vec}^{\mathbb{Z}}$ , these images correspond to the image of the linear map  $M(p < q)$ . An example rank invariant is shown in Figure 5.2.

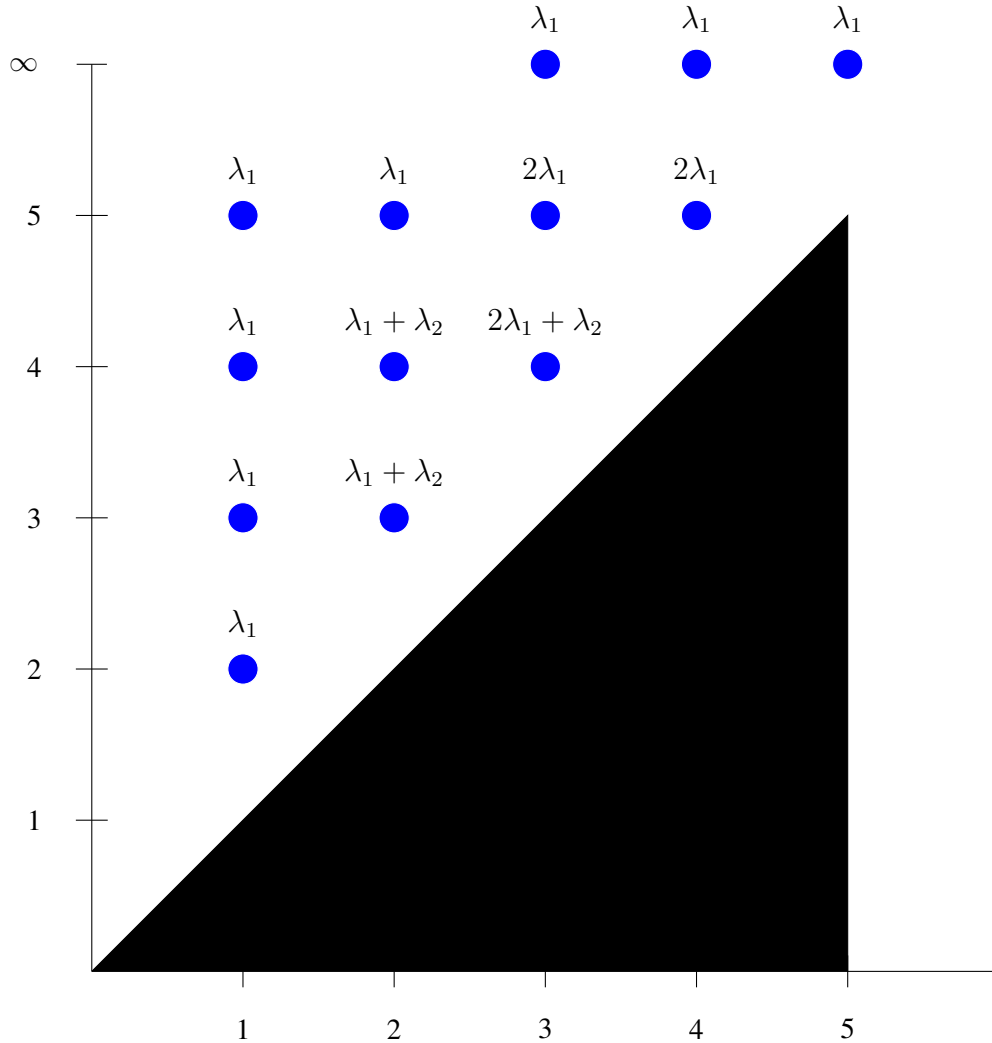

**Figure 5.2:** Example rank invariant  $\text{rk}M$  for the persistence module in Figure 5.1

### 5.3 Generalized Persistence Diagrams

**Definition 5.3.1.** A map  $F : \text{Int} \rightarrow K_0(\text{Loc}(\mathbb{S}^1))$  is called *S-finite* if  $F([a, b]) \neq 0$  implies either  $a \in S$  and  $b \in S$ , or  $b = \infty$ . Maps that are *S-finite* for some  $S$  are called *finite*.

**Theorem 5.3.2.** [15] Fix  $S = \{s_1 < \dots < s_n\}$  and let  $F : \text{Int} \rightarrow K_0(\text{Loc}(\mathbb{S}^1))$  be an  $S$ -constructible map. Then there is an  $S$ -finite map  $G : \text{Int} \rightarrow K_0(\text{Loc}(\mathbb{S}^1))$  such that

$$F(A) = \sum_{A \subseteq B} G(B) \quad (5.1)$$

and  $G$  is called the *Möbius inversion* of  $F$ .

Because Equation 5.1 is a sort of discrete analogue to the fundamental theorem of calculus  $f(x) = \int f'(t)dt$ , we denote the Möbius inversion of an  $S$ -constructible map  $F$  by  $\partial F$ . In fact, some even refer to  $\partial F$  as a ‘combinatorial derivative’.

**Definition 5.3.3.** If a persistence module of local systems  $M$  gives rise to a constructible rank invariant  $\text{rk}M$ , then we denote the Möbius inversion of  $\text{rk}M$  as  $\partial \text{rk}M$ , and we call  $\partial \text{rk}M$  the *generalized persistence diagram* (or just persistence diagram) of  $M$ .

In particular, the persistence diagram  $\partial \text{rk}M$  assigns formal integer linear combinations of complex numbers  $\sum_i n_i \lambda_i$  to half open intervals so that  $\text{rk}M$  and  $\partial \text{rk}M$  satisfy Equation 5.1.

For the next theorem, we define a partial order  $\preceq$  on  $K_0(\text{Loc}(\mathbb{S}^1))$  as  $[a] \preceq [b]$  if and only if  $[b] - [a] = [c]$  for some local system  $c \in \text{Loc}(\mathbb{S}^1)$ . This is equivalent to saying  $[\sum_i n_i \lambda_i] \preceq [\sum_i m_i \gamma_i]$  whenever  $n_i \leq m_i$  for all  $i$ . In other words, we can order local systems (up to isomorphism) by the multiplicities of their associated eigenvalues.

**Theorem 5.3.4.** (Positivity, Proposition 7.1 in [15]) If  $M$  is a constructible persistence module with persistence module  $\partial \text{rk}(M)$ , then for each  $I \in \text{Int}$ ,  $[e] \preceq \partial \text{rk}M(I)$ .

Persistence diagrams of constructible persistence modules of local systems can be visualized as a normal persistence diagram over the wedge but decorated with integer linear combinations of complex numbers  $[\sum_i n_i \lambda_i]$  over each point in the persistence diagram rather than just the rank of a vector space as in Figure 6.9.

Moreover, positivity means that each of these integer linear combinations of complex numbers is equivalent to a formal linear combination of complex numbers with each integer coefficient

being nonnegative, as in the persistence diagram shown in Figure 5.3. For example, it would not be possible to have  $-1(i)$  in a persistence diagram since there is no matrix where the eigenvalue  $i$  has multiplicity  $-1$ . However, it would be possible to have a matrix with eigenvalue  $-i$  which has multiplicity 1.

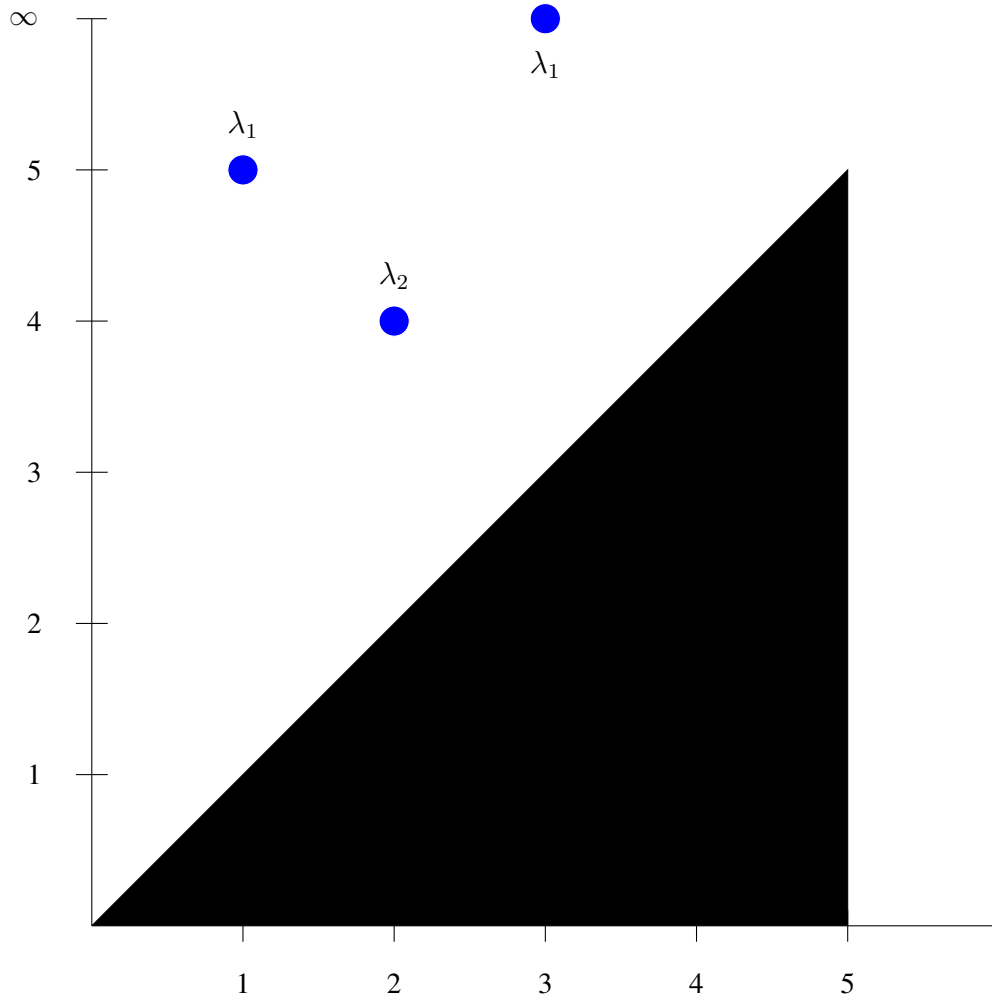

**Figure 5.3:** Example persistence diagram  $\partial \text{rk}M$  obtained by Möbius inverting the rank invariant in Figure 5.2

## 5.4 Stability of Generalized Persistence Diagrams

In this section, we describe a result which justifies the use of generalized persistence diagram with real-world data, which is noisy. This result, known as stability, guarantees that similar samples

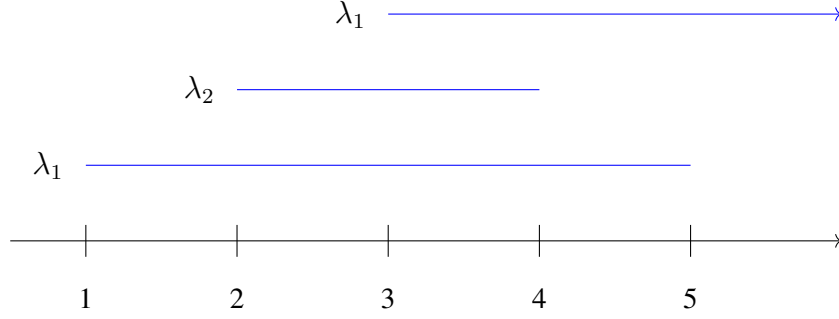

**Figure 5.4:** Equivalent barcode for the persistence diagram in Figure 5.3

will yield similar persistence diagrams. This will be especially important for proving the stability of our pipeline, which we prove in Section 6.

**Definition 5.4.1.** Let  $\mathbb{R} \times_{\varepsilon} \{0, 1\}$  be the poset category  $(\mathbb{R} \times \{0\}) \cup (\mathbb{R} \times \{1\})$  with objects  $(p, s)$  and morphisms  $(p, s) \leq (q, t)$  whenever

- $t = s$  and  $p \leq q$ , or
- $t \neq s$  and  $p + \varepsilon \leq q$ .

Further, let  $\iota_0$  and  $\iota_1$  be the inclusions of the poset category  $(\mathbb{R}, \leq)$  into  $\mathbb{R} \times \{0\}$  and  $\mathbb{R} \times \{1\}$  respectively.

**Definition 5.4.2.** An  $\varepsilon$ -interleaving of two constructible persistence modules  $M$  and  $N$  valued in an abelian category  $C$  is a functor  $E : \mathbb{R} \times_{\varepsilon} \{0, 1\} \rightarrow C$  making the following diagram commute up to natural isomorphism:

$$\begin{array}{ccccc}
 (\mathbb{R}, \leq) & \xrightarrow{\iota_0} & \mathbb{R} \times_{\varepsilon} \{0, 1\} & \xleftarrow{\iota_1} & (\mathbb{R}, \leq) \\
 & \searrow M & \downarrow E & \swarrow N & \\
 & & C & & 
 \end{array}$$

**Definition 5.4.3.** The *interleaving distance* of two constructible persistence modules  $M$  and  $N$  is

$$d_I(M, N) = \inf\{\varepsilon \geq 0 \mid M, N \text{ are } \varepsilon\text{-interleaved.}\}$$

If there is no such  $\varepsilon$  where  $M$  and  $N$  are  $\varepsilon$ -interleaved, then  $d_I(M, N) := \infty$ .

**Definition 5.4.4.** A *matching* between persistence diagrams  $\partial \text{rk} M : \text{Int} \rightarrow \mathbb{G}$  and  $\partial \text{rk} N : \text{Int} \rightarrow \mathbb{G}$  is a map  $\varphi : \text{Int} \times \text{Int} \rightarrow \mathbb{G}$  such that

$$\partial \text{rk} M(I) = \sum_{J \in \text{Int}} \varphi(I, J) \text{ for all } I \in \text{Int}$$

$$\partial \text{rk} N(J) = \sum_{I \in \text{Int}} \varphi(I, J) \text{ for all } J \in \text{Int}$$

**Definition 5.4.5.** The *norm* of a matching is

$$\|\varphi\| := \max_{\{I=[a_1, a_2], J=[b_1, b_2] \mid \varphi(I, J) \neq 0\}} (\max\{|b_2 - a_2|, |b_1 - a_1|\})$$

**Definition 5.4.6.** The *Bottleneck distance* between persistence diagrams  $\partial \text{rk} M : \text{Int} \rightarrow \mathbb{G}$  and  $\partial \text{rk} N : \text{Int} \rightarrow \mathbb{G}$  is

$$d_B(\partial \text{rk} M, \partial \text{rk} N) := \inf_{\varphi} \|\varphi\|$$

which is the infimum of the norms of all matchings  $\varphi$  between  $\partial \text{rk} M : \text{Int} \rightarrow \mathbb{G}$  and  $\partial \text{rk} N : \text{Int} \rightarrow \mathbb{G}$ .

**Theorem 5.4.7.** [Bottleneck stability, Theorem 5.6 in [16]] Let  $\mathbb{C}$  be a small abelian category and  $M, N : (\mathbb{R}, \leq) \rightarrow \mathbb{C}$  be two constructible persistence modules. Then  $d_B(\partial \text{rk} M, \partial \text{rk} N) \leq d_I(M, N)$ .

Theorem 5.4.7 implies that any constructible persistence module of  $\mathbb{Z}$ -representations which is 'close enough' to the module shown in Figure 5.1 in the interleaving distance will have a corresponding persistence diagram which is relatively similar to the persistence diagram in Figure 5.3. Similar persistence diagrams of this type will have points with the same eigenvalue close to the points in the original persistence diagram.

# Chapter 6

## The Pipeline

### 6.1 General Description

In our pipeline, we start with a discrete dynamical system  $(M, d, \varphi)$  consisting of a metric space  $(M, d)$  and a continuous map  $\varphi : M \rightarrow M$  for the dynamics.

**Definition 6.1.1.** Let  $X \subseteq M$  be a finite sample of a discrete dynamical system  $(M, d, \varphi)$ . Without loss of generality, the minimum  $\min_{y \in X} d(\varphi(x), y)$  is unique for all  $x \in X$ . Define the map  $\varphi_X : X \rightarrow X$  as follows:

$$\varphi_X(x) = \arg \min_{y \in X} d(\varphi(x), y).$$

Then  $\varphi_X$  sends the point  $x \in M$  to the point in  $X$  which is closest to the point  $\varphi(x)$ .

**Definition 6.1.2.** [17, Page 61] Let  $X \subseteq M$  be a finite sample. Define the *Vietoris-Rips complex* or *VR complex*  $X_r$  at scale parameter  $r > 0$  to be the simplicial complex

$$X_r := \{\sigma \trianglelefteq \Delta(X) \mid \text{diam}(\sigma) \leq 2r\}.$$

We are now ready to describe the steps for constructing the persistence module of persistent local systems from a finite sample of a discrete dynamical system.

1. Use the metric  $d$  restricted to the sample  $X$  to construct a 1-parameter filtration of Vietoris-Rips complexes  $\{X_r\}$  (Definition 6.1.2) where the inclusion maps are  $\iota_{r \leq s} : X_r \rightarrow X_s$ .
2. For each VR complex  $X_r$ , construct the correspondence  $C_{\varphi_X}(X_r)$  using  $\varphi_X$  as in Definition 6.1.1. Applying this construction to the filtration  $\{X_r\}$  yields a filtration of correspondences  $\{C_{\varphi_X}(X_r)\}$  with the induced inclusions  $\bar{\iota}_{r \leq s} : C_{\varphi_X}(X_r) \rightarrow C_{\varphi_X}(X_s)$ ; see Figure 2.1.

3. For each correspondence of VR complexes  $C_{\varphi_X}(X_r)$ , construct the ouroboros space  $\mathcal{O}_{\varphi_X}(X_r)$ . This yields a filtration of ouroboros spaces  $\{\mathcal{O}_{\varphi_X}(X_r)\}$  with induced inclusions  $\bar{\iota}_{r \leq s} : \mathcal{O}_{\varphi_X}(X_r) \rightarrow \mathcal{O}_{\varphi_X}(X_s)$ ; see Figure 2.8.
4. For each ouroboros space  $\mathcal{O}_{\varphi_X}(X_r)$ , construct the constructible map  $\text{adj}_{\varphi_X}(X_r) : \mathcal{O}_{\varphi_X}(X_r) \rightarrow \mathbb{S}^1$ . The induced inclusions on ouroboros spaces  $\bar{\iota}_{r \leq s}$  commute with the constructible maps  $\text{adj}_{\varphi_X}(X_r)$  and  $\text{adj}_{\varphi_X}(X_s)$ ; see Definition 2.3.7. This results in a filtration  $\text{adj}_{\varphi_X}(X_r)$  of constructible maps to the circle.
5. In each degree  $d$ , apply the  $\text{Bish}_d$  functor to the filtration  $\text{adj}_{\varphi_X}(X_r)$  to get a collection of persistence module of bisheaves, one for each degree,  $\overline{F}_d$ , around  $(\mathbb{S}^1, *)$ ; see Definition 3.4.3.
6. Apply the persistent local system functor  $\text{Ploc}$  (Definition 3.3.7) to each degree  $d$  persistence module of bisheaves to get a collection of degree  $d$  persistence modules of persistent local systems.

**Proposition 6.1.3.** If  $X \subseteq M$  is a finite sample, then  $\text{Ploc}_d(\text{adj}_{\varphi}\{X_r\})$  is a constructible persistence module of persistent local systems.

*Proof.* Consider the set of all distances  $S := \{d(p, q) \mid p, q \in X\}$  between points in the sample  $X$ . Then since  $X$  is finite, so is  $S$ , and hence there are only finitely many Vietoris-Rips complexes  $X_r$  in the filtration  $\{X_r\}$ . This gives rise to finitely many constructible maps  $\text{adj}_{\varphi_X} X_r$ . Applying the  $\text{Ploc}_d$  functor (see Definition 3.4.4) yields a persistence module of finitely many distinct persistent local systems  $\text{Ploc}_d(\text{adj}_{\varphi_X} X_r)$ . Hence  $\text{Ploc}_d(\text{adj}_{\varphi_X} X_r)$  is an  $S$ -constructible persistence module of persistent local systems, meaning this persistence module is constructible.  $\square$

**Definition 6.1.4.** Let  $X$  and  $Y$  be finite sets with maps  $\varphi : X \rightarrow X$  and  $\psi : Y \rightarrow Y$  and respective filtrations of VR complexes  $\{X_r\}$  and  $\{Y_r\}$ . Then denote by  $\{C_{\varphi}(X_r)\}$  and  $\{C_{\psi}(Y_r)\}$  the filtrations of the respective correspondences. An  $\varepsilon$ -homotopy-interleaving of  $\{C_{\varphi}(X_r)\}$  and  $\{C_{\psi}(Y_r)\}$  is a collection of maps  $f_r : C_{\varphi}(X_r) \rightarrow C_{\psi}(Y_{r+\varepsilon})$  and  $g_r : C_{\psi}(Y_r) \rightarrow C_{\varphi}(X_{r+\varepsilon})$  such

that  $g_{r+\varepsilon} \circ f_r$  and  $l_{r \leq r+2\varepsilon}$  are homotopic maps, and  $f_{r+\varepsilon} \circ g_r$  and  $l_{r \leq r+2\varepsilon}$  are homotopic maps for all  $r > 0$  (see the triangles in Figure 6.1).

$$\begin{array}{ccccccc}
C_\varphi(X_r) & \xrightarrow{l_{r \leq r+\varepsilon}} & C_\varphi(X_{r+\varepsilon}) & \xrightarrow{l_{r+\varepsilon \leq r+2\varepsilon}} & C_\varphi(X_{r+2\varepsilon}) & \dots & C_\varphi(X_{s+\varepsilon}) \\
& \searrow f_r & & \nearrow g_{r+\varepsilon} & & & \nearrow g_s \\
& & C_\varphi(Y_{r+\varepsilon}) & & \dots & & C_\varphi(Y_{s+\varepsilon}) \\
& & & & & & \searrow f_{s+\varepsilon} \\
& & & & & & C_\varphi(Y_{s+2\varepsilon})
\end{array}$$

**Figure 6.1:** Triangles for defining an  $\varepsilon$ -homotopy-interleaving

Note that the condition that  $\varepsilon$ -homotopy-interleavings must satisfy is strictly weaker than commutativity, which is the condition required for an interleaving. One can think of this weaker version of commutativity as ‘commuting up to homotopy’.

**Proposition 6.1.5.** Suppose  $X, Y \subseteq M$  are both finite samples with Hausdorff distance  $d_H(X, Y) = \varepsilon/2$ . Let  $\varphi_X : X \rightarrow X$  and  $\varphi_Y : Y \rightarrow Y$  be defined respectively from  $\varphi$  as in Definition 6.1.1. Suppose the map  $\psi : X \cup Y \rightarrow X \cup Y$  given by

$$\psi(p) := \begin{cases} \phi_X(p), & p \in X \\ \phi_Y(p), & p \in Y \end{cases}$$

is Lipschitz continuous with constant  $k$  and

$$N := \frac{2}{\varepsilon} \left( \max_{p \in X \cup Y} d(p, \psi(p)) \right). \quad (6.1)$$

Then the filtrations  $\{C_\psi(X_r)\}$  and  $\{C_\psi(Y_r)\}$  are  $(N + k)\varepsilon$ -homotopy-interleaved.

*Proof.* Because  $d_H(X, Y) = \varepsilon/2$ , there exist maps  $f : X \rightarrow Y$  and  $g : Y \rightarrow X$  such that for all  $x \in X$  and  $y \in Y$ ,  $d(x, f(x)) \leq \varepsilon/2$  and  $d(y, g(y)) \leq \varepsilon/2$ . Fix  $r > 0$  and define  $\bar{f} : C_\psi(X_r) \rightarrow Y_{r+(M+k)\varepsilon} \times Y_{r+(M+k)\varepsilon}$  as

$$\bar{f} : [v_1, \dots, v_n] \times [\psi(v_{i_1}), \dots, \psi(v_{i_m})] \mapsto [f(v_1), \dots, f(v_n)] \times [\psi(f(v_{i_1})), \dots, \psi(f(v_{i_m}))].$$

To see that  $\bar{f} : C_\psi(X_r) \rightarrow C_\psi(Y_{r+(M+k)\varepsilon})$  is well-defined, suppose that  $x, x' \in X$  are points such that  $d(x, x') < r$ . Then applying the triangle inequality to the diagram in Figure 6.2, we have that  $d(\psi(f(v_i)), \psi(f(v_j))) < r + (M + k)\varepsilon$ . Hence  $[f(v_1), \dots, f(v_n)] \times [\psi(f(v_{i_1})), \dots, \psi(f(v_{i_m}))]$  is a cell in  $C_\psi(Y_{r+(M+k)\varepsilon})$ , so  $\bar{f}$  is well-defined. Repeating a similar process as above to  $g$  produces a map  $\bar{g} : C_\psi(Y_{r+(M+k)\varepsilon}) \rightarrow C_\psi(X_{r+2(M+k)\varepsilon})$ .

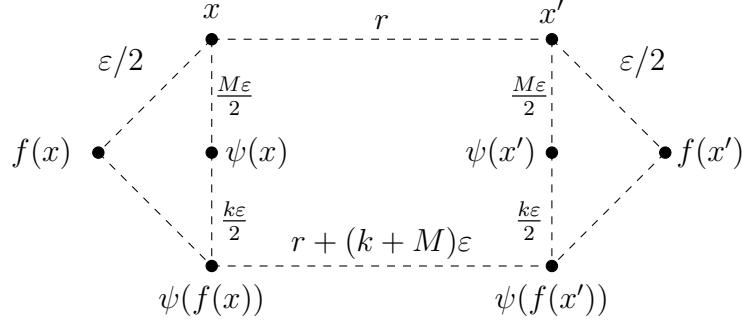

**Figure 6.2:** Upper bounds on the distances between points used in the proof of Proposition 6.1.5

Now, to show that this forms an  $(M + k)\varepsilon$ -homotopy-interleaving, we will show that  $\bar{g} \circ \bar{f}$  is homotopic to  $\iota_{r \leq r+(M+k)\varepsilon}$ , noting that a similar argument works for  $\bar{f} \circ \bar{g}$ . This can be accomplished by showing  $\iota(\sigma \times \tau)$  and  $(\bar{g} \circ \bar{f})(\sigma \times \tau)$  are both faces of some common cell  $\alpha \times \beta$  in  $C_\psi(X_{r+2(M+k)\varepsilon})$ , a concept sometimes referred to as *contiguity*.

Let  $\sigma \times \tau \in C_\psi(X_r)$  be a cell and  $\bar{\pi}_1, \bar{\pi}_2 : C_\psi(X_{r+2(M+k)\varepsilon}) \rightarrow X_{r+2(M+k)\varepsilon}$  be the projections at parameter  $r + 2(M + k)\varepsilon$  onto the first and second component respectively (see Definition 2.1.5).

If we denote by  $\text{vert}(\sigma)$  the set of vertices of simplex  $\sigma$ , then define

$$\alpha := \Delta[\text{vert}(\sigma) \cup \text{vert}(\bar{\pi}_1 \circ g_{r+(M+k)\varepsilon} \circ f_r(\sigma \times \tau))]$$

and

$$\beta := \Delta[\text{vert}(\tau) \cup \text{vert}(\bar{\pi}_2 \circ g_{r+(M+k)\varepsilon} \circ f_r(\sigma \times \tau))]$$

as in Definition 2.1.6. Indeed, if  $u$  and  $v$  are vertices of  $\sigma$ , then  $d(u, v) < r$ , so  $d(v, g(f(u))) < r + 2\varepsilon$  meaning  $\alpha \in X_{r+2\varepsilon}$ . Now if  $u$  and  $v$  are vertices of  $\tau$ , then similarly,  $d(v, g(f(u))) < r + 2(M + k)\varepsilon$ , so  $\beta \in X_{r+2(M+k)\varepsilon}$ .

We have now shown that  $\alpha$  and  $\beta$  are both in  $X_{r+2(M+k)\varepsilon}$ . Further,  $\beta$  is a face of  $\psi(\alpha)$  by construction of  $\bar{f}$  and  $\bar{g}$ . Hence  $\alpha \times \beta \in C_\psi(X_{r+2(M+k)\varepsilon})$ . By definition of  $\alpha$  and  $\beta$ ,  $\alpha \times \beta$  is a cell in  $C_\psi(X_{r+2(M+k)\varepsilon})$  for which  $\sigma \times \tau$  and  $\bar{g} \circ \bar{f}(\sigma \times \tau)$  are both faces (see Figure 6.3), meaning the maps  $\bar{g} \circ \bar{f}$  and  $\iota_{r \leq r+(M+k)\varepsilon}$  are homotopic.  $\square$

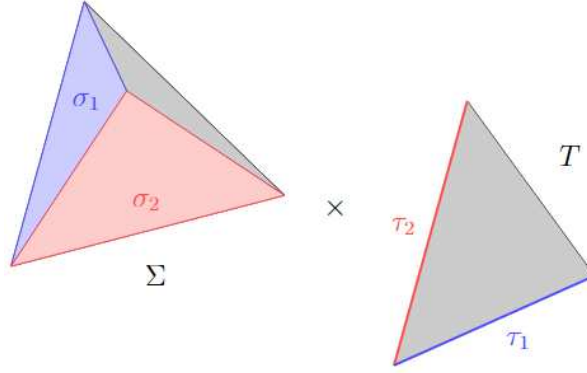

**Figure 6.3:** An example of cells in a correspondence which are faces of a common higher dimensional cell. In this figure,  $\sigma_1 \times \tau_1$  and  $\sigma_2 \times \tau_2$  are both faces of  $\Sigma \times T$ . This means there is a homotopy in this correspondence between a map with image  $\sigma_1 \times \tau_1$  and a map with image  $\sigma_2 \times \tau_2$ .

**Proposition 6.1.6.** If  $X, Y \subseteq M$  are two finite samples of a discrete dynamical system where  $\psi$  is Lipschitz with constant  $k$  and  $M$  as in the statement of Proposition 6.1.5, then for each degree  $d$ ,

$$d_B(\partial \text{rk}(\text{Ploc}_d \circ \text{adj}_\psi(X_r)), \partial \text{rk}(\text{Ploc}_d \circ \text{adj}_\psi(Y_r))) \leq (M + k)d_H(X, Y).$$

*Proof.* Indeed, by 6.1.5, we have (up to some constant) an  $\varepsilon$ -homotopy-interleaving of filtrations of correspondences of VR-complexes of  $X$  and  $Y$ . Further, applying 6.1.3 yields two constructible persistence modules of persistent local systems. Note that the persistent local system is defined using relative and ordinary singular homology, which are homotopy invariant, so for each degree

$d$ , the persistence modules  $\text{Ploc}_d(\{C_\psi(X_r)\})$  and  $\text{Ploc}_d(\{C_\psi(Y_r)\})$  are  $\varepsilon$ -interleaved, since they will now commute up to isomorphism. Lastly, since they are constructible persistence modules, applying Theorem 5.4.7 yields the inequality.  $\square$

## 6.2 A Computational Example

The following example uses the same input as the example in the introduction of [9]. Let  $M$  be the standard unit circle  $\mathbb{S}^1$  embedded in  $\mathbb{C}$  and let  $\varphi : M \rightarrow M$  be given by  $z \mapsto z^2$ , the squaring map. We take the eighth roots of unity (roots of  $f(z) = z^8 - 1$ ) as our sample for this dynamical system, labeled 0 through 7. The resulting filtration of Vietoris-Rips complexes (see Definition 6.1.2) is shown in Figure 6.4.

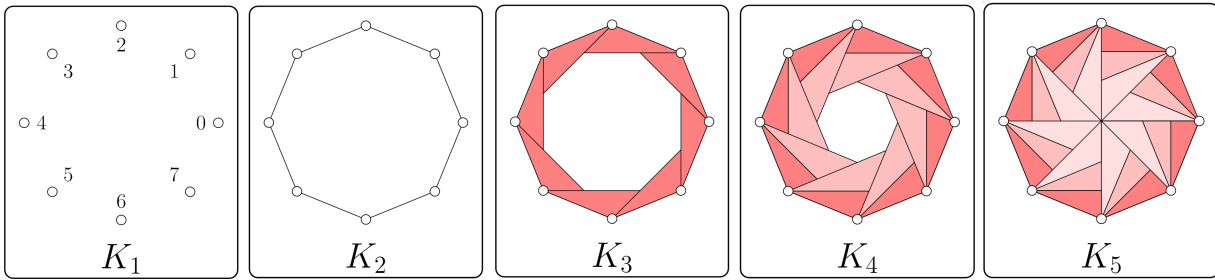

**Figure 6.4:** Filtration of VR complexes for the sampling of the circle

Of particular interest to us is the VR complex shown in  $K_3$ . The correspondence  $C_\varphi(K_3)$  for  $K_3$  is represented in Figure 6.5 both in terms of the products of maximal cells. The way in which these products are glued in the correspondence is indicated by the lines and arrows connecting the entries.

Note that  $K_3$  has  $H_0(K_3; \mathbb{C}) \cong \mathbb{C}$  and  $H_1(K_3; \mathbb{C}) \cong \mathbb{C}$ . Viewing  $C_\varphi(K_3)$  as a space over the circle as in Figure 6.5, one may compute the homology groups of  $C_\varphi(K_3)$  using the 0th and 1st Leray cosheaves of homology with  $\mathbb{C}$  coefficients. This yields  $H_0(C_\varphi(K_3); \mathbb{C}) \cong \mathbb{C}$  and  $H_1(C_\varphi(K_3); \mathbb{C}) \cong \mathbb{C}^9$ . The ouroboros space  $\mathcal{O}_\varphi(K_3)$  (see Definition 2.2.4) has constructible map  $\text{adj}_\varphi(K_3)$  (see Definition 2.3.4).

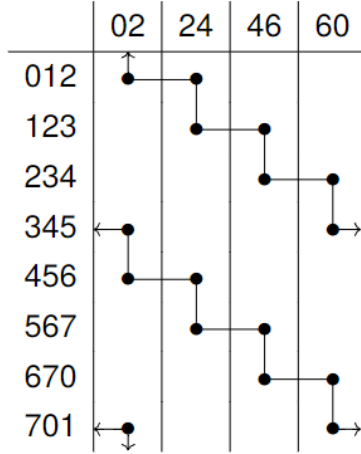

**Figure 6.5:** The cell complex structure for the correspondence. Each dot represents a product of maximal simplices, each line represents a common face along which they are glued, and each arrow indicates that a connection ‘wraps around’ the table.

We now examine the degree 1 bisheaf  $\overline{F}_1$  of  $f$ . Let  $U \in \mathcal{B}$  be a type I open set and  $V \in \mathcal{B}$  be a type II open set (see Definition 2.3.2). Since  $\mathbb{S}^1$  is a 1 dimensional manifold, the degree 1 bisheaf is uniquely determined, up to isomorphism, by the diagram shown in Figure 6.6.

$$\begin{array}{ccccccc}
 \overline{E}(U) \cong \mathbb{C}^9 & \xrightarrow{\text{Id}} & \overline{F}_2(U) \cong \mathbb{C}^9 & \xrightarrow{\text{Id}} & \mathbb{C}^9 \cong \underline{F}_1(U) & \xrightarrow{\pi_9} & \mathbb{C} \cong \underline{M}(U) \\
 \pi_1 \left( \uparrow \right) \pi_2 & & \pi_1 \left( \uparrow \right) \pi_2 & & \pi_1 \left( \downarrow \right) \pi_2 & & \times 1 \left( \downarrow \right) \times 2 \\
 \overline{E}(V) \cong \mathbb{C}^{17} & \xrightarrow{\text{Id}} & \overline{F}_2(V) \cong \mathbb{C}^{17} & \xrightarrow{\sim_{f^1(o_V)}} & \mathbb{C} \cong \underline{F}_1(V) & \xrightarrow{\text{Id}} & \mathbb{C} \cong \underline{M}(V)
 \end{array}$$

**Figure 6.6:** The degree 1 bisheaf  $\overline{F}_1$

Note the sheaf  $\overline{F}_2$  is already an episheaf, so the epification  $\overline{E}$  is  $\overline{F}_2$ . Further note that the monification of  $\underline{F}_1$  denoted  $\underline{M}$  also happens to be the persistent local system for  $\overline{F}_1$  since the image over  $U$  is  $\mathbb{C}$  and the image over  $V$  is also  $\mathbb{C}$ . Further, the degree 1 bisheaves  $\overline{F}_1$  for the VR-complexes  $K_1, K_2, K_4,$  and  $K_5$  each have trivial persistent local system. Therefore the corresponding persistence module of persistent local systems in degree 1 is given by Figure 6.8, and the corresponding persistence diagram is shown in Figure 6.9.

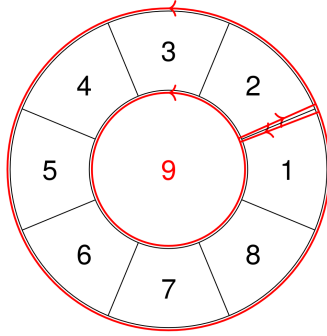

**Figure 6.7:** Generators of  $H_1(C_\varphi) \cong \mathbb{C}^9$  represented (up to homotopy)

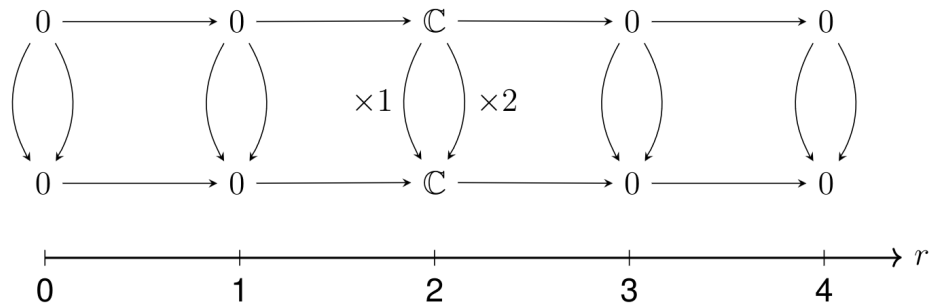

**Figure 6.8:** Constructible persistence module of persistent local systems for the example dynamical system

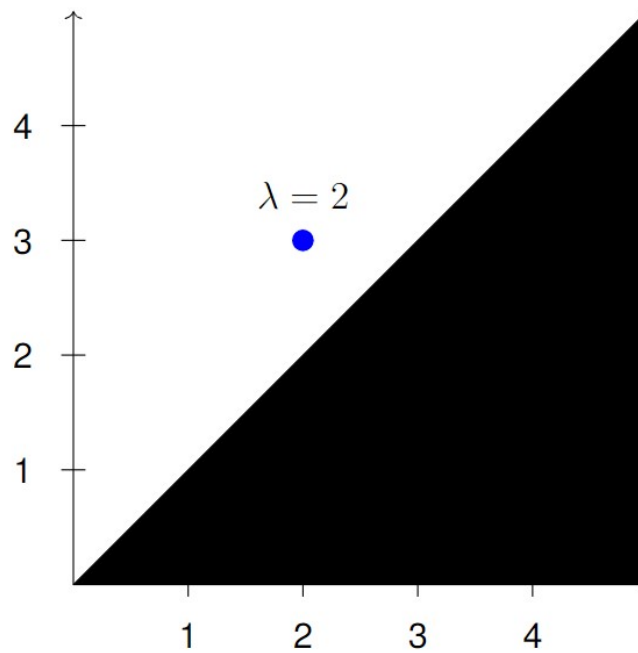

**Figure 6.9:** Persistence diagram of the persistence module in Figure 6.8

# Bibliography

- [1] İsmail Güzel, Elizabeth Munch, and Firas A. Khasawneh. Detecting bifurcations in dynamical systems with crocker plots. *CHAOS*, 32(093111), jun 2022.
- [2] Sunia Tanweer, Firas A. Khasawneh, Elizabeth Munch, and Joshua R. Tempelman. A topological framework for identifying phenomenological bifurcations in stochastic dynamical systems. *Nonlinear Dynamics*, February 2024.
- [3] Sarah Tymochko, Elizabeth Munch, and Firas A. Khasawneh. Using zigzag persistent homology to detect hopf bifurcations in dynamical systems. *Algorithms*, 13(11):278, 2020.
- [4] MR Muldoon, RS MacKay, JP Huke, and DS Broomhead. Topology from time series. *Physica D: Nonlinear Phenomena*, 65(1-2):1–16, 1993.
- [5] Lyle Noakes and Alistair Mees. Dynamical signatures. *Physica D: Nonlinear Phenomena*, 58(1-4):243–250, 1992.
- [6] Jose A Perea and John Harer. Sliding windows and persistence: An application of topological methods to signal analysis. *Foundations of computational mathematics*, 15:799–838, 2015.
- [7] Nicole Sanderson, Elliott Shugerman, Samantha Molnar, James D Meiss, and Elizabeth Bradley. Computational topology techniques for characterizing time-series data. In *Advances in Intelligent Data Analysis XVI: 16th International Symposium, IDA 2017, London, UK, October 26–28, 2017, Proceedings 16*, pages 284–296. Springer, 2017.
- [8] Jose A Perea, Anastasia Deckard, Steve B Haase, and John Harer. Sw1pers: Sliding windows and 1-persistence scoring; discovering periodicity in gene expression time series data. *BMC bioinformatics*, 16:1–12, 2015.
- [9] Herbert Edelsbrunner, Grzegorz Jabłoński, and Marian Mrozek. The Persistent Homology of a Self-Map. *Foundations of Computational Mathematics*, 15:1213–1244, 2015.

- [10] Anders Björner. Posets, Regular CW Complexes and Bruhat Order. *European Journal of Combinatorics*, 5(1):7–16, 1984.
- [11] Robert MacPherson and Amit Patel. Persistent Local Systems. *Advances in Mathematics*, 386:107795, 2021.
- [12] Charles A Weibel. *The K-book: An Introduction to Algebraic K-theory*, volume 145. American Mathematical Soc., 2013.
- [13] Emily Riehl. *Category Theory in Context*. Courier Dover Publications, 2017.
- [14] Sheldon Axler. *Linear Algebra Done Right*. Springer Nature, 2023.
- [15] Amit Patel. Generalized Persistence Diagrams. *Journal of Applied and Computational Topology*, 1(3-4):397–419, 2018.
- [16] Alex McCleary and Amit Patel. Bottleneck Stability for Generalized Persistence Diagrams. *Proceedings of the American Mathematical Society*, 148(733), 2020.
- [17] Herbert Edelsbrunner and John Harer. *Computational Topology: An Introduction*. American Mathematical Society, 2022.