

THESIS

SOIL WATER PHENOMENA OF A SHORTGRASS PRAIRIE SITE

Submitted by

BRUCE PETER VAN HAVEREN

In partial fulfillment of the requirements

for the Degree of Master of Science

Colorado State University

Fort Collins, Colorado

June, 1974

COLORADO STATE UNIVERSITY

June 1974

WE HEREBY RECOMMEND THAT THE THESIS PREPARED UNDER OUR SUPERVISION
BY BRUCE PETER VAN HAVEREN
ENTITLED SOIL WATER PHENOMENA OF A SHORTGRASS PRAIRIE SITE

BE ACCEPTED AS FULFILLING IN PART REQUIREMENTS FOR THE DEGREE OF
MASTER OF SCIENCE

Committee on Graduate Work

[Redacted]
[Redacted]
[Redacted]
[Redacted]

Adviser

W. E. M... ..
Head of Department

ABSTRACT OF THESIS

SOIL WATER PHENOMENA OF A SHORTGRASS PRAIRIE SITE

This thesis represents an investigation of soil water recharge and depletion phenomena on a shortgrass prairie site in northeastern Colorado. Soil type, grazing intensity, and various topographic variables were all studied to determine their influence on the soil water balance. The soil water balance was subdivided into three periods: recharge due to snowmelt, recharge due to spring rainfall, and growing season depletion. It was estimated that over 60% of the winter precipitation was lost to a combination of evaposublimation and wind transport of snow; it is highly likely that wind-transported snow accounts for over half of this loss. Despite this loss, approximately 48% of the total soil water recharge received between growing seasons 1970 and 1971 was derived from snowmelt. On some optimum sites snowmelt accounted for over 70% of the total recharge. Of the many topographic variables affecting snow retention on the prairie, slope exposure to prevailing winds appears to be the most important, with leeward slopes trapping considerably more snow than windward slopes. In evaluating position-on-slope, it was found that sites which occupy the middle and lower one-third slope positions are optimum sites for snow accumulation. In addition, this study supports the conclusions of earlier workers, who found that snow retention is directly related to vegetation height. Under the precipitation regime of 1971, soil water recharge by rainfall appeared to be independent of the various

soil, grazing, and topographic variables investigated. Thus, it is concluded that the spatial distribution of soil water recharge received between growing seasons on the prairie is largely dependent upon patterns of snow retention and redistribution.

Actual evapotranspiration fell below potential evapotranspiration early in the growing season on all sites. Thus, patterns in soil water recharge had an important influence on spatial distribution of seasonal evapotranspiration. This influence apparently overshadowed soil type and grazing intensity effects on soil water depletion.

Soil water potential data, obtained with thermocouple psychrometers, substantially supported the idea that the soil water regime on the shortgrass prairie is indeed dry. Soil water potentials at depths above 40 cm in most soils reached the -70 bar limit by the end of July, 1971. These results indicate the potential usefulness of thermocouple psychrometers in field studies of soil-water and soil-plant-water relations.

Bruce Peter Van Haveren
Department of Earth Resources
Colorado State University
Fort Collins, Colorado 80521
June, 1974

FOREWARD

*I can foretell the way of celestial bodies,
but can say nothing of the movement of a
small drop of water.*

Galileo Galilei

Galileo's apparent frustration over the behavior of water can be interpreted and accepted as a tremendous challenge to students of hydrology. To me it is a challenge to study and master the whole of the hydrologic cycle from the macrolevel to the microlevel--a difficult but exciting endeavor. Investigation of the hydrologic system should be undertaken on a continuum basis, attacking each segment of the system in its turn. The interdisciplinary nature of hydrology dictates that the hydrologist delve into numerous subdisciplines of the physical, biological, and earth sciences, making the search for knowledge an exceedingly enjoyable one.

The significance of my three years at Colorado State University has quite simply and necessarily been the achievement of an understanding of the basic phenomenological relationships governing the hydrologic cycle, that the flow of water through the hydrologic system obeys certain common natural laws.

Traditionally, the graduate thesis has represented the culmination of a research problem--the collection, analysis, and synthesis of knowledge in a particular subject area. I have attempted instead to make this thesis an extension of and outlet for all the knowledge acquired in countless hours of library study, seminar, informal discussion, and classroom participation, as well as in field and

laboratory research. In this respect, I hope this thesis represents a departure from the traditional approach to a Master of Science thesis, and yet still contributes a small amount to the existing knowledge of the hydrologic system.

As with many graduate programs, mine was not an individual effort by any means. My sincere thanks go to my major professor, Dr. W. D. Striffler, and to the members of my graduate committee, Drs. D. A. Jameson, A. Klute, and J. R. Meiman. I am also indebted to Drs. Alan Galbraith and Freeman Smith, for they, as fellow graduate students earlier in my program, contributed much to my educational experience here. The field work would never have been completed without the occasional helping hands of Ray Souther and Eric Sundberg. David Swift and his staff were always willing to lend assistance in computer programming.

Stepp, a colleague and friend, taught me how to be both patient and diligent.

Dr. George E. Hart and Eugene E. Farmer deserve a large measure of credit for encouraging me to continue my education.

I owe my greatest debt of gratitude to my parents, whose faith in me has been primarily responsible for bringing me this far in my educational career.

Finally, through her love and understanding, Pearl shares equally with me the responsibility for the successful completion of this work.

TABLE OF CONTENTS

	<u>Page</u>
Title Page.	i
Signature Page.	ii
Abstract.	iii
Foreword.	v
Table of Contents	vii
List of Tables.	x
List of Figures	xii
Chapter I. INTRODUCTION.	1
Objectives of the Soil Water Studies	1
The IBP Grasslands Biome Program and Pawnee Intensive Site	2
The Central Basin Hydrologic Studies	2
Chapter II. REVIEW OF PERTINENT LITERATURE	5
Grasslands Hydrology	5
Snow Accumulation and Redistribution on the Prairie.	6
The Soil Water Balance	9
Soil water recharge	10
Soil water depletion.	12
Energy Status of Soil Water.	16
Thermocouple Psychrometry.	20
Chapter III. DESCRIPTION OF STUDY AREA	22
The Pawnee Grasslands.	22
The Lynn Lake Watershed.	23
Climate of the Pawnee Grasslands	26
Historical Geology and Geomorphology	28

TABLE OF CONTENTS (continued)

	<u>Page</u>
Soils of the Lynn Lake Watershed	29
Vegetation of the Pawnee Site.	39
Chapter IV. EXPERIMENTAL DESIGN, METHODS, AND INSTRUMENTATION. .	41
Soil Sampling Methods and Laboratory Analysis Techniques . .	43
Soil Water Content Measurement	43
Soil Water Potential Measurement	51
Psychrometer calibration.	53
Field installation of soil psychrometers.	57
Chapter V. STATISTICAL ANALYSIS OF SOIL WATER RECHARGE AND DEPLETION	60
The Water Balance Equation	61
The winter water balance.	62
The growing season water balance.	71
Results of Multiple-Variable Regression Analyses	80
Chapter VI. SOIL WATER BALANCE OF THE LYNN LAKE WATERSHED. . . .	100
The Winter Hydrologic Regime	100
Effects of topography and vegetation height on snow retention	103
The recharge ratio.	112
Soil Water Recharge by Rainfall.	116
Soil Water Depletion and Evapotranspiration.	118
Chapter VII. RESULTS OF THE SOIL WATER POTENTIAL STUDY	121
Confidence Intervals for Field Soil Water Potentials	121
Soil Water Potentials on the Lynn Lake Watershed	123
Applications of Soil Water Potential Data.	129
Chapter VIII. SUMMARY, RECOMMENDATIONS, AND CONCLUSIONS.	132

TABLE OF CONTENTS (continued)

	<u>Page</u>
Summary of Results	132
Recommendations.	135
Conclusions and Significance of Study.	136
Literature Cited.	137
Appendices.	144
Appendix A. Topographic Profiles of Sampling Transects. . .	144
Appendix B. Summaries of Soil Water Content and Soil Water Potential Data.	148
Appendix C. Summaries of Multiple Regression Analyses . . .	156
Appendix D. CONFIDE: A Fortran IV Computer Program for Confidence Interval Calculation	164

LIST OF TABLES

<u>Table</u>		<u>Page</u>
3.1	Soil type-area relationship for the Lynn Lake watershed	25
3.2	Summary of physical properties of the major soils, Pawnee Intensive Site	31
3.3	Desorption characteristics of the major soils, Pawnee Intensive Site (mean desorption data taken from laboratory analysis as described in Chapter IV)	32
4.1	Characteristics of the sampling points on the soil water transects	44
4.2a-d	Sampling design of the soil water transects	47
4.3	Water potentials (in bars) of different NaCl solutions for different temperature ranges.	55
5.1	AOV table for results of the three-way model, slope position X grazing intensity X exposure. The response variable is $(P + \Delta\theta)$ or $(\Delta S + E)$	68
5.2a-c	AOV tables representing the models, (a) slope position X exposure, (b) exposure X grazing intensity, and (c) slope position X grazing intensity. The response variable is $(P + \Delta\theta)$ or $(\Delta S + E)$	69
5.3a-c	AOV tables representing the models, (a) soil type X grazing intensity, (b) aspect X grazing intensity, and (c) slope position X grazing intensity. The response variable is $(P + \Delta\theta_1)$ or early evapotranspiration	78
5.4	AOV table representing the model, slope position X grazing intensity. The response variable is $(P + \Delta\theta_2)$ or late evapotranspiration.	81
5.5	AOV table representing the model, slope position X grazing intensity. The response variable is $(P + \Delta\theta_T)$ or total evapotranspiration	85
5.6	The variables used in the six regression analyses . . .	88
5.7	Matrix of simple correlation coefficients for all possible combinations of variables.	91
5.8	Regression summary for snowmelt recharge.	96

LIST OF TABLES (continued)

<u>Table</u>	<u>Page</u>
5.9	Regression summary for rainfall recharge. 96
5.10	Regression summary for total recharge 98
5.11	Regression summary for growing season evapotranspiration. 98
5.12	Regression summary for early evapotranspiration 99
5.13	Regression summary for late evapotranspiration. 99
6.1a-b	AOV tables representing the slope position X exposure and slope position X grazing intensity models. The recharge ratio, θ_r , is the response variable. 113
6.2	Regression summary for the analysis of the recharge ratio. The regression AOV, regression coefficients, and standard error of estimate are given in Appendix C. The test was significant at the 0.99 level. 114
7.1	Predicted soil water potentials and associated 95% and 99% confidence intervals for the 20 cm depth in Shingle loam for the 1971 growing season. 122

LIST OF FIGURES

<u>Figure</u>		<u>Page</u>
3.1	Soils map of Lynn Lake watershed.	Back Pocket
3.2	Topographic map of Lynn Lake watershed.	Back Pocket
3.3	Topographic map of Lynn Lake.	24
3.4	Desorption curve for undifferentiated soil.	33
3.5	Desorption curve for Vona sandy loam.	34
3.6	Desorption curve for Ascalon sandy loam	35
3.7	Desorption curve for Renohill sandy loam.	36
3.8	Desorption curve for Shingle loam	37
3.9	Desorption curve for Shingle-Renohill complex	38
3.10	Vegetation map of Lynn Lake watershed	Back Pocket
4.1	Soils map of the intensively-used pastures in the Lynn Lake watershed, showing microwatersheds and sampling transects.	42
4.2	Diagram of thermocouple psychrometer probe used in the study	52
4.3	Design of psychrometer field installation	58
5.1	The growing season trend in soil water storage at depths below 150 cm. Values represent the mean of 5 samples. Tubes sampled include #9 and #13 of Tran- sect No. 1 (heavily grazed); #7 of Transect No. 2 (lightly grazed); and #6 and #16 of Transect No. 3 (moderately grazed)	63
5.2a	Soil water content as a function of both time and depth for the 1970-71 recharge period, averaged over all soil types and grazing treatments	64
5.2b	Soil water content as a function of both time and depth for the 1971 depletion period, averaged over all soil types and grazing treatments	65
5.3	The interactive effects of slope position and grazing intensity on $(P + \Delta\theta)$ or $(\Delta S + E)$	72

LIST OF FIGURES (continued)

<u>Figure</u>		<u>Page</u>
5.4	Seasonal distribution of soil water storage by grazing treatment	74
5.5	Seasonal distribution of soil water storage by grazing treatment	76
5.6	Seasonal distribution of soil water depletion by soil type for the heavily-grazed transect.	82
5.7	Seasonal distribution of soil water depletion by soil type for the moderately-grazed transect	83
5.8	Seasonal distribution of soil water depletion by soil type for the lightly-grazed transect.	84
5.9	The interactive effects of slope position and grazing on $(P + \Delta\theta_T)$ or total evapotranspiration for the growing season.	86
6.1a-b	Photographs showing the effects of exposure and slope position on snow accumulation on the shortgrass prairie	106
6.1c-d	Photographs showing the effects of exposure and slope position on snow accumulation on the shortgrass prairie	107
6.2a-b	Photographs showing the effect of vegetation height on snow accumulation on the shortgrass prairie. . . .	110
6.2c-d	Photographs showing the effect of vegetation height on snow accumulation on the shortgrass prairie. . . .	111
7.1	Soil water potential as a function of both depth and time for the Ascalon sandy loam site, 1971 growing season.	124
7.2	Soil water potential as a function of both depth and time for the undifferentiated bottomland soil site, 1971 growing season	125
7.3	Soil water potential as a function of both depth and time for the Renohill sandy loam site, 1971 growing season.	126
7.4	Soil water potential as a function of both depth and time for the Shingle loam site, 1971 growing season	127

LIST OF FIGURES (continued)

<u>Figure</u>		<u>Page</u>
7.5	Comparison of field vs laboratory soil water desorption curves for the 40 cm depth in Shingle loam soil.	131
A1	Topographic profile of the lightly-grazed transect, showing the 19 sampling points.	145
A2	Topographic profile of the moderately-grazed transect, showing the 18 sampling points.	146
A3	Topographic profile of the heavily-grazed transect, showing the 22 sampling points.	147

CHAPTER I

INTRODUCTION

*In nature there is no effect without cause;
once the cause is understood there is no need
to test it by experience.*

Leonardo da Vinci

Objectives of the Soil Water Studies

This study, initiated in June, 1970, was designed to supplement the original soil water balance investigation reported by Galbraith (1971). Whereas the earlier study was confined to the Ascalon soil series, this study dealt with all the major soil types within the central basin watershed on the Pawnee Intensive Site, northeastern Colorado. Both soil water investigations were part of the Hydrologic Process Studies of the International Biological Program, Grasslands Biome.

The specific objectives of this soil water study are summarized as:

- i. to determine certain physical properties of the major soils found within the central basin on the Pawnee Site,
- ii. to evaluate the water retention characteristics of the major soils,
- iii. to investigate the effects of soil type and certain topographic variables on the soil water balance, and
- iv. to study, on a preliminary basis, the seasonal trends in soil water potential as measured with thermocouple psychrometers.

Two separate yet related minor investigations were carried out concurrently with this study. One of these dealt with a procedure for

calibrating thermocouple psychrometers and is included in Chapter IV. The other investigation, included in Chapter VII, is a comparison of soil water desorption curves developed from laboratory data with curves developed from field data.

The IBP Grasslands Biome Program and Pawnee Intensive Site

The International Biological Program (IBP) is involved in a large-scale study of productivity and human welfare. The United States' effort in the IBP includes the *Analysis of Ecosystems* project, of which the Grassland Biome study is a major part. The Grassland Biome, then, is dedicated to the analysis of the structure and function of grassland ecosystems. One of these ecosystems, the shortgrass prairie, has been subjected to intensive study at the Pawnee Site in northeastern Colorado.

The Pawnee Site study involves a total systems approach to ecosystem research. Several subsystems are recognized and can be classified as either biotic or abiotic in nature. The biotic studies are further subdivided, using the trophic level classification scheme, into the producer, consumer, and decomposer components. The abiotic factors, namely solar radiation, wind, and precipitation, are treated as primary driving variables which regulate the nutrient, heat, and water cycles within the overall system.

The Central Basin Hydrologic Studies

On the semiarid prairie, water has been recognized as a very influential and often critical factor in primary productivity (Tomanek 1959, Dahl 1963, Striffler 1969, Galbraith 1971). Accordingly, the

Hydrologic Process Studies were initiated in 1968 for the purpose of investigating the grassland hydrologic cycle. In two separate reports, Smith and Striffler (1969) and Galbraith (1969) discuss the experimental design of the hydrology study on the Pawnee Intensive Site. A central basin, the Lynn Lake watershed, was chosen for the site of the intensive hydrologic process studies. Eight 0.5 hectare microwatersheds, two replicates each of four grazing treatments, were located within the central basin.

The central basin hydrologic study includes, as one of its primary objectives, the development of a hydrologic simulation model. A hierarchical simulation approach is envisioned (Smith 1971a), where construction of models of individual processes is the first step. The end product will be a spatial, event-oriented model which will be coupled with a plant production model, utilizing the distribution of soil water potential at a given depth for the process-response link. Process-response links with other trophic levels are also planned.

To date, studies on the infiltration characteristics of the principal soils (Smith 1971a, Rauzi and Smith 1973) and the intra-seasonal soil water regime of the microwatersheds (Galbraith 1971) have been completed. Smith (1971b) developed an infiltration model based on data collected within the central basin watershed. In addition, precipitation characteristics (Bertolin and Rasmussen 1969, Smith 1971c) and soil characteristics (Franklin 1969, Van Haveren and Galbraith 1971) were investigated. Striffler (1971, 1972) summarized the hydrologic data collected during the 1970 and 1971 field seasons.

This soil water study was expected to add knowledge to the overall central basin study effort in the following ways:

- i. by determining the importance of topography, soil types, and grazing intensity level on the soil water balance of specific sites;
- ii. by determining the importance of snow redistribution and snowmelt recharge to total soil water recharge and depletion; and
- iii. by developing a reliable field method of measuring soil water potential.

Early in the study it was observed that the hydrologic properties of the principal soils on the Pawnee Site were reasonably similar. Also, it was evident that vegetation composition varied only slightly, largely because of the subdued topography. For these reasons, it was hypothesized that soil water recharge and depletion are highly complex phenomena on the prairie, dependent upon numerous interdependent variables.

During the winter of 1970-71 the writer had many opportunities to visually observe snow accumulation patterns on the study area. It was evident that topography and vegetation were important factors in explaining snow retention characteristics of any given site. It was hypothesized, that, for favorable sites, snowmelt recharge contributes more than rain recharge to the pre-growing season soil water balance.

CHAPTER II

REVIEW OF PERTINENT LITERATURE

Remember when discoursing about water to adduce first experience and then reason.

Leonardo da Vinci

Since this thesis is concerned with a wide spectrum of topics, the literature review is more an extensive than intensive study of pertinent literature. I have attempted to cover in somewhat more detail those topics in grassland hydrology which were given only superficial attention in recent theses and reports associated with the IBP Grasslands Biome hydrology project. These topics include edaphic and topographic influences upon the soil water balance, prairie snow hydrology, and the measurement of soil water potential in field situations.

Grasslands Hydrology

Striffler (1969) and Galbraith (1971) recently reviewed the literature pertaining to prairie hydrology. As Galbraith (1971) points out, one of the most significant characteristics of the grassland hydrologic environment is the extremely high potential evapotranspiration, which, on an annual basis, is two to three times greater than precipitation. This factor results in a soil water regime that provides for relatively large infiltration capacities and infrequent runoff events. The generally dry soil water regime also suggests that subsurface flow of water is at least negligible and probably nonexistent.

As part of his doctoral thesis, Galbraith (1971) discusses three significant findings extracted from the study of the seasonal water balance of the Pawnee Site microwatersheds. The soil water balance at the 150 cm and lower depths was essentially static for the period of study. This finding is supported also later in this thesis. Moreover, runoff was discovered to be a very minor component of the microwatersheds' hydrologic balance. Two hydrologic variables were found to be influenced by the level of grazing intensity. As has been shown either directly or indirectly by many workers (e.g., Sharp et al. 1964), runoff from the microwatersheds increased as grazing intensity increased. Finally, snow accumulation and retention was influenced by vegetation height, or indirectly by grazing intensity. This snow retention effect resulted in an ungrazed watershed receiving 3.0 cm more recharge than a heavily-grazed watershed. This difference in recharge resulted in an equivalent increase in evapotranspiration for the ungrazed watershed.

Snow Accumulation and Redistribution on the Prairie

Although snowfall contributes only 10 to 15% to the annual precipitation on the Pawnee Grasslands, differential snow accumulation caused by vegetative and topographic factors may result in significantly large soil water recharge differences between sites. In fact, on some topographic sites, recharge due to snowmelt may actually exceed the water equivalent of gage catch. Differential retention of snow occurs most dramatically during or after winter snowfalls, when lower temperatures and moderate to high winds prevail and the snow is of low density. Several potential snow storage compartments exist in the prairie environment and may be classified as either topographic or vegetative.

Topographic storage on the prairie occurs in depressions and on lee slopes. In the Northern Desert Shrub region, where relief is somewhat less subdued than on the shortgrass prairie, gullies are effective in trapping large quantities of snow. May et al. (1971) suggest that stands of aspen and serviceberry occur in draws and on lee slopes, where snowdrifts accumulate every winter and significantly improve the water relations of these sites. Even on the shortgrass prairie, the lee sides of taller vegetation also trap snow; the woody species, *Gutierrezia sarothrae* (Pursh) Britt. and Rusby and *Atriplex canaescens* (Pursh) Nutt., are prime examples found on the Pawnee Site. In a study of differential snow accumulation on the Red Desert in Wyoming, Hutchison (1965) concluded that significantly more snow accumulates in sagebrush-covered areas than in grass-covered areas, particularly where topographically-induced accumulation is negligible. An even more important vegetative storage compartment for snow is the subcanopy of a uniform vegetation cover whose canopy top produces an aerodynamically rough surface. The individual volumes of these snow storage compartments vary from storm to storm, depending on wind velocity and direction. Cardinal wind direction is nearly always northwest to north during winter and, consequently, snowdrifts appear in the same locations storm after storm and year after year. The physical process of snow deposition in these storage compartments is initiated by the presence of an unconformity in the ground or vegetation surface. This unconformity sets up turbulent eddies, decreasing the horizontal component of the wind velocity. If the moving air mass is carrying snow particles in suspension, the decreased velocities will result in snow deposition. Snow will continue to deposit until the storage volume is

filled. Snow will tend to accumulate to some height, which usually conforms to the plane of zero wind velocity, or to a plane slightly higher where the surface shear stress is not of sufficient magnitude to further erode the snow.

Many workers have observed differential accumulation and redistribution of snow in prairie and other similar environments. Indeed, the same phenomenon occurs in alpine and subalpine areas (Martinelli 1966). The effect is greatly enhanced for the alpine and subalpine, however, because of greater winter precipitation received by these areas. However, very few quantitative studies have been made on the effects of vegetation and topography on snow accumulation in windy environments. Referring to the Canadian prairie, Gray (1970) says that "local variations in topography and vegetal cover may cause major departures from the average uniform snow depth," with each field having its own peculiar catch and retention characteristics. Furthermore, McKay (1970) concludes that land use practices are important factors in the accumulation process. This represents a significant statement and is supported by the findings of Galbraith (1971), reported earlier. Van Haveren and Galbraith (1971) discussed both the vegetative and topographic effects upon snow retention and redistribution, and presented some preliminary data showing the effects of vegetation height and slope position on snow accumulation on the Pawnee Site. For one particular storm in early January, 1971, snow water equivalents on a lee slope were three times greater than the mean value for the watershed.

The effects of vegetation on snow trapping efficiency have been studied rather thoroughly for agronomic situations in the Great Plains

region. Willis and Haas (1971) and Greb and Black (1971) recently reviewed studies dealing with the effects of tall wheatgrass barriers and stubble height on snow retention. In one study, Smika and Whitfield (1966) found that when wheat stubble was allowed to stand over winter, an average of 99% and a maximum of 140% of snowfall precipitation ended up in soil water storage. In comparing stubble and fallow fields over a 20-year period, Stable et al. (1960) discovered that the mean proportion of snowfall held as soil water was 37% and 9% for stubble and fallow fields, respectively. In a recent and very conclusive study, Willis et al. (1969) investigated the characteristics of snowmelt runoff and soil water recharge with stubble height as an independent variable. Both soil water content and snowmelt runoff were found to increase as stubble height increased. Increasing stubble height also hastened the initiation and increased the average rate of snowmelt runoff for snowpacks up to 12 inches (36.5 cm) mean depth. Quite obviously, then, the height of a vegetation cover has an important effect on the snow trapping ability of a site, and a consequent effect on snow redistribution and soil water recharge.

The Soil Water Balance

Many factors influence the water balance of a natural soil profile. Philip (1964) represents the soil water balance with the following equation:

$$\frac{dW}{dt} = v - q - e - T \quad , \quad [2.1]$$

where $\frac{dW}{dt}$ is the rate of change of total water in the soil profile, v is the infiltration rate, q is the rate of drainage through the lower boundary (or loss to groundwater), e is the evaporation rate, and T is the transpiration rate. Integrating with respect to time and using the notation of this thesis, equation [2.1] reduces to

$$\Delta\theta = I - U - E \quad , \quad [2.2]$$

where E includes both evaporation and transpiration. The units are defined now as centimeters depth of water for purposes of this study. The downward drainage term, U , will be shown later to be negligible for this study; a discussion of infiltration (I) phenomena follows. The term $\Delta\theta$, the change in soil water content, was a variable measured in this study.

Soil water recharge. The amount of water infiltrating a soil surface is dependent upon the magnitude and rate of either rainfall or snowmelt, and also upon certain soil, vegetative, and topographic variables. Theoretically, the infiltration process, as a soil water flow phenomena, is dependent upon the hydraulic conductivity and the gradient of hydraulic head. Both of these properties are in turn dependent upon water content and soil structure and texture. Rauzi and Zingg (1956) found that infiltration rates for rangeland soils decreased as range condition deteriorated and increased as soil texture went from a clay loam to a sand. As a result of further studies, Rauzi et al. (1968) concluded that surface condition (reflecting land use practices) was probably more important than soil texture. Rauzi and Smith (1973), in an infiltration study recently conducted on the Pawnee Intensive

Site, found the effects of three soils, three grazing intensities, and the soil x grazing intensity interaction to be dependent upon the duration of the infiltration run. The soils used were the Ascalon sandy loam, Shingle loam, and Nunn loam (undifferentiated bottomland soil). After 10 minutes of elapsed time from start of run, only the soil type effect was significant; after 20 minutes elapsed time, soil and grazing intensity effects were both highly significant; after 30 minutes, the soil x grazing intensity interaction became significant. The authors suggest the interaction effect is due largely to the behavior of the Shingle loam soil, which showed very little difference in infiltration rate across the three grazing intensities. The Shingle soil occupies the upper slope positions on the Pawnee Site. Since this soil appeared to have the lowest infiltration rate of the three soils studied for the light- and medium-grazed pastures, one might expect a recharge difference due to position-on-slope on these pastures. For the heavily-grazed pasture, the 60-min. infiltration rates were essentially the same for the three soils.

Slope steepness and rill and microdepression patterns will also influence infiltration amounts by controlling the velocity of overland flow and depth of ponded water. Duley and Kelly (1939), working with slopes from 2 to 10%, determined that degree of slope had only a slight effect on infiltration. Wolff (1970), in a review of grassland infiltration literature, concluded that other factors such as cover type, soil type, and seasonal variability generally overshadow slope effects for slopes less than 20%.

Gray et al. (1969) discuss the conditions under which soil freezing will affect infiltration rates. In general, it is recognized that

the infiltration process under frozen soil conditions is highly dependent upon the state and content of soil water and also upon its vertical distribution within the surface profile. Accordingly, the snowmelt runoff characteristics will also depend upon frozen soil conditions. Haupt (1967) did a rather thorough study of infiltration and overland flow characteristics of various ground cover types with and without a snow cover. The transmission characteristics of various types of soil frost were described. Granular- and stalactite-type frosts actually improved infiltration over that of unfrozen soil in some instances. The presence of a concrete-type frost, formed under saturated conditions, reduced infiltration and increased overland flow.

Soil water depletion. Basically, the depletion of soil water as a physical process is dependent upon (1) a source of energy to vaporize water at the leaf and soil surfaces, (2) an adequate supply of water in the soil profile, and (3) the dynamics of the movement of water in the soil-plant-atmosphere system. Movement of water in this system is in turn dependent upon the various conductivities and resistances characteristic of the soil, vegetation, and atmospheric environment within and immediately above the soil and vegetation surfaces. The energy available for evapotranspiration is influenced by various meteorological and topographic factors, namely solar radiation, wind, air temperature, aspect, and slope gradient.

The relation of transpiration to soil evaporation can be expected to vary with site conditions. In arid situations it has been found that transpiration is considerably greater than evaporation from the soil surface, the explanation being that under high evaporative conditions a mulch of dry soil forms at the surface, effectively reducing

the movement of water vapor across the soil-air interface (Wiegand and Taylor 1961).

Hillel (1971) discusses the influence of soil properties on evapotranspiration and lists hydraulic conductivity, diffusivity, and the matric potential-water content relationship as properties having an effect on the uptake of water by vegetation. The same factors influence direct evaporative losses from soils. Alizai and Hulbert (1970), in a laboratory experiment, found that the difference in evaporation rates for three different soils (gravelly sand, loam, and silty loam) was related to the water holding capacities of the three soils. Evaporation amounts were higher for the loam soils than for the gravelly sand.

Plant factors affecting evapotranspiration have been discussed by Gates and Hanks (1967), Slatyer (1967), and Kramer (1969). These factors are usually discussed in terms of the individual plant and in terms of the plant community. Single plant factors most commonly given are root volume and density, resistance of the conducting tissue within the plant, and leaf morphology and arrangement. Thus, evapotranspiration rates vary with plant species and perhaps even with varieties and ecotypes within species. Gates and Hanks (1967), again, discuss in some detail those plant community factors which influence evapotranspiration. Generally speaking, evapotranspiration will again vary with species, particularly where a community is dominated by one species. Species diversity and composition, leaf albedo, stage of growth, rooting depth, plant density and spacing, height, canopy structure, and leaf orientation are characteristics of the plant community which influence

evapotranspiration indirectly by controlling the microclimate within and immediately above the vegetation cover (Gates and Hanks 1967, Horton et al. 1970).

Gardner and Ehlig (1963) studied the influence of soil water, leaf water stress, and plant species on transpiration rates. The transpiration rate was found to be non-linearly dependent upon soil water potential. At any particular soil water potential level, transpiration rates were the highest for the heavier soils. Moreover, transpiration rates were highly dependent upon leaf water potential and varied significantly between species at a given leaf water potential. Even more important was their discovery that the lower limit of water available for transpiration was on the order of -30 to -50 bars leaf water potential. This finding is significant in that agricultural plants (cotton and pepper) were used in the study. This suggests that vegetation native to a very dry site, such as the shortgrass prairie, may be capable of carrying on the transpiration process at extremely low soil water potentials.

In a more recent study conducted in the semidesert grass-shrub type, Cable (1969) concluded that high summer evaporation rates masked most of the differences in soil water depletion between species. However, he did discover a time variation in the amount of soil water depleted by different species, according to peak growth period and phenological characteristics.

Because microclimate influences evapotranspiration, soil freezing, and snow accumulation and melt, microclimate differences within a watershed can be expected to affect the hydrologic behavior of land units within a watershed (Sartz 1972). Topographic variables which may

affect microclimate (and, consequently, hydrologic behavior) are elevation, steepness, aspect, and position on the slope (Sartz 1972). Nash (1963) outlines a general method for evaluating the effect of slope and aspect on soil water relationships. He concludes that the greater soil water stresses experienced over longer time periods (resulting from greater soil water depletion) can be expected to occur on southeast through west aspects, because of greater available solar radiation. However, in analyzing his data on solar radiation received by different aspects and slope gradients (Nash 1963, Figure 3), it is apparent that for slopes less than 10% (i.e. less than 6°), the maximum differences in incoming solar radiation between aspects are on the order of only 30 langley days⁻¹, or less than 5% of the daily incoming solar radiation.

Stoekeler and Curtis (1960) investigated the effects of aspect and position-on-slope on the growing season soil water regime of a site in the Driftless Area, characterized by unglaciated loessal soils and an average annual precipitation of 32 inches (91 cm). Relief was between 300 and 350 feet (93 and 1070 meters), and the vegetation was native hardwoods and pine plantations. Mean slope gradients were 35% and 64% for the north and south aspects, respectively. Although their data are presented in terms of soil water content, one is able to reconstruct their results in terms of recharge and depletion rates. For both north and south aspects, the effect of slope position on recharge was evident. Lower slope positions gained water from upper slope positions by subsurface flow. Except for the lower position on the north aspect, all south slope positions had greater depletion rates

than the north slope positions. However, these differences are probably not statistically significant when aspects within a given slope position are compared.

Citing more recent data also collected from the Driftless Area, Sartz (1972) concludes that soil water withdrawal by similar vegetation on similar soils is not strongly affected by aspect.

Energy Status of Soil Water

Recently, scientists working in the field of soil-plant-water relations have advanced the concept of a "soil-plant-atmosphere continuum (SPAC)," where the "continuum" signifies a pathway for water and energy alike in the dynamic soil-plant-atmosphere system (Slatyer and Denmead 1964; Taylor 1964; Cowan 1965; Philip 1966, 1969). Hillel (1971) mentions that, under the SPAC concept, the concept of water potential is "equally valid and applicable in the soil, plant, and atmosphere alike." The term "water potential" is thought to have been first introduced by R. K. Schofield in 1949 (Owen 1952). The water potential can be defined mathematically as

$$\psi = \frac{\mu_W - \mu_W^0}{V_W^0}, \quad [2.3]$$

where $(\mu_W - \mu_W^0)$ is the difference between the chemical potential of water in the system under study and that of pure free water at the same temperature, T (Slatyer 1967); V_W^0 is the molar volume of pure water at temperature T; ψ here is in units of energy per unit volume (erg cm^{-3}), or can be expressed in the dimensionally equivalent terms of bars, atmospheres, or dyne cm^{-2} . Furthermore,

$$\mu_W - \mu_W^0 = RT \ln e/e_0 \quad , \quad [2.4]$$

where R is the universal gas constant, T the temperature, and e/e_0 the relative vapor pressure. The water potential as defined excludes any effects due to gravitational, centrifugal, or electrical force fields (Hillel 1971, p. 54). A total potential of soil water can be defined as

$$\Psi = \psi + \psi_g + \psi_{EF} \quad , \quad [2.5]$$

or

$$\Psi = \psi_\tau + \psi_\pi + \psi_p + \psi_g + \psi_{EF} \quad , \quad [2.6]$$

where $\psi_\tau, \psi_\pi, \psi_p$, and ψ_g represent the component potentials due to matric and capillary forces, osmotic effects, pressure effects, and gravitational force, respectively. ψ_{EF} is an all-inclusive term made up of other external forces which are theoretically possible. A word of caution must be introduced at this point, since equations [2.5] and [2.6] are not theoretically rigorous; the various components identified may not be mutually independent.

The water potential concept is a particularly useful quantitative concept to the hydrologist, who must view the soil-plant-atmosphere continuum in terms of both its individual components and its dynamic nature from a microhydrologic standpoint (Philip 1969). From a systems ecology standpoint, the energy status of water is a most appropriate expression of the amount of water contained in plants and soils, since,

as Kramer (1969) points out, the water potential "appears to be most closely related to the physiological and biochemical processes which control growth."

In recent laboratory and field studies soil water potential has been used frequently to describe the water status of a soil profile. As early as 1952, seed germination was related to levels of water potential (Owen 1952). More recently, Branson, Miller, and McQueen (1965, 1970) used soil water potential (or "soil moisture stress") to describe the status of soil water in studies of plant community - soil water relationships. Papendick et al. (1971) studied soil water potential profiles under a wheat cover throughout an entire growing season. In an experiment in west-central Colorado, Shown et al. (1972) studied soil water potential profiles under both big sagebrush and beardless bluebunch wheatgrass. The minimum water potential to which big sagebrush could extract water was approximately -45 bars. That for bluebunch wheatgrass was slightly higher--about -25 bars. Since water content data were collected simultaneously with water potential data in this study, the authors were able to compare the relative usefulness of these measures in soil-plant-water relations work. They concluded that (1) since water potential has a large range of values compared to the associated water content, it is a more sensitive measure of soil water status; (2) water potential is not affected by textural changes within and between soil profiles, whereas soil water content is; and (3) the water potential data were not affected by variations in soil sample volume.

Various methods have been employed to measure soil water potential. These methods were the subject of two recent reviews by Taylor

(1965) and Wiebe et al. (1971). Basically, the available methods can be broken down into a few distinct categories: gravimetric, pressure membrane, freezing point, resistance units, tensiometric, and psychrometric methods. A thorough review of all these methods is beyond the scope of this thesis; consequently, only the more popular of the field methods will be reviewed briefly. Colman units and other resistance devices have been used to some success (Galbraith 1971). Their chief disadvantages are that a good soil-instrument contact is necessary for accuracy and the lower limit of use appears to be only about -30 bars. McQueen and Miller (1968) have reported much success with the gravimetric filter paper technique. With this technique, a water characteristic curve is developed for common filter paper, relating water content by weight to water potential with the use of controlled humidity atmospheres. Filter paper discs are then weighed and placed at the specified depth in the soil. After a period of equilibration the discs are removed and reweighed and the water potential determined. The primary disadvantage of this method is that it involves destructive sampling of the soil profile.

Psychrometric methods, involving the use of both thermistors and thermocouples, have enjoyed recent popularity. Several advantages are identified with the use of miniature thermistor or thermocouple psychrometers for measuring soil water potentials. The psychrometer measures the thermodynamic water potential as expressed in equation [2.3]. Most other methods are restricted to measurement of only the matric component. Measurement of the entire soil water potential is important since this is the energy status that the plant "sees". Another advantage is that the psychrometer can tolerate relatively

fast changes in soil water potential, which is of critical importance in studies of diurnal trends of soil water energy status. Moreover, if installed properly, the psychrometer represents a very minor disturbance of the soil in which it is placed. Essentially, the psychrometer measurement is an undisturbed sampling technique. Finally, the technique lends itself well to collection of frequent samples and assemblage of large quantities of data, when interfaced with an electronic data acquisition system.

Thermocouple Psychrometry

An exhaustive review of the literature on this subject would, with some certainty, tax the patience of the writer and unquestionably bore the reader. The review which follows then will concentrate on the historical development of thermoelectric psychrometry. Other aspects of this subject have been covered extensively and in much detail in a symposium proceedings volume entitled, "Psychrometry in Water Relations Research" (Brown and Van Haveren 1972).

Hill (1930) appears to have been the first person to use a thermocouple method for measuring water potentials of biophysical systems. However, Spanner (1951) is often credited with developing the prototype of the modern-day thermocouple psychrometer. Spanner employed the Peltier effect in a method of cooling electronically and remotely the sensing junction of the thermocouple. Under high humidity conditions, condensation will occur at the sensing junction. Spanner calibrated his instrument by exposing it to various combinations of electrolyte concentration and temperature. Some years later Richards and Ogata (1958) developed a thermocouple psychrometer which was

somewhat larger in size than the Spanner instrument, and which required the manual placement of a drop of water on the sensing junction. Disadvantages of this instrument were that it required a very sensitive water bath and consequently was strictly a laboratory instrument. In recent years further developments of the Spanner psychrometer have increased its usefulness and popularity over that of the Richard's psychrometer.

Rawlins (1966) and Peck (1968, 1969) have provided us with very good treatments of the theory underlying the thermocouple psychrometer method of measuring water potentials. Rawlins and Dalton (1967) led the way for successful field use of these instruments by showing how temperature fluctuation effects could be minimized. Brown (1970) developed a psychrometer head assembly enclosed by a fine-mesh wire screen and compared the performance of this design with that of the traditional ceramic-cup head assembly. The wire-screen instrument proved to have quicker response times than the ceramic-cup unit, but was more easily exposed to possible contamination. Other recent developments in psychrometry include a thermopile psychrometer (Dove and Bottoms 1969), a thermally-compensated Peltier psychrometer (Hsieh and Hungate 1970), and a Peltier-cooled dewpoint thermocouple hygrometer (Neumann and Thurtell 1972). The dewpoint instrument appears to be more stable than the wet-bulb psychrometer. Recent trends in this field include such developments as a decrease in the size of the head assembly and the possibility of substituting miniature diodes for the thermocouple as the wet-bulb or dewpoint sensor.

CHAPTER III
DESCRIPTION OF STUDY AREA

*Mountains are made by the currents of rivers.
Mountains are destroyed by rains and rivers.*

Leonardo da Vinci

The soil water study was conducted within Sections 15, 22, and 23 of T10N, R66W, 6th P.M. These three sections form a part of the Pawnee Intensive Site on the Central Plains Experimental Range, administered by the USDA Agricultural Research Service. The CPER is located at the far western end of the Pawnee National Grassland, northeastern Colorado. The area is east of U.S. Highway 85, 25 miles south of Cheyenne, Wyoming, and 35 miles northeast of Fort Collins, Colorado.

The Pawnee Grasslands

The Pawnee Grasslands lie in the landform region known as the Colorado Piedmont. The vegetation type is characteristically native shortgrass prairie, interspersed with occasional cropland. Topography is gently rolling with relief generally less than 100 m. Most of the Pawnee National Grassland lies between 1500 and 1800 m (4900 and 5900 feet) elevation. The physiography, geology, natural history, and anthropology of the Pawnee Grasslands region was recently reviewed by Badaracco (1971).

Inspection of topographic maps of the area reveal drainage patterns with a northwest-southeast orientation. The majority of these drainages are intermittent or ephemeral stream courses, and many end in closed basins.

The Lynn Lake Watershed

Lynn Lake is an ephemeral closed basin draining a large portion of the Pawnee Intensive Site. The entire drainage is shown in Figures 3.1 and 3.2 (back pocket). Figure 3.3 is a topographic map of the lake bottom itself. The watershed is 406 hectares (1003 acres) in area with maximum and minimum elevations of 1694.1 and 1642.3 meters (5554.4 and 5384.5 feet), respectively. A soil type - area relationship was determined for the watershed based on the soils map depicted in Figure 3.1. The results are shown in Table 3.1.

Topography of the watershed is typical of that of the Pawnee Grasslands. Slopes greater than 15% make up less than 5% of the area. Upper position slopes, measured at neutron probe sampling tube locations, average 3.3%, whereas mid- and lower-position slopes average 2.9 and 3.4%, respectively. Thus, slope profiles are characterized by a uniform steepness with a slight concave-upward shape. Slope profiles of leeward slopes are particularly important in grassland hydrology studies, from the standpoint of potential snow retention.

Referring to Figure 3.1, the watershed is located within Sections 9, 10, 14, 15, 16, 22, 23, and 24 of T10N, R66W, 6th P.M. All these sections are in native prairie, with the exception of Section 9, which is presently under agricultural use. Sections 15, 22, and 23 have been the most intensively studied in the Grasslands Biome hydrology project. Pastures 15E, 22E, 23W, and 23E have been under the continuous management of the Agricultural Research Service since 1940, and have been subjected to a more or less constant grazing intensity. Pastures 23E, 23W, and 15E have been designated the heavy, light, and moderate use pastures, respectively. These relative grazing intensities

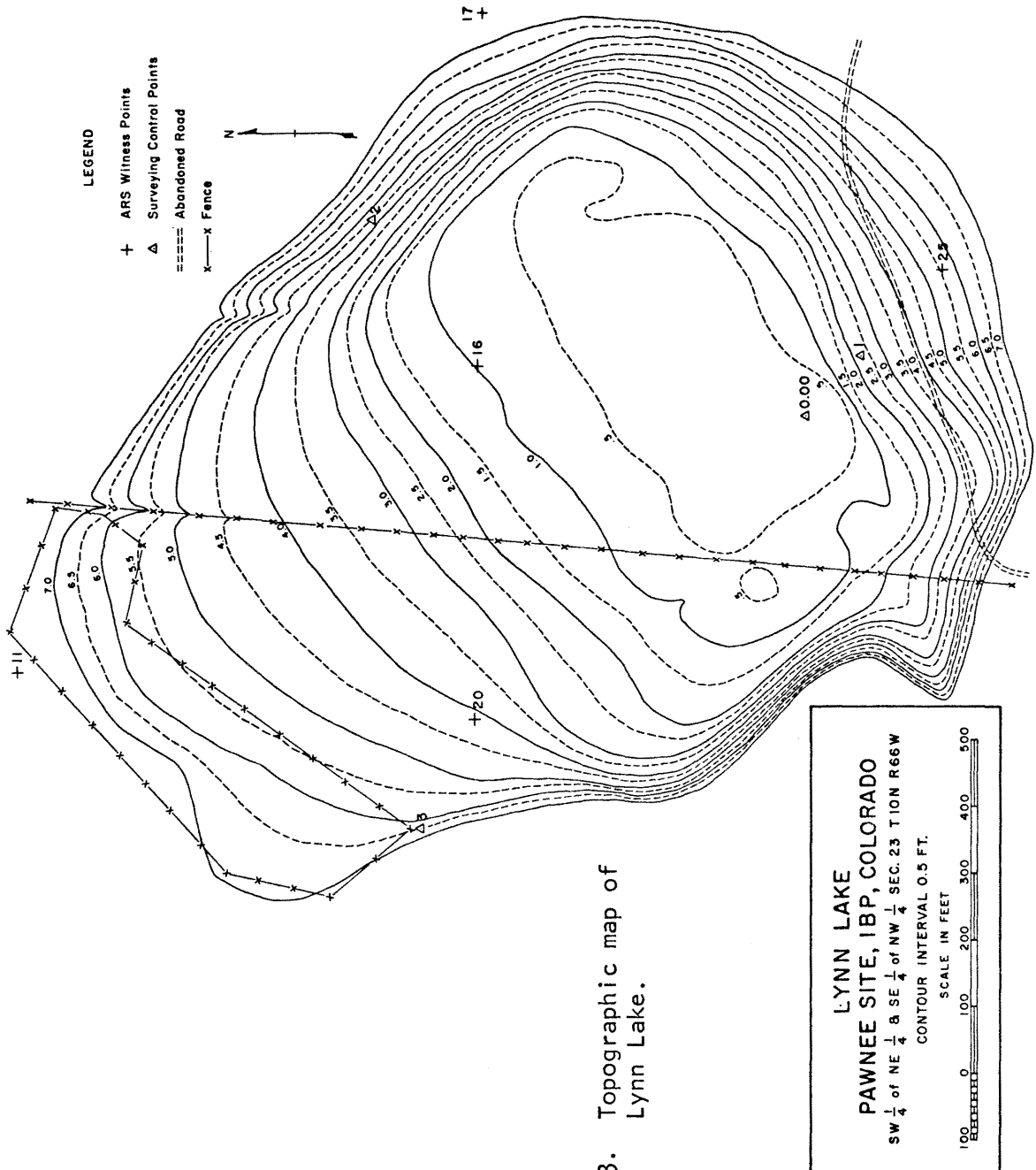

Figure 3.3. Topographic map of Lynn Lake.

Table 3.1. Soil type-area relationship for the
Lynn Lake watershed.

Soil Type	Area (hectares)	Area (acres)	% of total
Undifferentiated	38	94	9.4
Vona sandy loam	15	38	3.8
Ascalon sandy loam	247	611	60.9
Platner loam	0.4	1	0.1
Renohill sandy loam	35	87	8.7
Gravel bars	3	7	0.7
Shingle loam	15	37	3.7
Shingle-Renohill complex	52	128	12.7

are defined quantitatively on the basis of the amount of ungrazed herbage remaining on the pasture at the end of the grazing season (approximately October 15). For 1971, pasture use values were 397, 345, and 164 kg ha⁻¹ (354, 308, and 146 lbs. acre⁻¹) remaining herbage for the light, moderate, and heavy grazing, respectively.

Climate of the Pawnee Grasslands

In connection with the IBP Grasslands Biome project, Bertolin and Rasmussen (1969) and Rasmussen et al. (1971) used existing climatological data to describe the climatology of the Pawnee Grasslands. They conclude that precipitation variability (in time and in space) is probably the most outstanding characteristic of the grasslands climate. Eastern Colorado, wherein lies the Pawnee Grasslands, is characterized by a semiarid continental climate, generally having less than 380 mm (15 inches) of annual precipitation. Using the traditional classification scheme, this would be a cool steppe climate. The mean annual precipitation at the CPER station is 309 mm (12.2 inches) for some 30 years of data. May, June, July, and August tend to be the wettest months, in that order, all averaging at least 37.6 mm (1.5 inches) of precipitation. These four months usually account for more than 50% of the annual precipitation. In a regression analysis, Rasmussen et al. (1971) found that summer precipitation explained 89% of the variance in annual precipitation with winter precipitation accounting for only 11%. This is explained by the frequent occurrence of convective activity in the area in summer. Southwesterly flow of wetter gulf air combines with intense solar heating and orographic influence over the mountains to generate thunderstorms which move in an easterly

direction over the grasslands beginning around noon each day. The winter climate is dominated by the presence of continentally polar air masses, with very few storms moving over the area. Storms which pass over the Rocky Mountain region lose most of their moisture over the mountains; consequently, dry, sunny days are common in winter. The winter storms which do hit the area have little effect on the mean water balance of the region. This is so because high insolation, moderate to high winds, and warm daily air temperatures combine to sublimate much of the snow. Major storms, defined as greater than 2.54 cm (1.00 inch) of precipitation, account for 74% of the variance in summer precipitation and only 16% of the variance in winter precipitation. Storms greater than 1.27 cm (0.50 inch) have very little effect on yearly precipitation variability.

The large diurnal variation in air temperatures is another outstanding characteristic of the grasslands climate. Average diurnal variations are between 17 and 20°C (30 and 35°F), with variations up to 34°C (60°F) possible in late summer. Observed extreme temperatures for the Pawnee Grasslands are 40°C (105°F) and -34°C (-29°F). The lowest average monthly maximum temperature is 7°C (44°F) (January and December) for approximately 30 years of data. The highest average monthly maximum temperature is 31°C (88°F) (July). The lowest and highest average monthly temperatures are -12°C (11°F) (January) and 12°C (54°F) (July), respectively. The median frost-free period is 128 days.

Another important characteristic of grasslands climate is the presence of moderate to high winds throughout much of the year. The period December to May experiences noticeably higher winds than the

remaining months. This characteristic plays an important role in the redistribution of snow following winter storms and the resulting winter water balance of the region.

Historical Geology and Geomorphology

The Pawnee Grasslands are a part of the landfarm region known as the Colorado Piedmont, which is an erosion surface originating from the High Plains. The Chalk Bluffs to the north of the Pawnee Grasslands and the Pawnee Buttes to the east are remnants of the High Plains surface, which was once part of a peneplain originating in the Rockies to the West. Badaracco (1971) has provided an excellent geological history of the region. In an earlier publication, Dort (1959) discusses the geomorphological history of the southern Great Plains, including the High Plains and Colorado Piedmont regions. Approximately 50 to 100 million years ago (Cretaceous period), a shallow sea covered the region which is now the High Plains. Deposition of limestone, shale, sandstone, and conglomerate materials occurred. Some 50 million years later the ancestral Rocky Mountains were formed and the High Plains surface was raised above sea level. A cycle of erosion followed, whereby streams originating in the ancestral Rockies flowed over the plains surface, cutting stream channels and leaving a relief of several hundreds of feet. A change to a more arid climate then occurred; stream power diminished and deposition began, filling valley floors with silt, sand, and gravel. Deposition continued until relief was subdued considerably. Eastern Colorado today is a part of this depositional surface, which has been modified only slightly since its formation. We now are again in a period dominated by erosional processes; however, this erosional cycle is probably less severe than

previous erosional cycles. The Pawnee Site is said to lie over the old Cretaceous beds (Badaracco 1971). The knolls and ridgetops covered by shale- and siltstone-derived soils are probably remnants of the Cretaceous sea beds (Pierre formation). The swale bottoms, now covered with silt- and clay-sized material, have subsoils of very coarse material, owing to the periods of alluvial deposition. The influence of wind erosion and deposition cannot be overlooked. The entire area appears to have been covered recently by 5 to 15 cm of loessal material. In the past the region may have been worked over considerably by wind action. Indeed, many of the smaller depressions found on the present landscape may well represent deflation basins.

Soils of the Lynn Lake Watershed

Six major soil types, including four soil series, were studied intensively as part of this investigation. The differences in the soil series appear to relate to differences between their respective geologic parent materials. The Ascalon soil series, the most common soil found on the area, is derived from fluvial outwash materials of granitic sediment origin. This soil series occupies the lower slope positions adjacent to the swales. The predominant geologic formation of the area, the Pierre sedimentary formation, is responsible for the remaining three soil series. The Renohill and Shingle series are derived from shale and siltstone outcrops of the Pierre formation. Since the Renohill series is classified as a sandy loam soil, it is quite likely that sandstone outcrops associated with the Pierre formation contributed to the development of this series. These two soils series are often mapped together as a complex and, in fact, the Shingle-Renohill complex covers 12.7% of the Lynn Lake watershed area. The Shingle

and Renohill series and the Shingle-Renohill complex tend to occupy the middle and upper slope positions and the ridgetops. The exact origin of the Vona soil series is uncertain. Franklin (1969) suggests that it may have been formed either from coarse outwash material or from a Pierre sandstone outcrop. As with the Ascalon series, the Vona sandy loam occupies the lower slope positions. The sixth major soil type is mapped as an undifferentiated soil. It occupies the bottoms of the swales and essentially has an alluvial origin. Nearly all the soils have been subjected to recent aeolian deposits. Franklin (1969) found evidence of alluvial and/or colluvial removal of this loessal material on the steeper Shingle and Renohill soils, and consequent deposition on or mixing with the Ascalon and undifferentiated soils below.

Data on the physical and hydrologic properties of the six major soils are presented in reports by Franklin (1969) and Van Haveren and Galbraith (1971). These properties are summarized in Tables 3.2 and 3.3. Figures 3.4 through 3.9 represent desorption curves developed from the data of Table 3.3.

An analysis of variance test was run on the surface bulk density data (Galbraith and Van Haveren, unpublished data). A significant difference in bulk density was found between the heavy and light grazed soils. The interaction effect between soil type and grazing was highly significant, with the heavier soils and higher grazing intensities combining to give very high bulk density values. This finding has hydrologic significance since one of the heavy soils, the Shingle loam, is commonly found on the more steep upper slope positions. The greatest amount of compaction by animal traffic probably occurs in late spring and early summer or immediately after precipitation events, when the soil surface is wet.

Table 3.2. Summary of physical properties of the major soils, Pawnee Intensive Site.

Soil	Type No.	Mean Horizon Depth (cm)		Mean Surface Bulk Density (gm cm ⁻³)	Soil Texture A-horizon			Soil Texture B-horizon		
		A	B		Mean % Sand	Mean % Silt	Mean % Clay	Mean % Sand	Mean % Silt	Mean % Clay
Undifferentiated	47	0-15	15-53	1.41	62	17	21	65	12	23
Vona sandy loam	51	0-10	10-36	1.40	75	9	16	69	10	21
Ascalon sandy loam	55	0-15	15-46	1.42	69	14	17	60	15	25
Renohill sandy loam	66	0-15	15-41	1.39	64	14	22	51	17	32
Shingle loam	87B	0-13	13-46	1.38	65	16	19	56	22	22
Shingle-Renohill Complex	87Z	0-15	15-53	1.45	62	15	23	52	18	30

Table 3.3. Desorption characteristics of the major soils, Pawnee Intensive Site (Mean desorption data taken from laboratory analysis as described in Chapter IV).

Soil	Horizon	Applied Pressure, Bars						% H ₂ O by volume between 0.3 and 15.0 bars
		0.0	0.1	0.3	1.0	3.0	15.0	
Undifferentiated	A	66.0	48.0	28.8	25.2	15.5	13.9	14.9
	B	61.3	38.6	22.1	18.7	11.7	9.9	12.2
Vona sandy loam	A	60.2	33.3	17.3	14.0	8.7	7.4	9.9
	B	61.4	33.8	19.5	16.4	10.7	9.4	10.1
Ascalon sandy loam	A	65.2	45.9	20.0	16.2	10.0	9.0	11.0
	B	65.3	43.2	24.4	20.4	12.9	11.7	12.7
Renohill sandy loam	A	57.2	34.2	17.1	15.0	10.3	9.9	7.2
	B	67.6	46.4	27.6	24.5	15.3	13.4	14.2
Shingle loam	A	59.8	35.9	22.2	20.0	11.9	11.1	11.1
	B	62.9	45.0	25.5	22.1	11.9	11.0	14.5
Shingle-Renohill Complex	A	57.2	37.4	23.9	21.3	13.7	12.9	11.0
	B	63.7	41.9	26.2	23.8	15.0	13.7	12.5

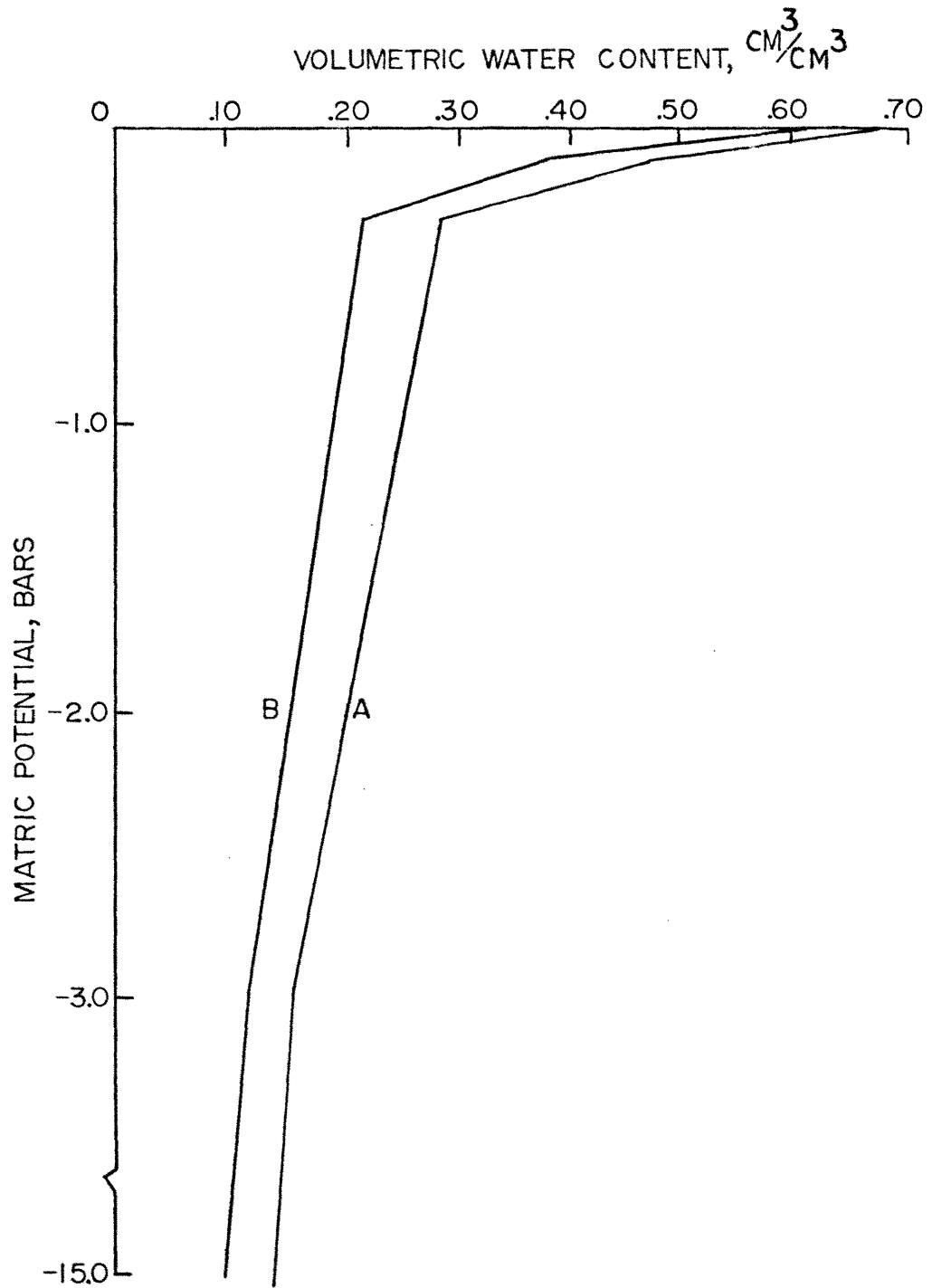

Figure 3.4. Desorption curve for undifferentiated soil.

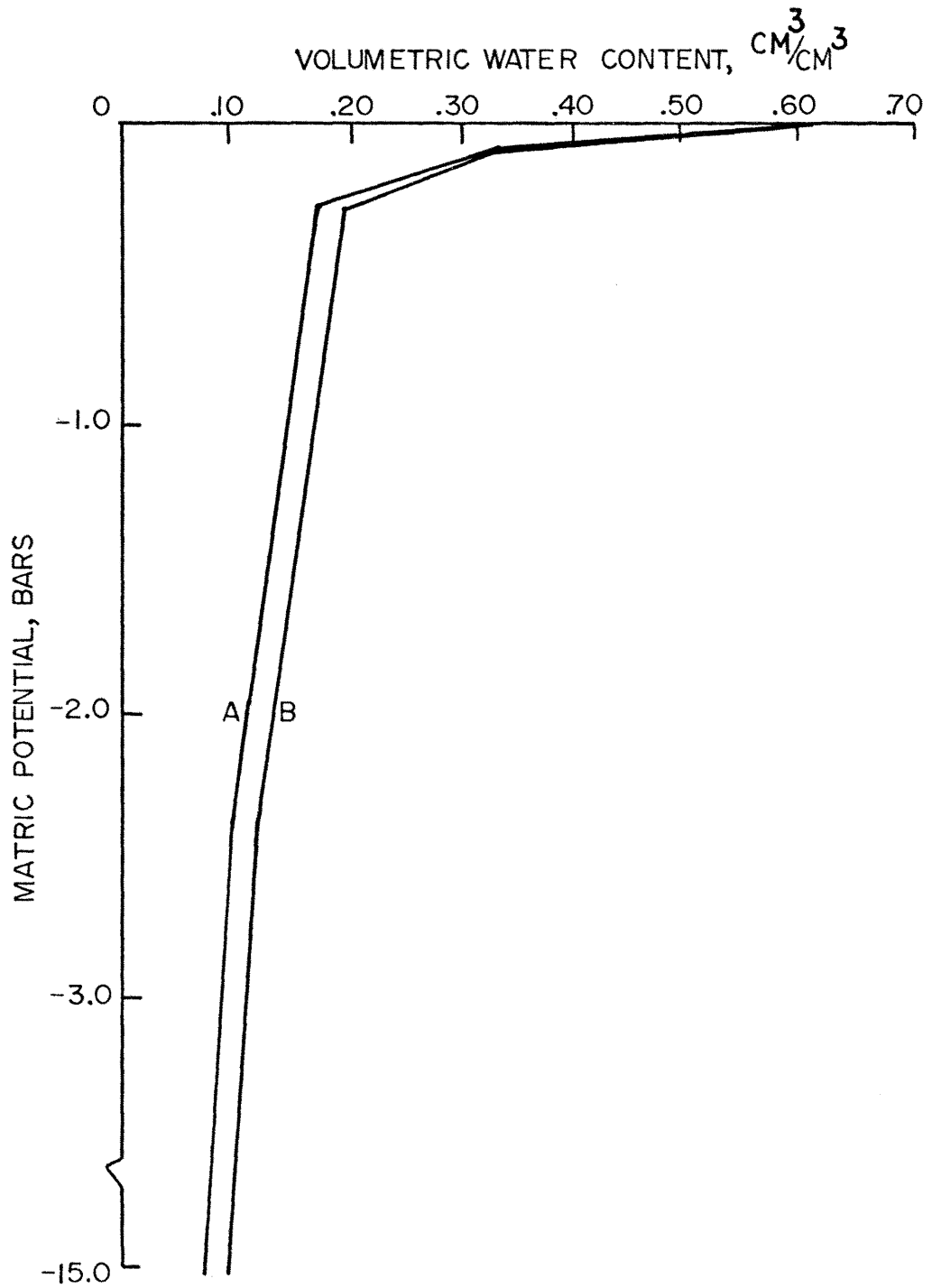

Figure 3.5. Desorption curve for Vona sandy loam.

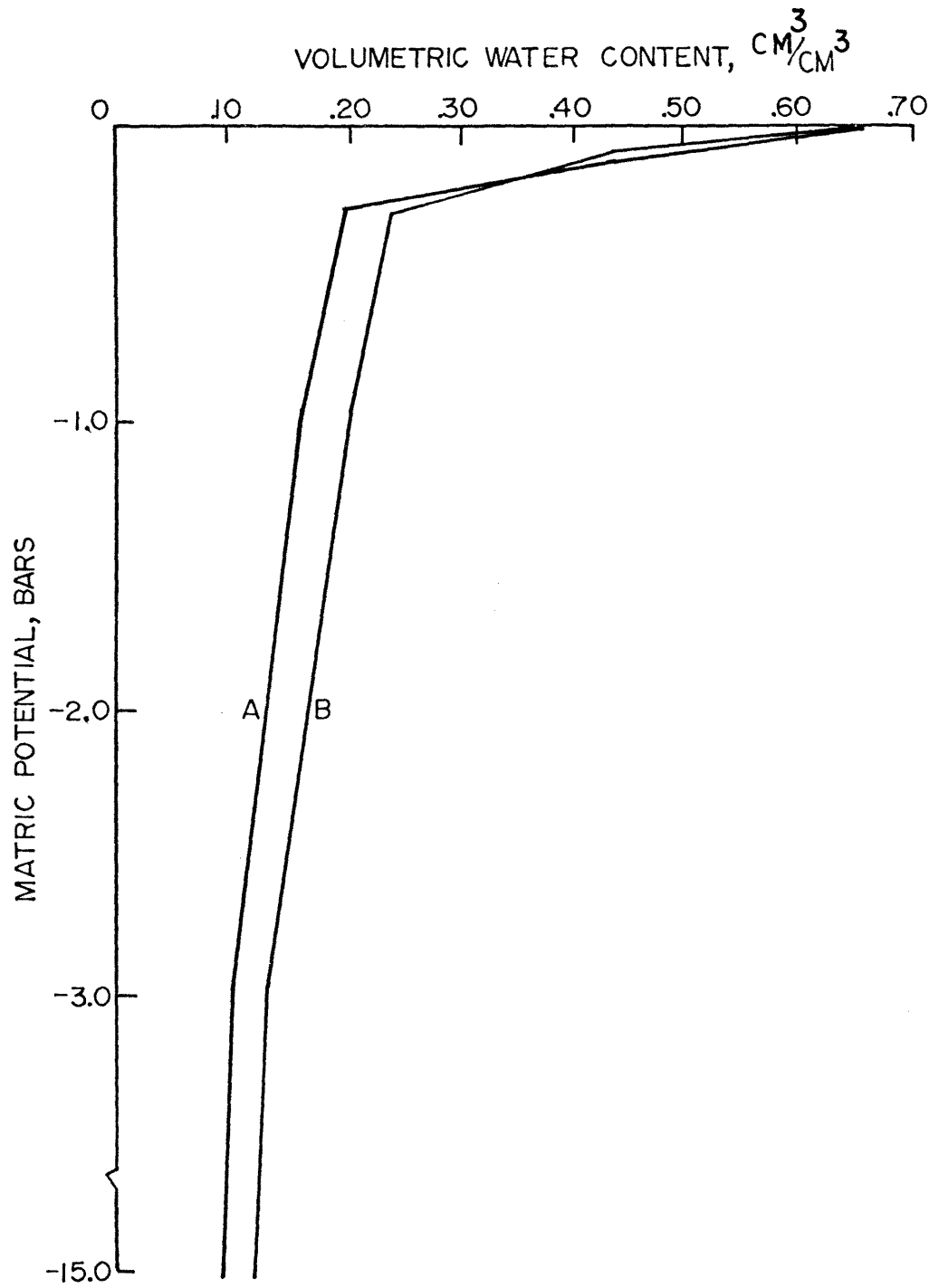

Figure 3.6. Desorption curve for Ascalon sandy loam.

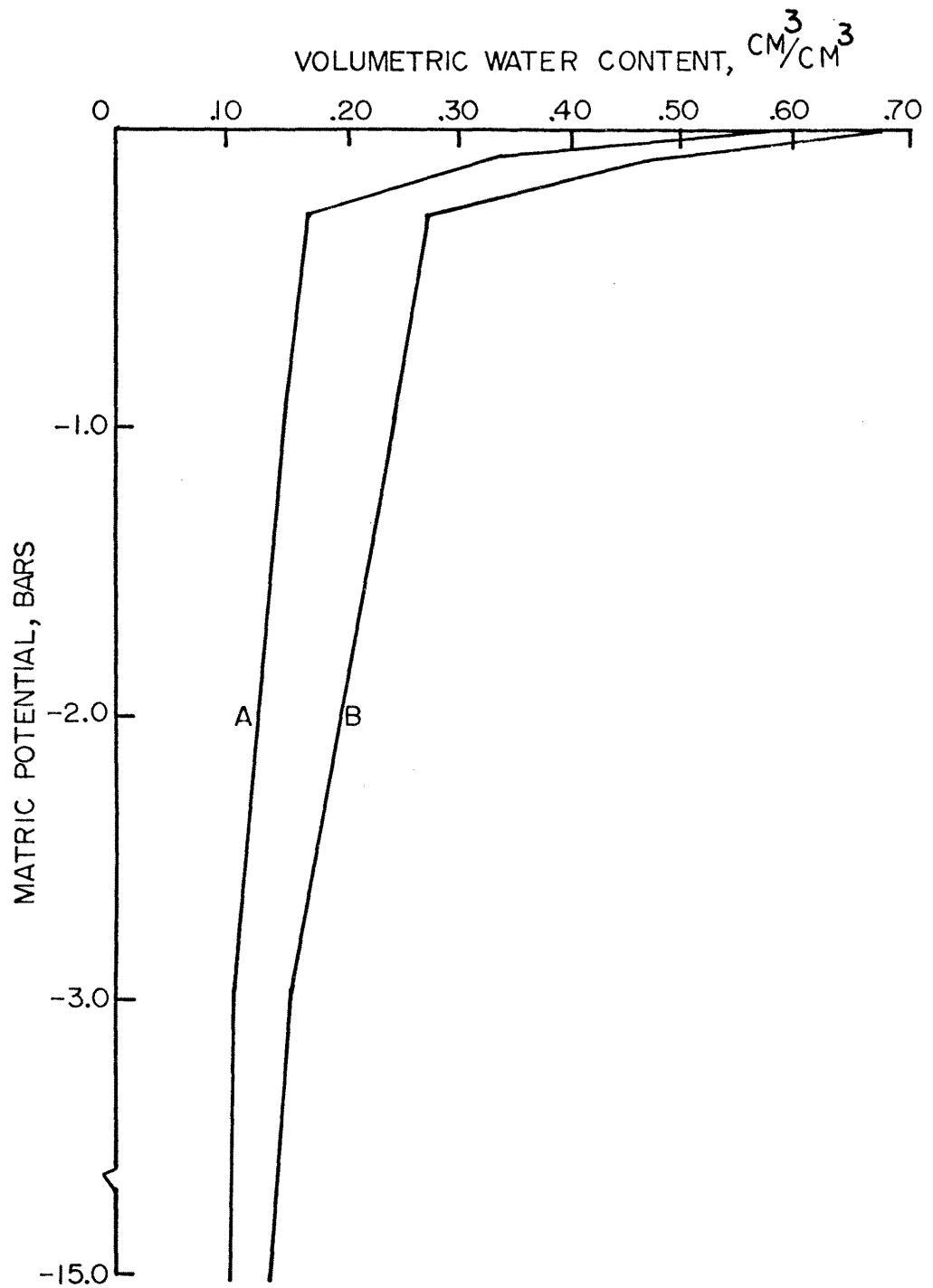

Figure 3.7. Desorption curve for Renohill sandy loam.

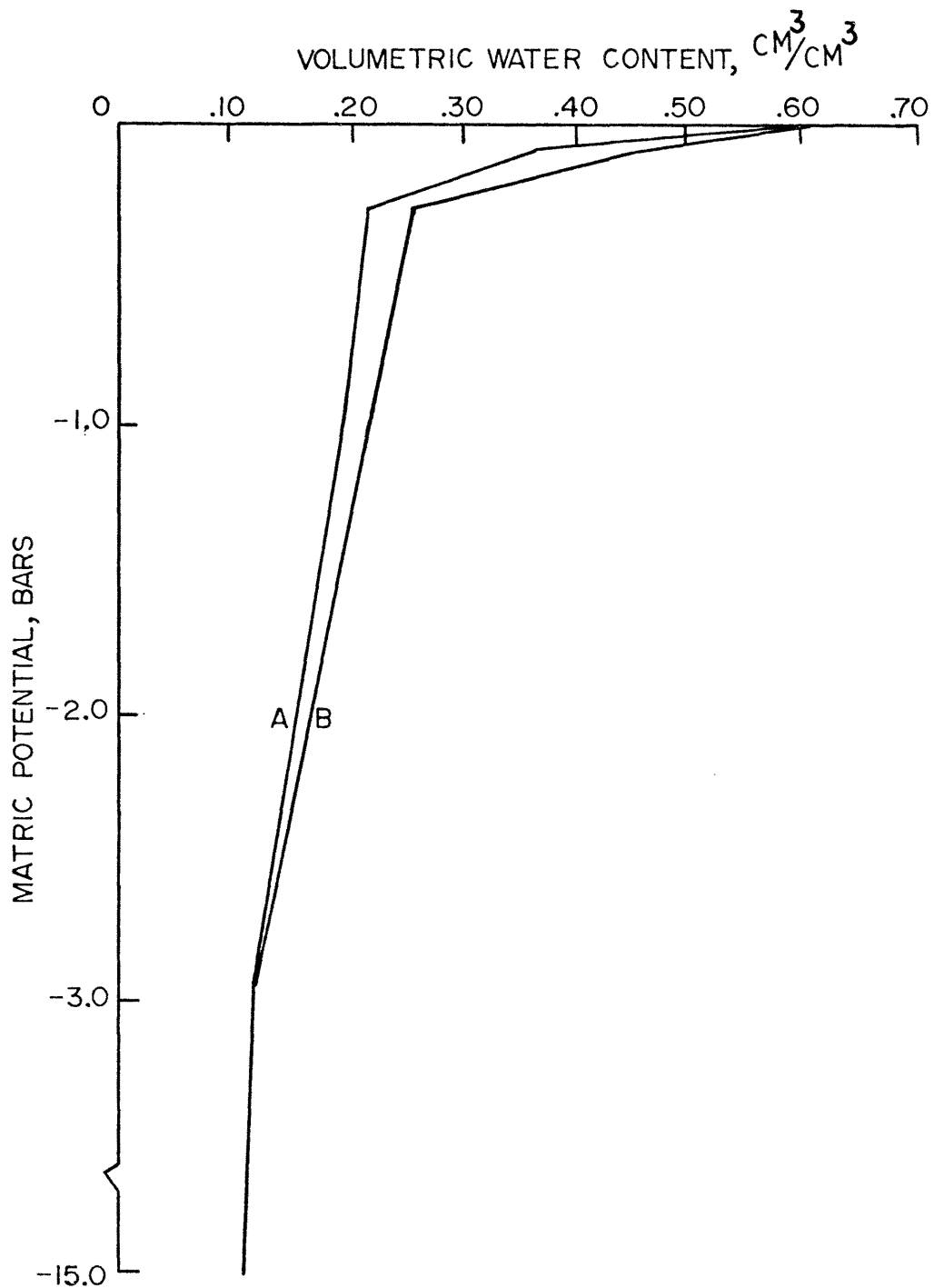

Figure 3.8. Desorption curve for Shingle loam.

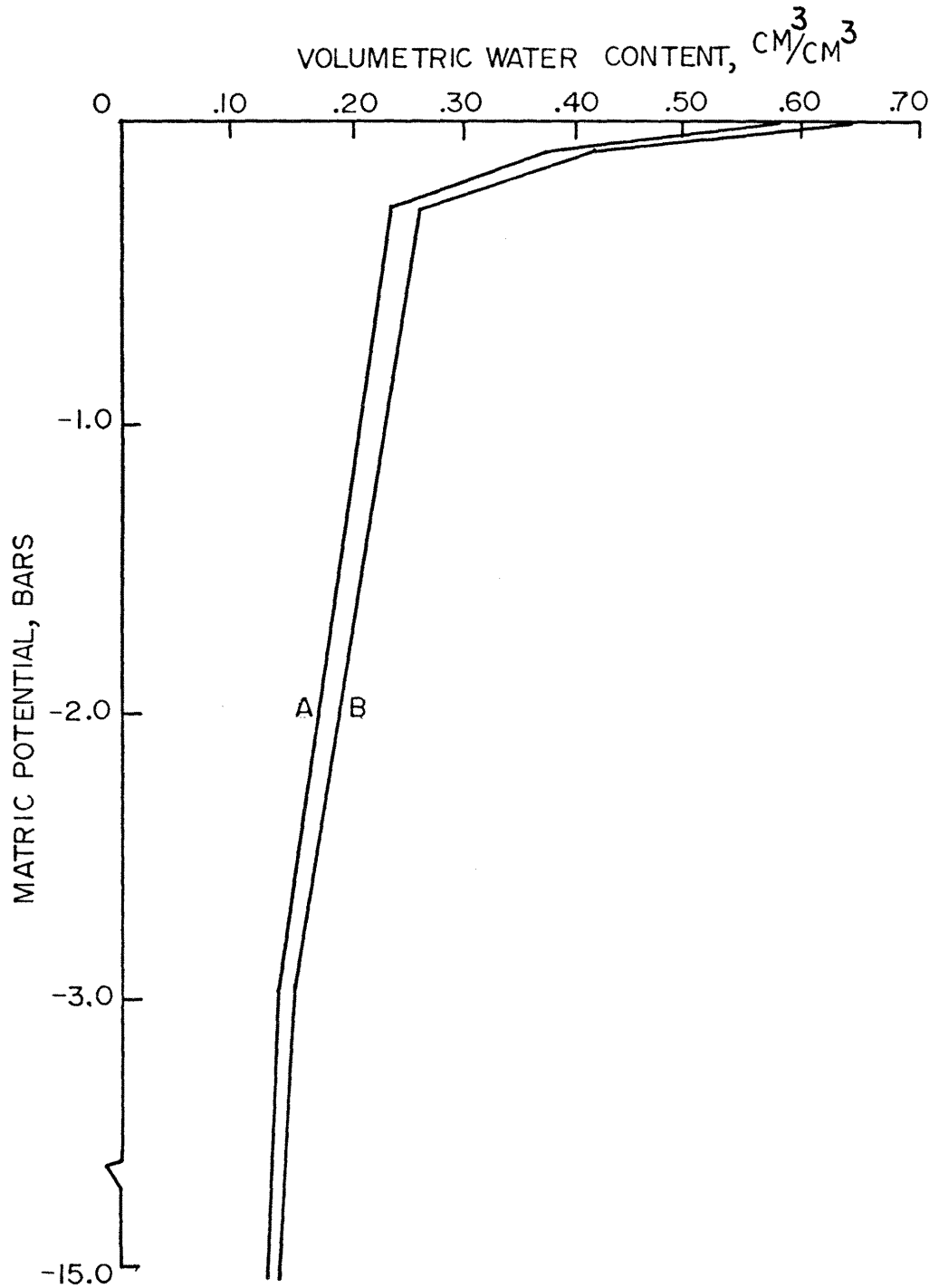

Figure 3.9. Desorption curve for Shingle-Renohill Complex.

The desorption data appear to reflect the differences in soil texture between the six soils. The water-holding capacities differ substantially between horizons for the undifferentiated, Ascalon, and Renohill soils. Considering both the A and B horizons, the undifferentiated soil and the Shingle loam have the highest water-holding capacities of the six soils. The Renohill sandy loam is probably the most interesting from a hydrologic standpoint of all the soils found on the Pawnee Site. The amount of water held between 0.3 and 15.0 bars is only 7% by volume for the A horizon. The B horizon is considerably higher--14% by volume. These conditions are probably responsible for the fact that Renohill sandy loam is often associated with the more mesic sites on the Pawnee Grassland, and often characterized by the presence of midgrasses.

Vegetation of the Pawnee Site

Jameson (1969) lists common grasses, forbs, and browse species found on the Pawnee Site. Shaver and Fisser (1972) developed the vegetation map shown as Figure 3.10 (back pocket). An extensive field plant list was developed by Dickinson and Baker (1972).

The area is typically native shortgrass prairie, characterized by blue grama (*Bouteloua gracilis* (H.B.K.) Lag.), buffalo grass (*Buchloe dactyloides* (Nutt.) Engelm.), and supplemented by threadleaf sedge (*Carex filifolia* Nutt.) and needle leaf sedge (*Carex eleocharis* Bailey). On the more mesic sites, particularly in the lightly and moderately grazed pastures, certain midgrasses associate with the shortgrasses. These are western wheatgrass (*Agropyron smithii* Rydb.), needle-and-thread (*Stipa comata* Trin. and Rupr.), green needlegrass (*Stipa viridula* Trin.), little bluestem (*Andropogon scoparius* Michx.), side-oats grama

(*Bouteloua curtipendula* (Michx.) Torr.), and red threeawn (*Aristida longiseta* Stfud.). *Opuntia polyacantha* Haw., the plains pricklypear cactus is found throughout the site, increasing with grazing pressure. Purple mammillaria or pincushion cactus (*Coryphantha vivipara* (Nutt.) Haw.) is occasionally seen. Sun sedge (*Carex heliophila* Mackenz.) is common in the swale bottoms. Common shrubs include fringed sagewort (*Artemisia frifida* Willd.), fourwing saltbush (*Atriplex canescens* (Pursh.) Nutt.), winterfat (*Eurotia lanata* (Pursh.) Moq.), and broom snakeweed (*Gutierrizia sarothrae* (Pursh) Britt. and Rusby).

Leaf area dynamics have been studied on the Pawnee Site by Knight (1971, 1972). Knight (1971) also reported on vegetation height data collected on the microwatersheds, and found differences in mean vegetation height which were related to grazing pressure. Heavily-grazed conditions resulted in a vegetation height half that of ungrazed vegetation. Galbraith (1971) felt that the reduced vegetation height resulted in less snow retention and reduced evapotranspiration for the heavily-grazed pasture. For both field seasons 1970 and 1971, Knight found that the total green leaf area index (LAI) was remarkably uniform across grazing treatments.

CHAPTER IV

EXPERIMENTAL DESIGN, METHODS, AND INSTRUMENTATION

But first I shall test by experiment before I proceed further, because my intention is to consult experience first and then with reasoning show why such experience is bound to operate in such a way.

Leonardo da Vinci

The soil water study was concentrated on three straightline sampling transects. Each transect represents a different grazing treatment: heavy summer, moderate summer, and light summer. As shown in Figure 4.1, the summer-grazed sampling transects are all located in the central basin watershed and are oriented perpendicular to the main axis of the drainage.

Sampling points, spaced 25 m apart, were chosen for each of the transects. Soils data were reviewed to determine representativeness of each sampling point. Final sampling points, approximately 20 per transect, were chosen so that all combinations of grazing treatment, soil type, and "position-on-slope" were represented. Characteristics of each sampling point are given in Table 4.1. The sampling design is shown in Table 4.2a-d. During the summer of 1970 a neutron probe access tube was installed at each sampling point and the A-, B-, and C-horizons were sampled for bulk density, texture, and water retention properties. Topographic profiles of the sampling transects are included as Appendix A.

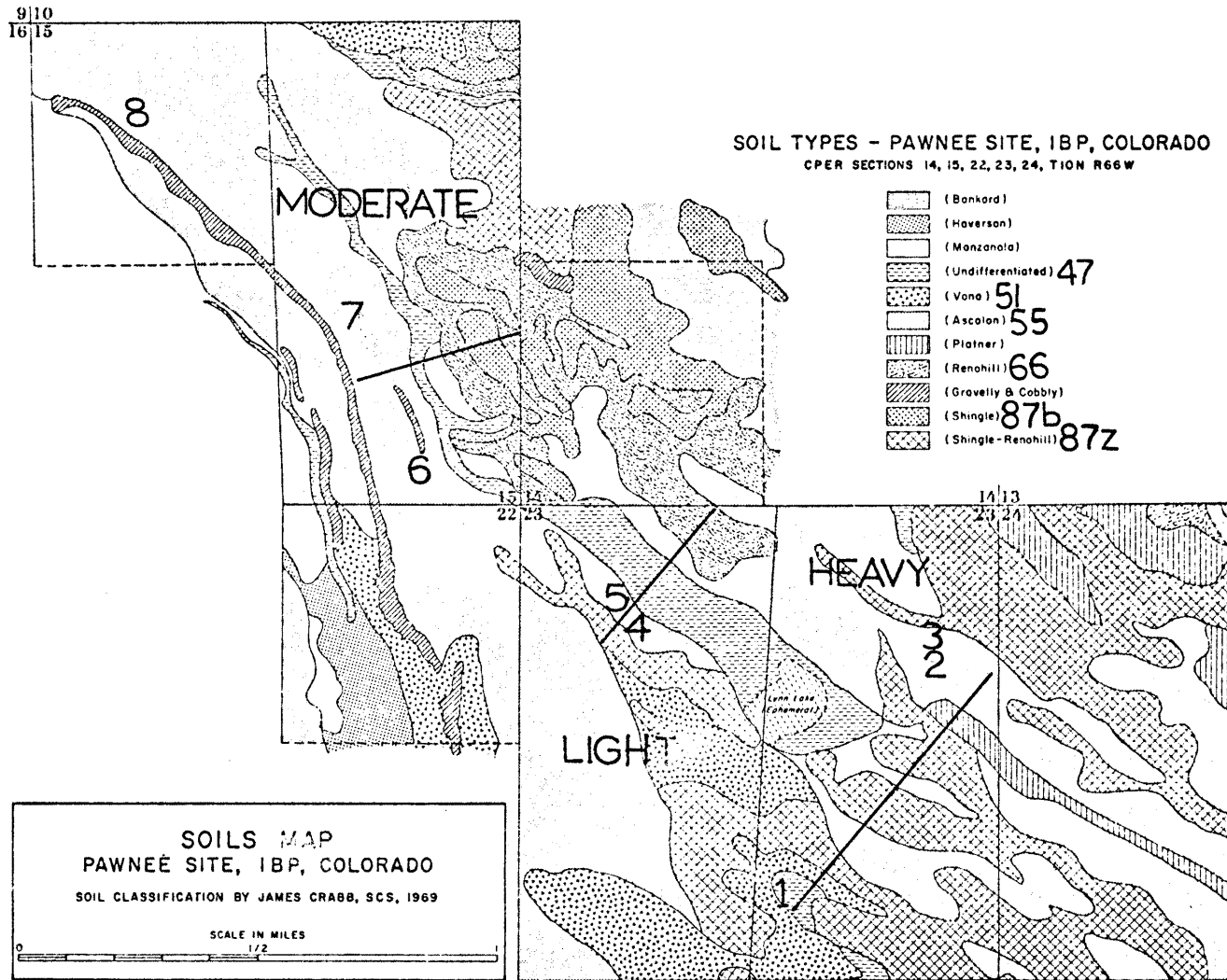

Figure 4.1. Soils map of the intensively used pastures in the Lynn Lake watershed, showing the eight microwatersheds and three sampling transects.

Soil Sampling Methods and Laboratory Analysis Techniques

The field sampling procedure for obtaining bulk density, textural, and water retention samples was identical to that described by Galbraith (1971). The sample sizes for the three types of samples were, respectively, 50, 100, and 50 cm³. Sand, silt, and clay fractions were determined using the hydrometer method (Day 1965). The pressure plate method (Richards 1965) was used to determine desorption characteristics. Samples were subjected to applied pressures of 0.0, 0.1, 0.3, 1.0, 3.0, and 15.0 bars.

Soil Water Content Measurement

Volumetric soil water content was obtained with Nuclear Chicago neutron probes, having Americium²⁴¹-Beryllium sources. Battery-powered portable scalers were used to measure the neutron flux detected by the probe. Both the neutron probes used in this study were calibrated by Galbraith (1971) in the Ascalon sandy loam soil on the Pawnee Site during the 1970 field season. Since the other soils investigated in this study were sandy loams or loams, it was thought that the initial calibration would be valid for use in these soils. Douglass (1966), investigating the effect of soil texture on count rates, found no significant difference among four closely related soil types.

The access tubes on the soil water transects were installed to a depth of 1.5 m. Five tubes were installed to depths ranging from 2.1 to 3.0 m. Sampling depths included the 15, 30, 45, 60, 75, 90, 120, and 150 cm depths, and, where appropriate, the 180, 210, 240, 270, and 300 cm depths.

Table 4.1. Characteristics of the sampling points on the soil water transects.

Transect	Sample Point	Grazing Intensity	Soil Type	% Slope	Aspect (azimuth)	Position on Slope
1	1	Heavy	55	2.0	210	Top
1	2	Heavy	55	4.5	210	Mid 1/3
1	3	Heavy	47	0.0	290	Bottom
1	4	Heavy	47	1.5	20	Bottom
1	5	Heavy	87z	3.0	30	Mid 1/3
1	6	Heavy	87z	6.5	320	Mid 1/3
1	7	Heavy	87z	4.0	300	Upper 1/3
1	8	Heavy	87z	3.0	280	Upper 1/3
1	9	Heavy	55	3.0	320	Mid 1/3
1	10	Heavy	87z	2.5	340	Mid 1/3
1	11	Heavy	87z	0.5	340	Top
1	12	Heavy	87z	7.0	190	Upper 1/3
1	13	Heavy	87z	7.0	200	Lower 1/3
1	14	Heavy	55	0.0	310	Bottom
1	15	Heavy	55	0.0	300	Bottom
1	16	Heavy	55	0.0	320	Bottom
1	17	Heavy	55	0.5	10	Bottom
1	18	Heavy	87z	2.0	20	Mid 1/3
1	19	Heavy	87z	1.0	50	Upper 1/3
1	20	Heavy	51	0.5	150	Mid 1/3
1	21	Heavy	51	1.0	310	Mid 1/3
1	22	Heavy	51	0.5	340	Mid 1/3

Transect	Sample Point	Grazing Intensity	Soil Type	% Slope	Aspect (azimuth)	Position on Slope
2	1	Light	66	4.0	115	Top
2	2	Light	66	5.0	205	Upper 1/3
2	3	Light	66	7.0	200	Upper 1/3
2	4	Light	66	8.5	205	Mid 1/3
2	5	Light	66	9.0	210	Mid 1/3
2	6	Light	55	6.0	185	Lower 1/3
2	7	Light	55	5.0	180	Lower 1/3
2	8	Light	47	1.0	125	Bottom
2	9	Light	47	1.0	120	Bottom
2	10	Light	47	0.0	120	Bottom
2	11	Light	47	0.0	115	Bottom
2	12	Light	47	0.0	155	Bottom
2	13	Light	47	0.0	40	Bottom
2	14	Light	55	4.0	20	Lower 1/3
2	15	Light	55	5.0	30	Lower 1/3
2	16	Light	55	7.0	30	Mid 1/3
2	17	Light	55	9.0	30	Upper 1/3
2	18	Light	87z	9.0	45	Upper 1/3
2	19	Light	87z	0.0	15	Top
3	1	Medium	55	0.0	240	Top
3	2	Medium	55	2.0	60	Upper 1/3
3	3	Medium	55	2.0	65	Upper 1/3
3	4	Medium	55	5.0	55	Mid 1/3
3	5	Medium	55	6.0	55	Lower 1/3

Transect	Sample Point	Grazing Intensity	Soil Type	% Slope	Aspect (azimuth)	Position on Slope
3	6	Medium	55	4.0	55	Lower 1/3
3	7	Medium	47	1.0	150	Bottom
3	8	Medium	47	2.0	245	Bottom
3	9	Medium	55	1.0	315	Lower 1/3
3	10	Medium	66	6.0	220	Lower 1/3
3	11	Medium	66	8.0	220	Lower 1/3
3	12	Medium	66	9.0	215	Mid 1/3
3	13	Medium	87b	11.0	210	Mid 1/3
3	14	Medium	87b	10.0	215	Upper 1/3
3	15	Medium	87b	7.0	205	Upper 1/3
3	16	Medium	87b	4.5	190	Top
3	17	Medium	66	4.0	65	Top
3	18	Medium	66	1.0	35	Top
3	19	Medium	47	1.5	180	Bottom

Table 4.2a. Sampling design of the soil water transects
(grazing treatment X slope position).

Slope Position	Grazing Treatment			
	Light	Medium	Heavy	
(number of sampling points)				
Top	2	4	2	8
Upper 1/3	4	4	4	12
Mid 1/3	3	3	9	15
Lower 1/3	4	5	1	10
Bottom	6	3	6	15
	19	19	22	60

Table 4.2b. Sampling design of the soil water transects
(grazing treatment X soil type).

Soil Type	Grazing Treatment			
	Light	Medium	Heavy	
	(number of sampling points)			
47	6	3	2	11
51	0	0	3	3
55	6	7	7	20
66	5	5	0	10
87b	0	4	0	4
87z	2	0	10	12
	19	19	22	60

Table 4.2c. Sampling design of the soil water transects
(grazing treatment X aspect).

Aspect	Azimuth	Numerical Rank	Grazing Treatment			
			Light (number of sampling points)	Medium	Heavy	
NW→N	315 to 360°	1	7	1	10	18
N→NE	0 to 45°					
NE→S55E	45 to 125°	2	4	6	1	11
S60W→NW	240 to 315°	3	0	3	6	9
S55E→S60W	125 to 240°	4	8	9	5	22
			19	19	22	60

Table 4.2d. Sampling design of the soil water transects
(grazing treatment X exposure).

Exposure	Azimuth	Numerical Rank	Grazing Treatment			
			Light (number of sampling points)	Medium	Heavy	
SW→NE	225 to 45° (windward)	1	6	4	16	26
NE→SW	45 to 225° (leeward)	2	13	15	6	34
			19	19	22	60

Soil water content sampling was begun during August, 1970, and continued on a monthly basis through May, 1971. Beginning with the 1971 growing season, weekly sampling intervals were attempted. Weekly samples were obtained throughout the growing season, except for a few weeks in May and early June when equipment failures occurred.

Soil Water Potential Measurement

Forty ceramic cup thermocouple psychrometers, purchased from Wescor, Incorporated, Logan, Utah, were slightly modified for use in the soil-water relations study. The principles of operation were covered adequately by Brown (1970); a brief review of these principles will suffice here.

Basically, the thermocouple psychrometer is a thermoelectric wet-bulb sensor. Referring to Figure 4.2, the copper-constantan and copper-chromel junctions act as twin reference junctions, remaining always at ambient temperature within the Teflon plug. The minute chromel-constantan sensing junction is housed within a protective ceramic cup. A 26 A.W.G. copper-constantan thermocouple is cemented to the outside of the psychrometer below the ceramic cup.

A Keithley Model 155 Null Point Microvoltmeter was used to read the output from both the thermocouple psychrometer and the copper-constantan thermocouple. A switchbox, consisting of a 1.35 V battery, a "cooling" circuit, and a "bucking voltage" circuit was connected to the input terminals on the microvoltmeter. The psychrometer leads in turn were connected to input terminals on the switchbox. The "cooling" circuitry allows the investigator to reverse polarity of the thermocouple psychrometer circuit and apply a current of approximately 5 ma.

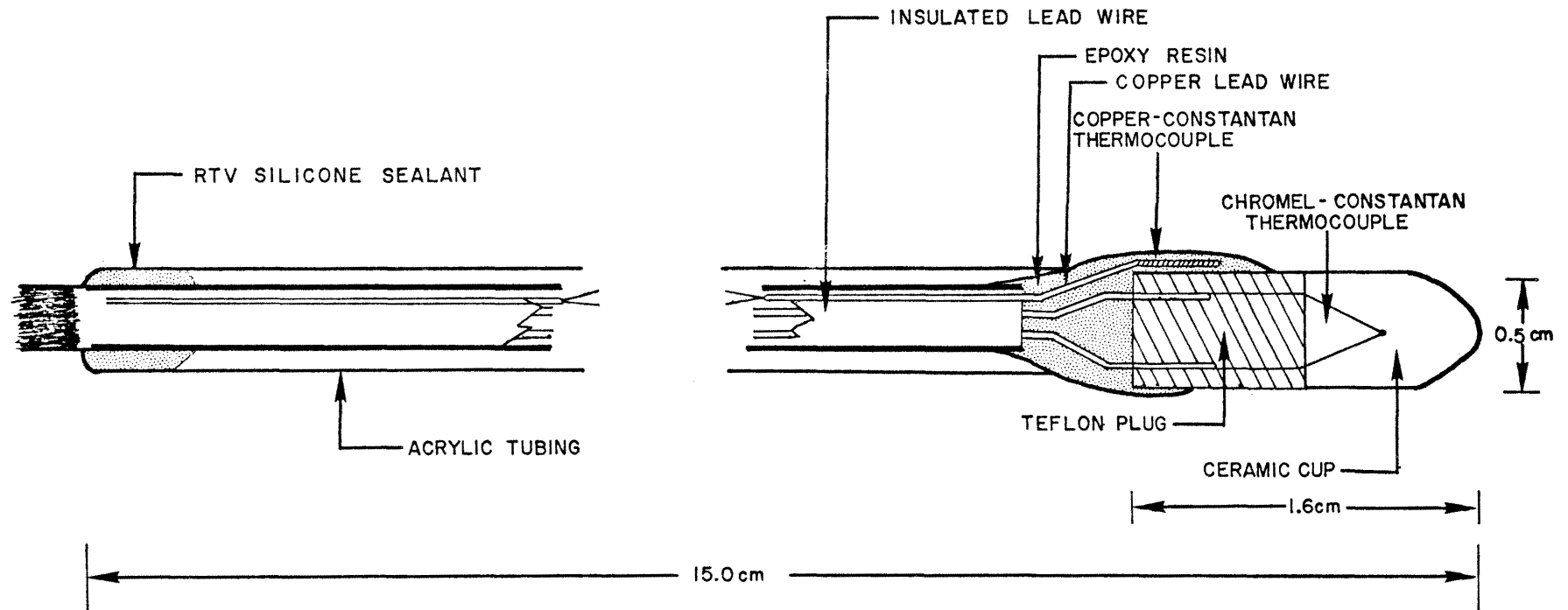

Figure 4.2. Diagram of thermocouple psychrometer probe used in the study.

Because of the Peltier effect, this current results in a cooling of the chromel-constantan sensing junction. With chromel-constantan thermocouple junctions, a maximum temperature depression of only 0.6°C is possible. Thus, the thermocouple psychrometer described here is limited to use in atmospheres having a relative humidity greater than 90%. Under high humidity conditions, then, water may be condensed on the chromel-constantan junction, if sufficient cooling results in the junction reaching the dewpoint. The length of the cooling period required to produce condensation is a function of the humidity of the atmosphere. At the end of this cooling period, the circuitry is returned to the reading position. A "reading" is taken where the microvolt signal (between 0 and $30\mu\text{V}$) reaches a steady state, corresponding to the wet-bulb temperature. Cooling times and measuring procedures used in the laboratory calibration were duplicated in the field so as to achieve consistency between calibration and actual use. The copper-constantan thermocouple, used to measure soil temperature at the psychrometer chamber, was read with the same equipment described above. The switchbox included a 0°C referencing circuit so that the output signal (0 to 2 mV) could be converted directly to temperature using conventional copper-constantan thermocouple tables.

Psychrometer calibration. The 40 commercial units were calibrated following a rigorous procedure suggested by Meyn and White (1972). In their study, a predictive model of thermocouple psychrometer behavior was developed using a multiple regression approach. Using their technique, each psychrometer is subjected to numerous water potential-temperature combinations. Water potential is controlled with the use of NaCl solutions (KCl may also be used) of varying concentrations.

Usually three measurements (replicates) are taken at each water potential-temperature combination. The resulting data are pooled and run through a multiple regression analysis. In the present study, all forty soil psychrometers were calibrated at nine combinations of water potential and temperature. Table 4.3 gives the calibration solution molarity, calibration temperature, and resulting water potential of the NaCl solutions used.

In the multiple regression analysis, STAT38R, a stepwise-accretion multiple regression program developed by the CSU Statistical Laboratory, was used. Water potential of the solution was made the dependent variable and microvolt output, temperature, (microvolts)², (temperature)², and (microvolts x temperature) were used as independent variables. The following regression summary was obtained:

Step	Variable Entered	R ²	Std. Error of Estimate (bars)
1	Microvolts	0.91305	4.47
2	(Microvolts x Temperature)	0.97691	2.31
3	(Microvolts) ²	0.97738	2.29
4	(Temperature) ²	0.97747	2.28
5	Temperature	0.97756	2.28

The model resulting from this regression analysis is

$$\hat{Y} = -1.42985 - 3.90660 X_2 + 0.10162 X_3 - 0.01092 X_4 - 0.00442 X_5 + 0.08689 X_6 \quad [4.1]$$

Table 4.3. Water potentials (in bars) of different NaCl solutions for different temperature ranges.

NaCl Molarity	Temperature Range °C		
	5-8	15-17	23-27
0.1	4.3-4.4	4.5	4.6
0.5	21.1-21.4	22.0-22.2	22.7-23.0
1.0	42.7-43.3	44.6-44.9	46.0-46.8

where

$$\hat{Y} = \text{water potential, bars;}$$

$$X_2 = \text{microvolt output, } \mu\text{V;}$$

$$X_3 = \text{temperature, } ^\circ\text{C;}$$

$$X_4 = (\text{microvolt output})^2, (\mu\text{V})^2;$$

$$X_5 = (\text{temperature})^2, (^\circ\text{C})^2;$$

$$X_6 = (\text{microvolts} \times \text{temperature}), (\mu\text{V} \times ^\circ\text{C}).$$

A reliable easy-to-use model may be obtained from the regression analysis above by eliminating variables X_3 , X_4 , and X_5 . The following model, having an R^2 of 0.977 and standard error of estimate of 2.3 bars, was used to convert raw field psychrometer data to soil water potential values:

$$\hat{Y} = -0.77246 - 3.93914 X_2 + 0.07790 X_6, \quad [4.2]$$

where the variables are the same as defined above.

With the use of the stepwise multiple regression computer program (STAT38R), the inverse of the corrected sums of squares and cross-products matrix was computed. This matrix was used in computing confidence intervals for \hat{Y} at specified values of microvolt output and temperature. The confidence interval approach was thought to be a logical extension of the procedure developed by Meyn and White (1972). Confidence regions are deemed desirable for any hydrologic variable which has statistical sampling properties (Yevjevich 1972). The equation used to compute confidence intervals for the predicted soil water potential, \hat{Y} , was obtained from Mr. Tom Copenhaver of the CSU Statistical Laboratory, and is given as:

$$\hat{Y} \pm \sqrt{3} \sqrt{\frac{\sigma^2}{F(a, b)} (1 + \sqrt{X_0^2 C X_0})}, \quad [4.3]$$

where a represents the degrees of freedom due to regression and b is the df due to the residual mean square, $\hat{\sigma}^2$; X_0 is the vector of regression coefficients, and C is the $(X'X)^{-1}$ or uncorrected sums of squares and cross-products matrix. A computer program which calculated confidence intervals from equation [4.3] was obtained from the CSU Statistical Laboratory and revised for use in this study. This program, entitled CONFIDE, is presented in Appendix D along with a sample page of output.

Field installation of soil psychrometers. Following calibration, each unit was cemented into an acrylic tube, 13 cm long and 1.3 cm outside diameter (Figure 4.2). The purpose of the tubing was mainly to adapt the psychrometers so as to be compatible with access pipes used for field installation of the psychrometers. Figure 4.3 shows the design of this installation. The access pipes were made of plastic (PVC) sewer pipe, 75 cm long by 15 cm I.D. with walls of 3 mm thickness. Five 0.5-inch holes were drilled in each pipe at points corresponding to the predetermined measuring depths of 2, 10, 20, 40, and 60 cm. Eight locations along the medium-grazed transect were selected as sampling points; these locations corresponded with the sites of neutron probe access tube numbers 3, 5, 7, 8, 11, 14, 16, and 18. Vertical holes, 15 cm in diameter and 75 cm deep were augered approximately 45 cm from the respective neutron probe access tubes. The access pipes were then placed in the ground so that the psychrometer probe holes in the pipe faced the neutron probe access tube. Working from the half-inch holes pre-drilled in the access pipes, horizontal holes, designed to accommodate the psychrometer probes, were augered in the soil with a modified half-inch diameter drill bit (wood bit). The psychrometer

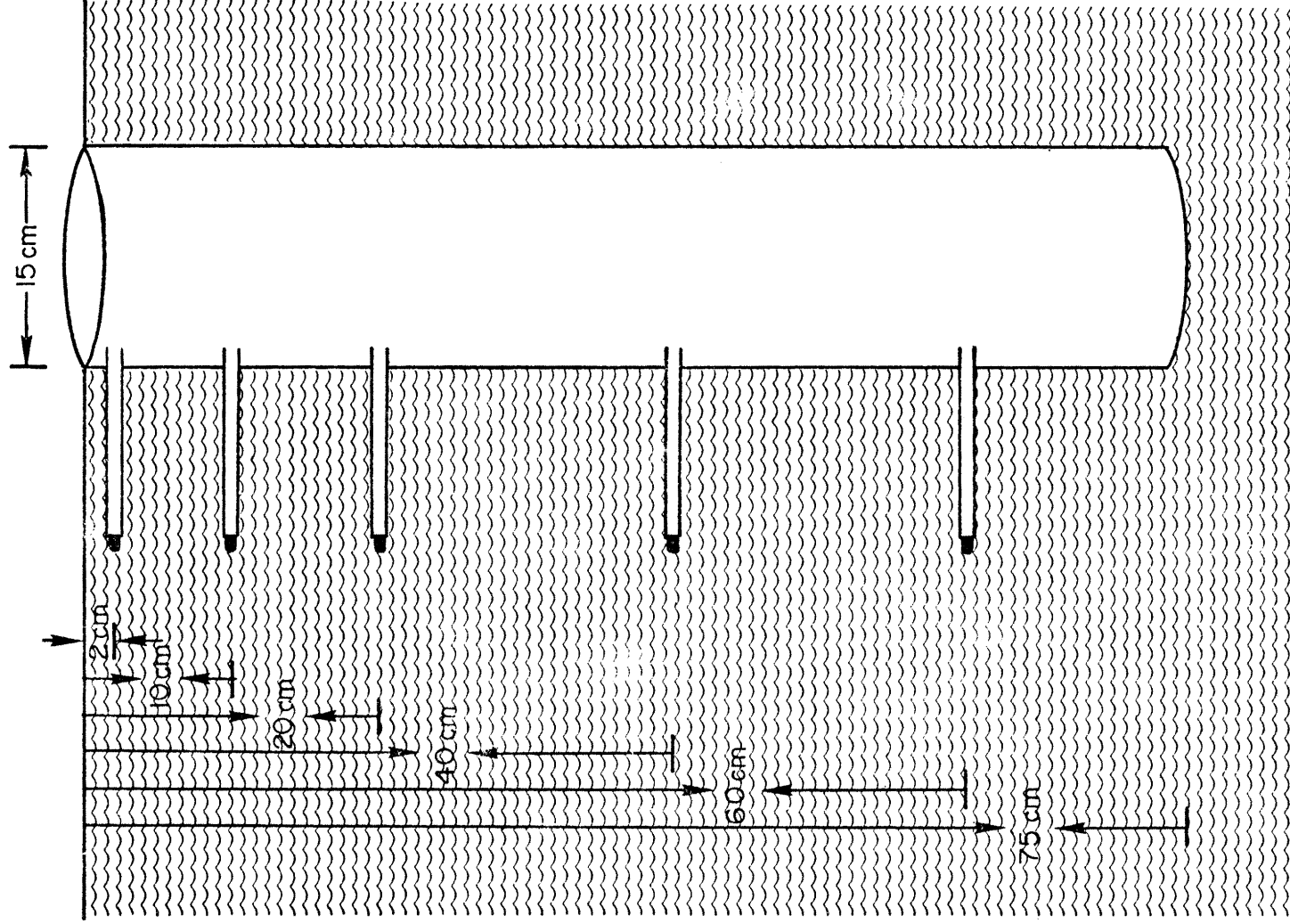

Figure 4.3. Design of psychrometer field installation.

probes were then inserted in these holes and sealed with silicone rubber sealant. After all five psychrometer probes were installed, the access pipe was filled with plastic bags of soil and then capped with a two-inch plug of styrofoam followed by a plastic cover.

The experimental design of this study was such that soil water potential was monitored at five depths on all four of the soil types found on the medium-grazed transect, with each soil type replicated once. The psychrometers were read on a weekly basis during May, June, and July. By the last week of July nearly all the psychrometers indicated soil water potential values too low (< -70 bars) to be accurately monitored.

CHAPTER V

STATISTICAL ANALYSIS OF SOIL WATER RECHARGE AND DEPLETION

There is no certainty in sciences where one of the mathematical sciences cannot be applied, or which are not in relation with these mathematics.

Leonardo da Vinci

A series of two- and three-way analysis of variance (AOV) tests were designed to test the effects of grazing intensity, soil type, and three topographic variables on soil water recharge and soil water depletion. Soil water content data used in these analyses were collected during the period August, 1970, to August, 1971. By analyzing precipitation data for this same period, it was possible to conveniently define recharge and depletion periods. The recharge period, September 1, 1970, to May 8, 1971, was further subdivided into two periods, September 1 to March 25, where recharge was mostly due to snowmelt, and March 25 to May 1, where recharge was due to rain only. The depletion period was defined as that period between May 8 and August 20, 1971. Summaries of the soil water content data appear in Appendix B.

The precipitation data used for this study were collected with Belfort recording precipitation gages located at microwatersheds 2, 5, and 7 (See Figure 4.1), to correspond with the heavy-, medium-, and light-grazed sampling transects. In some cases, sampling points in the soil water transects were as far as 500 m from a precipitation gage. This poses a potential problem if one is attempting to compute an accurate water balance for the transects. Large variations in the areal precipitation distribution on the Pawnee Site have been observed for

convective rain events. However, it is doubtful that extreme spatial variability occurs during the winter and spring, when frontal storms predominate. As a check on the spatial distribution of rainfall along each of the sampling transects, standard "forester-type" gages were located on the transects at intervals not exceeding 300 m. These gages were read after each event of 0.1 cm size or larger during the period when convective events were common. These data were later compared with the recording gage data and appropriate adjustments made.

The Water Balance Equation

Slatyer (1967) expresses the water balance equation as

$$P - O - U - E + \Delta W = 0 \quad , \quad [5.1]$$

where P is precipitation, O is outflow or runoff, U is downward drainage through the lower soil boundary, E is the sum of evaporation, transpiration, and snow sublimation, and ΔW is the change in soil water storage (initial minus final). Following the advice of McKay (1970), a term for snow redistribution is added, and, with appropriate modifications in notation, equation [5.1] becomes

$$P - \Delta S = O + U + E - \Delta \theta \quad , \quad [5.2]$$

where ΔS is the change in snow storage (initial minus final), and $\Delta \theta$ is the change in soil water storage (initial minus final) in a 150 cm profile. In this equation P refers to gage catch and is assumed to be a reasonably good estimate of rainfall or snowfall incident upon the

ground or vegetation surface. A positive ΔS signifies snow lost from the site due to redistribution by wind, whereas a negative ΔS represents a net amount of snow blown onto the site from upwind sources.

Two terms in equation [5.2] are considered negligible for the period of this study. Only two runoff events occurred between September 2, 1970, and August, 1971. These events resulted from the storms of September, 1970, and May 22, 1971, and each amounted to less than 1 mm of runoff. Although soil water depletion occurred below the 150 cm level this year, as shown in Figure 5.1, it is highly unlikely that percolation of water occurs beyond this depth. Careful analysis of Figures 5.2a and 5.2b suggests that spring rains recharged the soil to a depth of approximately 75 cm; subsequent redistribution of soil water increased the soil water content at depths below 90 cm. A slight increase was noted at the 150 cm depth on June 4, nearly a month following the last significant precipitation event. Striffler (1972) feels that it is probably very rare to find the 150 cm depth with an average water content approaching field capacity. The average volumetric water content for the 150 cm depth deviated very little from a value of 0.177 over the recharge period. For most soils on the study area this corresponds to a matric potential of less than -1.0 bar. Thus, it is unlikely that any saturated flow or any significant unsaturated flow occurs at this depth.

The winter water balance. If the runoff and subsurface drainage terms are deleted and the resulting equation rearranged, we arrive at the expression,

$$P + \Delta\theta = \Delta S + E \quad , \quad [5.3]$$

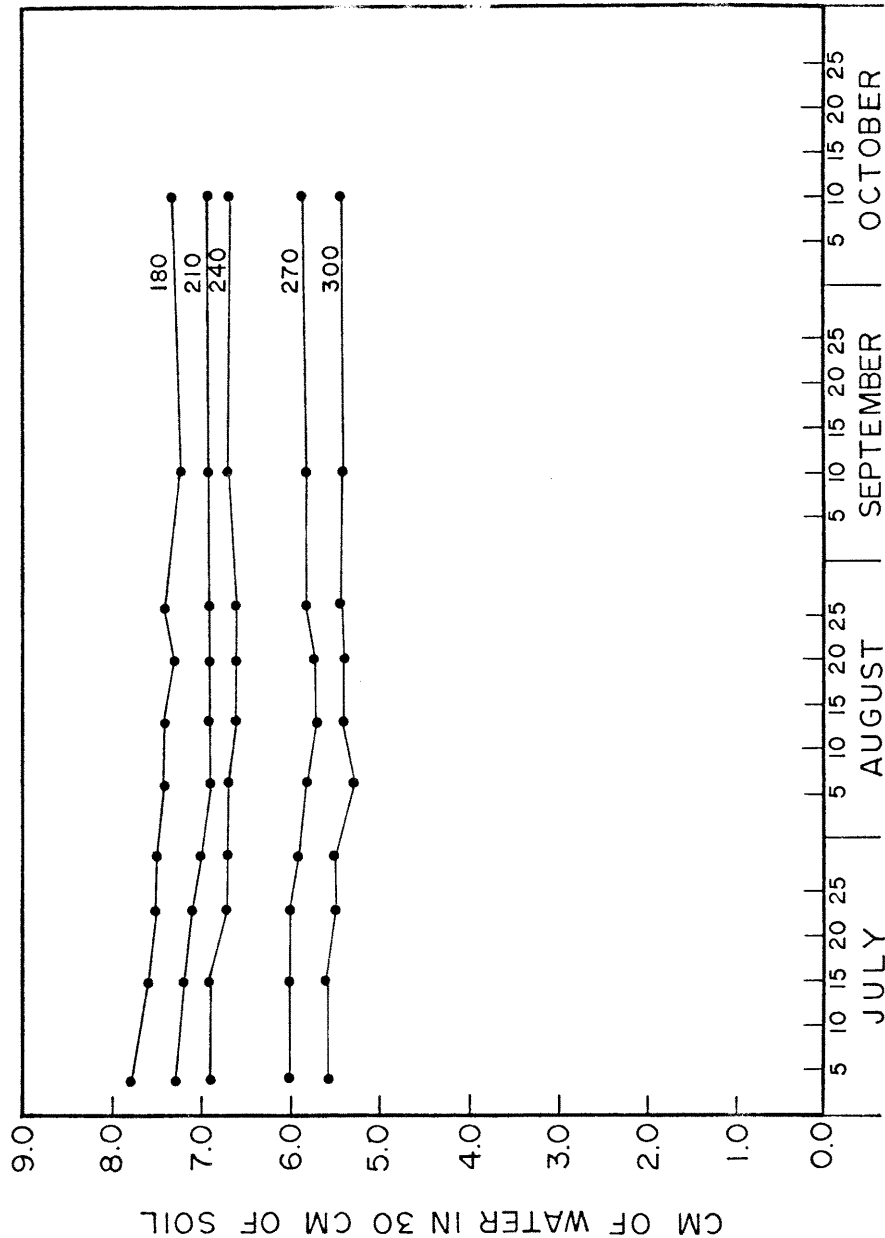

Figure 5.1. The growing season trend in soil water storage at depths below 150 cm. Values represent the mean of 5 samples. Tubes sampled include #9 and #13 of Transect No. 1 (heavily grazed); #7 of Transect No. 2 (lightly grazed); and #6 and #16 of Transect #3 (moderately grazed).

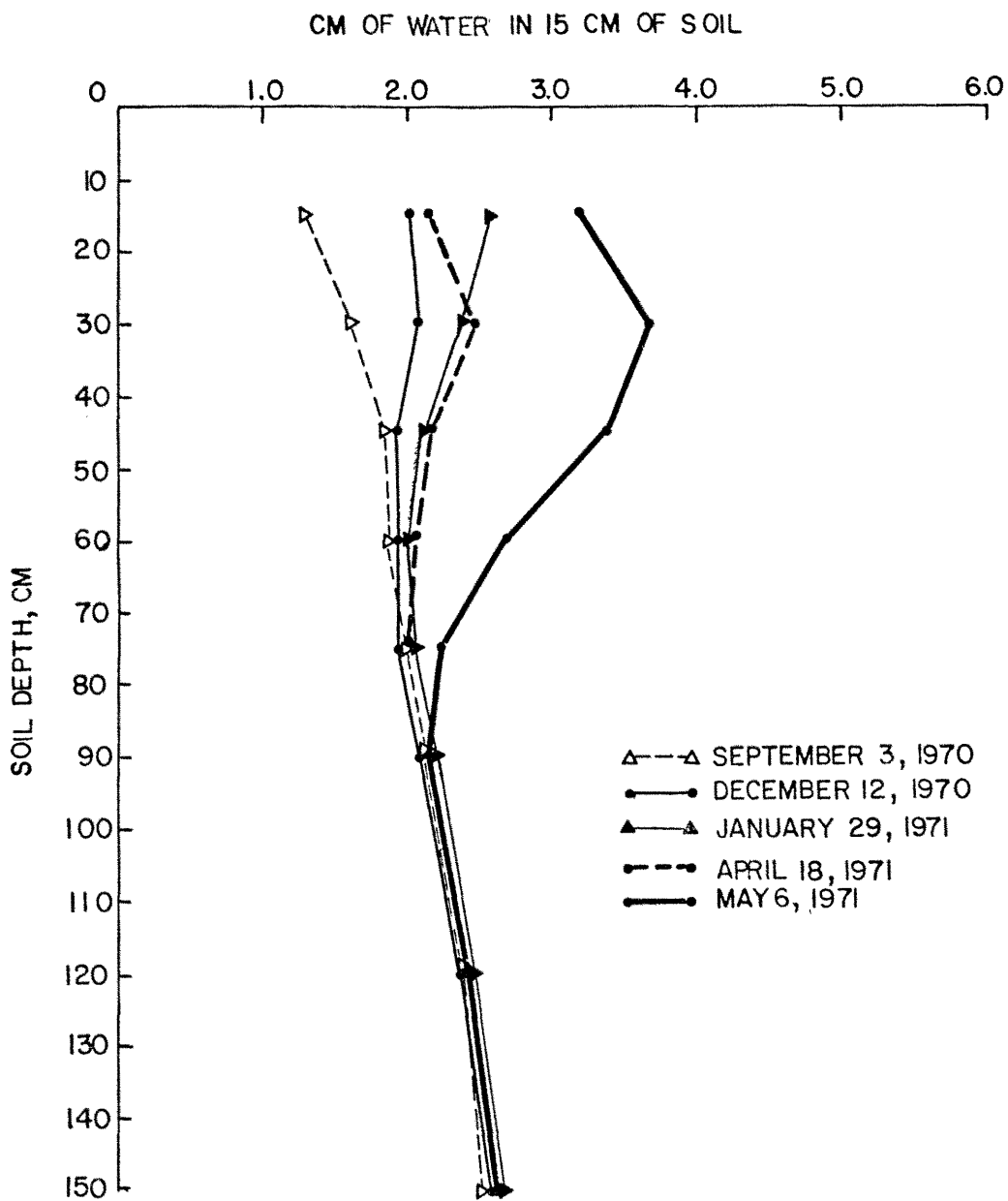

Figure 5.2a. Soil water content as a function of both time and depth for the 1970-71 recharge period averaged, over all soil types and grazing treatments.

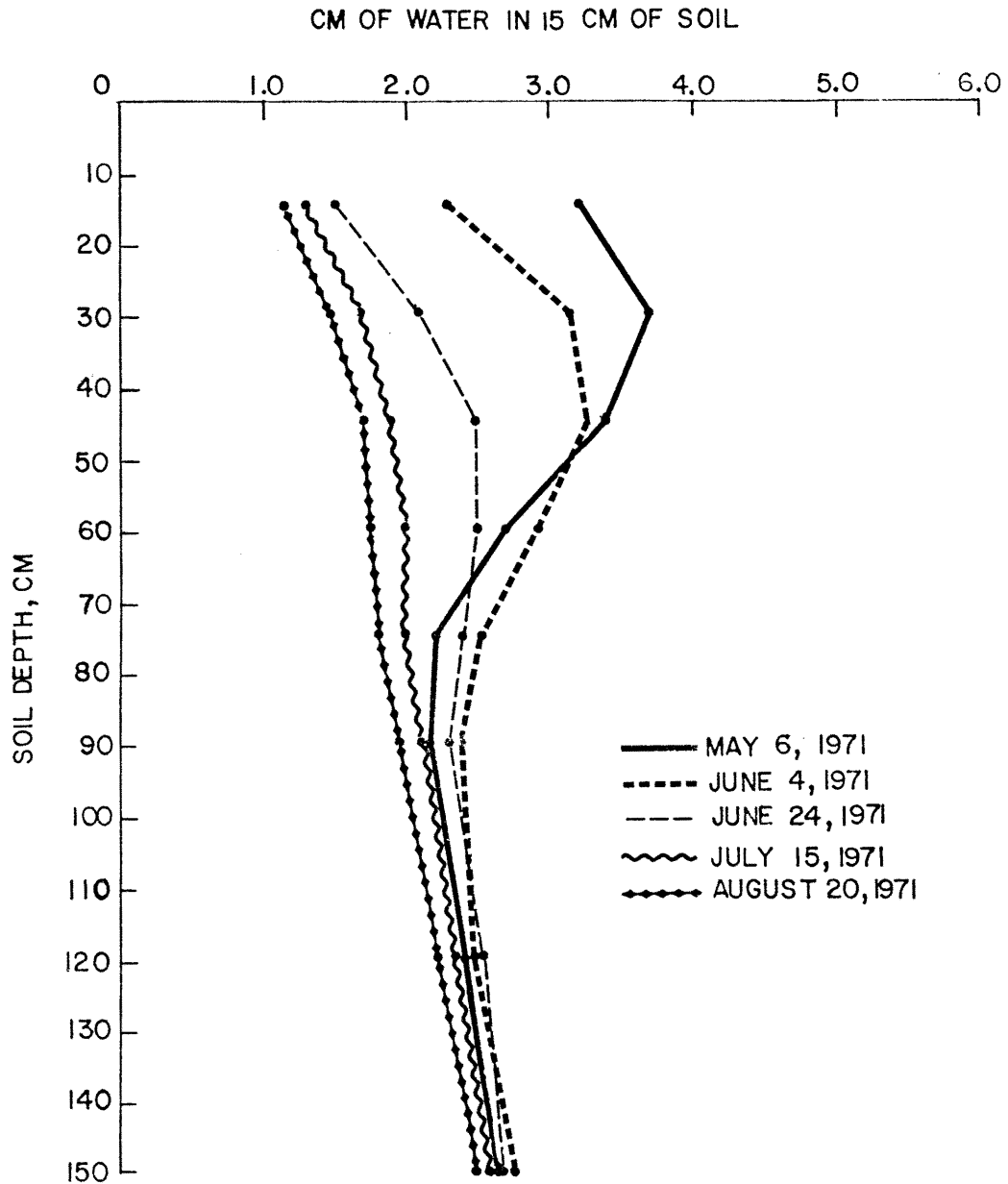

Figure 5.2b. Soil water content as a function of both time and depth for the 1971 depletion period, averaged over all soil types and grazing treatments.

where the terms on the lefthand side were measured in this study and those on the right were not measured. Equation [5.3] represents the winter water balance for the study area, covering the period where recharge was due mostly to snow. For this period, average total precipitation amounted to 10.5 cm and the average $\Delta\theta$ was -4.1 cm. By using equation [5.3], the term $(\Delta S + E)$ is computed to be 6.4 cm. This means that approximately 60% of the total available precipitation is lost to a combination of evaporation and wind redistribution of snow. It is difficult to effectively assess the relative contributions of ΔS and E to the total loss of 6.4 cm. Since most of the vegetation on the site is dormant under winter conditions, transpiration is negligible. Given the low air temperatures and reduced solar radiation during this period, evaporation from soil and snow surfaces probably does not exceed an average of 0.15 mm per day or approximately 3.0 cm for the entire winter season. Thus, over 50% of the 6.4 cm loss is likely due to wind transporting snow off the site.

Visual observations of snow accumulation patterns on the shortgrass prairie suggest that vegetation height, position-on-slope, and slope exposure to prevailing winds all play an important role in snow retention. These variables were all tested using analysis-of-variance techniques. To account for spatial variability in snowfall, the response variable was $(P + \Delta\theta)$, which could be calculated for each of the 60 sampling tube sites in the study. From the identity represented in equation [5.3], it follows that the term $(\Delta S + E)$ is also the response variable, mathematically equivalent to $(P + \Delta\theta)$.

Since subclass cell frequencies would be uneven, and in some cases zero, throughout the analysis-of-variance testing, a very flexible AOV test capable of handling these data was needed. STAT31V, available from the CSU Statistical Laboratory, was used for all the two-way and three-way AOV tests made in the study.

Initially, a three-way analysis was made of the response variable ($\Delta S + E$), testing three levels of grazing intensity, five levels of slope position, and two levels of exposure. The levels of grazing intensity were heavy, moderate, and light. The five levels of slope position were defined as ridgetop, upper 1/3, middle 1/3, lower 1/3 and bottom. Exposure was divided into leeward and windward sites, assuming a prevailing wind of north to northwest. Quantitatively, the windward sites were defined as those having an azimuth between 225° (SW) and 45° (NE), whereas the leeward sites had azimuths between 45° (NE) and 225° (SW). The results of this test are presented in Table 5.1. The effect of exposure was significant at the 0.95 level, with windward sites and leeward sites losing averages of 7.2 and 5.8 cm of water, respectively, to evaporation and wind transport of snow. The effects of slope position and grazing intensity were not statistically significant in this analysis. Because the three-way test meant that many subclass cells were empty, three two-way tests, representing the three possible combinations of two factors each, were attempted. The results of these tests are shown in Table 5.2a-c. For the analysis of slope position X exposure, the exposure effect was again significant at the 0.95 level. The same was true for the exposure X grazing test. Exposure was obviously the dominating effect in the above tests; in its absence, slope position and grazing intensity fared much better. In the slope

Table 5.1. AOV table for results of the three-way model, slope position x grazing intensity x exposure. The response variable is $(P + \Delta\theta)$ or $(\Delta S + E)$.

Analysis of Variance Table				
<u>Source</u>	<u>df</u>	<u>SS</u>	<u>MS</u>	<u>F-ratio</u>
Mean	1	2437.16		
Slope Position	4	25.56	6.39	1.44
Grazing	2	15.74	7.87	1.77
Exposure	1	24.12	24.12	*5.43
Interactions	18	105.84	5.88	1.33
Within	34	150.87	4.44	
Total	60	2763.08		

*Significant at 0.95 level

Table 5.2a-c. AOV tables representing the models, (a) slope position X exposure, (b) exposure X grazing intensity, and (c) slope position X grazing intensity. The response variable is $(P + \Delta\theta)$ or $(\Delta S + E)$.

ANALYSIS OF VARIANCE TABLES

Table 5.2a

<u>Source</u>	<u>df</u>	<u>SS</u>	<u>MS</u>	<u>F-ratio</u>
Mean	1	2437.16		
Slope Position	4	25.79	6.45	1.27
Exposure	1	29.64	29.64	*5.86
Interaction	4	19.36	4.84	0.96
Within	50	253.09	5.06	
Total	60	2763.08		

*Significant at 0.95 level

Table 5.2b

<u>Source</u>	<u>df</u>	<u>SS</u>	<u>MS</u>	<u>F-ratio</u>
Mean	1	2437.16		
Exposure	4	49.10	16.37	*3.43
Grazing	1	27.83	13.91	2.92
Interaction	4	24.41	4.88	1.62
Within	50	233.84	4.77	
Total	60	2763.08		

*Significant at 0.95 level

Table 5.2c

<u>Source</u>	<u>df</u>	<u>SS</u>	<u>MS</u>	<u>F-ratio</u>
Mean	1	2437.16		
Slope Position	4	49.56	12.39	*2.87
Grazing	2	9.37	4.68	1.09
Interaction	8	86.72	10.84	*2.51
Within	45	194.11		
Total	60	2763.08		

*Significant at 0.95 level

position X grazing test, both the slope position and slope position X grazing interaction effects were significant at the 0.95 level. Figure 5.3 shows these two effects quite clearly. If it is assumed that topography and grazing intensity have very little influence on winter evaporation, the effects evident in Figure 5.3 are due largely to the influence of slope position and grazing intensity on snow retention. Although the mean values of $(P + \Delta\theta)$ for the three levels of grazing intensity are not statistically significant, nevertheless, there is a trend of increasing $(P + \Delta\theta)$ with increasing grazing pressure. The interpretation of these results is given in Chapter VI.

The growing season water balance. Unfortunately, the period of soil water recharge due to rainfall coincides partly with the beginning of the growing season. This means that some vegetation was growing and actively transpiring during the rain recharge period. The following water balance equation may be written for the spring and summer hydrologic regimes:

$$P = O + E - \Delta\theta \quad [5.4]$$

The runoff term, O , is included here since in some years runoff-producing storm events may be frequent enough to give a significantly large cumulative runoff component. Moreover, it is possible that, for high intensity storms, rainfall rates might exceed infiltration rates on some sites. A combination of upper slope positions and heavily-grazed conditions might interact to produce a local runoff event not experienced by the microwatersheds. Consequently, an AOV test was designed to check for this effect. For the rain recharge period, average values

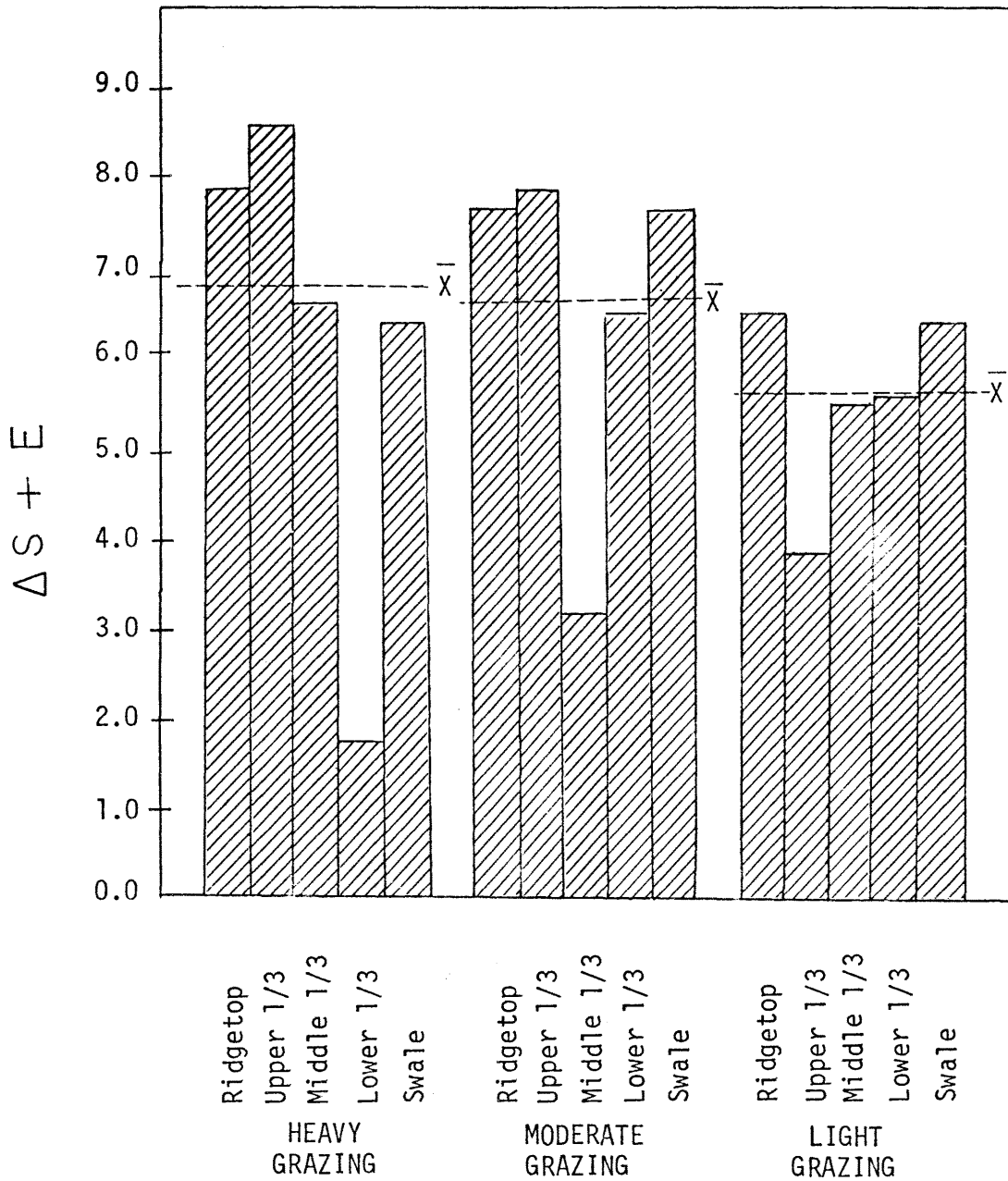

Figure 5.3. The interactive effects of slope position and grazing intensity on $(P + \Delta\theta)$ or $(\Delta S + E)$.

of P and $\Delta\theta$ were 7.8 and -4.2 cm of water, respectively, resulting in a mean value of 3.6 for $(P + \Delta\theta)$ and $(O + E)$. Accurate partitioning of the $(O + E)$ term into the separate components, runoff and evapotranspiration, is very difficult. Using the $(P + \Delta\theta)$ again as the response variable, a test for the main and interaction effects was performed for the combination, slope position \times grazing intensity. The analysis showed no significant effects, and no clear pattern in the subclass means was evident. However, the mean value for the upper slope position sites on the heavily-grazed transect was 5.0 as opposed to 3.4, the mean for that grazing treatment, and 4.1, the mean for that slope position. This result is worthy of discussion, since the slope position \times grazing intensity interaction effect would be expected to have the strongest influence on runoff at the heavily-grazed upper slope positions. However, as before, we again have to make the assumption that grazing intensity and slope position had no effect on evapotranspiration during this particular period of study. This same test was made for total recharge (snow plus rain). Again, $(P + \Delta\theta)$ was the response variable, with the term $(\Delta S + O + E)$ as the identity. The results were similar to those obtained from the slope position \times grazing intensity test for the snowmelt recharge case. Slope position was a significant effect at the 0.95 level. However, the interaction effect in this case was significant at the 0.99 level. The pattern in the subclass means was nearly identical to that for the snowmelt recharge analysis, suggesting that recharge due to snowmelt plays an important role in the distribution of total soil water recharge. The seasonal distribution of total soil water recharge for the three grazing intensities is shown in Figure 5.4.

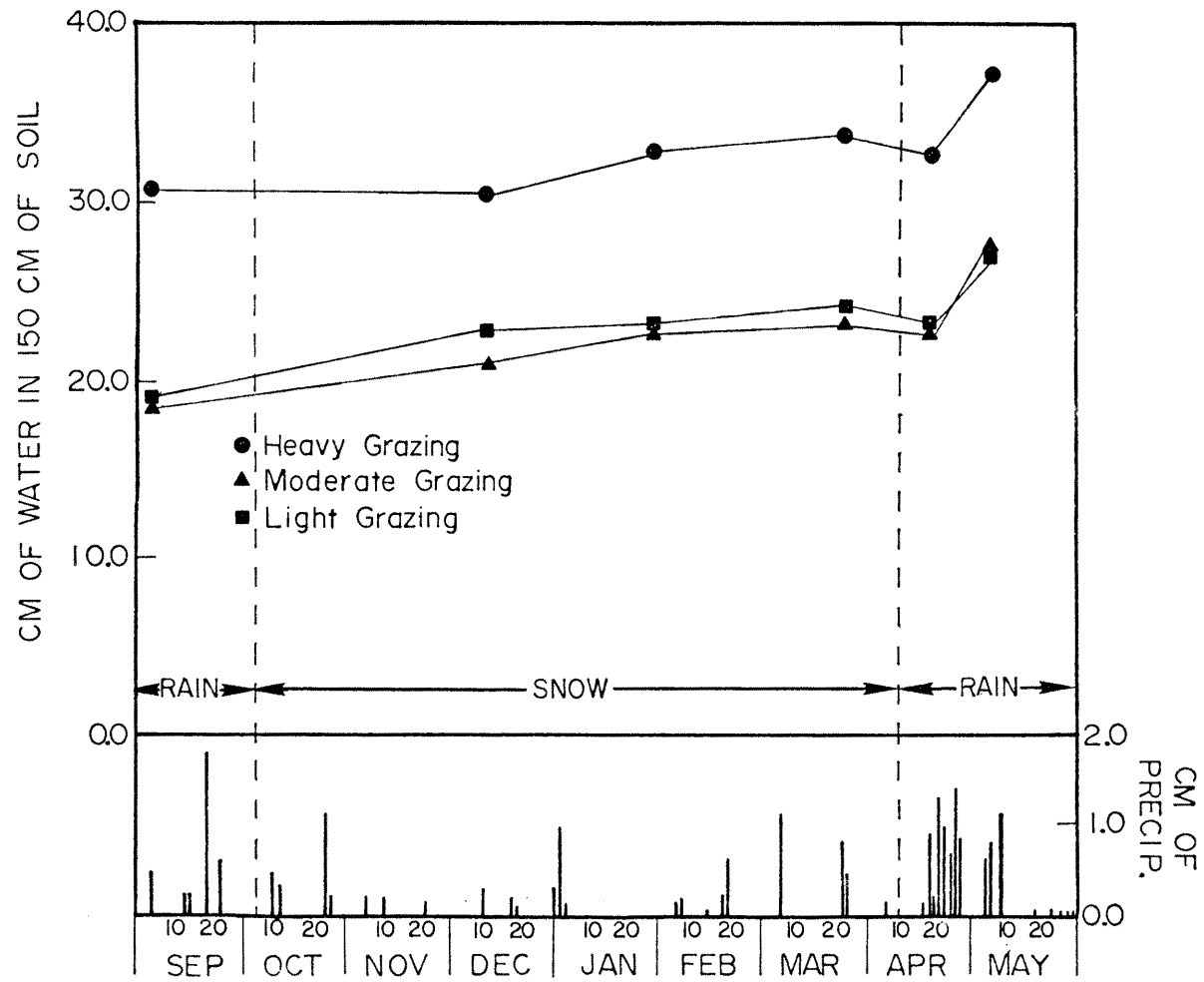

Figure 5.4. Seasonal distribution of soil water storage by grazing treatment.

For the period August, 1970, to August, 1971, an analysis of soil water contents of the 150 cm profile showed the mean total soil water depletion exceeded mean total soil water recharge by 1.1 cm of water. This difference is due almost exclusively to the influence of the heavily-grazed transect, where depletion exceeded recharge by 2.8 cm of water. Differences between depletion and recharge were negligible (0.1 and 0.0 cm) for the moderate-and light-grazed transects. The seasonal distribution of soil water depletion for the three grazing treatments appears in Figure 5.5. Analysis-of-variance models were designed to test the grazing treatment effect on soil water depletion, as well as the effects due to soil type, slope aspect, and position-on-slope. All six major soil types reported on earlier were used in this analysis. Aspect was subdivided into four levels, with Level 1 representing the azimuth segments 0° to 45° and 315° to 360° , Level 2 representing the azimuths between 45° and 125° , Level 3 representing 240° to 315° , and Level 4 representing 125° to 240° . Theoretically, the solar radiation available for evapotranspiration should increase from aspect Level 1 to Level 4. Visual analysis of Figure 5.5 suggests that the depletion period can be separated into two depletion periods on the basis of mean daily depletion. These periods were selected as May 8 to June 24, 1971 (early depletion, $\Delta\theta_1$), and June 24 to August 20, 1971 (late depletion, $\Delta\theta_2$). The same three AOV tests were made on both these depletion periods, as well as on the total seasonal depletion ($\Delta\theta_T$). The first AOV tested soil type X grazing, using $(P + \Delta\theta_1)$ as the response variable. From equation [5.4] it can be shown that $(P + \Delta\theta_1)$ is equivalent to evapotranspiration, E , for the same period. Only the grazing treatment effect was statistically significant (0.99 level) in

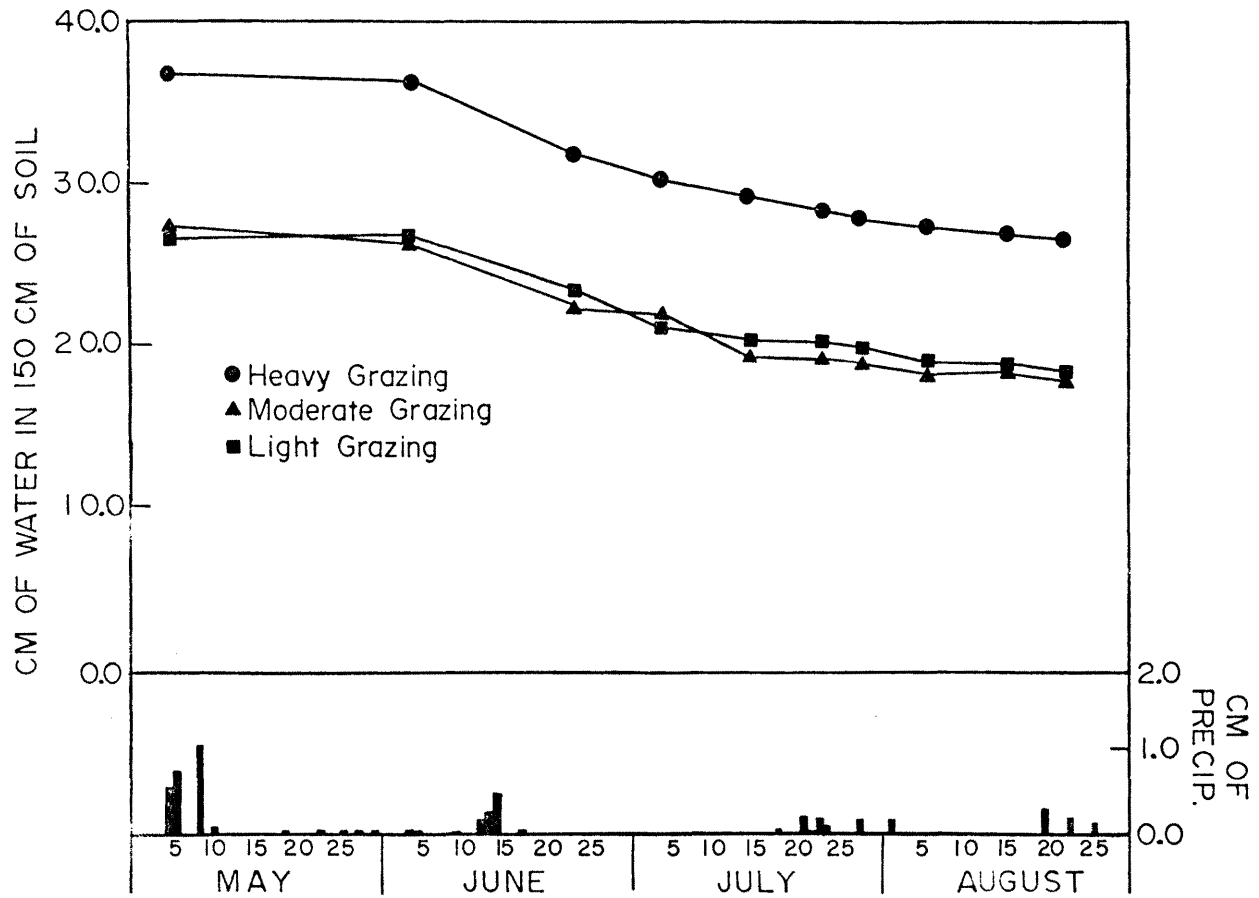

Figure 5.5. Seasonal distribution of soil water storage by grazing treatment.

this analysis. The medium-grazed treatment level appeared to have the highest evapotranspiration amount for the period (9.6 cm of water), followed by the heavy (9.1 cm) and light (7.6 cm) grazing levels. These AOV results are presented in Table 5.3, and interpretations discussed in Chapter VI. The second analysis tested the main and interaction effects of the aspect X grazing model. Again, grazing was highly significant at the 0.99 level (Table 5.3). An analysis of the slope position X grazing also showed grazing intensity to have a highly significant effect on early depletion (Table 5.3). In addition, slope position was significant at the 0.95 level, with the following slope positions ranked according to mean ($P + \Delta\theta_1$):

Ridgetop (9.3) > Bottom (9.2) > Lower 1/3 (9.1) > Middle 1/3 (8.9)
> Upper 1/3 (7.8)

Table 5.3a-c. AOV tables representing the models, (a) soil type X grazing intensity, (b) aspect X grazing intensity, and (c) slope position X grazing intensity. The response variable is $(P + \Delta\theta_1)$ or early evapotranspiration

ANALYSIS OF VARIANCE TABLES

Table 5.3a

<u>Source</u>	<u>df</u>	<u>SS</u>	<u>MS</u>	<u>F-ratio</u>
Mean	1	4678.13		
Soil type	5	13.13	2.63	0.87
Grazing	2	31.18	15.59	**5.22
Interactions	4	6.26	1.56	0.52
Within	48	143.42	2.99	
Total	60	4882.3		

**Significant at 0.99 level

Table 5.3b

<u>Source</u>	<u>df</u>	<u>SS</u>	<u>MS</u>	<u>F-ratio</u>
Mean	1	4678.13		
Aspect	3	18.12	6.04	2.22
Grazing	2	53.74	26.87	**9.89
Interactions	5	11.57	2.31	0.85
Within	49	133.12	2.72	
Total	60	4882.30		

**Significant at 0.99 level

Table 5.3c

<u>Source</u>	<u>df</u>	<u>SS</u>	<u>MS</u>	<u>F-ratio</u>
Mean	1	4678.13		
Slope position	4	26.52	6.63	*2.78
Grazing	2	42.72	21.36	**8.96
Interactions	8	36.24	4.53	1.90
Within	45	107.29	2.38	
Total	60	4882.30		

*Significant at 0.95 level
**Significant at 0.99 level

Somewhat different results were obtained using the same three AOV models, with $(P + \Delta\theta_2)$ as the response variable. Only the slope position X grazing model had statistically significant effects. Slope position was highly significant at the 0.99 level and grazing intensity was significant at the 0.95 level (Table 5.4). In terms of mean $(P + \Delta\theta_2)$, grazing intensity was ranked as

Heavy (6.7) > Light (6.6) > Moderate (5.7) ,

and slope position was ranked as

Lower 1/3 (7.1) > Middle 1/3 (6.7) > Upper 1/3 (6.7) >
Bottom (5.7) > Ridgetop (5.3) .

When $(P + \Delta\theta_T)$, the total seasonal evapotranspiration, was made the response variable, the aspect X grazing analysis resulted in grazing pressure having a significant (0.95 level) effect. No effects were evident in the soils X grazing model; the lack of a soil type effect is shown graphically in Figures 5.6, 5.7, and 5.8. The results of the slope position X grazing intensity AOV were somewhat more conclusive. Both main effects and the interaction effect were highly significant at the 0.99 level. The results of this test are presented in Table 5.5 and Figure 5.9, and discussed in Chapter VI.

Results of Multiple-Variable Regression Analyses

Regression models of the three recharge variables and three depletion variables were proposed so that the relative contribution of soil,

Table 5.4. AOV table representing the model, slope position X grazing intensity. The response variable is $(P + \Delta\theta_2)$ or late evapotranspiration.

ANALYSIS OF VARIANCE TABLE				
<u>Source</u>	<u>df</u>	<u>SS</u>	<u>MS</u>	<u>F-ratio</u>
Mean	1	2413.00		
Slope position	4	27.17	6.79	**4.19
Grazing	2	12.07	6.04	*3.72
Interactions	8	7.73	0.97	0.50
Within	45	72.99	1.62	
Total	60	2531.11		

*Significant at 0.95 level
**Significant at 0.99 level

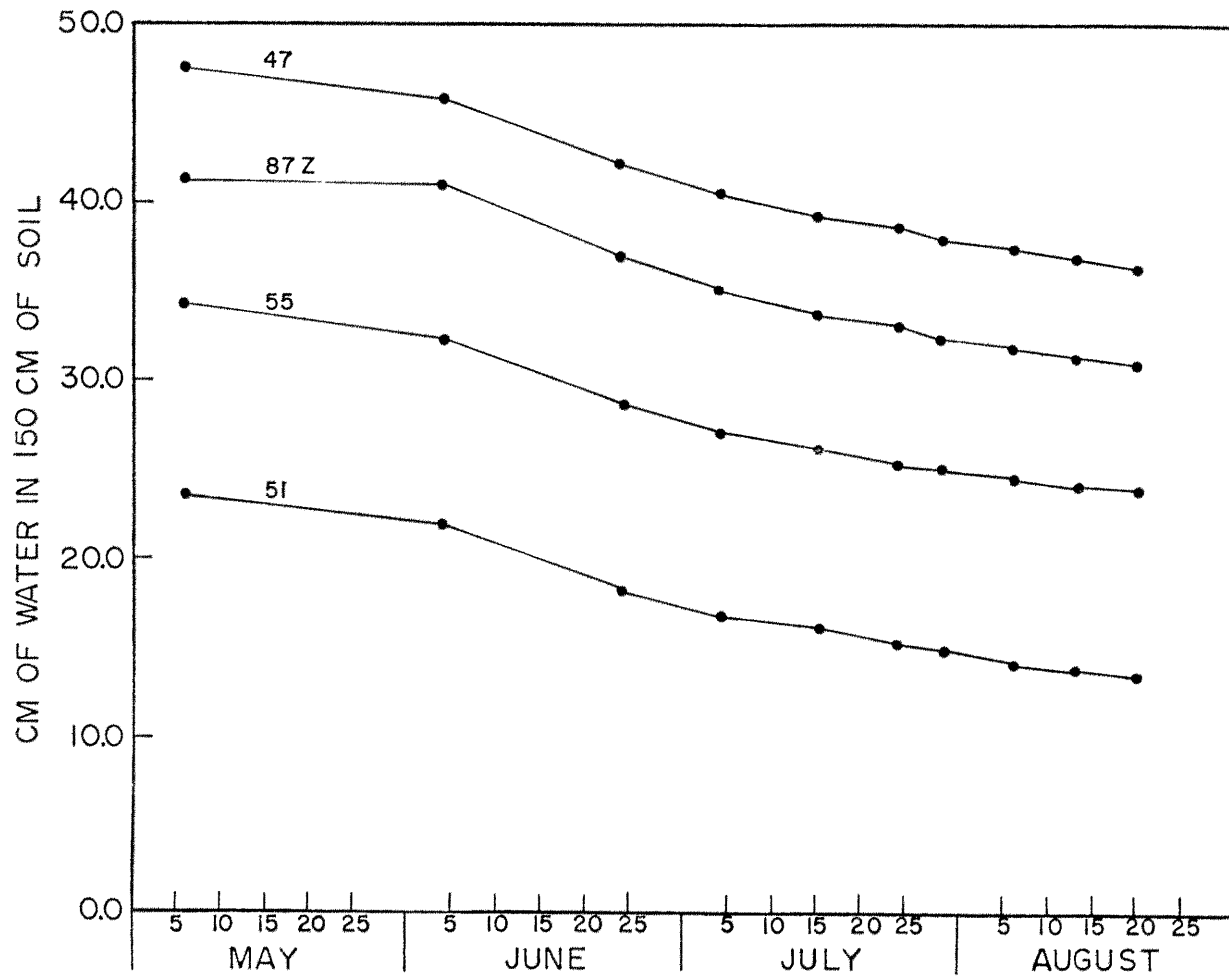

Figure 5.6. Seasonal distribution of soil water depletion by soil type for the heavily-grazed transect.

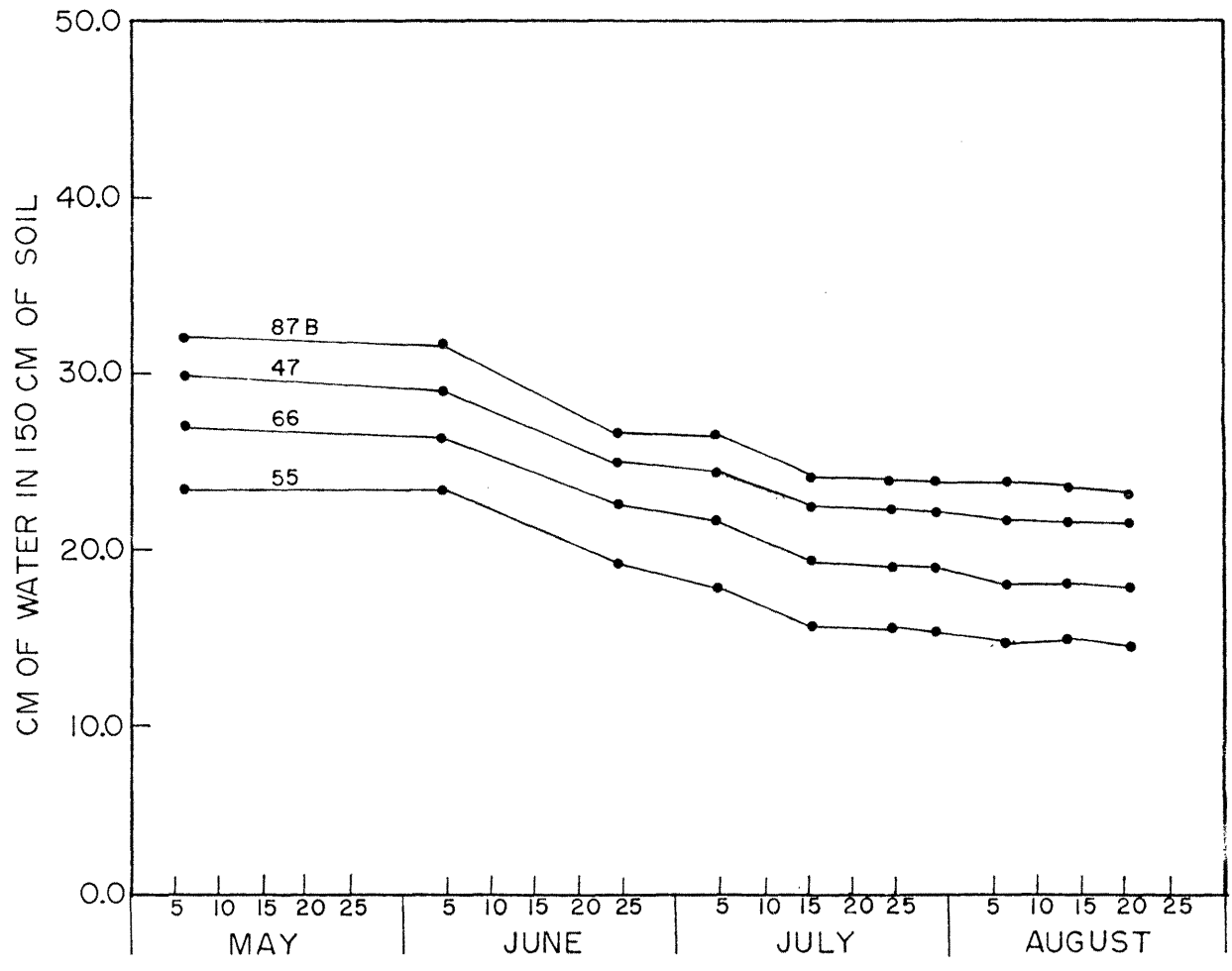

Figure 5.7. Seasonal distribution of soil water depletion by soil type for the moderately-grazed transect.

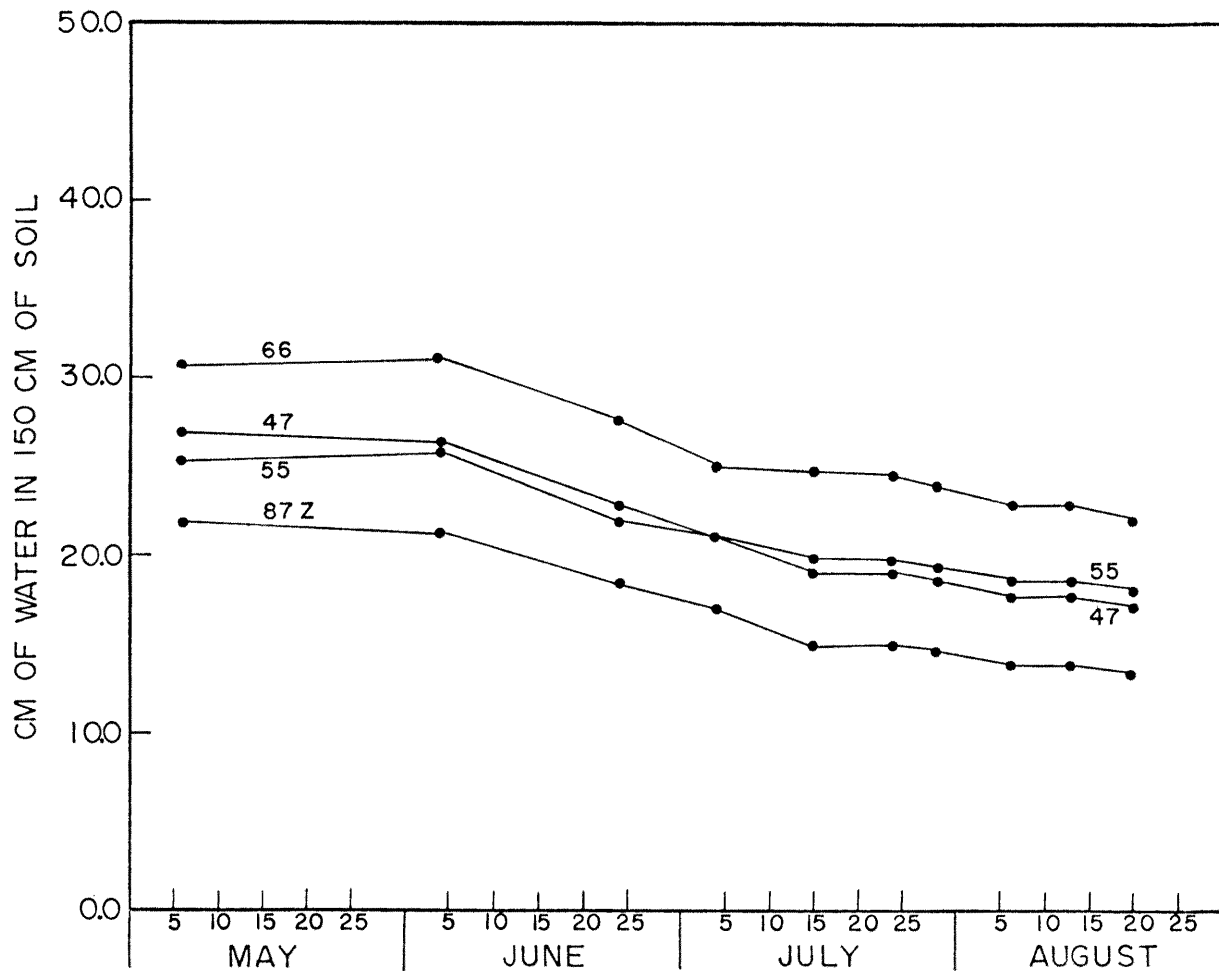

Figure 5.8. Seasonal distribution of soil water depletion by soil type for the lightly-grazed transect.

Table 5.5. AOV table representing the model, slope position X grazing intensity. The response variable is $(P + \Delta\theta_T)$ or total evapotranspiration.

ANALYSIS OF VARIANCE TABLE				
<u>Source</u>	<u>df</u>	<u>SS</u>	<u>MS</u>	<u>F-ratio</u>
Mean	1	13686.64		
Slope position	4	52.00	13.00	**7.16
Grazing	2	30.66	15.33	**8.44
Interactions	8	53.30	6.66	**3.67
Within	45	13871.08	1.82	

**Significant at the 0.99 level

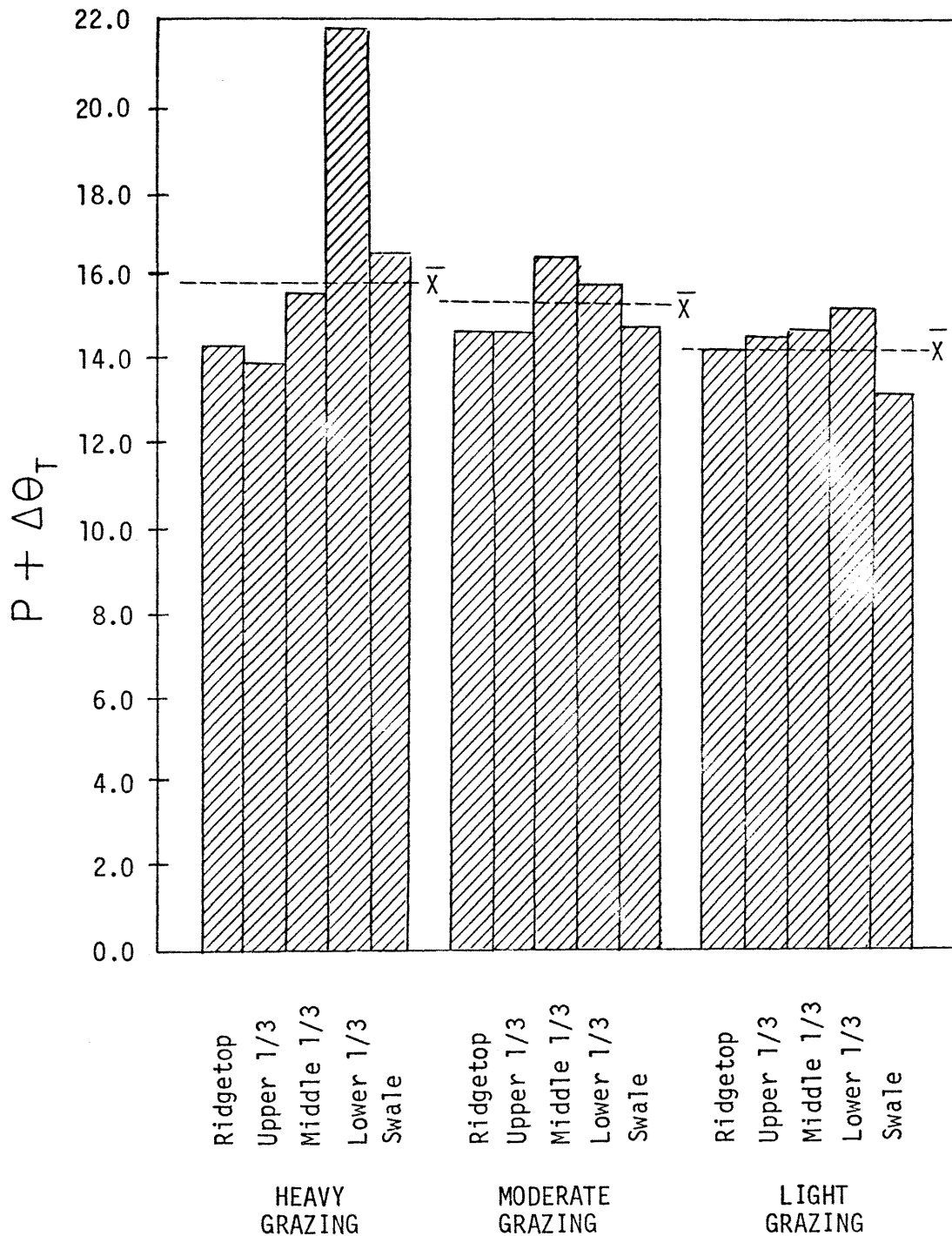

Figure 5.9. The interactive effects of slope position and grazing intensity on $(P + \Delta\theta_T)$ or total evapotranspiration for the growing season.

grazing, and topographic effects could be assessed in terms of their ability to explain the variability in soil water recharge and soil water depletion in the Lynn Lake watershed. Such regression models are logical steps in the approach to modeling the hydrologic balance of a drainage basin. Table 5.6 lists all the independent variables used in the six regression analyses performed on the sampling transect data. Although the regression analyses were not successful in terms of explaining the amount of variance associated with each dependent variable, several interactions between topographic and vegetational factors appear to be important. This supports the underlying hypothesis of this paper that soil water recharge and soil water depletion on the prairie are highly complex phenomena and dependent upon a multitude of interdependent variables. With this in mind, a "shotgun" approach was deemed necessary in the following regression analyses. Nearly all the 45 independent variables identified in the study, except those which were known to have strong interdependence with the dependent variable, were included in each analysis. In each sub-problem, deletions of variables were made where the specific independent variable had no physical relationship with the dependent variable. Table 5.7 is a matrix of simple r coefficients for all possible combinations of variables.

In each analysis, large numbers of independent variables, explaining only 1 to 2% of the variance, were generated. Normally, only those variables explaining 3% or more of the variance were included in the regression summaries. The regression AOV, regression coefficients, and standard error of estimate are given in Appendix C for each of the six analyses. All six regression tests were significant at the 0.99 level.

Table 5.6 The variables used in the six regression analyses.

<u>Variable No.</u>	<u>Code Name</u>	<u>Description</u>
X (1)	RG(S)	Soil water recharge due to snow (cm)
X (2)	RG(R)	Soil water recharge due to rain (cm)
X (3)	RG(T)	Total soil water recharge (cm)
X (4)	DPLTN	** VOIDED VARIABLE **
X (5)	GRAZ	Grazing intensity (lbs. acre ⁻¹)
X (6)	VEGHT	Mean vegetation height (cm)
X (7)	ASAND	% sand in A horizon
X (8)	BSAND	% sand in B horizon
X (9)	CSAND	% sand in C horizon
X (10)	ASPCT	Aspect ranking
X (11)	SLØPE	Slope gradient (%)
X (12)	PØS (R)	** VOIDED VARIABLE **
X (13)	EXPØS	Wind exposure ranking
X (14)	SFCBD	Surface soil bulk density (gm cm ⁻³)
X (15)	P-SR	** VOIDED VARIABLE **
X (16)	P-RR	** VOIDED VARIABLE **
X (17)	P-TR	** VOIDED VARIABLE **
X (18)	P+D	Precipitation + total depletion (cm)
X (19)	P+D1	Precipitation + early depletion (cm)
X (20)	P+D2	Precipitation + late depletion (cm)

Table 5.6 (continued)

<u>Variable No.</u>	<u>Code Name</u>	<u>Description</u>
X (21)	H2ØA	Available water A horizon (%)
X (22)	H2ØB	Available water B horizon (%)
X (23)	PØS (S)	** VØIDED VARIABLE **
X (24)	P-SRJ	** VØIDED VARIABLE **
X (25)	SR/TR	Snow recharge ÷ total recharge
X (26)	PØS (S)	Slope position (S) ranking
X (27)	PØS (TD)	Slope position (TD) ranking
X (28)	PØS (D1)	Slope position (D1) ranking
X (29)	PØS (D2)	Slope position (D2) ranking
X (30)	PØS (TR)	Slope position (TR) ranking
X (31)	PØS (RR)	Slope position (RR) ranking
X (32)	-	X(11)* X (26)
X (33)	-	X(6) * X (26)
X (34)	-	X(6) * X (26)* X (11)
X (35)	-	X(6) * X (26)* X (13)
X (36)	-	X(6) * X (26)* X (11)* X (13)
X (37)	-	X(27) / X (5)
X (38)	-	H2Ø A + H2Ø B
X (39)	-	X(28) / X (5)
X (40)	-	X(29) / X (5)
X (41)	-	X(11)* X (30)
X (42)	-	X(11)* X (30)* X (5)

Table 5.6 (continued)

<u>Variable No.</u>	<u>Code Name</u>	<u>Description</u>
X (43)	-	X(31) / X (11)
X (44)	-	X(31) / X (11)* X (5)
X (45)	-	X(10)* X (11)

Table 5.7. Matrix of simple correlation coefficients for all possible combinations of variables.

VARIABLE NUMBER	1	2	3	4	5	6	7	8	9	10
1	1.000	-.158	.866	.368	.302	.296	.101	-.006	.186	.182
2		1.000	.357	.403	-.236	-.206	.147	.211	.299	-.282
3			1.000	.552	.166	.176	.170	.101	.327	.029
4				1.000	-.471	-.466	-.029	.009	-.046	-.044
5					1.000	.980	.426	.179	.333	.147
6						1.000	.439	.187	.330	.188
7							1.000	.467	.444	-.029
8								1.000	.539	-.181
9									1.000	-.155
10										1.000
VARIABLE NUMBER	11	12	13	14	15	16	17	18	19	20
1	.282	.078	.309	.033	-.978	.151	-.842	.450	.333	.118
2	-.141	-.112	-.145	-.024	.150	-.992	-.379	.406	.550	-.208
3	.196	.017	.219	.019	-.849	-.359	-.989	.632	.594	.006
4	.083	.150	-.229	.323	-.442	-.386	-.619	.964	.619	.401
5	.272	.013	.561	-.321	-.173	.219	-.048	-.303	-.216	-.118
6	.290	-.015	.555	-.285	-.136	.164	-.042	-.261	-.132	-.170
7	.173	.027	.270	-.045	-.027	-.163	-.111	.075	.063	.004
8	-.088	.334	.175	.140	.040	-.216	-.075	.057	.281	-.301
9	-.190	.155	.165	.060	-.142	-.299	-.290	.020	.229	-.283
10	.284	.039	.451	-.000	-.129	.247	.008	.026	-.010	.049
11	1.000	-.279	.205	-.057	-.232	.120	-.156	.165	-.037	.251
12		1.000	.040	.110	-.101	.127	-.028	.134	.119	.007
13			1.000	-.287	-.235	.132	-.152	-.127	.010	-.183
14				1.000	-.053	.009	-.045	.309	.099	.266
15					1.000	-.166	.856	-.470	-.303	-.181
16						1.000	.368	-.417	-.586	.239
17							1.000	-.661	-.593	-.045
18								1.000	.694	.348
19									1.000	-.433
20										1.000

Table 5.7 (continued)

VARIABLE NUMBER	21	22	23	24	25	26	27	28	29	30
1	-.198	.242	.094	-.207	.863	.220	.218	-.094	.247	.208
2	.118	-.092	-.217	-.016	-.521	-.074	.041	.217	-.116	.120
3	-.128	.182	-.021	-.204	.553	.171	.227	.021	.175	.257
4	.086	.105	.048	-.641	.152	.315	.326	-.048	.283	.297
5	-.330	.100	-.099	.497	.395	-.155	.002	.099	.009	.022
6	-.309	.135	-.104	.450	.373	-.167	.003	.104	.012	.038
7	-.412	.099	.184	.191	.012	.217	.225	-.184	.351	.242
8	.093	-.202	-.177	.156	-.094	.161	.255	.177	.060	.141
9	-.141	-.103	.004	.267	.011	.056	.091	-.004	.092	.034
10	-.141	.194	.092	-.153	.239	.000	.002	-.092	.099	-.016
11	-.321	.154	.530	.009	.274	.218	.112	-.530	.552	.245
12	.256	.022	-.214	-.101	.172	.462	.534	.214	.199	.129
13	-.161	.154	-.049	.253	.368	-.110	-.056	.049	-.052	-.074
14	.098	.041	.081	-.236	-.019	-.014	.047	-.081	.158	.009
15	.170	-.202	-.116	.247	-.838	-.258	-.222	.116	-.248	-.196
16	-.121	.066	.219	.034	.514	.084	-.040	-.219	.112	-.125
17	.097	-.156	.005	.250	-.520	-.199	-.230	-.006	-.175	-.251
18	.041	.169	.025	-.620	.225	.288	.346	-.025	.306	.336
19	.160	.014	-.253	-.451	.064	.065	.190	.253	-.043	.177
20	-.150	.195	.365	-.197	.186	.277	.183	-.365	.439	.169
21	1.000	.003	-.210	-.040	-.165	.060	.057	.210	-.180	-.061
22		1.000	.106	-.080	.271	-.000	.016	-.106	.132	.010
23			1.000	.035	.107	.330	-.158	-1.000	.534	-.154
24				1.000	-.130	-.124	-.082	-.035	.009	-.036
25					1.000	.242	.214	-.107	.240	.154
26						1.000	.804	-.330	.762	.653
27							1.000	.158	.667	.903
28								1.000	-.584	.154
29									1.000	.642
30										1.000

Table 5.7 (continued)

VARIABLE NUMBER	31	32	33	34	35	36	37	38	39	40
1	.059	.315	.372	.374	.409	.447	.004	.004	-.201	-.041
2	.262	-.115	-.235	-.176	-.312	-.251	.248	.031	.345	.060
3	.189	.240	.233	.270	.229	.296	.129	.019	.004	-.008
4	.114	.236	-.009	.061	-.145	.005	.599	.133	.343	.518
5	.084	.108	.456	.416	.594	.503	-.675	-.188	-.582	-.694
6	.112	.113	.455	.428	.542	.520	-.677	-.149	-.579	-.694
7	.061	.268	.477	.414	.443	.431	-.141	-.251	-.407	-.072
8	.053	.078	.271	.161	.309	.201	.051	-.059	.031	-.105
9	-.043	-.120	.192	.020	.185	.040	-.088	-.174	-.198	-.143
10	-.075	.165	.164	.241	.383	.396	-.154	.017	-.175	-.067
11	.004	.756	.393	.750	.353	.700	-.135	-.146	-.577	.170
12	-.238	.103	.438	.112	.376	.124	.349	.210	.190	.092
13	-.036	.044	.237	.206	.678	.449	-.407	-.025	-.367	-.381
14	-.075	-.034	-.124	-.065	-.216	-.086	.184	.101	.195	.246
15	-.024	-.300	-.310	-.313	-.329	-.366	-.107	-.000	.119	-.064
16	-.276	.107	.219	.154	.293	.222	-.225	-.050	-.364	-.042
17	-.168	-.227	-.177	-.215	-.156	-.228	-.219	-.027	-.079	-.082
18	.168	.279	.089	.167	-.027	.132	.487	.140	.241	.399
19	.218	.005	-.052	-.030	-.066	-.010	.316	.131	.365	.095
20	-.075	.341	.170	.241	.041	.169	.207	.011	-.167	.388
21	-.050	-.150	-.141	-.248	-.166	-.261	.279	.766	.405	.085
22	-.056	.119	.109	.143	.111	.166	-.081	.645	-.129	-.012
23	-.600	.449	.221	.355	.110	.273	-.027	-.092	-.686	.496
24	.009	-.076	.133	.069	.182	.064	-.397	-.082	-.392	-.321
25	-.030	.310	.449	.396	.514	.486	-.094	.048	-.323	-.092
26	.043	.758	.767	.615	.492	.490	.692	.046	-.160	.655
27	.495	.616	.719	.555	.482	.464	.675	.053	.100	.430
28	.600	-.449	-.221	-.355	-.110	-.273	.027	.092	.686	-.496
29	.038	.753	.693	.711	.441	.588	.429	-.053	-.458	.655
30	.749	.624	.592	.564	.360	.461	.592	-.041	.063	.405
31	1.000	.131	.091	.146	.021	.118	.263	-.074	.352	-.052
32		1.000	.766	.918	.567	.805	.338	-.038	-.407	.454
33			1.000	.868	.845	.821	.149	-.038	-.459	.114
34				1.000	.734	.944	.046	-.097	-.511	.129
35					1.000	.854	-.108	-.055	-.478	-.135
36						1.000	-.079	-.092	-.505	-.017
37							1.000	.161	.469	.804
38								1.000	.227	.057
39									1.000	.023
40										1.000

Table 5.7 (continued)

VARIABLE NUMBER	41	42	43	44	45
1	.313	.334	-.208	-.254	.333
2	-.006	-.091	.291	.340	-.325
3	.242	.269	-.049	-.068	.151
4	.252	.046	.003	.228	.048
5	.181	.474	-.131	-.542	.235
6	.202	.485	-.137	-.548	.273
7	.249	.369	-.029	-.161	.070
8	.118	.179	.090	.011	-.216
9	-.071	.054	.133	-.021	-.243
10	.154	.191	-.242	-.247	.803
11	.683	.655	-.680	-.656	.739
12	.049	.063	-.120	-.076	-.144
13	.092	.218	-.227	-.413	.385
14	.018	-.023	.007	.137	.002
15	-.274	-.259	.187	.172	-.272
16	-.011	.071	-.278	-.316	.288
17	-.264	-.207	.030	-.004	-.105
18	.328	.163	-.031	.119	.141
19	.126	.026	.091	.196	-.009
20	.242	.161	-.157	-.099	.167
21	-.167	-.271	.089	.177	-.286
22	.124	.112	-.183	-.226	.261
23	.108	.048	-.672	-.458	.348
24	-.029	.153	-.019	-.245	-.170
25	.272	.338	-.283	-.375	.382
26	.591	.451	-.234	-.080	.110
27	.744	.651	.074	.069	.062
28	-.108	-.048	.672	.458	-.348
29	.735	.641	-.429	-.321	.370
30	.843	.739	.192	.140	.133
31	.527	.486	.579	.369	-.030
32	.868	.765	-.483	-.421	.529
33	.671	.751	-.312	-.463	.316
34	.833	.884	-.456	-.504	.583
35	.597	.638	-.304	-.455	.440
36	.748	.843	-.431	-.511	.677
37	.350	.046	.159	.444	-.174
38	-.048	-.131	-.050	-.010	-.051
39	-.220	-.349	.592	.773	-.416
40	.341	.027	-.202	.126	.051
41	1.000	.916	-.246	-.283	.489
42		1.000	-.236	-.361	.501
43			1.000	.840	-.497
44				1.000	-.488
45					1.000

The first regression analysis was made on soil water recharge due to snowmelt. The regression summary appears in Table 5.8. The strongest independent variable, explaining about 20% of the variance in snowmelt recharge, was a four-variable interaction, composed of the products of mean vegetation height (measured at microwatersheds by Knight [1971]), slope position (ranked by AOV tests), slope gradient, and site exposure to prevailing winds. The remaining four variables together explained only an additional 14% of the variance.

Table 5.9 is the summary for the second analysis, where soil water recharge due to spring rainfall was the dependent variable. Here again an interaction term was the strongest variable. The slope position, ranked previously from AOV tests, was divided by the product of slope gradient and grazing intensity; the resulting variable explained 12% of the variance in rainfall recharge. Percent sand in the C-horizon explained an additional 9%. Six more variables together explained only 18% of the variance in rain recharge. It is interesting to note that slope gradient, grazing, and surface bulk density were all negatively correlated with rain recharge, suggesting possible differences in infiltration between sampling sites.

Oddly enough, % sand in the C-horizon was the first variable entered in the third regression analysis, where total soil water recharge was the dependent variable. It is difficult to understand why variable X(9) should explain so much of the variability in both rainfall recharge and total recharge. It is possible that the amount of sand in the C-horizon is strongly related to some property of the soil surface which is controlling the infiltration rate. It is evident

Table 5.8. Regression summary for snowmelt recharge.

REGRESSION SUMMARY TABLE			
<u>Variable Entered</u>	<u>r</u>	<u>R²</u>	<u>Increase in R²</u>
X (36)	.447	.200	.200
X (22) H2Ø B	.242	.229	.029
X (9) C SAND	.186	.265	.035
X (7) A SAND	.101	.315	.051
X (38) H2Ø A + H2Ø B	.004	.338	.023

Table 5.9. Regression summary for rainfall recharge.

REGRESSION SUMMARY TABLE			
<u>Variable Entered</u>	<u>r</u>	<u>R²</u>	<u>Increase in R²</u>
X (44)	.340	.116	.116
X (9) C SAND	.299	.209	.094
X (11) SLOPE	-.141	.249	.040
X (5) GRAZ	-.236	.284	.035
X (31) PØS (RR)	.262	.323	.038
X (14) SFCBD	-.024	.354	.031

in this analysis that the same factors important in recharge by snow-melt are also important in the total recharge of soil water. As Table 5.10 shows, even though ten independent variables were entered into the model, only 38% of the variance was explained.

The soil water depletion regression models fared much better. Table 5.11 shows that the total amount of pre-growing season recharge experienced at the sampling sites explained nearly 40% of the variance in total evapotranspiration for the growing season. Grazing intensity explained another 17%. The slope position variable (ranked from AOV tests) and the slope gradient X aspect interaction together explained an additional 6%. This resulted in 63% of the variability in total evapotranspiration having been explained by only four independent variables.

The model for early evapotranspiration was much more complex. It took seven variables to explain a mere 66% of the variability in early ET. Again, total soil water recharge was the strongest variable, accounting for over 35% of the variance (Table 5.12).

The sixth regression analysis was performed on late season evapotranspiration, or those ET losses occurring between June 24 and August 20, 1971. Included in the independent variables was early season ET. Interestingly enough, this variable accounted for nearly 20% of the variability in late season ET (Table 5.13). This dependence suggests that water may have become limiting to plant use as early as June 24, since the two variables were negatively correlated. An interaction term, slope position ranking divided by grazing intensity, explained an additional 19% of the variance. Total soil water recharge again was important, adding 0.132 to the R^2 value.

Table 5.10. Regression summary for total recharge.

REGRESSION SUMMARY TABLE				
<u>Variable Entered</u>		<u>r</u>	<u>R²</u>	<u>Increase in R²</u>
X (9)	CSAND	.327	.107	.107
X (41)		.292	.207	.100
X (22)	H2Ø B	.182	.240	.033

X (8)	BSAND	.101	.254	.014
X (13)	EXPØS	.219	.269	.015
X (42)		.269	.292	.023
X (36)		.296	.300	.008
X (31)	PØS (RR)	.189	.335	.034
X (35)		.229	.359	.024
X (33)		.233	.381	.022

Table 5.11. Regression summary for growing season evapo-transpiration

REGRESSION SUMMARY TABLE				
<u>Variable Entered</u>		<u>r</u>	<u>R²</u>	<u>Increase in R²</u>
X (3)	RG (T)	.632	.399	.399
X (5)	GRAZ	-.303	.571	.172
X (27)	PØS (TD)	.346	.608	.037
X (45)	ASPECT * SLOPE	.141	.625	.017

Table 5.12. Regression summary for early evapo-
transpiration.

REGRESSION SUMMARY TABLE				
<u>Variable Entered</u>		<u>r</u>	<u>R²</u>	<u>Increase in R²</u>
X (3)	RG (T)	.594	.353	.353
X (39)	PØS(D1)/GRAZ	.365	.484	.131
X (2)	RG (R)	.550	.539	.055
X (8)	B SAND	.281	.568	.029
X (45)	SLØPE X ASPECT	-.009	.596	.029
X (5)	GRAZ	-.216	.618	.022
X (28)	PØS (D1)	.253	.661	.042

Table 5.13. Regression summary for late evapo-
transpiration.

REGRESSION SUMMARY TABLE				
<u>Variable Entered</u>		<u>r</u>	<u>R²</u>	<u>Increase in R²</u>
X (19)	P + D1	-.433	.187	.187
X (40)	PØS(D2)/GRAZ	.388	.373	.186
X (3)	RG (T)	.006	.505	.132
X (9)	C SAND	-.283	.548	.043
X (7)	A SAND	.004	.559	.011

Interpretations of the above results are discussed in detail in Chapter VI. In general, it appears that evapotranspiration is highly dependent upon soil water recharge. This is understandable for the dry soil water regime which exists on the shortgrass prairie. The low R^2 values for the soil water depletion runs were probably related, then, to the low R^2 values for the recharge runs. The large amount of unexplained variability in total soil water recharge was, no doubt, reflected in the depletion R^2 values. The source of this unexplained variance will be discussed also in Chapter VI.

CHAPTER VI

SOIL WATER BALANCE OF THE LYNN LAKE WATERSHED

In many cases one and the same thing is attracted by two strong forces, namely, Necessity and Potency. Water falls in rain; the earth absorbs it from the necessity for moisture; and the sun raises it, not from necessity, but by its power.

Leonardo da Vinci

The results of this soil water study are similar to and tend to support the results of Galbraith's (1971) intensive study of the water balance of the microwatersheds. Snow retention and the resulting soil water recharge due to snowmelt are obviously very important factors in the assessment of the soil water balance of a shortgrass prairie site. Accordingly, a substantial portion of this thesis has focused on the winter hydrologic regime of the Pawnee Site.

The Winter Hydrologic Regime

The writer attempted to observe snow accumulation and snowmelt characteristics on the study site following every major snowstorm of the 1970-71 winter. One storm in particular, that of January 1-3, 1971, was ideal for study purposes. Precipitation gage catch averaged 1.4 cm for the three-day storm. Scattered measurements of snow depth and water equivalent were taken immediately following the storm and again two weeks later just prior to melting of the snowpack. As discussed previously in a technical report (Van Haveren and Galbraith 1971), these data showed snow retention patterns brought about by topographic and vegetational differences. Furthermore, patterns in soil water recharge resulting from the storm suggested there was a control due to frozen

soil characteristics. Bottomland, south-facing, and west-facing sites received, in the form of soil water, a greater proportion of their snow-pack water equivalent than upland, north-facing, and east-facing sites. Although no overland flow was ever observed during the melt period, ponded water was evident in micro-depressions on all sites except those having steeper slopes. The bottomland sites, in particular, had free water standing on the surface during the first day of the melt period. Because December, 1970, was a cold, snow-free month for the Pawnee Site, frozen soil was encountered at depths up to 30 cm on some sites. Because of microclimatic variability, soils on the traditionally warmer south and west aspects may have been frost-free at the surface, allowing water to infiltrate these soils. This is a plausible explanation for the greater recharge on the west and south aspects. It is suggested that frost penetrometer measurements may be an important parameter to include in the hydrologic process studies. Occasional readings with a frost penetrometer on different aspect X slope gradient X slope position combinations may provide information on the possible existence of overland flow during snowmelt. Micro-runoff collectors installed on selected slopes and draining microwatersheds of known area should also be considered. On the basis of personal field observations, it is suggested that overland flow of snowmelt is a highly restricted and localized phenomenon, occurring only on steeper north- and east-facing slopes.

Given the low relative humidities, high winds, and clear sunny days characteristic of the Pawnee Grasslands during winter, it is understandable that evaporation and sublimation account for a significant portion of the total wintertime water balance. It was estimated in Chapter V that wintertime evaporation amounts to approximately 3.0 cm.

As a check on this estimate, a mean daily loss was computed from data collected from the weighing lysimeter located on the Pawnee Site. Since the lysimeter was not operable until the 1971 field season, these data are from the winter of 1971-72. For the period October 1, 1971 to March 8, 1972, the mean daily loss was 0.11 mm. Thus, the estimate of 0.15 mm day^{-1} given in Chapter V is a reasonable approximation.

The estimated water balance for the winter period, 1970-71, is then

$$P = \Delta S + E - \Delta \theta$$

$$(+10.5) = (+3.4) + (+3.0) - (-4.0) ,$$

where the + 3.4 value associated with the ΔS term indicates that approximately 3.4 cm of water was lost as a result of snow being blown off the sampling sites. It is likely that this figure is underestimated since gage catch of snow is often considerably less than that which reaches the ground.

Effects of topography and vegetation height on snow retention. In the analyses of variance results presented in Chapter V, a slope position X grazing interaction effect was found to be influential in the snow retention process. On the heavily-grazed transect, more snow was retained at the lower slope positions, while on the moderately-grazed and lightly-grazed transects, the greatest snow retention occurred at the middle 1/3 and upper 1/3 positions, respectively. There are several possible explanations for this pattern in snow accumulation. First, the slope position at which snow retention is maximized is dependent upon the slope length and gradient. On the longer and less steep slopes, the middle and upper slope positions will likely accumulate

more snow than the lower slope positions. Likewise, on short and steep slopes, maximum snow retention will occur at the lower slope positions. In general, however, the topography on the heavily-grazed transect is more subdued than on either the moderately-grazed or lightly-grazed transects. Hence, the slope gradient and slope length effects do not appear to be operating in this case. Another possible explanation for the slope position difference is the influence of vegetation height on snow retention. Theoretically, if we hold slope gradient and slope length constant and examine the effect of vegetation height, we should find that on slopes where vegetation is taller, snow retention increases in an upslope direction. This explanation may apply to the situation in this study, since the moderately-grazed and lightly-grazed transects retained more snow at the middle and upper slope positions than at the lower positions. However, as Knight (1971) pointed out, the differences in mean vegetation height across grazing treatments is only about 1 cm (on the basis of microwatershed data, mean vegetation heights for the heavy, moderate, and light grazing treatments are 1.2, 2.3, and 2.3 cm, respectively, for growing season 1970). A more likely explanation for the slope position - grazing intensity effect is the influence of local topographic characteristics. For example, local peculiarities in topography upwind of one heavily-grazed transect segment tend to favor maximum snow accumulation at the lower slope position sampling site. The same factor appears to be operating on the middle position sites on the moderately-grazed transect.

A much more important interaction effect is due to the combination of vegetation height and several topographic variables which influence snow accumulation. The multiple product of the variables vegetation

height, slope position ranking, slope gradient, and exposure ranking explained 20% of the variance associated with snowmelt recharge. These results are interpreted to mean that sites found at the more steep lower and middle slope positions with a lee exposure in the lightly-and-moderately-grazed pastures are ideally suited for retaining large quantities of snow. The physical basis for this reasoning has been discussed previously. Obviously, a site located on a steep lee slope at the mid- to lower-slope positions has a very large potential storage volume for snow. Figures 6.1a-d portray this quite vividly. The relative strengths of each of the topographic variables included in the interaction term are not easily ranked on the basis of the regression results. Individually, these variables contributed very little (< 2%) to explaining the variability in snowmelt recharge. On the basis of the AOV test results in Chapter V, however, exposure appears to be the most important topographic factor influencing snow accumulation. The regression summary presented in Table 5.8 shows that four soil variables taken together explain an additional 14% of the variance associated with snowmelt recharge. Variable X (22) is defined as the water available (in % by volume) in the B-horizon between 0.3 and 15.0 bars matric potential. Reciprocally, and ignoring hysteresis effects, this variable may also be defined as an index of the water holding capacity between 0.3 and 15.0 bars matric potential. Variables X (9) and X (7) are, respectively, the percent sand by weight in the C and A horizons. Variable X (38) is the sum of available water in the A and B horizons. Since soil type and slope position are quite interrelated on the Pawnee Site, it appears that these variables are serving as an index to slope position. This hypothesis can be supported by close examination of the hydrologic and



Figures 6.1a-b. Photographs showing the effects of exposure and slope position on snow accumulation on the shortgrass prairie.



Figures 6.1c-d. Photographs showing the effects of exposure and slope position on snow accumulation on the shortgrass prairie.

physical properties of the common soil types. At the slope positions where snow retention is maximized, the most common soil types are Renohill sandy loam, Shingle loam, and Shingle-Renohill complex. From Tables 3.2 and 3.3 it is readily apparent that the Renohill and Shingle soils have the greatest amount of available water in the B horizon of all the soil types shown. Thus, there appears to be an indirect relationship between the soil variables and snowmelt recharge, owing to the interdependence of slope position and soil type.

Grazing intensity (or mean vegetation height) alone did not contribute significantly to the regression on snowmelt recharge. Nor did it even appear a significant effect in the analysis of variance tests on snow retention. Nevertheless, as shown in Figure 5.3, there is a trend of increasing snow retention with decreasing grazing pressure (or increasing vegetation height). The lack of statistical significance is attributed to the very small differences in mean vegetation height across grazing treatments. This corresponds with Galbraith's (1971) results, where the grazing effect upon snow retention was felt only between the non-grazed and heavily-grazed microwatersheds. Where vegetation differences are substantial on the prairie, a strong control on snow retention results. The study of Willis et al. (1969) strongly supports this theory.

The 5-variable regression analysis summarized in Table 5.8 shows that a total of only 33% of the variance associated with snowmelt recharge was accounted for. Since all possible mesotopographic, soil, and grazing variables were included in the regression analysis, the source of the unexplained variance is not immediately obvious. It has been suggested earlier in this chapter that local differences in

topography were responsible for the strong slope position X grazing intensity interaction effect on snow retention. It is also possible that local variation in vegetation height may affect the snow accumulation characteristics of certain sampling tubes. For example, an increase in the frequency of tall forb species or shrubby vegetation immediately upwind of a sampling site may drastically influence the water balance of that site by increasing snow accumulation. A recent spring snowstorm on the Pawnee Site afforded an exceptional opportunity to visually examine this possibility. Figures 6.2a through 6.2d document those field observations. The presence of scattered individual shrubs significantly influences snow accumulation of an area as distant as 5 meters leeward of the plants. Another possible source of unexplained variance in snow accumulation was suggested and studied by Froehlich (1969). Although the study was made in an alpine-subalpine situation, many of the physical processes associated with snow accumulation in this zone apply as well to the prairie situation. Froehlich was able to show that the areal extent of a source area for blowing snow and its distance from the sampling site, were extremely important in explaining snow accumulation patterns. On the prairie such source areas are not as easily identified. Since snow accumulates differentially upwind of a given sampling site, according to topographic and vegetational controls, the amount of blowing snow potentially available for accumulation can be expected to vary from site to site. However, personal observations of prairie snowstorms suggest that the source area effect is not strongly operative on the prairie. It is strongly suggested that local peculiarities in vegetation height and in microtopography are largely responsible for the snow accumulation patterns and resulting snowmelt recharge



Figures 6.2a-b. Photographs showing the effect of vegetation height on snow accumulation on the shortgrass prairie.



Figures 6.2c-d. Photographs showing the effect of vegetation height on snow accumulation on the shortgrass prairie.

patterns found on the shortgrass prairie. Mean vegetation height and mesotopographic variables influence spatial patterns in snow accumulation to a lesser extent. When mesotopography becomes more exaggerated, however, such as with a prairie landscape characterized by steep slopes and eroded gullies, mesotopographic factors assume more control over snow accumulation patterns.

The recharge ratio. As an index to the importance of snow accumulation to the water balance of a given site, and as an indicator of site characteristics favorable to snow accumulation, a parameter termed the "recharge ratio" was devised. This index is simply the ratio of the total soil water recharge due to snowmelt to the total soil water recharge received between growing seasons, and is expressed symbolically as

$$\theta_r = \frac{\Delta\theta_s}{\Delta\theta_T} \quad [6.1]$$

Both analysis of variance and multiple regression tests were performed on the recharge ratio, which was computed for each sampling site. Both exposure and grazing intensity were found to be highly significant effects when each was combined with slope position in analysis of variance tests. The AOV tables are shown in Table 6.1. Leeward sites were found to have a θ_r value of 0.54 compared to 0.41 for windward sites. The θ_r values for the grazing treatments were 0.40, 0.49, and 0.55, for the heavily-grazed, moderately-grazed, and lightly-grazed transects, respectively. These results were somewhat supported by the regression analysis (Table 6.2), where an interaction variable, mean

Table 6.1a-b. AOV tables representing the (a) slope position X exposure and (b) slope position X grazing intensity models. The recharge ratio, θ_r , is the response variable.

ANALYSIS OF VARIANCE TABLE

Table 6.1a

<u>Source</u>	<u>df</u>	<u>SS</u>	<u>MS</u>	<u>F</u>
Mean	1	13.7665		
Slope position	4	0.1193	0.0298	1.41
Exposure	1	0.2578	0.2578	**12.16
Interactions	4	0.0423	0.0106	0.50
Within	50	1.0601	0.0212	
Total	60	15.2368		

**Significant at 0.99 level

Table 6.1b

<u>Source</u>	<u>df</u>	<u>SS</u>	<u>MS</u>	<u>F</u>
Mean	1	13.7665		
Slope position	4	0.1427	0.0357	1.70
Grazing	2	0.2695	0.1347	**6.42
Interactions	8	0.1457	0.0182	0.87
Within	45	0.9450	0.0210	
Total	60	15.2368		

**Significant at the 0.99 level

Table 6.2. Regression summary for the analysis of the recharge ratio. The regression AOV, regression coefficients, and standard error of estimate are given in Appendix C. The test was significant at the 0.99 level.

REGRESSION SUMMARY FOR THE RECHARGE RATIO			
<u>Variable Entered</u>	<u>r</u>	<u>R²</u>	<u>Increase in R²</u>
X (35)	0.514	0.264	0.264
X (8)	-0.094	0.335	0.071
X (22)	0.271	0.358	0.024
X (7)	0.012	0.390	0.032
X (21)	-0.165	0.416	0.026

vegetation height X slope position X exposure, accounted for over 26% of the variance associated with the recharge ratio. An additional 15% was explained by four separate soil variables, again thought to be an index of the slope position effect. Although the AOV tests did not show slope position to be a significant effect, nevertheless, the pattern of mean recharge ratios as a function of slope position was similar to that found when analyzing snow retention patterns. Mean values for the five slope positions were 0.39, 0.46, 0.51, 0.53, and 0.48, for the ridgetop, upper slope, middle slope, lower slope, and swale sites, respectively. Although not statistically significant, the trend is for snowmelt recharge to assume more importance at the middle and lower slope positions and less importance at the ridgetop, upper slope, and bottomland sites.

It is interesting to note that the overall mean recharge ratio was 0.48 which is interpreted to mean that approximately 48% of the total soil water recharge occurring on the Pawnee Site between growing seasons is attributed to snowmelt. This is significant in that most of the growth experienced by the Pawnee Site vegetation is dependent upon the stored water already in the soil profile (i.e. recharge received since previous growing season). Consequently, snowfall may be said to be an important hydrologic input on the shortgrass prairie, despite the fact that it comprises only 10 to 15% of the mean annual precipitation. On many sites, where the recharge ratio exceeds 0.50, the associated vegetation is probably more dependent upon snowmelt than upon fall and spring rains for survival and growth. On some optimum sites snowmelt recharge contributes over 70% to the total soil water recharge occurring prior to the growing season.

In summing up the above discussion, it must be concluded that snow is a valuable input to the hydrologic balance of the shortgrass prairie. The results of this study may even have underestimated its importance, since Striffler (1972) reports that the 1971 winter precipitation was below normal and the April rainfall was above normal.

Soil Water Recharge by Rainfall

The results of the AOV tests on rainfall recharge are difficult to interpret because of the addition of evapotranspiration to runoff in the response variable. Significant evapotranspiration most certainly occurred during the rainfall recharge period, and this ET may have been spatially variable. Thus, it would be highly presumptuous to use the results of the rainfall recharge AOV without breaking out the runoff term and using it as the simple response variable. In the regression analysis, the dependent variable was simply soil water recharge due to rainfall, uncorrected for differences in measurable precipitation. The regression results are somewhat more revealing than the AOV results. The strongest independent variable entered was an interaction variable: slope position (ranked according to increasing rainfall recharge) divided by the product of slope gradient and grazing intensity. This variable accounted for approximately 12% of the variance associated with rainfall recharge. Variable X (9), the percentage of sand in the C horizon, explained nearly as much variance as variable X (44). As with the snowmelt recharge regressions, this soil variable is thought to be an index of slope position and/or slope gradient. Three more variables, slope gradient, grazing intensity, and slope position, each added roughly 4 percentage points to the final multiple determination coefficient. The simple r values associated with each of these

variables are worthy of discussion. Slope gradient and grazing intensity were both negatively correlated with rainfall recharge, suggesting that overland flow may have occurred on the steeper slopes, particularly on the heavily-grazed transect. As expected, slope position was positively correlated with rainfall recharge, but not strongly so. Although it only accounted for 3% of the variance, surface bulk density was negatively correlated with recharge, as one might expect. Despite the lack of rigid statistical significance in the above results, there is nevertheless a hint of isolated overland flow events influencing spatial patterns in rainfall recharge. Since the major rainfall recharge period analyzed did not include any significantly large precipitation events, the statistical results are not surprising. Under ideal conditions, i.e. high surface bulk densities, steep slopes, and poor range condition, rain rate could frequently exceed the infiltration rate, resulting in overland flow and decreased soil water recharge. During some years when high intensity storms are more frequent, an effect of slope position on soil water recharge may become clearly evident.

Because of the rather uniform spatial distribution of soil water recharge during the rainfall period, the spatial distribution of total soil water recharge occurring prior to the growing season was largely dependent upon the patterns of recharge originating as snowmelt. The statistical results of total recharge, in fact, were nearly identical to those of snowmelt recharge. The simple correlation coefficient for snowmelt recharge vs. total recharge was 0.866. Rainfall recharge was less strongly related to total recharge ($r = 0.357$).

Soil Water Depletion and Evapotranspiration

If we neglect the runoff term in equation [5.4], evapotranspiration may be calculated from knowledge of P and $\Delta\theta$. Evapotranspiration then includes depletion of both long-term and short-term storage of soil water by evaporative and transpirative processes, and evaporative losses of water intercepted by vegetation and litter surfaces. The mean $\Delta\theta$, averaged over the 60 sampling sites, for the growing season was 9.4 cm of water. Mean precipitation for the growing season was 5.7 cm. Since a considerable portion of the 5.7 cm is not available for plant use, it is apparent that the transpiration portion of ET is largely dependent upon the long-term storage of soil water, or that recharge received prior to the growing season. Consequently, one would expect the magnitude of ET losses to be highly dependent upon soil water recharge received from fall, winter, and spring precipitation. The regression analysis of growing season ET supports this theory. Variable X (3), total recharge received prior to the growing season, explained nearly 40% of the variability in growing season ET. Moreover, the simple r value for X (3) shows that the dependency was strongly positive. In essence, this finding supports the general assumption that soil water is a limiting factor in the shortgrass prairie ecosystem. The grazing intensity variable adds an additional 17 percentage points to the final multiple determination coefficient ($R^2 = 0.625$). The fact that grazing intensity is negatively correlated with ET supports Galbraith's (1971) results, in that the increased ET on the lightly-grazed and moderately-grazed transects resulted from the greater snowmelt recharge experienced by those sites. Likewise, the pattern of ET with regard to slope position is similar to the pattern of snow accumulation. The dependency

of growing season ET on total soil water recharge can be seen by comparing Figures 5.3 and 5.9. It is interesting to note that the aspect X slope gradient interaction was the fourth variable entered in the regression analysis of total ET. Although the simple correlation coefficient ($r = 0.141$) shows the relationship to be a weak one, nevertheless, the steeper and traditionally warmer slopes experience the greater evapotranspiration.

Breaking the growing season into early vs. late depletion periods did not significantly affect R^2 values. Of the total variance associated with early ET, only 66% was explained by some seven variables. Strongest of these was total soil water recharge again, which by itself explained 35% of the variance. An interaction term, slope position ranking divided by grazing treatment, explained an additional 13%. It is interesting to note that recharge due to spring rainfall was the third variable entered. Although it accounts for only 5.5% of the variance in early ET, it suggests, however, that patterns in spring rainfall recharge have some effect on early ET, since this water is stored in the surface portion of the soil profile. In the regression analysis of late (June 24 to August 20) evapotranspiration, early ET was included as an independent variable. This variable, negatively correlated with late ET ($r = -0.433$), explained nearly 20% of the variance associated with late ET. This is interpreted to mean that those sites which had high depletion rates prior to June 24 had lower rates during the late depletion period, and vice-versa. This may be an indication of a phenological control acting on plant water use. It also seems to suggest that on some sites actual evapotranspiration decreased below potential evapotranspiration as early as June in 1971. Table 5.13 shows

that the slope position X grazing intensity interaction, as well as the total recharge, had an influence on late Et. The soil variables which appear in all the depletion regression analyses again seem to be inter-related with slope position.

As with the results of the regression analyses of the recharge variables, the low R^2 values associated with the depletion regressions were disappointing. In the case of growing season ET, the source of unexplained variance is considered to be the local variability in species composition and ground cover properties. Nor can one forget the possibility of lateral soil water redistribution following the winter and spring recharge periods. Lateral redistribution downslope is possible when soils are near saturation. If extensive redistribution were to have occurred on some steep slope sites, the relationship between total recharge and total ET would be affected. However, the local variability in vegetative characteristics, litter depth, and perhaps hydraulic conductivity of the soil in the root zone, all of which were variables not adequately accounted for, probably was responsible for the low R^2 values.

If nothing else, this study serves to point out that soil water recharge and depletion are highly complex processes, even on the short-grass prairie where vegetation cover is relatively homogeneous and topography much subdued.

CHAPTER VII
RESULTS OF THE SOIL WATER
POTENTIAL STUDY

*The best measure of the availability of (soil) water
to plants is the water potential*

*Paul J. Kramer
James B. Duke Professor of
Botany, Duke University*

At four locations, representing four soil types, along the moderately-grazed transect, soil psychrometers were operable at the five measuring depths throughout the 1971 growing season. This chapter will concern itself primarily with the results of the data obtained from those four installations.

Confidence Intervals for Field Soil Water Potentials

As an example of how reliable the psychrometer calibration was, confidence intervals were computed for a typical growing season curve of soil water potential. Table 7.1 shows the 95% and 99% confidence intervals for the 20 cm depth in the Shingle loam soil. From these data it can be concluded that the calibration model is the most reliable at the middle portion of the water potential range. The model is slightly more accurate at the wetter end than at the drier end. This is probably so because of the nonlinearity of psychrometer response found at the drier water potentials. The questionable accuracy of the soil psychrometer at the wet end suggests that this instrument may not be reliable for use in unsaturated flow determinations when potentials are more than about -2.0 bars. However, calibration models for single psychrometers may be considerably more accurate than the lumped model used in this study.

Table 7.1. Predicted soil water potentials and associated 95% and 99% confidence intervals for the 20 cm depth in Shingle loam for the 1971 growing season.

<u>Date</u>	<u>Upper Limit</u>		<u>Predicted</u>	<u>Lower Limit</u>	
	99%	95%		95%	99%
5-8-71	-0.8	-1.0	-1.4	-1.8	-1.9
5-18-71	-0.2	-0.3	-0.8	-1.2	-1.3
6-5-71	-0.2	-0.3	-0.8	-1.2	-1.3
6-10-71	-2.8	-2.9	-3.3	-3.7	-3.7
6-15-71	-7.9	-8.0	-8.4	-8.7	-8.8
6-21-71	-9.9	-10.0	-10.3	-10.7	-10.8
6-24-71	-18.4	-18.5	-18.9	-19.3	-19.4
7-1-71	-31.2	-31.4	-31.8	-32.3	-32.4
7-8-71	-39.0	-39.1	-39.6	-40.0	-40.2
7-15-71	-46.9	-47.1	-47.9	-48.6	-48.9
7-22-71	-58.2	-58.4	-59.1	-59.9	-60.1
7-29-71	-73.6	-74.0	-75.0	-76.1	-76.4

For soil-plant-water relations work, the technique used in this study appears to be quite adequate.

Soil Water Potentials on the Lynn Lake Watershed

Since the objective of this portion of the study was simply to evaluate the feasibility of using thermocouple psychrometers to measure soil water potentials in a wildland situation, possible treatment effects on soil water potential were kept to a minimum. Four soil types were chosen for study: Ascalon sandy loam, undifferentiated bottomland soil, Renohill sandy loam, and Shingle loam. Soil water potential as a function of depth and time for the four soils is presented in Figures 7.1 through 7.4. The most obvious characteristic common to all four figures is the considerable variation evident in the 2 cm curves. This is interpreted to indicate that the 2 cm soil depth is quite sensitive to the small short-duration thunderstorms typical of the growing season on the prairie. The 10 cm depth was apparently not affected by these rain events. In general, the curves for all depths assume the shape of typical water release curves. It is interesting to see that the 60 cm depth in most of the soils experienced an increase in water potential during mid-June. This is further evidence that redistribution of soil water occurs vertically in the downward direction, a phenomenon also evident in Figure 5.2b. By the end of July, water potentials in the top 20 cm at all four sampling locations fell below -70 bars, the approximate lower limit of the thermocouple psychrometer. At the Ascalon site, which, considering all soil horizons, was the coarsest soil type of the four, even the 60 cm depth reached -70 bars by August 1. On the Shingle loam site, water potentials below 20 cm remained above -40 bars. This is understandable since the Shingle soil has a high water-holding capacity.

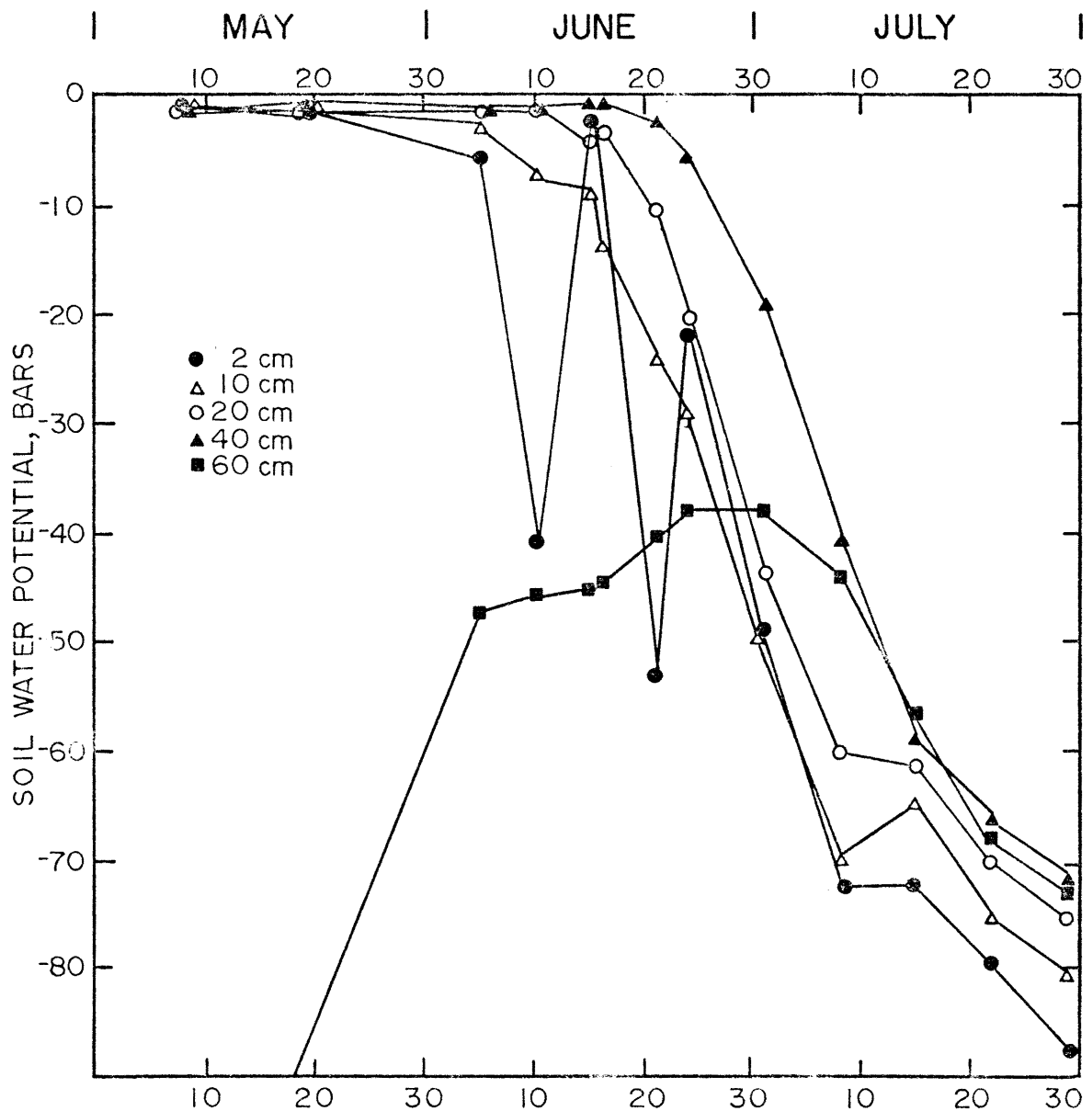

Figure 7.1. Soil water potential as a function of both depth and time for the Ascalon sandy loam site, 1971 growing season.

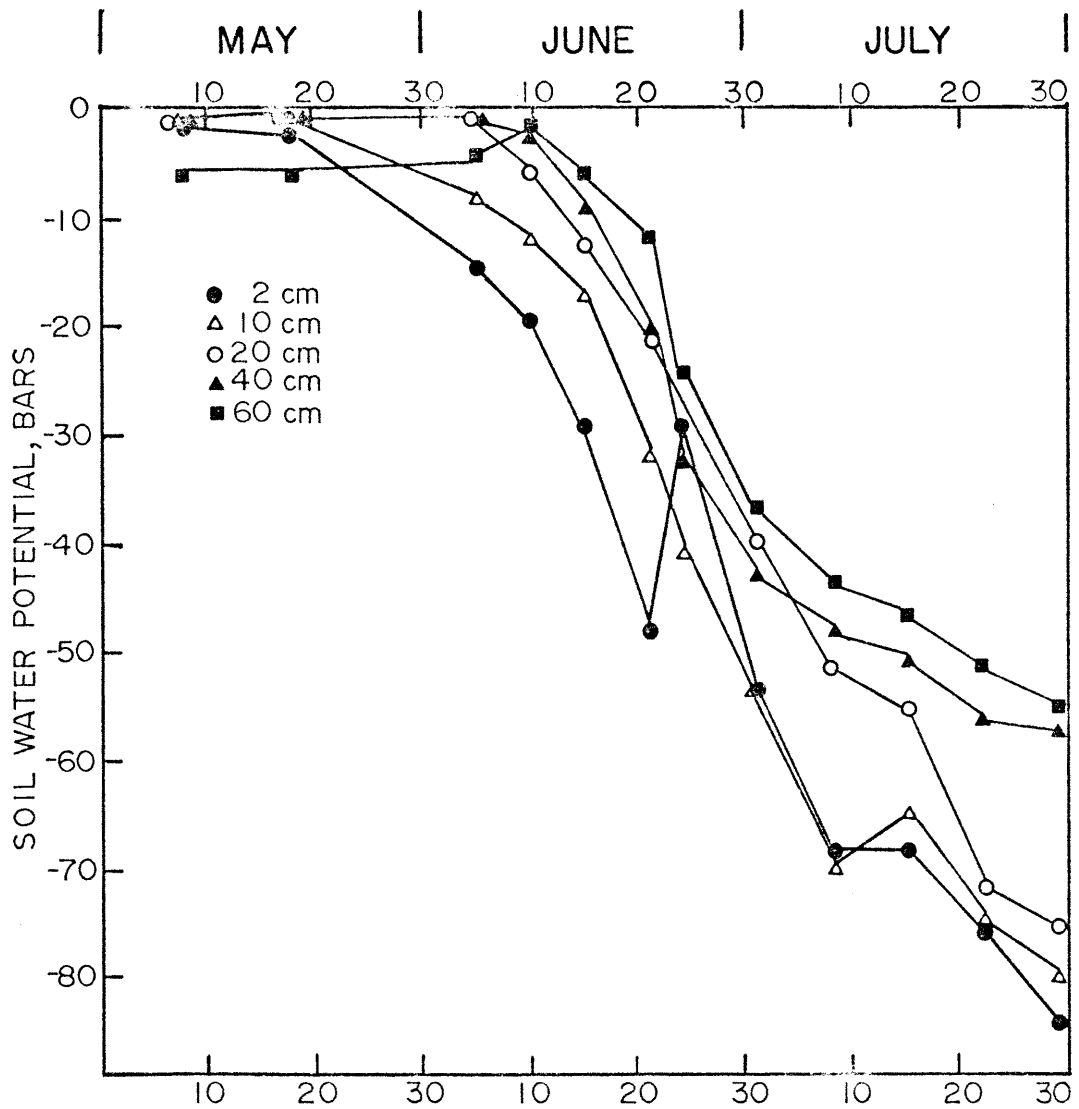

Figure 7.2. Soil water potential as a function of both depth and time for the undifferentiated bottomland soil site, 1971 growing season.

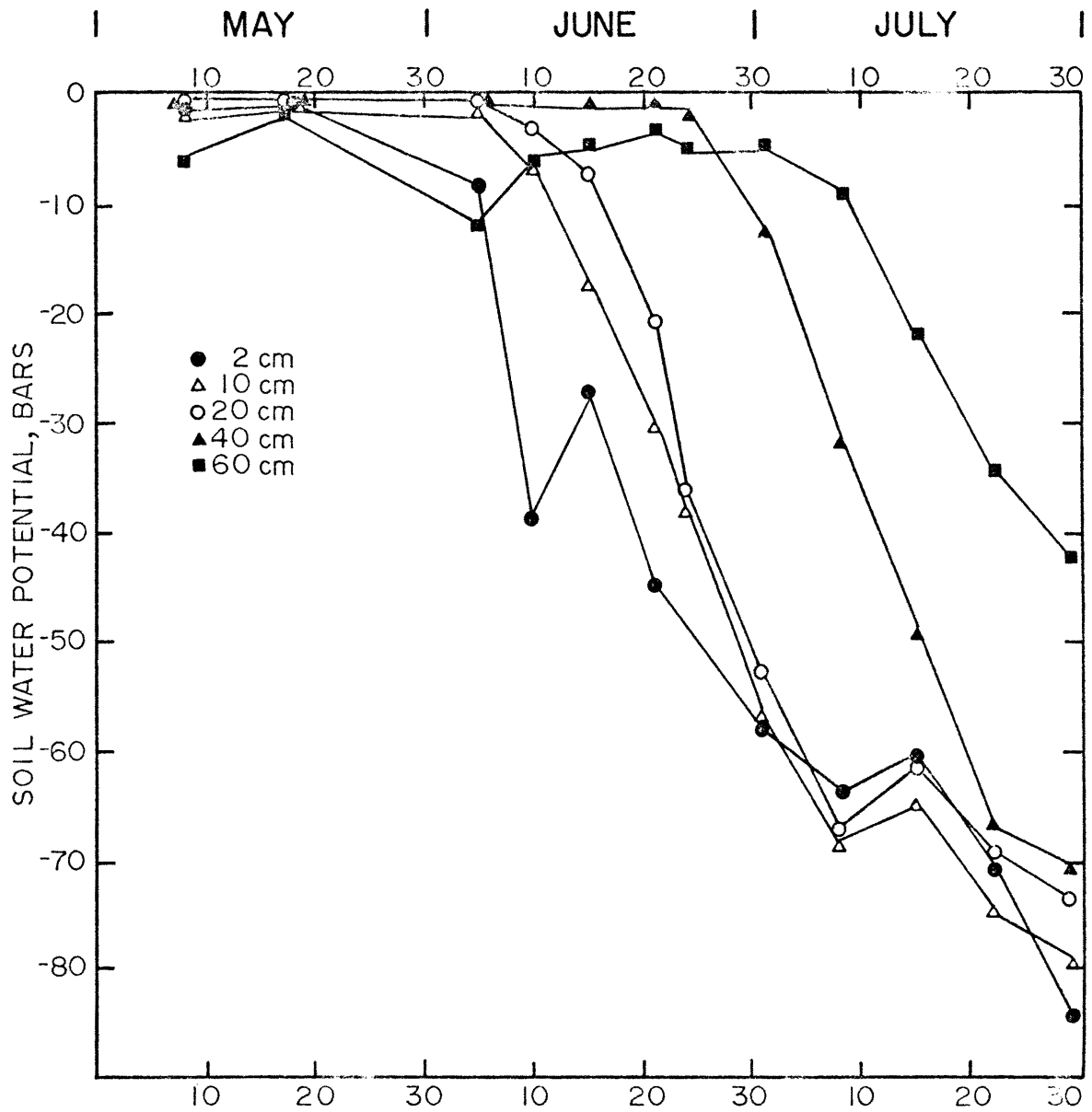

Figure 7.3. Soil water potential as a function of both depth and time for the Renohill sandy loam site, 1971 growing season.

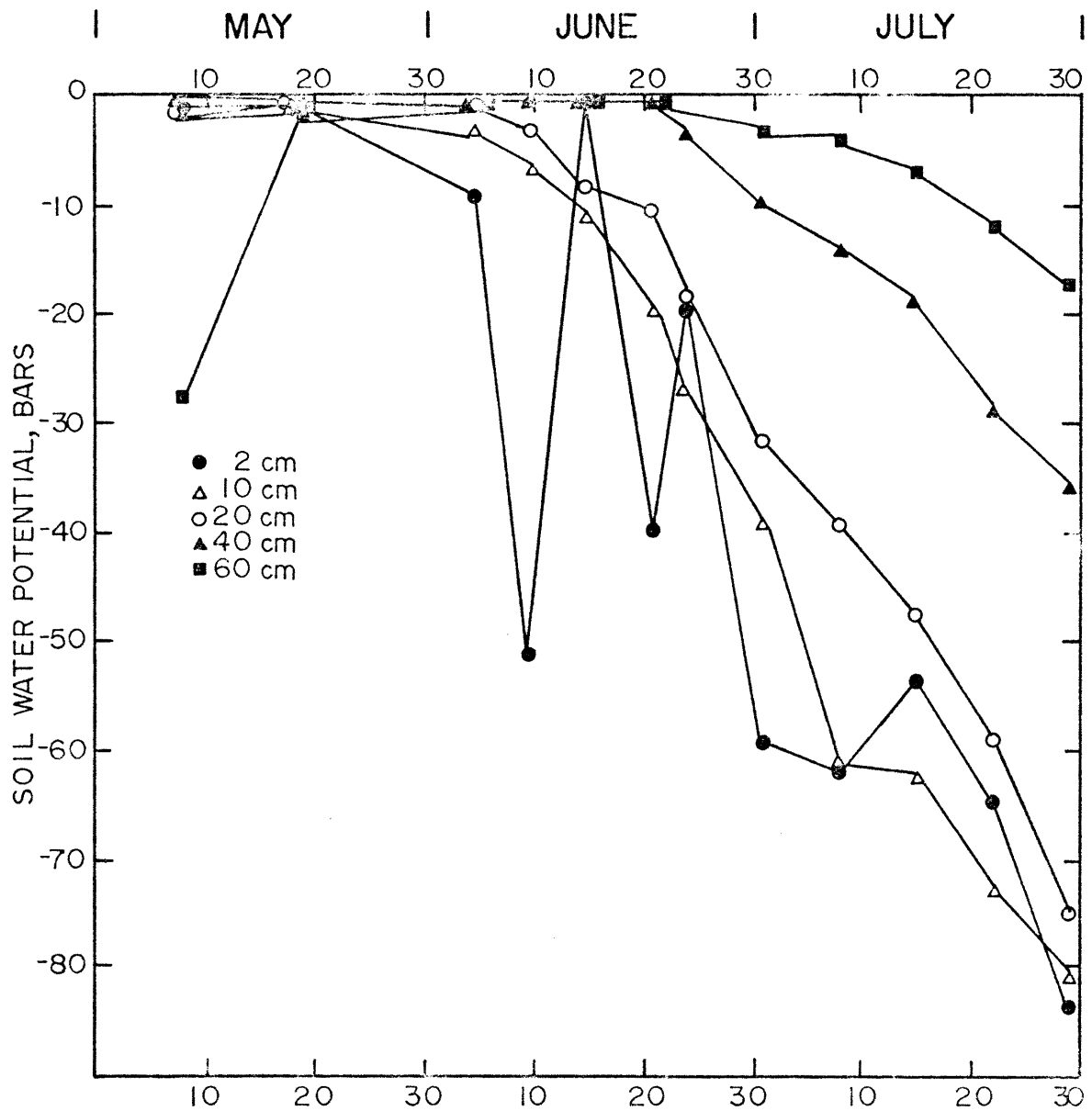

Figure 7.4. Soil water potential as a function of both depth and time for the Shingle loam site, 1971 growing season.

It was hypothesized early in this study that soil water potentials would likely reach very low levels by the end of the growing season. However, the fact that soil water potentials in the top 20 cm dropped below -70 bars by July 30 was somewhat surprising. It was even more startling to find that the 40 and 60 cm depths in some soils reached -70 bars by that date. These data clearly demonstrate the high evaporative demand characteristic of the shortgrass prairie in June and July.

This study represents one of the first attempts to measure *in situ* the soil water potential regime of a wildland site. Therefore, comparison of these data to previously published data is difficult. Recently, however, Shown et al. (1972) reported on soil water potential results obtained by the filter paper technique in western Colorado. Since the study area was in a semiarid sagebrush-grass vegetation type, some general comparisons can be made between the results of Shown et al. and the present study. The minimum soil water potentials measured under big sagebrush and bluebunch wheatgrass in 1971 occurred on August 3. The minimum values obtained for the 10, 20, 40, and 60 cm depths were roughly -100, -60, -40, and -35 bars, respectively. Thus, these results are very similar to those found in the present study. Both studies tend to support the current thinking of water relations scientists, that non-agricultural species of plants may be capable of surviving and even growing and actively transpiring under conditions of very low soil water potentials. The -15 bar limit, commonly called "permanent wilting point," may not apply to wildland vegetation, and a more realistic wilting point for species like blue grama may be on the order of -30 or -40 bars.

Applications of Soil Water Potential Data

Besides providing the most efficient link between soil water availability and the soil-dwelling organism in studies of ecosystem behavior, soil water potential data may be useful in soil water balance investigations.

Taylor (1952) suggested a method whereby time and depth variations of soil water potential in a soil profile could be represented by a single value, termed the mean integrated soil moisture tension. Taylor (1965) later makes the point that the significance of the mean integrated value to plant water use may be enhanced by differentially weighting critical depths and time periods. For example, the water potential of the surface depths of a soil profile may be more critical than at deeper depths. Likewise, the beginning of a growing season is probably more important, in terms of plant-water relations, than the latter part of the growing season. Bahrani and Taylor (1961) applied the mean integrated soil water potential concept in an evapotranspiration study. They found that water losses from alfalfa plots were linearly related to mean integrated water potential. As water potential decreased, evapotranspiration decreased, the linear correlation being nearly perfect. This scheme may represent a potentially useful approach to modeling evapotranspiration and plant growth over a growing season.

For most soils, the pressure and osmotic component of the soil water potential are negligible. Thus, the measurement obtained with a thermocouple psychrometer approximates the matric potential. In the case of saline soils, techniques are available whereby the osmotic component may be measured independently (Richards and Ogata 1961, Oster et al. 1969) and subtracted. With the concurrent use of

thermocouple psychrometers and a neutron soil water probe, soil water characteristic relationships, $\frac{d\theta}{d\psi_{\tau}}$, may be approximated for various depths in a soil profile. The experimental design used in this study permitted comparison of field soil water desorption curves with those obtained from pressure membrane data. Figure 7.5 compares the two curves obtained for the 40 cm depth in the Shingle loam soil. Further development of this technique may lead to more accurate estimates of the soil water diffusivity and hydraulic conductivity for field soils. Such measurements could be used as checks in field soil water characteristic models, such as that proposed recently by Rogowski (1971). Adequate field estimates of the hydraulic conductivity-water content and water content-matric potential relationships are badly needed for hydrologic studies involving field soils (Bruce 1972).

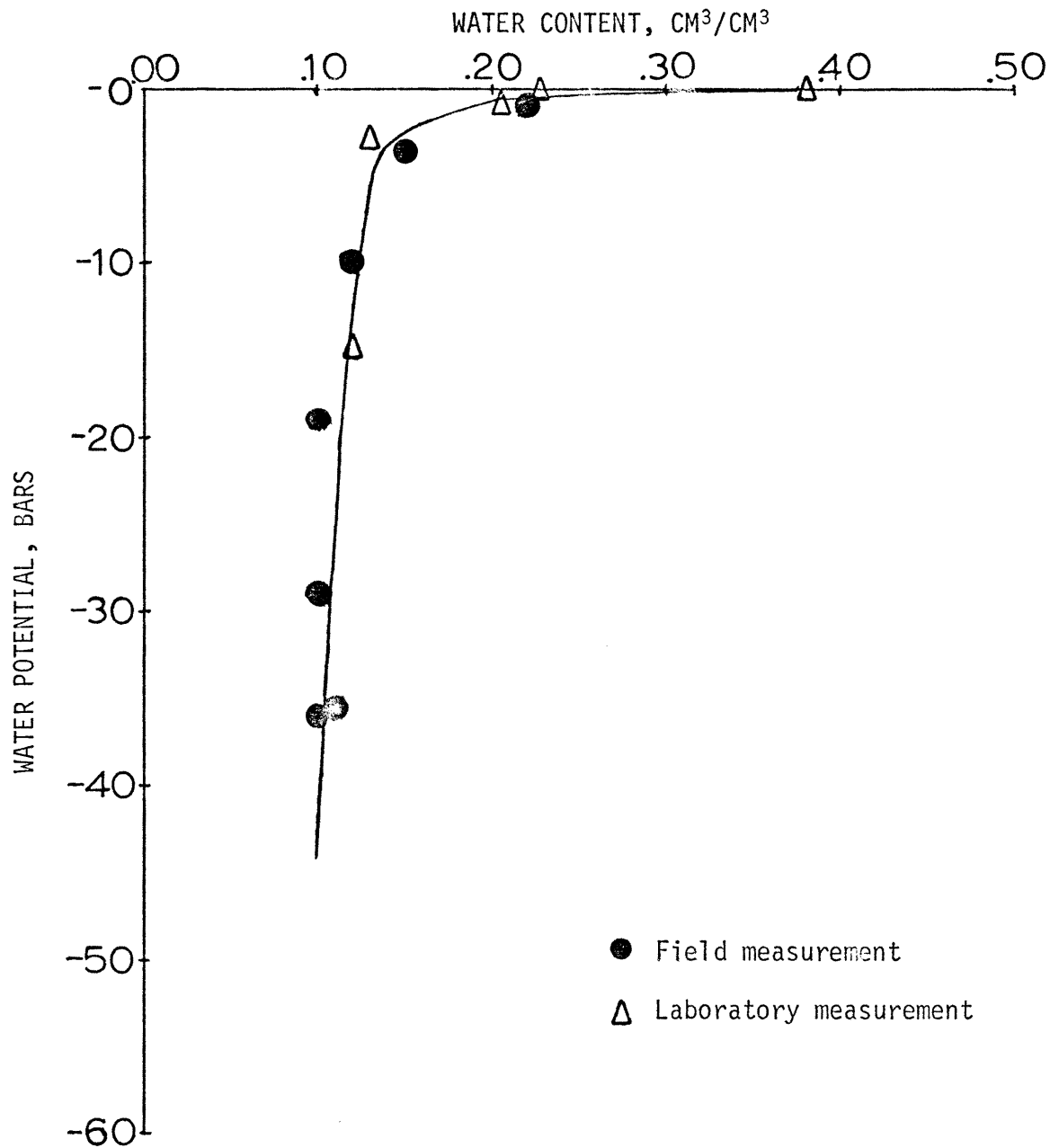

Figure 7.5. Comparison of field vs. laboratory soil water desorption curves for the 40 cm depth in Shingle loam soil.

CHAPTER VIII

SUMMARY, RECOMMENDATIONS, AND CONCLUSIONS

Nature is full of infinite causes that have never occurred in experience.

Leonardo da Vinci

This thesis has been concerned with the influence of topography and soil type on the recharge and depletion of soil water. The characteristics of the winter soil water regime have been discussed in some detail, particularly with respect to processes of snow retention by topographic and vegetative barriers and redistribution of snow by wind on the prairie. A preliminary study of soil water potential measurement was also reported on.

Summary of Results

Bulk density of the A and B horizons and textural breakdown of the A, B, and C horizons were determined for the six principal soils found within the Lynn Lake watershed, Pawnee Site, northeastern Colorado. Undisturbed samples from the A and B horizons of these soils were subjected to water retention analysis using the pressure plate method. In general, both the physical and hydrologic properties were quite similar between the soils. A grazing influence was related to surface bulk densities. Greatest densities occurred on the heavily-grazed transect; this relationship was enhanced on the heavier soils. In some cases inter-horizon differences in water retention properties were greater than inter-soil differences. This was particularly true for the Reno-hill sandy loam, which has a very sandy A horizon and much heavier B

horizon. This unique characteristic is probably responsible for this soil's ability to support a rather mesic site, by shortgrass prairie standards. In terms of topographic position, ridgetop, upper slope, and swale soils retained more water than did middle or lower slope soils at matric potentials between -0.3 and -15.0 bars.

A water balance for the study area was estimated for the winter period, 1970-71. In general, it appears that over 60% of the winter precipitation was lost to a combination of evapostublimation and wind transport of snow. It is highly likely that wind-transported snow accounts for over half of this loss. Despite this large loss, an average of 48% of the total soil water recharge received between growing seasons 1970 and 1971 was derived from snowmelt. On some sites having optimum snow trapping abilities, snowmelt accounts for over 70% of the total recharge.

Both topography and vegetative characteristics are important in the snow retention process on the prairie. Exposure to wind appears to be the most important topographic factor, with lee slopes receiving significantly more snowmelt recharge than windward slopes. Snow accumulation also varies with the position-on-slope. In general, the middle and lower slope positions are more efficient in trapping snow. However, the slope position effect seems to be dependent upon slope length and slope gradient, as well as on local peculiarities in the mesotopography of a given site. Vegetation height also determines snow accumulation patterns at a particular site. Because of the effect of mean vegetation height on snow retention, snowmelt recharge was greater on the lightly-grazed transect than on the moderately-grazed or heavily-grazed transects. Local peculiarities in vegetation height, particularly upwind of a

sampling site, will influence the snow accumulation patterns of that site to a great extent.

Soil water recharge resulting from spring rains did not vary much in a spatial sense. Under a regime of more frequent runoff-producing rain events, it is expected that slope gradient, slope position, and grazing effects would determine the spatial distribution of rainfall recharge. In summary then, it can be said that the spatial distribution of soil water recharge received between growing seasons on the prairie is largely dependent upon patterns of snow retention and redistribution.

Since actual evapotranspiration apparently fell below potential evapotranspiration early in the growing season in this study, patterns of soil water recharge had an important influence on the spatial distribution of evapotranspiration. This influence appeared to have overshadowed any soil effects on the growing season evapotranspiration.

The soil water potential data collected on the moderately-grazed transect further supports the idea that the soil water regime of the shortgrass prairie is indeed a dry one. By August 1, 1971, water potentials at depths above 40 cm had reached the -70 bar limit at most of the sampling locations. Soil water potential data may be used to advantage in several different ways. Besides being one of the best indices of soil water energy status, *in situ* measurements of soil water potential may eventually be used to estimate field values of the soil water characteristic relationship, the hydraulic conductivity, and the soil water diffusivity. Desorption curves developed using the *in situ* technique agree reasonably well with the curves obtained from pressure membrane data.

Recommendations

This study inherently lacked a rigid statistical sampling design. Although this type of design was attempted, a more efficient design could have been utilized. To study intensively the effects of topographic variables, several smaller transects located on representative slopes may have been used. Micro-runoff collectors, sampling a microwatershed of known area, should have been located at each sampling site, representing a different slope position. To test the effects of soil type, a statistical sampling design should have been used, holding topographic variables and grazing intensity constant. Additional measurements should include snow depth and water equivalent at each sampling site periodically following a snowstorm; frost penetrometer measurements taken periodically throughout the winter to test microclimatic variability; snow evaporation measurements; vegetation height and density and species frequency measurements within a 5 meter radius of each sampling site; and soil water potential and soil temperature measurements at every other sampling site. Improvements on the original design would probably have eliminated twenty to thirty sampling sites, and allowed for a more intensive study of soil type and topographic effects upon the soil water balance.

Much more information is needed about the characteristics of the various hydraulic properties of field soils before we can begin to adequately model soil water behavior in wildland situations. Combined use of tensiometers, neutron probes, and thermocouple psychrometers to investigate soil water phenomena *in situ* is highly recommended.

As this study pointed out the importance of snow to the soil water balance of a shortgrass prairie site, perhaps more work on prairie snow

hydrology is needed in this country. This may be a critical area of study as more and more grassland areas are planned for surface mining activity.

Conclusions and Significance of Study

The large amount of unexplained variance found in statistically analyzing the soil water balance was disappointing. The sources of this unexplained variability include the effects of local vegetation height differences, peculiar patterns of mesotopography, local differences in the amount and type of litter and standing vegetation, and variable patterns of microtopography and rill systems. Considerable more variance was explained in testing the evapotranspiration models than was explained in testing the soil water recharge models. This results from an obvious characteristic of the hydrologic cycle. Hydrologic variables become less stochastic and more deterministic as one moves from the input to the output end of the hydrologic cycle.

The results of this study hopefully will add to existing knowledge on prairie hydrology. As man encroaches further and further upon the wildland domain, more information is needed so that management practices can effectively keep the ecosystem in balance. Large portions of our grassland areas are destined for mining activity. Sensible and effective rehabilitation measures can restore disturbed grassland areas to their original state. The results of this study suggest that revegetating disturbed prairie areas can be done in such a way as to increase the snow retention capacity of these sites. Reshaping of topography could also be achieved in such a way as to enhance the soil water balance over that of the original site.

LITERATURE CITED

- Alizai, H. A. and L. C. Hulbert. 1970. Effects of soil texture on evaporative loss and available water in semi-arid climates. *Soil Science* 110:328-332.
- Baderacco, R. J. 1971. An interpretive resource analysis of Pawnee Buttes, Colorado. Ph.D. Diss., Colorado State University, Fort Collins, 341 p.
- Bahrani, B. and S. A. Taylor. 1961. Influence of soil moisture potential and evaporative demand on the actual evapotranspiration from an alfalfa field. *Agron. Jour.* 53:233-237.
- Bertolin, G. and J. Rasmussen. 1969. Preliminary report on the study of the precipitation on the Pawnee National Grasslands. U.S.I.B.P. Grasslands Biome Technical Report No. 17. 38 p.
- Branson, F. A., R. F. Miller, and I. S. McQueen. 1965. Plant Communities and soil moisture relationships near Denver, Colorado. *Ecology* 46:311-319.
- Branson, F. A., R. F. Miller, and I. S. McQueen. 1970. Plant Communities and associated soil and water factors on shale-derived soils in northeastern Montana. *Ecology* 51:391-407.
- Brown, R. W. 1970. Measurement of water potential with thermocouple psychrometers: construction and applications. U.S.D.A. Forest Service Research Paper INT-80. 27 p.
- Brown, R. W. and B. P. Van Haveren [eds.], 1972. Psychrometry in Water Relations Research. Utah Agricultural Experiment Station, Logan, Utah. 342 pages.
- Bruce, R. R. 1972. Hydraulic conductivity evaluation of the soil profile from soil water retention relations. *Soil Sci. Soc. Amer. Proc.* 36:555-561.
- Cable, D. R. 1969. Competition in the semidesert grass-shrub type as influenced by root systems, growth habits, and soil moisture extraction. *Ecology* 50:27-38.
- Cowan, I. R. 1965. Transport of water in the soil-plant-atmosphere system. *Jour. Appl. Ecol.* 2:221-239.
- Dahl, B. E. 1963. Soil moisture as a predictive index to forage yield for the sandhills range type. *Jour. Range Mgmt.* 16:128-132.
- Day, P. R. 1965. Particle fractionation and particle-size analysis. *In* Methods of Soil Analysis, Part I, pp. 545-567. American Society of Agronomy, ASA Monograph No. 9, Madison, Wisconsin.

- Dickinson, C. E. and C. V. Banker. 1972. Pawnee Site field plant list. U.S.I.B.P. Grasslands Biome Technical Report No. 139. 44 p.
- Dort, W., Jr. 1959. Geomorphology of the southern Great Plains in relation to livestock production. *Jour. Range Mgmt.* 12:292-296.
- Douglass, J. E. 1966. Volumetric calibration of neutron moisture probes. *Soil Sci. Soc. Amer. Proc.* 30:541-544.
- Dove, L. D. and W. R. Bottoms. 1969. Measurement of plant water potential with a thermopile psychrometer. *Z. Pflanzenphysiol* 61:165-167.
- Duley, F. L. and L. L. Kelly. 1939. Effect of soil type, slope, and surface conditions on intake of water. *Nebraska Agric. Exp. Sta. Research Bulletin* No. 112. 16 p.
- Franklin, W. T. 1969. Mineralogy of representative soils at the Pawnee Site. U.S.I.B.P. Grasslands Biome Technical Report No. 30. 12 p.
- Froehlich, H. A. 1969. Forest snow accumulation factors in the Colorado Front Range. Ph.D. Diss., Colorado State University, Fort Collins. 103 p.
- Galbraith, A. F. 1969. Soil water study of a shortgrass prairie ecosystem. U.S.I.B.P. Grasslands Biome Technical Report No. 6. 53 p.
- Galbraith, A. F. 1971. The soil water regime of a shortgrass prairie ecosystem. Ph.D. Dissertation, Colorado State University, Fort Collins. 127 p.
- Gardner, W. R. and C. F. Ehlig. 1963. The influence of soil water on transpiration by plants. *Jour. Geophys. Res.* 68:5719-5724.
- Gates, D. M. and R. J. Hanks. 1967. Plant factors affecting evapotranspiration. In *Irrigation of Agricultural Lands*, pp. 506-533, R. M. Hagan, H. R. Haise, and T. W. Edminster [eds.], ASA Monograph No. 11, American Society of Agronomy, Madison, Wisconsin.
- Gray, D. M. 1970. Snow hydrology of the prairie environment. In *Snow Hydrology, Proceedings of a Workshop Seminar*, pp. 21-31. IHD, Canadian National Committee.
- Gray, D. M., D. I. Norum, and J. M. Murray. 1969. Infiltration characteristics of prairie soils. Paper presented at the Annual Meeting, American Society of Range Management, Feb. 10-13, 1969, Calgary, Alberta, Canada. 23 p.
- Greb, B. W. and A. L. Black. 1971. Vegetative barriers and artificial fences for managing snow in the central and northern plains. In *Proceedings, Snow and Ice in Relation to Wildlife and Recreation Symposium*, pp. 96-111, Iowa State University, Ames.

- Haupt, H. F. 1967. Infiltration, overland flow, and soil movement on frozen and snow-covered plots. *Water Resources Research* 3:145-161.
- Hill, A. V. 1930. A thermal method of measuring the vapour pressure of an aqueous solution. *Proc. Royal Soc. London, Series A* 127: 9-19.
- Hillel, D. 1971. *Soil water: physical principles and processes*. Academic Press, New York. 288p.
- Horton, M. L., L. N. Namken, and J. T. Ritchie. 1970. Role of plant canopies in evapotranspiration. *In* *Evapotranspiration in the Great Plains*, pp. 301-338. Research Committee, Great Plains Agricultural Council Publication No. 50, Agricultural Experiment Station, Kansas State University, Manhattan.
- Hsieh, J. J. C. and F. P. Hungate. 1970. Temperature compensated Peltier psychrometer for measuring plant and soil water potentials. *Soil Science* 110:252-257.
- Hutchison, B. A. 1965. Snow accumulation and disappearance influenced by big sagebrush. *USDA Forest Service Research Note RM-46*. 7 p.
- Jameson, D. A. 1969. General description of the Pawnee Site. *U.S.I.B.P. Grasslands Biome Technical Report No. 1*. 32 p.
- Knight, D. H. 1971. Some measurements of vegetation structure on the Pawnee Grassland, 1970. *U.S.I.B.P. Grasslands Biome Technical Report No. 72*. 42 p.
- Knight, D. H. 1972. Leaf area dynamics on the Pawnee Grassland, 1970-1971. *U.S.I.B.P. Grasslands Biome Technical Report No. 164*, 22 p.
- Kramer, P. J. 1969. *Plant and soil water relationships: a modern synthesis*. McGraw-Hill Book Co., New York. 482 p.
- Martinelli, M. 1966. Possibilities of snowpack management in alpine areas. *In* *Forest Hydrology*, pp. 225-231, Sopper and Lull [eds.], Pergamon Press, Oxford.
- May, M., R. Lang, L. Lujan, P. Jacoby, and W. Thompson. 1971. Reclamation of strip mine spoil banks in Wyoming. *Wyoming Agric. Exp. Sta. Research Journal No. 51*. 32 p.
- McKay, G. A. 1970. Problems of measuring and evaluating snowcover. *In* *Snow Hydrology, Proceedings of a Workshop Seminar*, pp. 49-62. IHD, Canadian National Committee.
- McQueen, I. S. and R. F. Miller. 1968. Calibration and evaluation of a wide range gravimetric method for measuring moisture stress. *Soil Science* 106:225-231.

- Meyn, R. L. and R. S. White. 1972. Calibration of thermocouple psychrometers: a suggested procedure for development of a reliable predictive model. *In* Psychrometry in Water Relations Research, pp. 56-64, R. W. Brown, and B. P. Van Haveren [eds.] Utah Agricultural Experiment Station, Logan, Utah.
- Nash, A. J. 1963. A method for evaluating the effects of topography on the soil water balance. *Forest Science* 9:413-422.
- Neumann, H. H. and G. W. Thurtell. 1972. A Peltier-cooled dewpoint thermocouple hygrometer for *in situ* measurement of water potentials. *In* Psychrometry in Water Relations Research, R. W. Brown and B. P. Van Haveren [eds.], pp. 103-112, Utah Agricultural Experiment Station, Logan, Utah.
- Oster, J. D., S. L. Rawlins, and R. D. Ingvalson. 1969. Independent measurement of matric and osmotic potential of soil water. *Soil Science Soc. Amer. Proc.* 33:188-192.
- Owen, P. C. 1952. The relation of germination of wheat to water potential. *Jour. Exptl. Bot.* 3:188-203.
- Papendick, R. I., V. L. Cochran, and W. M. Woody. 1971. Soil water potential and water content profiles with wheat under low spring and summer rainfall. *Agron. Jour.* 63:731-734.
- Peck, A. J. 1968. Theory of the Spanner psychrometer, 1. The thermocouple. *Agri. Meteorol.* 5:433-447.
- Peck, A. J. 1969. Theory of the Spanner psychrometer, 2. Sample effects and equilibration. *Agri. Meteorol.* 6:111-124.
- Philip, J. R. 1964. The gain, transfer, and loss of soil-water. *In* Water Resources Use and Management, pp. 257-275, E. S. Hills [eds.], Melbourne Univ. Press, Melbourne, Australia.
- Philip, J. R. 1966. Plant water relations: some physical aspects. *Ann. Rev. Plant Phys.* 17:245-268.
- Philip, J. R. 1969. The soil-plant-atmosphere continuum in the hydrological cycle. *Hydrological Forecasting, Tech. Note. No. 92, WMO-No. 228. TP. 122. 11 p.*
- Rasmussen, J. L., G. Bertolin, and G. F. Almeyda. 1971. Grassland climatology of the Pawnee Grassland. U.S.I.B.P. Grasslands Biome Technical Report No. 127. 79 p.
- Rauzi, F. and W. W. Zingg. 1956. Rainmaker helps prove a theory. *Soil Conserv.* 21:228-229.
- Rauzi, F., C. L. Fly, and E. J. Dyksterhuis. 1968. Water intake on midcontinental rangelands as influenced by soil and plant cover. *USDA Technical Bulletin No. 1390. 58 p.*

- Rauzi, F. and F. M. Smith. 1973. Infiltration rates by three soils with three grazing levels at the Central Plains Experimental Range. *Journal of Range Mgmt.*, in press.
- Rawlins, S. L. 1966. Theory for thermocouple psychrometers used to measure water potential in soil and plant samples. *Agri. Meteorol.* 3:293-310.
- Rawlins, S. L. and F. N. Dalton. 1967. Psychrometric measurement of soil water potential without precise temperature control. *Soil Sci. Soc. Amer., Proc.* 31:297-301.
- Richards, L. A. 1965. Physical condition of water in soil. *In Methods of Soil Analysis, Part I*, pp. 128-152. American Society of Agronomy, ASA Monograph No. 9, Madison, Wisconsin.
- Richards, L. A. and G. Ogata. 1958. Thermocouple for vapor pressure measurement in biological and soil systems at high humidity. *Science* 128:1089-1090.
- Richards, L. A. and G. Ogata. 1961. Psychrometric measurements of soil samples equilibrated on pressure membranes. *Soil Sci. Soc. Amer. Proc.* 25:456-459.
- Rogowski, A. S. 1971. Watershed physics: model of the soil moisture characteristic. *Water Resources Res.* 7:1575-1582.
- Sartz, R. S. 1972. Effect of topography on microclimate in southwestern Wisconsin. USDA Forest Service Research Paper NC-74. 6 p.
- Sharp, A. L., J. J. Bond, J. W. Neuberger, A. R. Kuhlman, and J. K. Lewis. 1964. Runoff as affected by intensity of grazing on rangeland. *J. Soil and Water Cons.* 19:103-106.
- Shaver, J. C. and H. G. Fisser. 1972. Detailed vegetation mapping of the IBP Pawnee Site. U.S.I.B.P. Grasslands Biome Technical Report No. 150. 44 p.
- Shown, L. M., G. C. Lusby, and F. A. Branson. 1972. Soil-moisture effects of conversion of sagebrush cover to bunchgrass cover. *Water Resources Bull.* 8:1265-1272.
- Slatyer, R. O. 1967. *Plant-water relationship*. Academic Press, New York. 366 p.
- Slatyer, R. O. and O. T. Denmead. 1964. Water movement through the soil-plant-atmosphere system. *In Proceedings, National Symposium on Water Resources Use and Management*, pp. 276-289, E. S. Hills [ed.]. Melbourne Univ. Press, Melbourne, Australia.
- Smika, D. E. and C. J. Whitfield. 1966. Effect of standing wheat stubble on storage of winter precipitation. *J. Soil and Water Conserv.* 21:138-141.

- Smith, F. M. 1971a. Central basin hydrologic process studies. U.S.I.B.P. Grasslands Biome Technical Report No. 91. 26 p.
- Smith, F. M. 1971b. A volumetric-threshold infiltration model. Ph.D. Dissertation. Colorado State University, Fort Collins, 234 p.
- Smith, F. M. 1971c. Growing season precipitation records, Central Plains Experimental Range, USDA-ARS, Nunn, Colorado. U.S.I.B.P. Grasslands Biome Technical Report No. 74. 73 p.
- Smith, F. M. and W. D. Striffler. 1969. Pawnee Site microwatersheds: selection, description, and instrumentation. U.S.I.B.P. Grasslands Biome Technical Report No. 5. 29 p.
- Spanner, D. C. 1951. The Peltier effect and its use in the measurement of suction pressure. *Jour. Exptl. Bot.* 11:145-168.
- Staple, W. J., J. J. Lehane, and A. Wenhardt. 1960. Conservation of soil moisture from fall and winter precipitation. *Can. J. Soil Sci.* 40:80-88.
- Stoekeler, J. H. and W. R. Curtis. 1960. Soil moisture regime in southwestern Wisconsin as affected by aspect and forest type. *Jour. of Forestry* 58:892-896.
- Striffler, W. D. 1969. The grassland hydrologic cycle. In *The Grassland Ecosystem--A Preliminary Synthesis*, pp. 101-116, R. L. Dix and R. G. Beidleman [eds.]. Range Sci. Dept. Science Series No. 2. Colorado State University.
- Striffler, W. D. 1971. Hydrologic data, 1970, Pawnee Grasslands. U.S.I.B.P. Grasslands Biome Technical Report No. 75. 23 p.
- Striffler, W. D. 1972. Hydrologic data at Pawnee Site, 1971. U.S.I.B.P. Grasslands Biome Technical Report No. 196. 67 p.
- Taylor, S. A. 1952. Estimating the integrated soil moisture tension in the root zone of growing crops. *Soil Science* 73:331-339.
- Taylor, S. A. 1964. Water condition and flow in the soil-plant-atmosphere system. In *Forage Plant Physiology and Soil-range Relationships*, pp. 81-107, American Society of Agronomy, ASA Special Publication No. 5.
- Taylor, S. A. 1965. Measuring soil-water potential. In *Methodology of Plant Eco-physiology*, Proceedings of the Montpellier Symposium UNESCO, 1965, pp. 149-157.
- Tomanek, G. W. 1959. Effects of climate and grazing on mixed prairie. In Grasslands, pp. 371-377, Amer. Assoc. Adv. Sci. Publ. No. 53.

- Van Haveren, B. P. and A. F. Galbraith. 1971. Some hydrologic and physical properties of the major soil types on the Pawnee Intensive Site. U.S.I.B.P. Grasslands Biome Technical Report No. 115. 46 p.
- Wiebe, H. H., G. S. Campbell, W. H. Gardner, S. L. Rawlins, J. W. Cary, and R. W. Brown. 1971. Measurement of plant and soil water status. Utah Agric. Exp. Stn. Bull. No. 484. 71 p.
- Wiegand, C. L. and S. A. Taylor. 1961. Evaporative drying of porous media. Utah Agric. Exp. Stn. Special Report No. 15. 28 p.
- Willis, W. O., H. J. Haas, and C. W. Carlson. 1969. Snowpack runoff as affected by stubble height. Soil Science 107:256-259.
- Willis, W. O. and H. J. Haas. 1971. Snow and snowmelt management with level benches, small grain stubble, and windbreaks. In Proc., Snow and Ice in Relation to Wildlife and Recreation Symposium, pp. 86-95, Iowa State University, Ames.
- Wolff, D. N. 1970. Grassland infiltration phenomena. U.S.I.B.P. Grasslands Biome Technical Report No. 54. 125 p.
- Yevjevich, V. 1972. Probability and statistics in hydrology. Water Resources Publications, Fort Collins, Colorado. 302 p.

APPENDIX A
TOPOGRAPHIC PROFILES OF
SAMPLING TRANSECTS

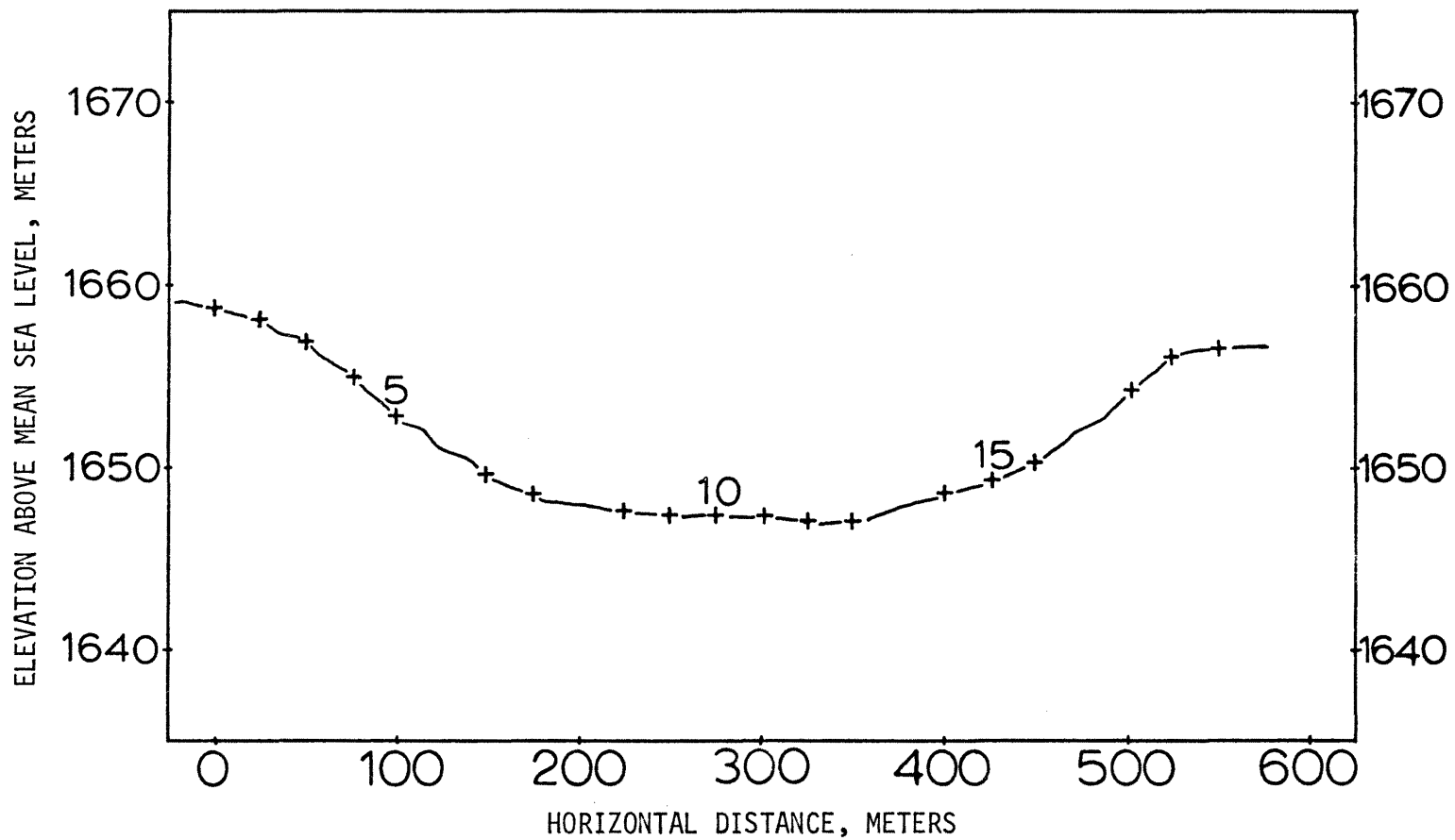

Figure A1. Topographic profile of the lightly-grazed transect, showing the 19 sampling points.

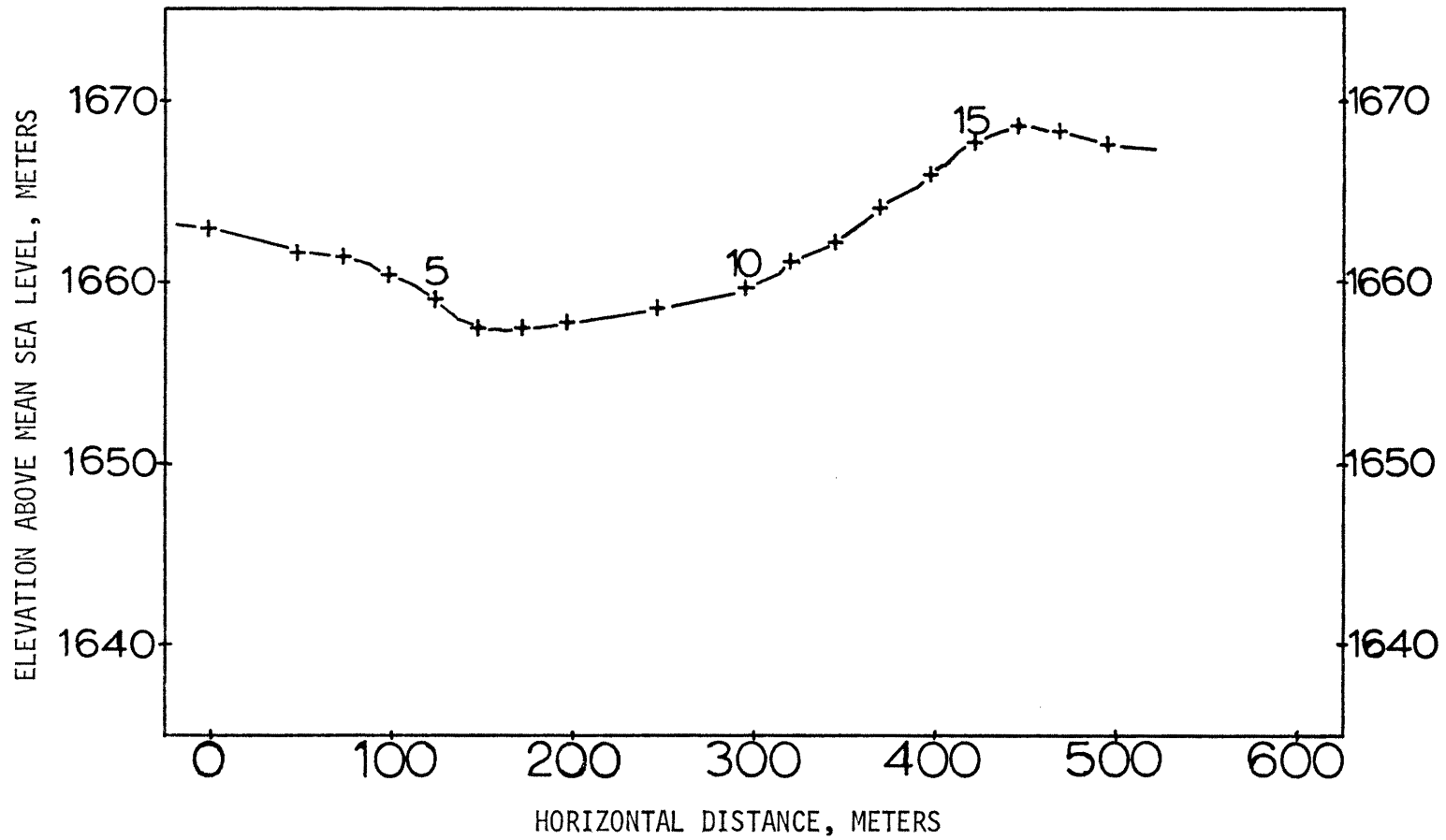

Figure A2. Topographic profile of the moderately-grazed transect, showing the 18 sampling points.

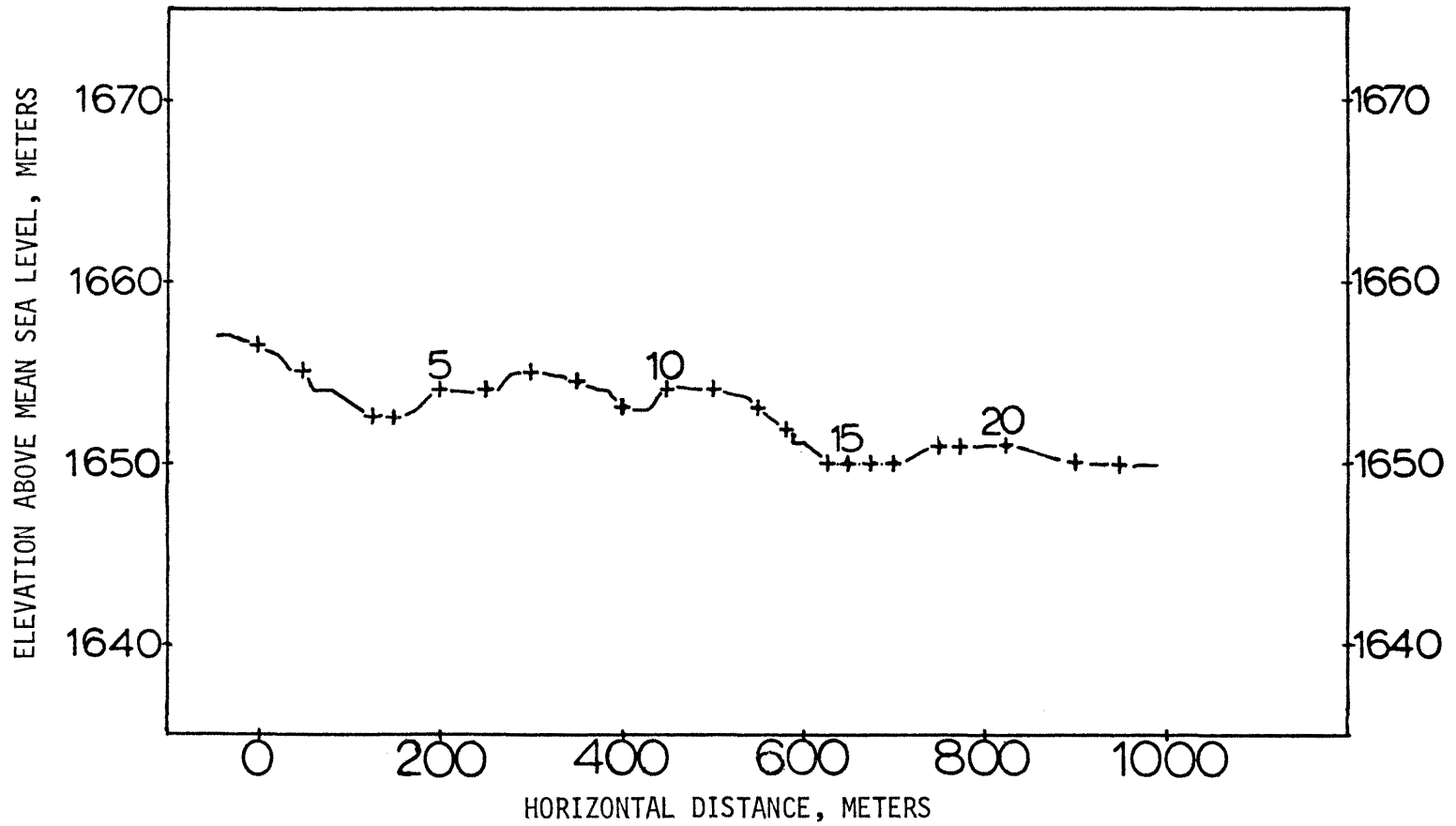

Figure A3. Topographic profile of the heavily-grazed transect, showing the 22 sampling points.

APPENDIX B

SUMMARIES OF SOIL WATER
CONTENT AND SOIL WATER
POTENTIAL DATA

AVERAGE SOIL WATER CONTENTS BY GRAZING
TREATMENT OVER TIME

Date	Grazing Treatment		
	Light (cm of water per 150 cm of soil)	Moderate	Heavy
8/5/70	24.4	22.3	33.4
8/11/70	22.1	21.1	32.9
9/3/70	19.2	18.6	30.5
12/12/70	22.7	21.0	30.3
1/29/71	23.2	23.0	32.7
3/24/71	24.0	23.1	33.7
4/18/71	23.2	22.9	32.6
5/6/71	26.9	27.1	37.1
6/4/71	26.9	26.8	35.9
6/24/71	23.4	22.6	32.1
7/4/71	21.7	21.7	30.4
7/16/71	20.4	19.4	29.4
7/24/71	20.2	19.3	28.5
7/28/71	19.8	19.2	28.0
8/6/71	18.9	18.6	27.4
8/9/71	18.9	18.5	26.9
8/16/71	18.4	18.2	26.6
8/23/71	18.7	17.9	26.7
9/10/71	20.2	17.4	27.0

AVERAGE SOIL WATER CONTENTS BY SOIL
TYPE OVER TIME

Date	Soil Type					
	47	51	55	66	87b	87z
(cm of water per 150 cm of soil)						
8/5/70	26.8	19.3	23.8	26.5	26.7	34.2
8/11/70	27.3	18.3	23.2	24.1	24.8	32.8
9/3/70	24.0	16.9	19.9	20.3	23.4	31.1
12/12/70	26.1	17.3	21.4	24.0	25.5	31.8
1/29/71	27.3	18.6	23.2	25.5	28.2	33.8
3/24/71	27.8	19.8	23.6	25.9	28.4	34.4
4/18/71	27.1	18.7	22.8	25.2	28.2	33.8
5/6/71	30.6	23.7	28.0	28.8	32.0	37.9
6/4/71	30.3	21.8	27.1	28.8	31.7	37.6
6/24/71	26.5	18.0	23.3	25.2	26.6	33.8
7/4/71	25.6	16.6	21.7	23.4	26.5	31.9
7/16/71	24.0	16.1	20.1	22.0	24.0	30.5
7/24/71	23.8	15.1	19.7	21.7	23.9	29.8
7/28/71	23.5	14.8	19.4	21.4	23.8	29.3
8/6/71	22.9	13.8	18.8	20.4	23.8	28.7
8/9/71	22.7	13.7	18.6	20.4	23.5	28.2
8/16/71	22.3	13.3	18.2	20.0	23.2	27.8
8/23/71	22.5	13.2	18.2	20.1	22.6	28.0
9/10/71	20.1	15.1	19.4	20.8	21.0	29.7

SOIL WATER CONTENTS BY POSITION ON
SLOPE OVER TIME

Date	Position on Slope				Bottom
	Top	Upper 1/3	Middle 1/3	Lower 1/3	
(cm water in 150 cm soil)					
8/5/70	23.1	28.8	28.8	24.5	27.5
8/11/70	22.9	27.8	26.3	26.7	27.0
9/3/70	20.6	25.2	21.7	19.3	24.9
12/12/70	21.9	27.5	23.9	22.4	26.2
1/29/71	23.4	28.7	27.0	23.8	28.0
3/24/71	23.9	28.9	28.3	24.4	28.6
4/18/71	23.0	28.7	27.3	23.7	27.7
5/6/71	28.0	32.5	31.5	27.9	31.8
6/4/71	27.5	32.8	30.8	27.2	30.9
6/24/71	23.3	29.2	26.9	23.4	27.0
7/4/71	22.6	27.2	25.4	21.6	25.9
7/16/71	20.9	25.9	23.8	19.6	24.7
7/24/71	20.7	25.5	23.2	19.4	24.2
7/28/71	20.5	25.1	22.8	19.0	23.8
8/6/71	20.2	24.4	22.1	18.2	23.2
8/9/71	19.8	24.3	21.8	18.2	23.0
8/16/71	19.4	23.8	21.5	17.7	22.7
8/23/71	19.3	23.9	21.5	17.7	22.8
9/10/71	19.7	25.1	22.9	18.3	24.3

SOIL WATER POTENTIALS BY
DEPTH AND SAMPLING DATE FOR THE
ASCALON SANDY LOAM SITE (TUBE #3)

Date	Soil Water Potentials				
	2	10	20 (bars)	40	60
5/8/71	-0.8	-1.4	-1.1	-1.4	<-70
5/18/71	-0.8	-0.8	-0.8	-0.8	<-70
6/5/71	-5.6	-2.7	-0.8	-0.8	-47.6
6/10/71	-41.0	-7.4	-1.0	-0.8	-46.1
6/15/71	-2.4	-9.3	-4.4	-0.8	-45.0
6/16/71	-4.2	-13.7	-3.9	-0.8	-45.0
6/21/71	-53.2	-24.6	-10.4	-2.6	-40.7
6/24/71	-22.1	-29.5	-20.5	-5.9	-38.5
7/1/71	-49.6	-49.8	-44.2	-19.3	-38.2
7/8/71	-72.6	-70.3	-60.2	-41.1	-44.3
7/15/71	-72.6	-65.1	-61.7	-59.2	-56.9
7/22/71	-79.6	-75.5	-70.3	-66.8	-68.0
7/29/71	-87.3	-80.8	-75.5	-72.1	-73.2
8/5/71	-45.7	-51.9	-59.9	-67.4	-69.2
8/12/71	-58.8	-64.0	-62.8	-63.4	-66.8

SOIL WATER POTENTIALS BY
DEPTH AND SAMPLING DATE FOR THE
UNDIFFERENTIATED SOIL SITE (TUBE #7)

Date	<u>Soil Water Potentials</u>				
	2	10	<u>Depth (cm)</u> 20 (bars)	40	60
5/8/71	-1.0	-0.8	-0.8	-0.8	-6.3
5/18/71	-2.1	-0.8	-0.8	-0.8	-6.1
6/5/71	-14.7	-8.3	-0.8	-0.8	-4.4
6/10/71	-19.8	-12.2	-5.9	-2.7	-2.2
6/15/71	-29.4	-17.3	-12.7	-9.4	-6.2
6/16/71	-21.5	-16.5	-10.6	-6.9	-5.7
6/21/71	-48.0	-32.1	-21.3	-20.3	-11.7
6/24/71	-29.6	-41.0	-30.6	-32.5	-24.4
7/1/71	-54.2	-54.6	-40.1	-42.8	-37.1
7/8/71	-68.6	-70.3	-51.6	-48.3	-43.7
7/15/71	-68.6	-65.1	-55.4	-51.3	-46.9
7/22/71	-76.1	-75.0	-72.1	-56.6	-51.6
7/29/71	-84.9	-80.8	-75.5	-57.8	-55.5
8/5/71	-3.7	-33.2	-47.0	-46.7	-47.3
8/12/71	-63.4	-55.9	-50.3	-51.2	-50.0

SOIL WATER POTENTIALS BY
DEPTH AND SAMPLING DATE FOR THE
RENOHILL SANDY LOAM SITE (TUBE #11)

Date	Soil Water Potentials				
	2	10	Depth (cm) 20 (bars)	40	60
5/8/71	-1.3	-1.9	-0.8	-0.8	<-70
5/18/71	-0.8	-1.1	-0.8	-0.8	<-70
6/5/71	-8.7	-1.6	-0.8	-0.8	-12.2
6/10/71	-38.9	-7.2	-3.3	-0.8	- 6.2
6/15/71	-27.5	-17.6	-7.2	-0.8	- 4.7
6/16/71	-20.5	-14.9	-6.5	-0.8	- 4.7
6/21/71	-45.1	-30.7	-21.0	-0.8	- 3.4
6/24/71	----	-38.4	-36.5	-2.1	- 4.9
7/1/71	-58.2	-57.0	-53.2	-12.6	- 4.6
7/8/71	-64.0	-69.2	-67.4	-32.0	- 9.2
7/15/71	-61.1	-65.1	-61.7	-49.5	-22.0
7/22/71	-70.9	-75.0	-69.7	-66.8	-34.4
7/29/71	-84.3	-79.6	-73.8	-70.9	-42.4
8/5/71	-53.1	-54.2	-59.9	-66.3	-50.5
8/12/71	-54.8	-64.0	-63.4	-64.0	-58.6

SOIL WATER POTENTIALS BY
DEPTH AND SAMPLING DATE FOR THE
SHINGLE LOAM SITE (TUBE #16)

Date	Soil Water Potentials				
	2	10	<u>Depth (cm)</u> 20 (bars)	40	60
5/8/71	-1.0	-1.6	-1.4	-0.8	-28.0
5/18/71	-0.8	-1.3	-0.8	-0.8	- 1.7
6/5/71	-18.3	-3.0	-0.8	-0.8	- 0.8
6/10/71	-51.5	-6.8	-3.3	-0.8	- 0.8
6/15/71	-0.8	-11.4	-8.4	-0.8	- 0.8
6/16/71	-0.8	-12.2	-3.9	-1.5	- 2.1
6/21/71	-40.4	-20.1	-10.3	-0.8	- 0.8
6/24/71	-19.3	-27.0	-18.9	-3.6	- 2.8
7/1/71	-59.9	-39.8	-31.8	-9.9	- 3.4
7/8/71	-62.2	-61.4	-39.6	-14.7	- 4.0
7/15/71	-54.2	-62.8	-47.9	-19.0	- 6.9
7/22/71	-65.1	-73.2	-59.2	-29.2	-12.1
7/29/71	-83.7	----	-75.0	-36.1	-17.0
8/5/71	-1.1	-18.6	-47.5	-35.1	-17.0
8/12/71	-44.5	-49.2	-51.1	-35.5	-22.1

APPENDIX C

SUMMARIES OF MULTIPLE
REGRESSION ANALYSES

REGRESSION ANOVA FOR SNOWMELT RECHARGE

<u>Source</u>	<u>df</u>	<u>SS</u>	<u>MS</u>	<u>F</u>
Regression	5	114.21	22.84	**5.51
Residual	54	223.97	4.15	
Total	59	338.17		

**Significant at 0.99 level

N = 60

$R^2 = 0.338$

Std. Err. of Est. = 2.04

REGRESSION EQUATION FOR SNOWMELT RECHARGE

$$\hat{Y} \text{ (cm of water)} = 5.13751 - 0.07426 X_7 + 0.03204 X_9 + 0.25327 X_{22} \\ + 0.03034 X_{36} - 0.09673 X_{38}$$

REGRESSION ANOVA FOR RAIN RECHARGE

<u>Source</u>	<u>df</u>	<u>SS</u>	<u>MS</u>	<u>F</u>
Regression	6	34.22	5.70	**4.84
Residual	53	62.46	1.18	
Total	59	96.68		

**Significant at 0.99 level

N = 60

$R^2 = 0.323$

Std. Err. of Est. = 1.09

REGRESSION EQUATION FOR RAIN RECHARGE

$$\hat{Y} \text{ (cm of water)} = 6.40919 - 0.00641 X_5 + 0.02707 X_9 + 0.17103 X_{11} \\ - 2.24695 X_{14} + 0.25088 X_{31} + 26.11029 X_{44}$$

REGRESSION ANOVA FOR TOTAL RECHARGE

(3 variables)

<u>Source</u>	<u>df</u>	<u>SS</u>	<u>MS</u>	<u>F</u>
Regression	3	90.71	30.24	**5.90
Residual	56	287.05	5.13	
Total	59	377.76		

**Significant at 0.99 level

N = 60

 $R^2 = 0.240$

Std. Err. of Est. = 2.26

Regression Coefficients

constant = 3.71276

 $X_9 = 0.03878$ $X_{22} = 0.13405$ $X_{41} = 0.12304$

(10 variables)

<u>Source</u>	<u>df</u>	<u>SS</u>	<u>MS</u>	<u>F</u>
Regression	10	143.75	14.37	**3.01
Residual	49	234.01	4.78	
Total	59	377.76		

**Significant at 0.99 level

N = 60

 $R^2 = 0.381$

Std. Err. of Est. = 2.19

Regression Coefficients

constant = 0.38668

 $X_8 = -0.02140$ $X_9 = 0.04967$ $X_{13} = 1.45884$ $X_{22} = 0.07070$ $X_{31} = 0.70217$ $X_{33} = 0.59845$ $X_{35} = -0.30786$ $X_{36} = 0.06745$ $X_{41} = 0.16747$ $X_{42} = -0.00130$

REGRESSION ANOVA FOR TOTAL DEPLETION

<u>Source</u>	<u>df</u>	<u>SS</u>	<u>MS</u>	<u>F</u>
Regression	4	115.29	28.82	**22.93
Residual	55	69.15	1.26	
Total	59	184.44		

**Significant at 0.99 level

N = 60

$R^2 = 0.625$

Std. Err. of Est. = 1.12

REGRESSION EQUATION FOR TOTAL DEPLETION

$$\hat{Y} \text{ (cm of water)} = 12.54227 + 0.44781 X_3 - 0.00852 X_5 + 0.24934 X_{27} \\ + 0.04514 X_{45}$$

REGRESSION ANOVA FOR EARLY DEPLETION

<u>Source</u>	<u>df</u>	<u>SS</u>	<u>MS</u>	<u>F</u>
Regression	7	134.89	19.27	**14.46
Residual	52	69.28	1.33	
Total	59	204.17		

**Significant at 0.99 level

N = 60

$R^2 = 0.661$

Std. Err. of Est. = 1.15

REGRESSION EQUATION FOR EARLY DEPLETION

$$\hat{Y} \text{ (cm of water)} = 3.95127 + 0.38621 X_2 + 0.39310 X_3 - 0.01264 X_5 \\ + 0.03023 X_8 + 0.75606 X_{28} - 93.92011 X_{39} \\ + 0.07827 X_{45}$$

REGRESSION ANOVA FOR LATE DEPLETION

<u>Source</u>	<u>df</u>	<u>SS</u>	<u>MS</u>	<u>F</u>
Regression	5	66.04	13.21	**13.70
Residual	54	52.07	0.96	
Total	59	118.11		

**Significant at 0.99 level

N = 60

$R^2 = 0.559$

Std. Err. of Est. = 0.98

REGRESSION EQUATION FOR LATE DEPLETION

$$\hat{Y} \text{ (cm of water)} = 7.63608 + 0.28333 X_3 + 0.01461 X_7 - 0.01619 X_9 \\ - 0.54685 X_{19} + 75.42296 X_{40}$$

REGRESSION ANOVA FOR RECHARGE RATIO

<u>Source</u>	<u>df</u>	<u>SS</u>	<u>MS</u>	<u>F</u>
Regression	5	0.6122	0.1225	**7.71
Residual	54	0.8581	0.0159	
Total	59	1.4703		

**Significant at 0.99 level

N = 60

$R^2 = 0.416$

Std. Err. of Est. = 0.126

REGRESSION EQUATION FOR RECHARGE RATIO

$$\hat{Y} = 0.63399 - 0.00470 X_7 - 0.00072 X_8 - 0.00742 X_{21} \\ + 0.01009 X_{22} + 0.00950 X_{35}$$

APPENDIX D

CONFIDE: A FORTRAN IV
COMPUTER PROGRAM FOR
CONFIDENCE INTERVAL
CALCULATION

```

PROGRAM          CONFIDE                                CDC 6400 FTN V3.0-P308 OPT=1 05/03/73

      PROGRAM CONFIDE
      1(INPUT,OUTPUT,TAPF5=INPUT,TAPF6=OUTPUT)
C
C***PROGRAM TO CALCULATE CONFIDENCE INTERVALS FOR E(Y) FOR GIVEN VECTORS V.
5 C      (V CONTAINS VALUES OF THE INDEPENDENT VARIABLES)
C
C
C***ORIGINAL PROGRAM (CI) WRITTEN BY T. COPENHAVER, COLORADO STATE UNIVERSITY
C      STATISTICAL LABORATORY, DECEMBER 10, 1970.
10 C***MODIFIED BY B. P. VAN HAVEREN, NATURAL RESOURCE ECOLOGY LAB.
C      MAY 22, 1972.
C
C***REFERENCE---GRAYBILL, F. A. 1961. AN INTRODUCTION TO LINEAR STATISTICAL
C      MODELS. VOLUME I. MCGRAW-HILL. 463 P. (SEE PP. 121,164)
15 C
C
C*****DATA CARD SETUP*****
C
C***CARD 1 (PROBLEM IDENTIFICATION)
20 C
C***COLUMNS 1-40 MAY CONTAIN ANYTHING
C
C***CARD 2 (PARAMETERS)
C
25 C***COLS 1-5   NCI (NO. OF CONFIDENCE INTERVALS TO BE COMPUTED)
C      6-10   N   (NO. OF OBSERVATIONS (CASES))
C      11-15  P   (NO. OF INDEPENDENT VARIABLES AFTER TRANSGENERATION)
C      16-20  OPTION=(1) IF Z-PRIME-Z (ZTZ) INVERSE FROM STAT38F IS
30 C              READ IN
C              OPTION=(2) IF DATA ARE READ IN
C      21-30  SIGMA SQUARED (RESIDUAL MEAN SQUARE FROM REGRESSION AOV)
C      31-40  ALPHA (SIZE OF TEST FOR 100(1-ALPHA) PER CENT C.I.
C      41-50  T    (T VALUE, I.E., LOOK UP A (1 - ALPHA/2) VALUE
C              WITH (N-1) DEGREES OF FREEDOM)
35 C
C***CARD 3 VARIABLE FORMAT (FOR READING DATA OR ZTZ INVERSE)
C
C***COLUMNS 1-40 MUST CONTAIN P FIELDS USING F-TYPE FORMAT CODES.
40 C
C***CARD 4 (COEFFICIENT ESTIMATES OF REGRESSION EQUATION)
C
C***COLS 1-10  BETA(1) (CONSTANT ESTIMATE)
C      11-20  BETA(2) (COEFFICIENT ESTIMATE FOR VARIABLE 1)
C      ETC.
45 C
C***STEP(5) MEANS OF INDEPENDENT VARIABLES (**USE ONLY WITH OPTION 1**)
C
COLUMNS 1-10 MEAN OF INDEPENDENT VARIABLE 1
C      11-20 MEAN OF INDEPENDENT VARIABLE 2
50 C      ETC.
C
C***STEP 6
C
C      (1) IF OPTION=1, READ IN ZTZ INVERSE (CONTAINS P ROWS, P COLUMNS)
55 C

```

```

PROGRAM      CONFIDE

C***CAUTION*****ZTZ INVERSE (CORRECTED SS AND X-PRODUCTS MATRIX) IS
C              SAME AS XTX INVERSE GIVEN AS OPTIONAL OUTPUT IN
C              STAT3HW. HOWEVER, THIS MATRIX HAS ELEMENTS WITH ONLY
C              FIVE (5) DIGITS BEHIND DECIMAL, WHERE THE VALUES FOR
60  C          THE ELEMENTS OF THE XTX INVERSE IN STAT3HW ARE CLOSE
C          TO ZERO (E.G. BETWEEN -0.0001 AND +0.0001). THE CO-
C          VARIANCE MATRIX MUST BE USED FOR COMPUTING THE ZTZ
C          INVERSE. IF THE ELEMENTS DUE TO THE DEPENDENT VARI-
65  C          ABLE ARE REMOVED FROM THE COVARIANCE MATRIX, THE RE-
C          SULTING P X P MATRIX IS THE SAME AS THE ZTZ/(N-1)
C          MATRIX. MULTIPLY EACH ELEMENT BY (N-1) AND INVERT THE
C          RESULTING MATRIX. EIGHT SIGNIFICANT DIGITS BEHIND THE
C          DECIMAL ARE RECOMMENDED.
C
70  C          (2) IF OPTION=2, READ IN DATA.          (CONTAINS N ROWS, P COLUMNS)
C
C***EACH ROW MUST BEGIN ON NEW CARD
C
75  C***STEP 7 (READ IN VECTOR V FOR EACH C.I.)
C
C          COLUMNS 1-10 VALUE OF VARIABLE 1 FOR 1ST C.I.
C          11-20 VALUE OF VARIABLE 2 FOR 1ST C.I.
C          ETC.
80  C
C***REPEAT STEP 7 FOR AS MANY CONF. INTERVALS AS REQUESTED IN STEP 1.
C
C
85  C*****
C*****
C*****
C*****
C
90  C
C
C
C
95  C          DIMENSION BETA(16),V(16),MEAN(16),VV(16),VVV(16),B(16,16),ID(10),
C          1 X(16,16),Z(16,16),DATA(16),FMT(10)
C          INTEGER P,OPTION
C          REAL MEAN
C          READ 50,1D
100  C          50 FORMAT(10AH)
C          READ 1,(NCI,N,P,OPTION,SIGMA,ALPHA,T
C          1 FORMAT(4I5,3F10,0)
C          READ 50,FMT
C          IP=P + 1
C          READ 2,(BETA(I),I=1,IP)
105  C          2 FORMAT(8F10,0)
C          IF(OPTION.EQ.2) GO TO 5
C
C
C***OPTION 1
C
110  C          READ 2,(MEAN(I),I=2,IP)

```

```

PROGRAM      CONFIDF
              DO 3 I=2,IP
              3 READ (5,FMT) (Z(I,J),J=2,IP)
C
C***EACH ELEMENT OF Z(I,J) SHOULD BE READ IN WITH AS MANY SIGNIFICANT
115 C   DIGITS AS POSSIBLE BEHIND DECIMAL POINT
C***USE P(F10.0) VARIABLE FORMAT
C
              Z(1,1)=1./FLOAT(N)
              DO 4 J=2,IP
120                Z(1,J)=0.
                4 Z(J,1)=0.
                DO 10 I=1,IP
                DO 10 J=1,IP
                H(I,J)=0.
125                IF (I.EQ.J) H(I,J)=1.
                10 CONTINUE
                DO 11 J=2,IP
                11 H(1,J)=-MEAN(J)
                DO 12 I=1,IP
130                DO 12 J=1,IP
                SUM=0.
                DO 13 K=1,IP
                13 SUM=SUM + H(I,K)*Z(K,J)
                12 X(I,J)=SUM
135                DO 14 I=1,IP
                DO 14 J=1,IP
                SUM=0.
                DO 15 K=1,IP
140                15 SUM=SUM + X(I,K)*H(J,K)
                14 Z(I,J)=SUM
                DO 16 I=1,IP
                DO 16 J=1,IP
                16 R(I,J)=Z(I,J)
C
145 C***B IS XTX INVERSE
C
              GO TO 100
C
C***OPTION 2
150 C
              5 DO 17 I=1,IP
                DO 17 J=1,IP
                17 X(I,J)=0.
C
155 C***READ DATA AND COMPUTE XTX
C
              DATA(1)=1.
              DO 18 II=1,N
              READ (5,FMT) (DATA(J),J=2,IP)
160                DO 19 I=1,IP
                DO 19 J=1,IP
                19 X(I,J)=X(I,J) + DATA(I)*DATA(J)
                18 CONTINUE
                DO 21 I=1,IP
165                DO 21 J=1,IP

```

```

PROGRAM      CONFIDE
      21 R(I,J)=X(I,J)
C
C*** INVERT XTX
C
170      CALL INVERT(IP,R)
      100 PER=(1.-ALPHA)*100.
      PRINT 101,NCI,N,P,OPTION,SIGMA,T,PER
      101 FORMAT(1H1,CONFIDENCE INTERVALS FOR E(Y) //1X,15,2X,INTERVALS A
175      IRE COMPUTED//1X,15,2X,OHSEHVATIONS//1X,15,2X,VARIABLES//1X,OPT
      2ION = //12,10X,SIGMA SQUARED = //F12.5,10X,T VALUE = //F9.4//1X,
      3F6.1,2X,PER CENT CONFIDENCE INTERVALS ARE COMPUTED*)
      PRINT 102
      102 FORMAT(1H0,XTX INVERSE//)
      DO 103 I=1,IP
180      103 PRINT 104,(R(I,J),J=1,IP)
      104 FORMAT(1H ,R(E1*.7,2X))
      IF(OPTION.EQ. 1) GO TO 200
      PRINT 104
185      108 FORMAT(1H0,XTX //)
      DO 109 I=1,IP
      109 PRINT 104,(X(I,J),J=1,IP)
      PRINT 105
      105 FORMAT(1H0,UNDER OPTION 2, AS A CHECK, XTX IS MULTIPLIED BY ITS I
190      NVERSE//)
      DO 106 I=1,IP
      DO 106 J=1,IP
      SUM=0.
      DO 107 K=1,IP
195      107 SUM = SUM + X(I,K)*R(K,J)
      106 Z(I,J)=SUM
      DO 110 I=1,IP
      110 PRINT 104,(Z(I,J),J=1,IP)
      200 CONTINUE
C
200      C***COMPUTE INTERVALS
C
      PRINT 51,10
      51 FORMAT(1H1,///.10AH,/)
      V(1)=1.
205      KKK=0
      DO 300 IC=1,NCI
      READ 2,(V(I),I=2,IP)
      DO 111 J=1,IP
      SUM=0.
210      DO 112 I=1,IP
      112 SUM=SUM + V(I)*R(I,J)
      111 VV(J)=SUM
      SUM=0.
      SUMH=0.
215      DO 113 I=1,IP
      SUM=SUM + VV(I)*V(I)
      113 SUMH=SUMH + BETA(I)*V(I)
      211 CON=T*SQRT(SIGMA*SUM)
      212 CLEFT=SUMH - CON
220      CRIGHT=SUMH + CON

```

```

PROGRAM      CONFIDE
      PRINT 114,IC
114  FORMAT(1H0,/,11H***INTERVAL,I3.3H***)
      II=P/10
      II=II + 1
225     K=1
      KK=10
      DO 115 I=1,II
      IF (KK.GT,P) KK=P
      KK=K + 1
230     KKK = KK + 1
      PRINT 116,(J,J=K,KK)
116  FORMAT(1H0,*,VARIABLE           *,10(1H(.I2.1H),7X))
      PRINT 117,(V(J),J=KK,KKM)
117  FORMAT(1H ,*VALUE           *,10(F10.2,1X))
235     K=K + 10
115  KK=KK + 10
      PRINT 120,PER,CLEFT,CRIGHT ,SUMH
120  FORMAT(1H0,FS.1,*,*,*PER CENT CONFIDENCE INTERVAL FOR E(Y) IS  *.2X
      1,1H(*E1*,7.3H , *E1*,7.1H)/4*X,*E(Y) =*,E23.7)
240     KKK=KKK+1
      IF (KKK.FQ.6)GO TO 130
      GO TO 300
130  PRINT 132
132  FORMAT(*1*)
245     KKK=0
300  CONTINUE
299  STOP
      END

```

```

SUBROUTINE  INVERT
      SUBROUTINE INVERT(N,A)
$IRFTC INVERT
C      SUBROUTINE FOR MATRIX INVERSE FISHERS SUBROUTINE
C      INVERSE IS RETURNED AS MATRIX A
5      C      DIMENSION IS N
      DIMENSION A(16,16)
      DO 3 I=1,N
      R=A(I,I)
10     A(I,I)=1.0
      DO 1 K=1,N
1     A(I,K)=A(I,K)/R
      DO 3 J=1,N
      IF (I.EQ.J) GO TO 3
15     B=A(J,I)
      A(J,I)=0.
      DO 2 K=1,N
2     A(J,K)=A(J,K)-B*A(I,K)
3     CONTINUE
      RETURN
20     END

```

CONFIDENCE INTERVALS FOR E(Y)

12 INTERVALS ARE COMPUTED
298 OBSERVATIONS
2 VARIABLES

OPTION = 1 SIGMA SQUARED = 5.31350 T VALUE = 2.5760

99.0 PER CENT CONFIDENCE INTERVALS ARE COMPUTED

XTX INVERSE

.8854777E-02	-.1529854E-02	.4210161E-04
-.1529854E-02	.8173540E-03	-.3225000E-04
.4210161E-04	-.3225000E-04	.1399000E-05

***SOIL WATER POTENTIAL AT 20 CM IN SHINGLE LOAM SOIL FOR GROWING SEASON 1971**

INTERVAL 1

VARIABLE	(1)	(2)
VALUE	2.20	2.16

99.0 PER CENT CONFIDENCE INTERVAL FOR E(Y) IS (-.1937413E+01 , -.8466351E+00)
E(Y) = -.1392024E+01

INTERVAL 2

VARIABLE	(1)	(2)
VALUE	0.00	0.00

99.0 PER CENT CONFIDENCE INTERVAL FOR E(Y) IS (-.1331220E+01 , -.2137004E+00)
E(Y) = -.7724600E+00

INTERVAL 3

VARIABLE	(1)	(2)
VALUE	0.00	0.00

99.0 PER CENT CONFIDENCE INTERVAL FOR E(Y) IS (-.1331220E+01 , -.2137004E+00)
E(Y) = -.7724600E+00

INTERVAL 4

VARIABLE	(1)	(2)
VALUE	1.00	18.30

99.0 PER CENT CONFIDENCE INTERVAL FOR E(Y) IS (-.3798262E+01 , -.2773798E+01)
E(Y) = -.3286030E+01

INTERVAL 5

VARIABLE	(1)	(2)
VALUE	3.20	64.32

99.0 PER CENT CONFIDENCE INTERVAL FOR E(Y) IS (-.8801964E+01 , -.7932391E+01)
E(Y) = -.8367180E+01

INTERVAL 6

VARIABLE	(1)	(2)
VALUE	4.20	89.46

99.0 PER CENT CONFIDENCE INTERVAL FOR E(Y) IS (-.1076427E+02 , -.9931556E+01)
E(Y) = -.1034791E+02

INTERVAL 7

VARIABLE	(1)	(2)
VALUE	9.30	237.15

99.0 PER CENT CONFIDENCE INTERVAL FOR E(Y) IS ($-.1944626E+02$, $-.1841869E+02$)
 E(Y) = $-.1893248E+02$

INTERVAL 8

VARIABLE	(1)	(2)
VALUE	15.00	360.00

99.0 PER CENT CONFIDENCE INTERVAL FOR E(Y) IS ($-.3241444E+02$, $-.3121623E+02$)
 E(Y) = $-.3181556E+02$

INTERVAL 9

VARIABLE	(1)	(2)
VALUE	17.20	371.52

99.0 PER CENT CONFIDENCE INTERVAL FOR E(Y) IS ($-.4018551E+02$, $-.3898301E+02$)
 E(Y) = $-.3958426E+02$

INTERVAL 10

VARIABLE	(1)	(2)
VALUE	23.20	564.40

99.0 PER CENT CONFIDENCE INTERVAL FOR E(Y) IS ($-.4885959E+02$, $-.4690470E+02$)
 E(Y) = $-.4788215E+02$

INTERVAL 11

VARIABLE	(1)	(2)
VALUE	25.00	515.00

99.0 PER CENT CONFIDENCE INTERVAL FOR E(Y) IS ($-.6011151E+02$, $-.5815341E+02$)
 E(Y) = $-.5913246E+02$

INTERVAL 12

VARIABLE	(1)	(2)
VALUE	30.00	564.00

99.0 PER CENT CONFIDENCE INTERVAL FOR E(Y) IS ($-.7638894E+02$, $-.7363314E+02$)
 E(Y) = $-.7501106E+02$

Figure 3.1. Soils map of Lynn Lake watershed.

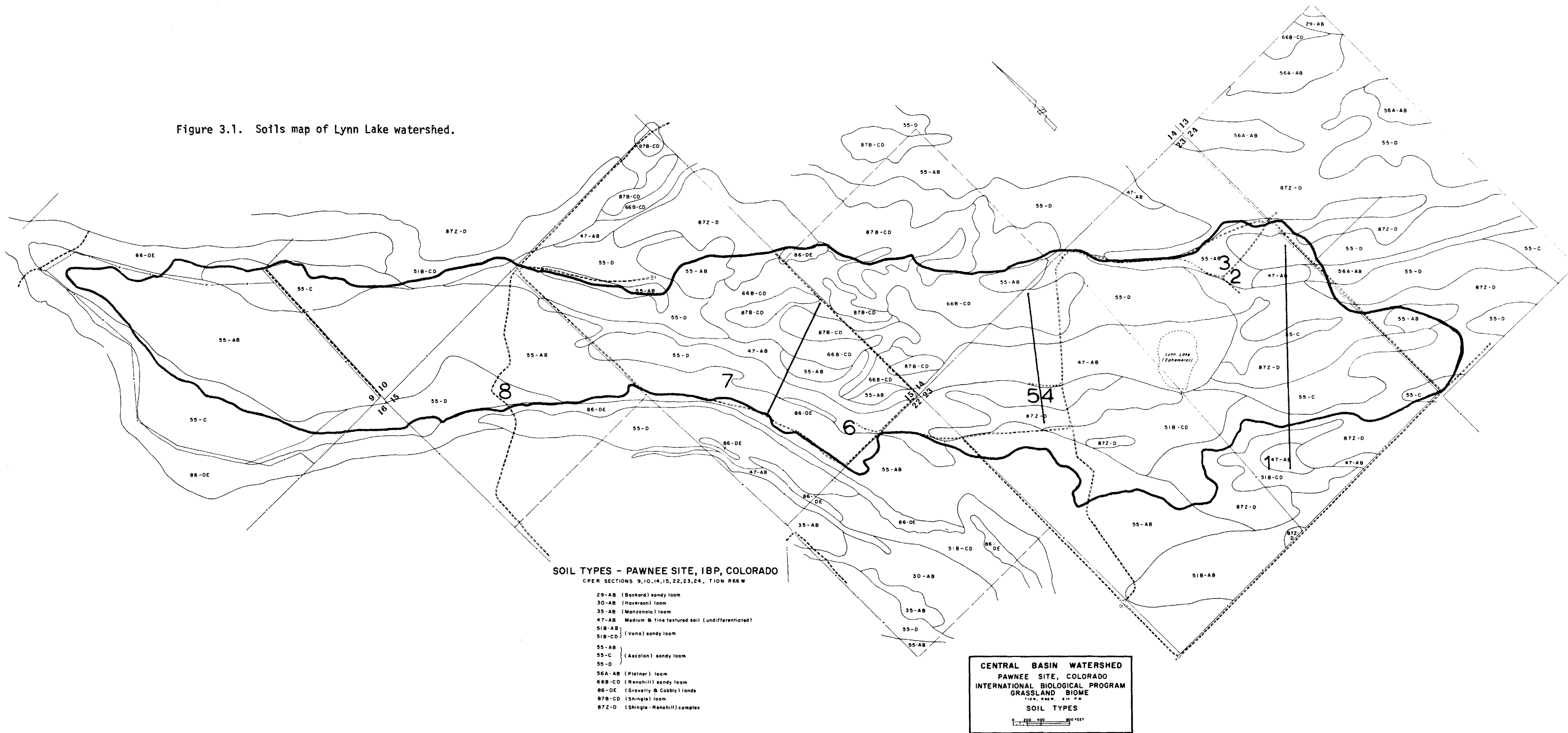

SOIL TYPES - PAWNEE SITE, IBP, COLORADO

COPER SECTIONS 9,10,14,15,22,23,24, T10N R66 W

- 29-AB (Bankard) sandy loam
- 30-AB (Haverston) loam
- 35-AB (Manzanola) loam
- 47-AB Medium & fine textured soil (undifferentiated)
- 51B-AB (Vona) sandy loam
- 55-AB (Ascalon) sandy loam
- 55-C (Ascalon) sandy loam
- 55-D (Ascalon) sandy loam
- 56A-AB (Platner) loam
- 66B-CD (Renohill) sandy loam
- 86-DE (Grovetly & Cobble) loam
- 87B-CD (Shingle) loam
- 87Z-D (Shingle-Renohill) complex

CENTRAL BASIN WATERSHED
PAWNEE SITE, COLORADO
INTERNATIONAL BIOLOGICAL PROGRAM
GRASSLAND BIOME
 T10N, R66W, S15E
SOIL TYPES

0 200 400 800 FEET

Figure 3.2. Topographic map of Lynn Lake watershed.

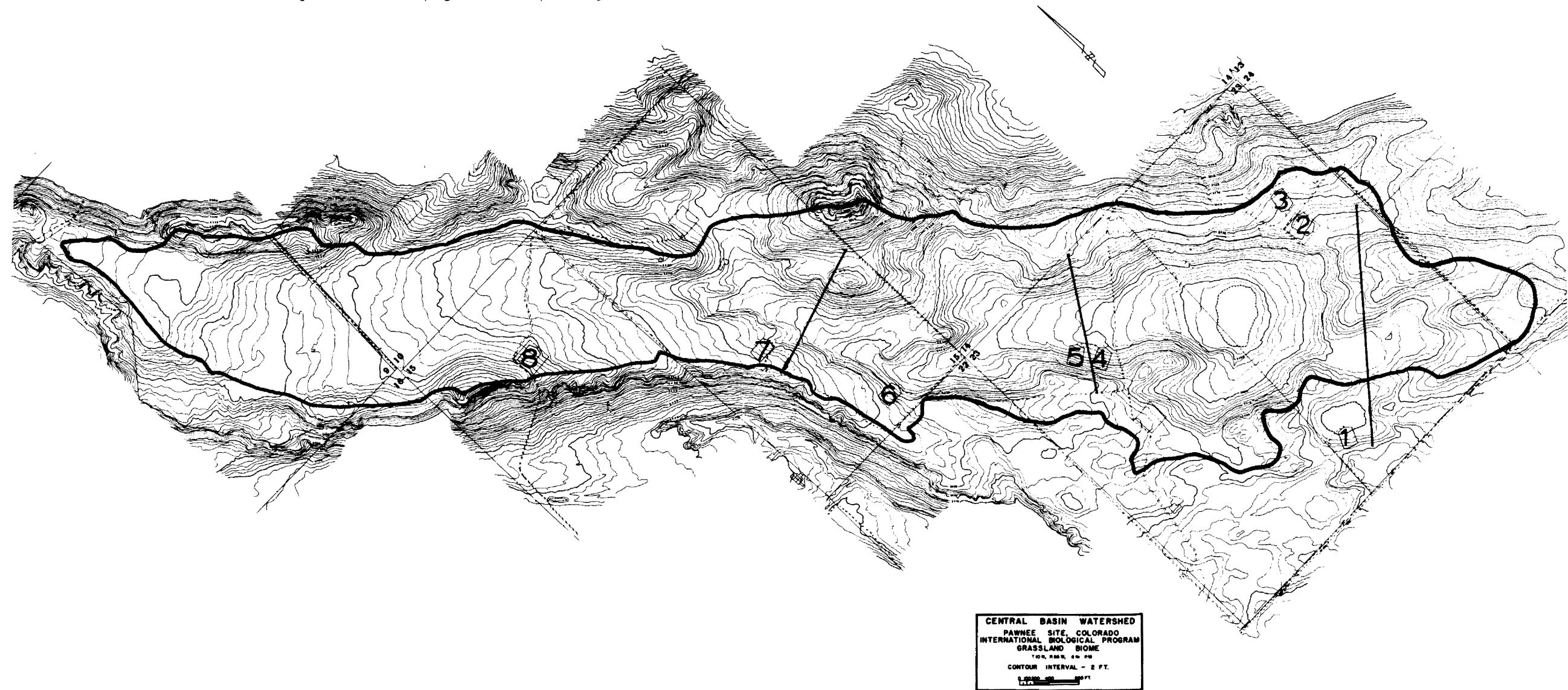

Figure 3.10. Vegetation map of Lynn Lake watershed.

