

SPATIAL DISTRIBUTION OF WATER AND NITROGEN APPLICATION UNDER CENTER PIVOT SPRINKLERS

S.C. Best and H.R. Duke
Ph.D. Candidate, Colorado State University and
Agricultural Engineer, USDA-ARS, Fort Collins, CO.

INTRODUCTION

For most management decisions, water application from center pivot systems is usually assumed to be uniform. However, significant variability of both water and chemigated chemical distribution can occur with both field location and time.

Water application depth under a center pivot system can vary because of improper (or worn) nozzle sizes, changes in pump performance over time, pressure changes caused by end-gun operation, or changes in topography across the field. Most sprinkler package designs are based upon level fields, and many systems are in operation without pressure regulators installed. If the field is not level, the flow of water out of each sprinkler will be less than design, where the elevation is higher, or greater than design where the elevation is lower. In either case, the result is uneven water application. These problems can be solved to a certain degree by using pressure regulators.

If a center pivot is used for fertigation, or if the water supply contains significant nitrate, the nitrogen will not be uniformly distributed either (Evans, 1995; Duke et al, 2000). In addition, there will be some variability of the nutrient concentration due to the effect of line pressure on the injection pump operation. Moreover, nitrogen contents vary through soils and, accordingly, may require different application rates of nitrogen.

Variability in the irrigation and nitrogen application as well as variability in the available soil water holding capacity create the potential for variability in leaching around the field. Unless excessive amounts of both water and nitrogen are applied, this leaching may affect the yield.

Researchers and farmers alike are beginning to recognize that fields are not uniform in terms of optimum input requirements and that there may be both economic and environmental benefits to differential application of water and nitrogen fertilizer rather than uniform application over entire field. These concepts of precision farming are growing rapidly, and there is little scientific evidence to back them up.

In order to apply precision farming principles to leaching reduction, yet maintain optimal yield, resource managers need cost-effective tools to identify areas that

are potentially vulnerable to leaching so that management plans can be implemented to reduce the potential pollution problems.

Computer models are among the most cost-effective tools for analyzing water resources problems, and are widely used for estimating the impact of natural resources management decisions. Some of the limitations of models, however, include the requirement for large amounts of input data, and sufficient sampling to account for spatial variability and heterogeneity that are often present. Producers are seldom able to invest the money and time required to adequately sample and characterize the variabilities of interest. For this study, we have used such models, together with GIS tools, to assess the amount of variability in application of both water and nitrogen fertilizer under two farmer-operated center pivot systems typical of those irrigating the sandy soils common to many areas of the central Great Plains. Such an analysis should give us an idea of the most productive improvements in sprinkler design or management to save costs of water and fertilizer, maintain optimum yields, and protect water quality.

APPROACH

Water control is one of the most important variables in irrigated crop production. Different types of soil have different water holding capacities, therefore require different water application depths and rates to reach field capacity and to minimize runoff and deep percolation. Because of this possibility of deep percolation which can carry nitrogen fertilizer beyond the reach of roots, water management is equally important to nitrogen management.

Precision farming is a tool that may provide potential for better management of these resources. Precision farming has been used primarily for preseason nutrient application and for mapping of harvest yields; only limited attention has been given to differential application of water and chemicals in irrigation crop production. The use of GPS and GIS technologies and advances in computer simulation have made the precision farming approach practical. This presentation is limited to determining the spatial and temporal variability of irrigation water and of the various sources of nitrogen fertilizer available to the crop during the growing season.

Experimental Site

This study focused on two center pivot irrigated corn fields in 1999, one of 170 ac, the other 130 ac. Results from the second of these fields, located northeast of Wiggins, Colorado in Morgan County will be shown in this presentation. The soils are coarse textured Valentine and Valentine-Dwyer sands and Bijou loamy sand.

This field has about 26 ft difference in elevation, as shown in Figure 1.

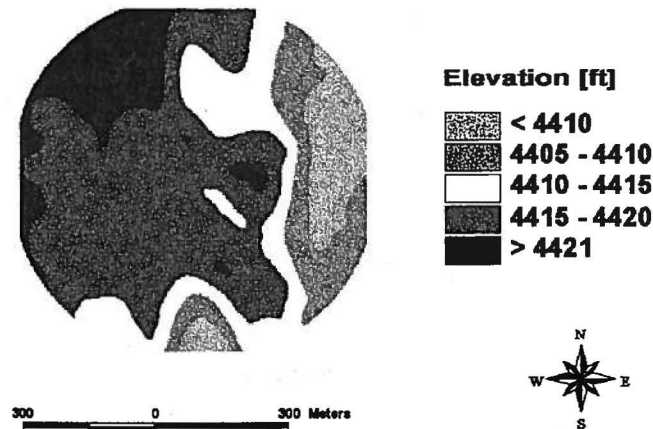

Figure 1. Elevation surface of center pivot field.

Irrigation System

A USDA developed center pivot evaluation and design program, CPED (Heermann and Spofford, 1998), was used to estimate spatial water application by the irrigation system. This program was used to compute the sprinkler hydraulics at radial intervals of 10 ft along the pipeline and at 5° increments of azimuth. The program accounts for the topography along each radius, end gun operation at that angle, and pipeline and pump hydraulics. Computed irrigation depths were compared with results of a catch can analysis to assure accuracy of the computer simulation. This analysis created a data set in polar coordinates. A CAD program was used to create an array of polygons, 25 ft in length at each 5° increment.

This set of polygons was spatially joined within the GIS program with the water application array, and the average depth of water applied computed from the CPED-estimated points falling within each polygon. Irrigation history was collected both manually and by data loggers which queried the computerized pivot panels at 15 minute intervals. This log of operating speed, position, and sprinkler line pressure was used as input to CPED to compute spatial and temporal seasonal depth of water applied.

Chemical Application

Approximately one-half the total available N was applied by fertigation during the growing season. Fertigation injection rate was determined at 15 minute intervals during application by logging the depth of liquid in the UAN storage tank (Figure 2).

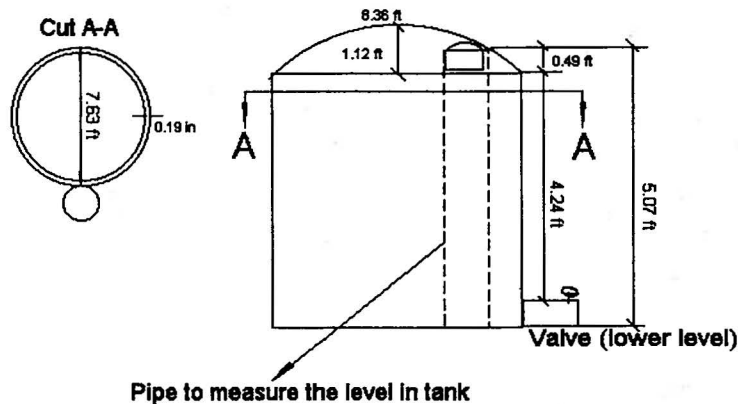

Figure 2. Diagram of tank level UAN solution measurement.

The pivot was equipped with an electric powered injection pump, which was expected to pump at a more uniform rate than the pressure-dependent water powered pump. Both line pressure and sprinkler lateral position were also logged at 15 minute intervals. Samples of concentrated UAN and water/UAN solutions were collected periodically for lab analysis to verify N concentration.

RESULTS AND DISCUSSION

The seasonal irrigation application under the center pivot during the 1999 season is showing in figure 3. The mean weighted (by area) seasonal depth of irrigation was 20.5 inches for the season. The uniformity coefficient was 0.89, which has historically been considered quite uniform. However, this uniformity coefficient still requires that 20% more water that the crop actually uses must be applied to deliver sufficient water to the drier quarter of the field!

As we can see from figure 3, the topography of the area (Figure 1), plays an important role in the spatial distribution of water under the pivot. The higher areas have lower water application, as we can see in the north and southeast areas of the field. The lower areas have higher water application as we can see in the northwest area.

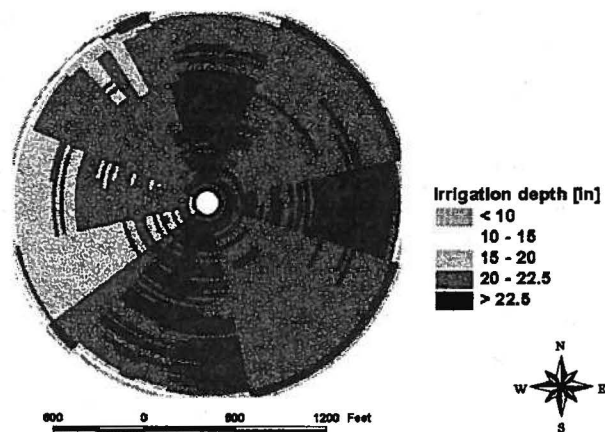

Figure 3. Seasonal irrigation distribution under center pivot - 1999.

The effect of topography is accentuated by turning the end gun on and off. When the end gun is turned on, the pressure in the system is reduced and the sprinkler heads apply less water. On the other hand, when the end gun is off, the pressure in the system increases and more water is applied. This phenomenon can be seen in Figure 3; when the end gun is off (between 35-50, 100-115, 165-175, and 315-330 degrees) there are segments with higher application, and lower application when the end gun is on. The rings of lower and higher application in the edge of the center pivot (figures 3), are due to improperly sized nozzles and improper angle settings on the end gun.

The spatial distribution of nitrogen from all significant sources was evaluated for the 1999 season on a 250 x 250 foot grid. Preseason soil samples were collected to determine the residual N. The average N carryover in these coarse soils was 31 pounds per acre. Preplant and starter fertilizer added 75 pounds per acre N. Soil organic matter was determined for each grid and used to estimate in-season mineralization of N, averaging 28 pounds per acre. The average concentration of nitrate N in the groundwater during the season was 5 ppm, which resulted in an additional 23 pounds per acre.

Figure 4 shows the seasonal spatial nitrogen application (lb/ac) by fertigation under the pivot. Comparing Figure 4 with Figure 3 shows that the behavior of the nitrogen application is not exactly the same as that of water application. There is high nitrogen application was under the north area, where elevations are low (Figure 1) and water application high (Figure 3). We can also see the effect of the end gun turning on and off. In the high elevation areas (from 130 to

230 degrees) the high pressure in the mainline reduces the injection rate. Even so, we have less water applied in those areas, and less nitrogen application. This variability in nitrogen application affects the nitrogen uniformity application with a reduction of the uniformity from the 0.89 (uniformity of the water application) to a value of 0.76. This value of nitrogen uniformity requires that the total N applied be 45% more than the crop needs just to assure that there is enough N to meet crop needs in the average of the 32 acres of the field receiving the least amount (Duke, et al, 1991). Thus, it is important that the uniformity of water application be quite high if the system is to be used for fertigation. The use of pressure regulators may help achieve a uniform water application when there is significant topographic variation or when an end gun is used.

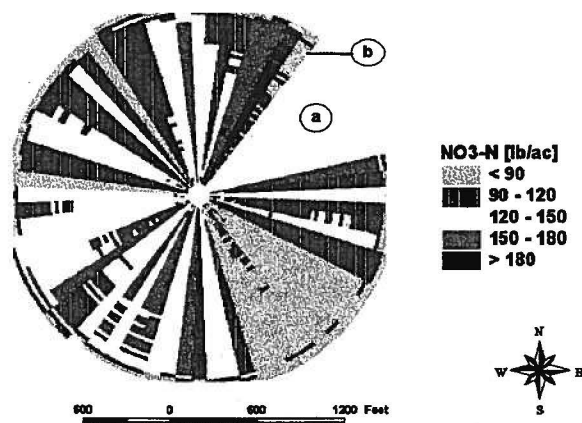

Figure 4. Spatial nitrogen application (lb/ac) by fertigation in 1999.

The available nitrogen from each source, as shown in Table 1, was summed for the season for each of the 250 x 250 ft grid cells. Figure 5 shows the distribution of total N available to the crop during the 1999 growing season.

We can use the water and nitrogen spatial application to match with soil properties in order to adjust the amount of water and nitrogen spatially applied. Using the spatial distribution of water and nitrogen in conjunction with scheduling of irrigation and fertigation could be useful to optimize the water resources and may reduce ground water contamination by nitrogen.

Before the 2000 irrigation season, the pivot was renozzled using pressure regulators. As a result, the uniformity coefficient was increased to 0.96, which reduces the necessary overapplication of water from 20% to 6%. This improvement in water uniformity will not alone improve the N fertigation uniformity by a like amount because the total water flow is still reduced when the

end gun is turned off. The fertilizer injection rate is not correspondingly reduced, Table 1. Sources of N available to the crop during the 1999 growing season.

Source	Pounds per acre	
	Mean	Std. Dev.
Residual	31.4	9.3
Preplant	50.0	-
Starter	25.0	-
Mineralization	28.1	3.9
Irrigation Water	23.1	2.6
Fertigation	118.7	31.3
Total	276.4	35.1

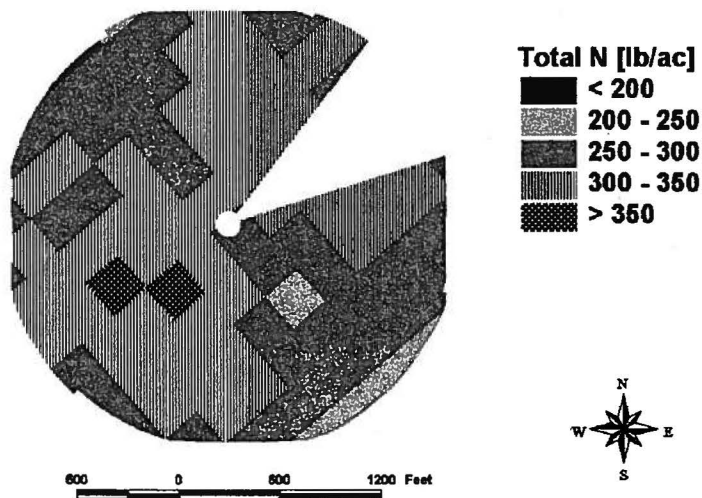

Figure 5. Distribution of total available nitrogen during the growing season.

however, resulting in a higher concentration of fertilizer in the water, and greater application per unit area. Thus, additional changes in management are necessary to achieve uniform fertigation. Although additional testing under various conditions is necessary, the concept of use precision approach to optimize the water and nitrogen resources applied appears to be very workable.

REFERENCES

1. Duke, H.R., S.C. Best, and D.G. Westfall. 2000. Spatial distribution of available nitrogen under center pivot sprinklers. Proc. 4th Nat'l. Irrigation Symp. ASAE, Phoenix, Az.
2. Duke, H.R., D.F. Heermann and L.J. Dawson. 1991. Appropriate depths of application for scheduling Center Pivot Irrigations. Trans. of the ASAE 35(5):1457-1464.
3. Evans, R.G., S. Han and M.W. Kroeger. 1995. Spatial distribution and uniformity evaluations for chemigation with center pivots. Trans. of the ASAE 38(1):85-92.
4. Heermann, D.F. and T.L. Spofford. 1998. Evaluating center pivot irrigation systems. ASAE Paper 98-2068. ASAE, St. Joseph, MI.