

THESIS

MEASUREMENT OF DIRECT NITROUS OXIDE EMISSIONS FROM  
MICROALGAE CULTIVATION UNDER OXIC AND ANOXIC CONDITIONS

Submitted by

Kelly Dawn Fagerstone

Department of Mechanical Engineering

In partial fulfillment of the requirements

For the Degree of Master of Science

Colorado State University

Fort Collins, Colorado

Summer 2011

Master's Committee:

Advisor: Anthony Marchese  
Co-Advisor: Thomas Bradley

Susan De Long

## ABSTRACT

### MEASUREMENT OF DIRECT NITROUS OXIDE EMISSIONS FROM MICROALGAE CULTIVATION UNDER OXIC AND ANOXIC CONDITIONS

Lifecycle assessments (LCA) of microalgae-based biofuels have demonstrated net greenhouse gas (GHG) emissions reductions, but limited data exist on direct emissions of GHG's from microalgae cultivation systems such as open raceway ponds (ORP) or photobioreactors (PBR). For example, nitrous oxide ( $N_2O$ ) is a potent GHG that has been detected from microalgae cultivation. However,  $N_2O$  emissions have not been experimentally quantified to determine their impact on overall lifecycle assessment of the microalgae-to-biofuels process. Theoretical calculations using the Intergovernmental Panel on Climate Change standards for terrestrial crops (1% of available nitrogen applied as fertilizer is converted to  $N_2O$ ) suggest the potential for significant levels of  $N_2O$  from microalgae cultivation. In this study, microalgae species *Nannochloropsis salina* was cultivated with nitrate under conditions representative of PBR and ORP growth conditions with diurnal light-dark cycling. To examine the effect of dissolved oxygen on  $N_2O$  emissions, experiments were conducted with an air headspace and nitrogen headspace, respectively. During these experiments  $N_2O$  emissions were quantified

utilizing Fourier Transform Infrared spectrometry. Under a nitrogen headspace, N<sub>2</sub>O emissions were elevated during dark periods and minimal during light periods. Under an air headspace, N<sub>2</sub>O emissions were negligible for both the light and dark periods. The experimental results show that N<sub>2</sub>O production was induced by anoxic conditions with nitrate present in the growth media, suggesting that N<sub>2</sub>O was produced by denitrifying bacteria within the microalgal growth media. The presence of denitrifying bacteria was verified through PCR-based detection of *norB* genes, which encode bacterial enzymes that produce N<sub>2</sub>O. Furthermore, antibiotic treatments inhibited N<sub>2</sub>O emissions. Application of these results to LCA and potential strategies for management of growth systems to reduce N<sub>2</sub>O emissions are discussed.

## ACKNOWLEDGEMENTS

I gratefully acknowledge financial support by the National Alliance for Advanced Biofuels and Bioproducts. I would also like to thank all of Solix BioSystems for the opportunity to do this research and the generous use of their equipment, facilities, and microalgae expertise.

I would like to specifically thank Jason Quinn for all of the help he provided. This thesis is based on a research question that came up in his work and he spent many hours teaching me the ins and outs of microalgae cultivation as well as helping with the setup of the experiments and the data collection.

Without the generous support of these individuals and groups, I would not have been able to complete this research.

## TABLE OF CONTENTS

ABSTRACT.....	ii
ACKNOWLEDGEMENTS.....	iv
TABLE OF CONTENTS.....	v
LIST OF TABLES.....	vii
LIST OF FIGURES.....	ix
NOMENCLATURE.....	xii
I. INTRODUCTION.....	1
II. METHODS AND MATERIALS.....	9
A. Cultivation Techniques.....	9
B. N <sub>2</sub> O Monitoring Equipment and Techniques.....	15
C. DNA Extraction and PCR Conditions.....	19
III. BASELINE GROWTH STUDY AND CONTROL OF PH.....	22
A. Baseline Growth Study.....	22
B. pH Control Mechanism.....	24
IV. EXPERIMENTAL ANALYSIS OF DIRECT N <sub>2</sub> O EMISSIONS.....	28

A. Air Headspace Conditions: Growth, Nitrate, and N <sub>2</sub> O Results .....	28
B. Nitrogen Headspace Conditions: Growth, Nitrate, and N <sub>2</sub> O Results.....	32
V. VERIFICATION OF N <sub>2</sub> O PRODUCTION ROUTE .....	38
A. Dissolved Oxygen Concentrations.....	38
B. Detection of Genes Involved in N <sub>2</sub> O Production.....	41
C. Antibiotic Cultivation Results.....	43
VI. ENVIRONMENTAL IMPACTS, CONTROL TECHNIQUES, AND LCA	
IMPLICATIONS .....	46
A. Large Scale N <sub>2</sub> O Emissions .....	47
B. Conditions and Control Techniques for N <sub>2</sub> O Production.....	48
C. Implications for LCA Evaluations .....	50
VII. CONCLUSION AND FUTURE WORK.....	51
VIII. APPENDIX.....	57
A. Scaling Calculations and Equations.....	57
B. Detailed Timeline of Experimental Procedure.....	66
C. SOP's: Nitrogen Assay, PCR Assay, Agarose Gel.....	69
REFERENCES .....	74

## LIST OF TABLES

Table 1: DNA primers used for PCR amplification of <i>norB</i> (nitric oxide reductases) ....	20
Table 2: Raw culture density ( $\text{g L}^{-1}$ ) for the baseline growth study. ....	23
Table 3: Daily growth rates ( $\text{g L}^{-1} \text{ day}^{-1}$ ) for the baseline growth study.....	23
Table 4: Daily growth rates ( $\text{g L}^{-1} \text{ day}^{-1}$ ) for the baseline pH study. ....	26
Table 5: Raw culture density ( $\text{g L}^{-1}$ ) for the oxic conditions. ....	31
Table 6: Raw nitrate ( $\text{NO}_3^-$ as N) concentrations ( $\text{mg L}^{-1}$ ) for the air headspace conditions. ....	32
Table 7: Raw $\text{N}_2\text{O}$ concentration (ppm) for the oxic conditions .....	32
Table 8: Raw culture density ( $\text{g L}^{-1}$ ) for the nitrogen headspace conditions. ....	36
Table 9: Raw nitrate ( $\text{NO}_3^-$ as N) concentrations ( $\text{mg L}^{-1}$ ) for the nitrogen headspace conditions. ....	36
Table 10: Raw $\text{N}_2\text{O}$ concentrations (ppm) for the nitrogen headspace conditions. The blank cells were data points that had to be removed because of human or equipment error. ....	37
Table 11: $\text{N}_2\text{O}$ concentrations of antibiotic treated microalgae cultures and percent reduction in $\text{N}_2\text{O}$ emissions over a four day growth period. ....	44

Table 12: N<sub>2</sub>O emissions scaled up for a year, assuming the nitrogen is used in 3 days,  
the growth cycle is 5 days, and volume is based on an open pond depth of 15  
cm. .... 48



## LIST OF FIGURES

- Figure 1: The denitrification pathway. The enzymes that catalyze each reaction are shown before the arrows, and the names of the genes that encode these enzymes are shown inside the parenthesis. .... 6
- Figure 2: Schematic of the three flask growth system in a shaking thermal bath ..... 10
- Figure 3: Actual growth system: Temperature and mixing maintained with a shaking water bath, light supplied with a 1000 watt daylight metal halide grow lamp, headspace gas supplied and sampled with tubing, stopcocks, and rubber stoppers..... 11
- Figure 4: Shaker table with microalgae flasks grown under continuous light with 2% CO<sub>2</sub>. These flasks were constantly maintained and used to inoculate the experiment and for DNA analysis..... 13
- Figure 5: Schematic of purge gas delivery and headspace gas sampling. Air or nitrogen gas was purged every 8 hours depending on the desired condition and the headspace was closed with the stopcocks. Headspace exhaust was sampled by pulling gases through the scrubbing tube into the syringe, creating a slight vacuum in the flask. .... 16

Figure 6: Schematic of exhaust gas analysis using an FTIR equipped with a 2 m gas cell. Cell was purged with nitrogen gas and evacuated using a vacuum pump prior to sample injection.....	17
Figure 7: FTIR calibration curve with n=10 for nitrous oxide in air up to 60 ppm with a linear regression. The linear equation was used to calculate N <sub>2</sub> O concentrations for the anoxic conditions. ....	18
Figure 8: FTIR calibration curve with n=6 for nitrous oxide in air up to 12 ppm with a linear regression. The linear equation was used to calculate N <sub>2</sub> O concentrations for the oxic conditions.....	19
Figure 9: Comparison of culture density for the baseline growth study and the alternative pH control study over a five day growth period.....	27
Figure 10: Average N <sub>2</sub> O emissions, culture density, and nitrate (from nitrate fertilizer) in growth media for three replicates of the air-filled headspace. The width of the N <sub>2</sub> O bar represents the headspace gas accumulation period. Error bars represent SD (n=9).....	30
Figure 11: Average N <sub>2</sub> O emissions, culture density, and nitrate (from nitrate fertilizer) in growth media for three replicates of the nitrogen-filled headspace. The width of the N <sub>2</sub> O bar represents the headspace gas accumulation period. Error bars represent SD (n=9). ....	34
Figure 12: Dissolved oxygen concentrations over 24 hours for the oxic conditions (solid line) and anoxic conditions (dashed line) with a five minute gas purge every eight hours. The upper limit for anoxic denitrification (0.2 ppm) is shown as the thin dashed line. <sup>51</sup> .....	40

Figure 13: PCR results visualized under UV in a 1% agarose gel. The standard DNA ladder is in the first column (labeled L), followed by the PCR amplifications of the *norB* (A), *qnorB* (B), and *cnorB* (C) genes. The bands of the expected size are indicated by the arrows..... 43

Figure 14: N<sub>2</sub>O concentrations from the anoxic periods of antibiotic treated microalgae cultures over a four day growth period. .... 45

Figure 15: The nitrification pathway with N<sub>2</sub>O as a by-product. .... 53

## NOMENCLATURE

ASP	-	Aquatic Species Program
CO <sub>2</sub>	-	Carbon Dioxide
DNA	-	Deoxyribonucleic Acid
dNTP	-	Deoxyribonucleotide triphosphate (Generic for the four deoxyribonucleotides: dATP, dCTP, dGTP and dTTP)
DO	-	Dissolved Oxygen
DOE	-	Department of Energy
FTIR	-	Fourier Transform Infrared
GHG	-	Greenhouse Gas
IPCC	-	Intergovernmental Panel on Climate Change
LCA	-	Life Cycle Assessment
N <sub>2</sub>	-	Nitrogen Gas
N <sub>2</sub> O	-	Nitrous Oxide
NER	-	Net Energy Ratio

$\text{NH}_4^+$	-	Ammonium
NO	-	Nitric Oxide
$\text{NO}_2^-$	-	Nitrite
$\text{NO}_3^-$	-	Nitrate
NREL	-	National Renewable Energy Lab
OD	-	Optical Density
ORP	-	Open Raceway Pond
PBR	-	Photobioreactor
PCR	-	Polymerase Chain Reaction
pKa	-	Logarithmic Acid Dissociation Constant
qPCR	-	Quantitative Polymerase Chain Reaction
RNA	-	Ribonucleic Acid
SOP	-	Standard Operating Procedure
VOC	-	Volatile Organic Compounds

## I. INTRODUCTION

The current rise and instability of petroleum based fuel costs, coupled with global warming due to the high concentrations of greenhouse gases (GHG) in the atmosphere, necessitate the development of alternative fuel sources.<sup>1</sup> As such, biofuels have recently received the attention of researchers and policy makers alike as a potential solution for many of these energy and environmental concerns. Renewable fuel sources such as biodiesel, renewable diesel and bio-ethanol are a drop-in substitute for current transportation fuels and are therefore able to be utilized immediately, making them an ideal short-term solution. Biofuels also have the potential to aid in our energy independence as well as being a cleaner burning and more environmentally friendly option than the traditional petroleum based fuels. For this reason, the Department of Energy's (DOE) Replacement Fuel Goal has mandated that by 2030, 30 percent of the U.S. motor fuel consumption be replaced with alternative fuels.<sup>2</sup>

There are many different feedstock options for biofuels currently being investigated but the most common first generation feedstocks for bio-ethanol and biodiesel are corn and soy beans, respectively. However, the use of these crops to produce biofuels competes with the food and livestock industries. With this competition for the feedstocks, corn and soy based fuels cannot meet the DOE mandates alone. Therefore, second and third generation feedstocks, including but not limited to,

microalgae, palm, miscanthus, poplar, willow, and jatropha, are being investigated for their potential to meet the DOE's fuel goals.

One such feedstock currently being investigated for biofuels is microalgae. Microalgae are a third generation feedstock and are the focus of an intensive development and commercialization effort motivated by several advantageous characteristics of microalgae-based biofuels over traditional terrestrial feedstocks. Compared to first generation feedstocks, microalgae are characterized by higher solar energy yield, year-round cultivation, the use of lower quality or brackish water, and the use of less- and lower-quality land.<sup>3-8</sup> These attributes have the potential to mitigate some of the pressures that biofuels apply to the food supply. Microalgae feedstock cultivation can also be coupled with waste streams such as combustion power plants or other CO<sub>2</sub> sources to sequester GHG emissions and has the potential to utilize nutrients from wastewater treatment facilities.<sup>9-12</sup> Lastly, the scalability of microalgae-based biofuels is proposed to be higher than first generation biofuels crops.<sup>13, 14</sup> For example, microalgae biofuel production is estimated to be 5000 gal acre<sup>-1</sup> yr<sup>-1</sup> versus the 50 gal acre<sup>-1</sup> yr<sup>-1</sup> for soybean. These advantages coupled with the potential for microalgae to meet alternative fuel goals have led to a renewed interest in microalgae biofuels; however the effectiveness with which microalgae can replace traditional transportation fuel sources must be critically evaluated.

Multiple life cycle assessments (LCA) have been used to critically evaluate the sustainability of microalgae based biofuels considering the two most common types of growth systems: photobioreactors (PBR) and open raceway ponds (ORP). The metrics used to evaluate the microalgae lifecycle are net energy ratio (NER) and GHG emissions

as the functional units for comparison purposes. However, these studies have unresolved problems based on simplifying assumptions due to the immaturity of the microalgae to biofuels technology. Current direct air pollution assumptions are based on the limited and dated data from the National Renewable Energy Lab (NREL) Aquatic Species Program (ASP) which ended in 1998, with the goal of showing economic viability of microalgae, not detailed environmental impacts or GHG emissions.<sup>15</sup> Only a few researchers have performed research relevant to a detailed analysis of the environmental impacts of microalgae, and much of this work comes from the aquaculture and oceanographic literature which is not entirely applicable to a biofuels process.<sup>14</sup> Other LCA direct emissions assumptions are based on the aquaculture and oceanographic literature,<sup>14, 16, 17</sup> or the Intergovernmental Panel on Climate Change (IPCC) guidelines for terrestrial crop GHG emissions,<sup>18</sup> none of which are entirely applicable to the direct N<sub>2</sub>O emissions from microalgae cultivation for biofuels. Performing an accurate LCA of the microalgae to biodiesel process requires a detailed model of each of the feedstock processing stages. However, with the current lack of environmental data for the cultivation stage, it is not possible to generate an accurate model of the environmental impacts and GHG emissions until they have been researched further.

One such GHG that will require additional research before being properly incorporated into LCA's is the production of nitrous oxide (N<sub>2</sub>O). Direct N<sub>2</sub>O production poses a significant impact on overall GHG emissions due to the high global warming potential of N<sub>2</sub>O (298 CO<sub>2</sub>-eq) and is currently being ignored or not properly included by the majority of LCA.<sup>19</sup> Some experimental studies have observed N<sub>2</sub>O emissions from microalgae cultivation, but none have provided quantification of N<sub>2</sub>O emissions in a way



where results can be translated to LCA-relevant metrics.<sup>16,17</sup> Weathers<sup>16</sup> measured N<sub>2</sub>O emissions from axenic cultures of green algae and suggested that N<sub>2</sub>O emissions from green algae when nitrite was present could be an intermediate by-product of the denitrification pathway, however no work was done to verify the production mechanism or measure the total quantity of N<sub>2</sub>O emissions. More recently, Florez-Leiva et al.<sup>17</sup> measured N<sub>2</sub>O emissions from microalgae cultivation in a full scale open pond using urea as a nitrogen source and hypothesized that oxic NH<sub>4</sub> oxidation was the most likely N<sub>2</sub>O production pathway. Again, no attempt to measure the total quantity of N<sub>2</sub>O emissions over the microalgae cultivation cycle was documented. Neither of these experimental studies presents data quantifying the direct N<sub>2</sub>O emissions from microalgae cultivation in a way that is directly applicable for use in LCA.

Although the microalgae cultures have been shown to generate direct N<sub>2</sub>O emissions during cultivation, most of the LCA's performed to date do not include this source of GHG emissions. For instance, Aresta et al.<sup>20</sup>, Lardon et al.<sup>21</sup>, and Luo et al.<sup>22</sup> detailed GHG emissions but fail to include N<sub>2</sub>O emissions from the cultivation of microalgae. Clarens et al.<sup>23</sup> used lifecycle data from the Ecoinvent database, accounting for spills and N<sub>2</sub>O emissions from biodiesel production but did not include direct N<sub>2</sub>O emissions from the growth stage. Campbell et al.<sup>24</sup> and Stephenson et al.<sup>25</sup> only considered N<sub>2</sub>O emissions from combustion, and Hirano et al.<sup>26</sup> did not include any nitrogen usage data nor N<sub>2</sub>O emissions. Batan et al.<sup>11</sup> considered direct N<sub>2</sub>O emissions from cultivation by postulating that N<sub>2</sub>O emissions were generated by denitrification. Their LCA included the energy consumption required to maintain oxygen levels during periods with nitrate present, thereby minimizing denitrification and therefore N<sub>2</sub>O

emissions, since anoxic denitrification has been shown to be a major cause of nitrogen loss in terrestrial crop N<sub>2</sub>O emissions.<sup>27</sup> However, no data existed to validate their claim that oxic conditions suppress the direct emission of N<sub>2</sub>O in microalgae cultivation. A better understanding of microalgae N<sub>2</sub>O emissions processes and quantities would not only lead to more accurate microalgae LCA, but would also be beneficial for development of microalgae cultivation practices that can minimize direct N<sub>2</sub>O emissions.

For the direct and residual biomass sources of N<sub>2</sub>O, the microalgae growth system is fundamentally different than a traditional terrestrial crop system. For terrestrial crops, N<sub>2</sub>O emissions are produced in 3 distinct ways: 1) from upstream N<sub>2</sub>O emitted during manufacture of nitrogen-based fertilizer; 2) from direct emission of N<sub>2</sub>O from the fertilizer applied to the field; and 3) from denitrification of residual biomass left in the field after harvesting. For terrestrial crop N<sub>2</sub>O emissions, the Intergovernmental Panel on Climate Change (IPCC) guideline for calculating the direct emissions assumes 0.01 kg N<sub>2</sub>O–N (kg N input)<sup>-1</sup>, which assumes that 1% of the total nitrogen applied as fertilizer is converted to N<sub>2</sub>O and the mechanism for the generation of direct N<sub>2</sub>O emissions is the anoxic denitrification by bacteria found in the soil and the intestinal tract of earthworms.<sup>18, 28-32</sup> Conversely, no N<sub>2</sub>O guidelines exist for microalgae cultivation even though N<sub>2</sub>O emissions have been observed.<sup>16, 17</sup> To achieve a favorable life cycle balance for GHG emissions for microalgal biofuels, it is critical that the direct sources of N<sub>2</sub>O emissions are understood in order to eliminate N<sub>2</sub>O emissions.

In terrestrial crop N<sub>2</sub>O emissions, denitrification has been shown to be a major cause of nitrogen loss. However, its effects on microalgae cultivation have yet to be determined.<sup>27</sup> Denitrification is known to be the production mechanism of direct N<sub>2</sub>O

emissions in terrestrial crops and is an anoxic process that follows the denitrification pathway as shown in Figure 1. The denitrification process reduces nitrate ( $\text{NO}_3^-$ ) to nitrogen gas through a multistep process, with  $\text{N}_2\text{O}$  as an intermediate product.<sup>27, 33-35</sup> The enzymes and genes involved in the denitrification process are shown in Figure 1. Complete denitrification involves the production and consumption of  $\text{N}_2\text{O}$  but during denitrification a fraction of the  $\text{N}_2\text{O}$  produced can be released into the atmosphere. Also, some denitrifiers can reduce nitrate into nitrogen gas due to the presence of genes encoding for all of the reductases, while others have a truncated pathway and are not able to convert  $\text{N}_2\text{O}$  to  $\text{N}_2$ .

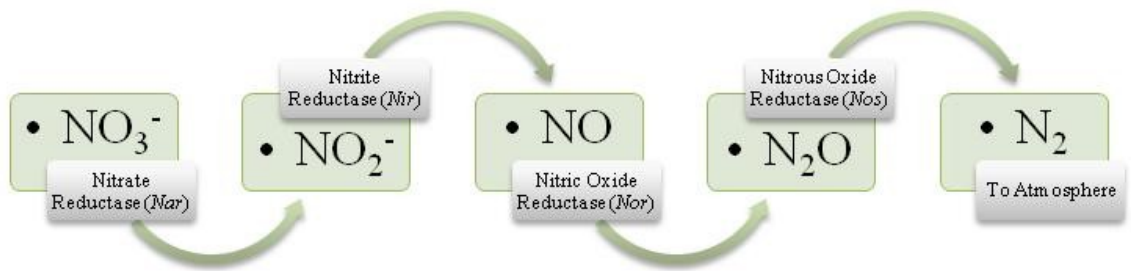

**Figure 1: The denitrification pathway. The enzymes that catalyze each reaction are shown before the arrows, and the names of the genes that encode these enzymes are shown inside the parenthesis.**

The production of  $\text{N}_2\text{O}$  in denitrification comes from the reduction of  $\text{NO}$  to  $\text{N}_2\text{O}$  catalyzed by the nitric oxide reductases *cNor* and *qNor*, encoded by the genes *norBC*.<sup>27, 30, 33, 36, 37</sup> It is possible to amplify these genes using a polymerase chain reaction (PCR) assay, in which a gene specific DNA primer is added to DNA extract and the targeted gene fragments are amplified through temperature cycling resulting in products of the expected size. The *norBC* gene has also been used as functional markers for identifying

denitrifying bacteria when using a PCR based approach.<sup>30, 37</sup> While denitrification is known to be the production pathway in terrestrial crops, a PCR amplification of the *norBC* gene was chosen in the present study to investigate the microalgae culture, as no clear consensus has been reached for the N<sub>2</sub>O production pathway in microalgae cultures.

Through careful consideration of the previous microalgae studies as well as the IPCC standards for terrestrial crop N<sub>2</sub>O emissions, it is hypothesized that the direct N<sub>2</sub>O emissions from microalgae cultures grown in this study with a nitrate based fertilizer will be due to anoxic denitrification from denitrifying bacteria within the microalgae culture. Initial calculations under this assumption using the IPCC standards for direct N<sub>2</sub>O emissions from terrestrial crops (i.e. 1% of applied nitrogen is converted into N<sub>2</sub>O) would suggest a measureable level of accumulated N<sub>2</sub>O (36 ppm) for the experimental configuration and test protocol described in the following sections, with the postulation that N<sub>2</sub>O emissions would be constant throughout the study.<sup>28-32</sup>

The denitrifying pathway is also recognized as the mechanism of N<sub>2</sub>O production in terrestrial crops and is thought to be the cause of N<sub>2</sub>O emissions in microalgae cultures by Weathers et. al.<sup>16, 18</sup> More recently and under different growth conditions, Florez-Leiva et al. stated that oxic NH<sub>4</sub> oxidation was the most likely production pathway. However, NH<sub>4</sub> oxidation is not expected in this study since an ammonia source was not present in the culture. Also, oxic denitrification is not anticipated because denitrifying bacteria grown in a high oxygen environment will not synthesize the nitrogen-reducing enzyme, thereby inhibiting the potential for N<sub>2</sub>O emission.<sup>38</sup>

Based on this understanding of the field, the development of an experimental model of the N<sub>2</sub>O production process and the management of microalgae cultivation systems to reduce N<sub>2</sub>O emission is required to fully realize the LCA GHG emissions benefits of microalgae that have been published previously. To develop this understanding and provide cultivation management strategies, an experimental study was performed to evaluate N<sub>2</sub>O emissions of microalgae cultures under bench-scale controlled oxic and anoxic conditions.

The objectives of this study were i) to quantify N<sub>2</sub>O production under conditions that are representative of PBR and ORP growth systems with diurnal light-dark cycling to inform N<sub>2</sub>O emissions accounting in LCA, ii) to develop an improved understanding of N<sub>2</sub>O production mechanisms during microalgae cultivation, and iii) to ultimately provide GHG-reducing cultivation management strategies. To meet these objectives, N<sub>2</sub>O production was quantitatively measured under conditions of varying microalgal culture oxygen concentration, light, and nitrate concentration to identify conditions that induce and repress N<sub>2</sub>O production. Additionally, the role of bacteria within the microalgal growth media on N<sub>2</sub>O emissions was considered as full-scale microalgae cultures will not be maintained axenic. Thus, the N<sub>2</sub>O production mechanism was investigated using molecular biological techniques (i.e., PCR assays) targeting bacterial genes involved in N<sub>2</sub>O production. Further verification of the N<sub>2</sub>O production route was through the measurement of N<sub>2</sub>O emissions from microalgae cultures grown with the addition of antibiotics. The discussion focuses on the implications of these experimental results for LCA of microalgae-based biofuels and the management of growth systems to reduce direct N<sub>2</sub>O emissions.

## II. METHODS AND MATERIALS

The following sections detail the materials and methods used for microalgae growth and data collection, including the cultivation techniques used to create oxic and anoxic conditions (simulating photobioreactor [PBR] and open raceway pond [ORP] growth systems), quantitative N<sub>2</sub>O measurements using Fourier Transform Infrared (FTIR) spectroscopy, and detection of genes involved in N<sub>2</sub>O production.

### A. Cultivation Techniques

In the present study, a microalgae cultivation system was developed and a test protocol was established to simulate, at bench-scale, the growth conditions in full-scale closed PBR and ORP systems. The bench-scale growth system consisted of three identical 1 liter Erlenmeyer flasks in a PolyScience shaking thermal bath. The system was operated at 140 RPM with an eccentricity setting of 9 with the thermal basin temperature maintained at 23°C. Illumination of the system was supplied using a Sun Systems Yield Master II Classic with a 1000 Watt daylight metal halide grow lamp selected for its accurate representation of solar photosynthetic active radiation (PAR). Lighting was operated on a 16 hour light, 8 hour dark period. The light intensity was measured to be 120  $\mu\text{mole}\cdot\text{m}^{-2}\cdot\text{s}^{-1}$  at the top of the flasks and 90  $\mu\text{mole}\cdot\text{m}^{-2}\cdot\text{s}^{-1}$  at the microalgae level using a Heinz Walz US-SQS/L spherical PAR sensor connected to a LI-

COR L1-250A light meter. As detailed below, sampling was performed in 8 hour increments with microalgae growth, nitrate concentration, culture pH, dissolved oxygen (DO), and N<sub>2</sub>O emissions being measured over the course of replicate four day batches. A schematic diagram of the growth system can be seen in Figure 2.

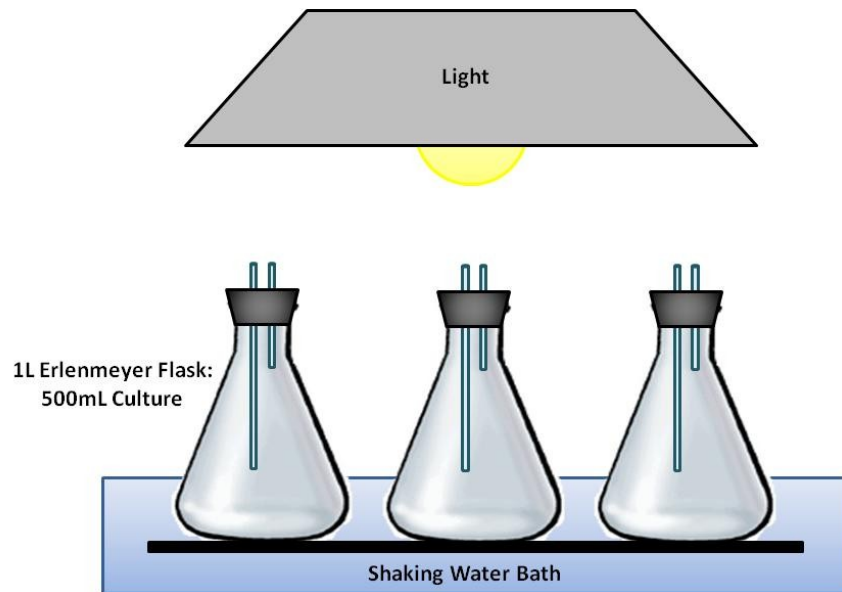

**Figure 2: Schematic of the three flask growth system in a shaking thermal bath**

A photograph of the actual experimental setup is shown below in Figure 3.



**Figure 3: Actual growth system: Temperature and mixing maintained with a shaking water bath, light supplied with a 1000 watt daylight metal halide grow lamp, headspace gas supplied and sampled with tubing, stopcocks, and rubber stoppers.**

Industrial-scale PBR and ORP growth conditions were simulated at laboratory scale by cultivating microalgae under a nitrogen-filled headspace or an air-filled headspace, respectively. The inert (nitrogen gas) headspace was used to simulate a closed PBR as the majority of full-scale PBR growth systems have little or no gaseous headspace. To simulate the growth conditions of a well-mixed ORP, the headspace of the reactors were filled with air. It should also be noted that the air-filled headspace is also representative of a closed PBR sparged with air or a CO<sub>2</sub>-air mixture at night to maintain DO concentrations.



### *1. Organism, Culture Media, and Inoculation*

Microalgae species *Nannochloropsis salina* 1776 was originally obtained by Solix BioSystems from the Provasoli-Guillard National Center for Culture of Marine Phytoplankton. The nutrient rich growth media was produced by modifying f/2 growth media to a salinity of 20 g L<sup>-1</sup> and adding 10 mM NO<sub>3</sub><sup>-</sup> L<sup>-1</sup>, 7.9 mM PO<sub>4</sub><sup>-</sup> L<sup>-1</sup>, and 1 mL L<sup>-1</sup> Guillard trace metals. The nutrient-rich growth media was filtered using a 0.2 micron absolute filter prior to inoculation. Cultures were inoculated at 1 g dry mass L<sup>-1</sup> and typically harvested at 2 g L<sup>-1</sup> over a 4 day batch. The cultures were not maintained axenic to better represent a real full scale microalgae growth system in which there may be bacteria within the microalgal growth media. For consistency at inoculation, inoculum was concentrated by centrifuging the harvested culture at 1000 × g for 20 minutes, the supernatant was discarded, and the inoculum was re-suspended with fresh nutrient media. Three 2 L flasks were maintained for the duration of the experiment with microalgae cultures grown under a low level 24 hour light and 2% CO<sub>2</sub> and were used to inoculate the flask system and to supply microalgae culture for the DNA analysis. These flasks were inoculated at a culture density of 1 g L<sup>-1</sup> dry mass and grown to 3 g L<sup>-1</sup>. Figure 4 shows a photograph of these flasks.

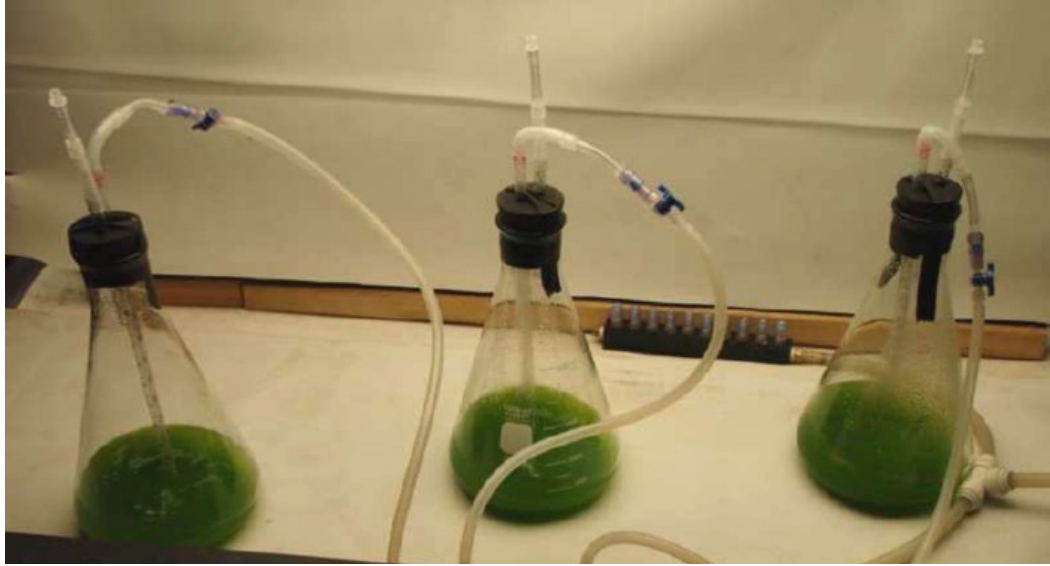

**Figure 4: Shaker table with microalgae flasks grown under continuous light with 2% CO<sub>2</sub>. These flasks were constantly maintained and used to inoculate the experiment and for DNA analysis**

## *2. Monitoring and Control of pH*

The culture pH was monitored twice daily with an YSI pH 100 temperature and pH probe. For analysis purposes, exhaust gases had to be concentrated in the headspace above the microalgae on an 8 hour time scale. Sodium bicarbonate (NaHCO<sub>3</sub>) was used to supply carbon to the microalgae, as it has been shown to be an effective alternate carbon source for microalgae growth when compared to sparging CO<sub>2</sub>.<sup>39, 40</sup> Upon inoculation 25 mM sodium bicarbonate was supplied with an additional 5 mM added daily. The utilization of carbon from the sodium bicarbonate inevitably leads to a rise in culture pH due to the accumulation of OH<sup>-</sup> in the media.<sup>39</sup> In order to maintain a culture pH of 7.5 ± 0.5 the culture media was buffered with the addition of 25 mM HEPES, free acid (ShineGene Molecular Biotech, Inc.). HEPES is an organic zwitterionic buffer used to buffer culture media, with concentrations of 10 to 25 mM recommended by the manufacturer. Also, as stated by the manufacturer, the concentration of HEPES must be

double that of sodium bicarbonate to supply adequate buffering. Therefore, additional pH control was done with the addition of hydrochloric acid to lower the pH within HEPES buffering range when required. Growth rates utilizing this method of pH regulation were similar to growth rates determined with CO<sub>2</sub> pH control.

### *3. Growth, Nitrate, and Dissolved Oxygen Monitoring Equipment and Techniques*

Growth monitoring was performed daily, at the beginning of the light cycle. Optical density (OD) measurements at 750 nanometers were performed on a Hach DR5000 spectrophotometer with dry mass calculated based on a predetermined correlation coefficient. Samples were prepared for an optical density reading using the following technique: Depending on the dilution required, 80-160 µL of sample was added to a 3 mL 10 mm optical path length cuvette using a 200 µL pipette. 1960-1840 µL (depending on dilution) of 0.2 micron filtered 20 g L<sup>-1</sup> salt water was pipetted into the cuvette followed by pipette mixing. Samples were diluted such that the measured optical density was in a range of 0.1 to 0.3 such that a predetermined (by Solix BioSystems) conversion of optical density to dry mass could be applied.

Nitrate concentration in the culture medium was measured daily at the beginning of the light cycle with a nitrate assay developed by Solix BioSystems using a Hach DR5000. Samples for the nitrate assay were prepared in a total volume of 5 mL and read in a 4mL quartz cuvette. Samples were diluted such that the nitrate level was within the range of the assay (1-10 mg/L); depending on the dilution, samples contained 4.4 to 4.65 mL DI water, 500 to 250 µL filtered medium, and 100 µL of 1 M HCl. Filtration was performed by centrifuging the culture sample for 3 minutes at 14000 × g. Details on the nitrate assay can be found in Appendix C.

DO concentrations were measured every 15 minutes over a 24 hour growth cycle using a Hach HQ40d meter with luminescent dissolved oxygen probe (LDO) for both headspace conditions.

#### *4. Growth Conditions for Antibiotic Treatments*

To evaluate the role of denitrifying bacteria in N<sub>2</sub>O production, microalgae were cultured with and without antibiotics under a nitrogen headspace using the methods described above. Two flasks were treated with antibiotics and a third was used as a control. As adapted from Andersen,<sup>41</sup> 100 mg·L<sup>-1</sup> of penicillin g potassium salt and 25mg·L<sup>-1</sup> streptomycin sulfate salt were added to the f/2 media at inoculation followed by a booster of 25mg·L<sup>-1</sup> penicillin and 5mg·L<sup>-1</sup> streptomycin twice daily for 4 days.

#### *B. N<sub>2</sub>O Monitoring Equipment and Techniques*

FTIR spectrometry, which has been shown to be a fast and precise N<sub>2</sub>O measurement technique, was used to quantitatively measure the accumulated mole fraction of N<sub>2</sub>O in the gaseous headspace above the microalgae cultures.<sup>42-44</sup> Sampling was performed at 8 hour increments in order to concentrate headspace N<sub>2</sub>O levels to detectible levels. Headspace gases were sampled using a 140 mL polypropylene syringe (Syringe-Monoject, 140 cc LL) and one way stopcock with sample gas passed through a scrubbing tube filled with Drierite (10-20 mesh, with Indicator, Acros Organics) and Ascarite II (CO<sub>2</sub> absorbent, 20-30 mesh, capacity: 40-50%, Acros Organics) to remove excess water vapor and CO<sub>2</sub> respectively.<sup>45,46</sup> After sampling, the headspace was purged for 5 minutes with either air or inert nitrogen gas depending on the desired simulated growth system configuration (PBR vs. ORP). For both configurations, the scrubbing

tubes were purged with nitrogen gas. A schematic diagram of the gas sampling system can be seen in Figure 5.

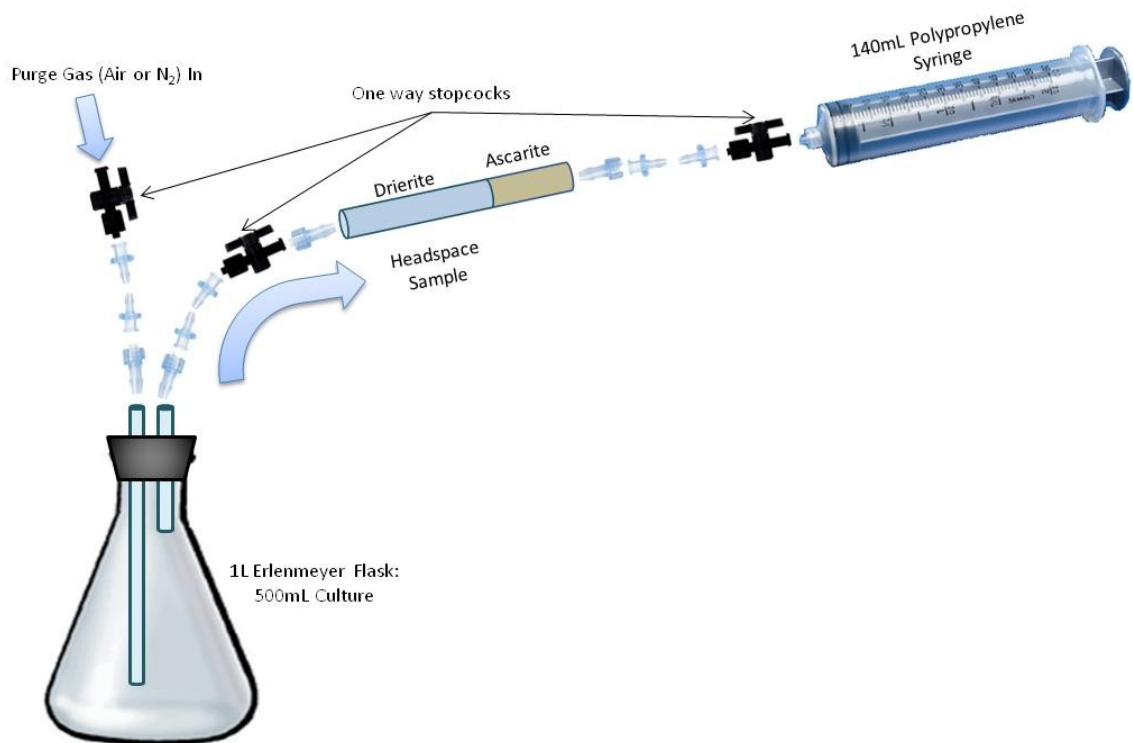

**Figure 5: Schematic of purge gas delivery and headspace gas sampling. Air or nitrogen gas was purged every 8 hours depending on the desired condition and the headspace was closed with the stopcocks. Headspace exhaust was sampled by pulling gases through the scrubbing tube into the syringe, creating a slight vacuum in the flask.**

Headspace gas samples were analyzed with a Thermo / Nicolet Magna-IR 560 E.S.P. FTIR Spectrometer equipped with a 2 meter gas cell and a liquid nitrogen cooled MCT-A detector with ZnSe windows. The gas samples were analyzed using Nicolet's OMNIC E.S.P. software. All gas samples were processed within 24 hrs to ensure sample stability.<sup>46-48</sup> To prepare for each analysis, the FTIR cell was purged with nitrogen gas for 10 minutes and evacuated to a consistent pressure with a vacuum pump. A constant

volume of headspace exhaust gas was then injected, and analyzed. A schematic of the FTIR setup and the calibration curve can be found in Figure 6.

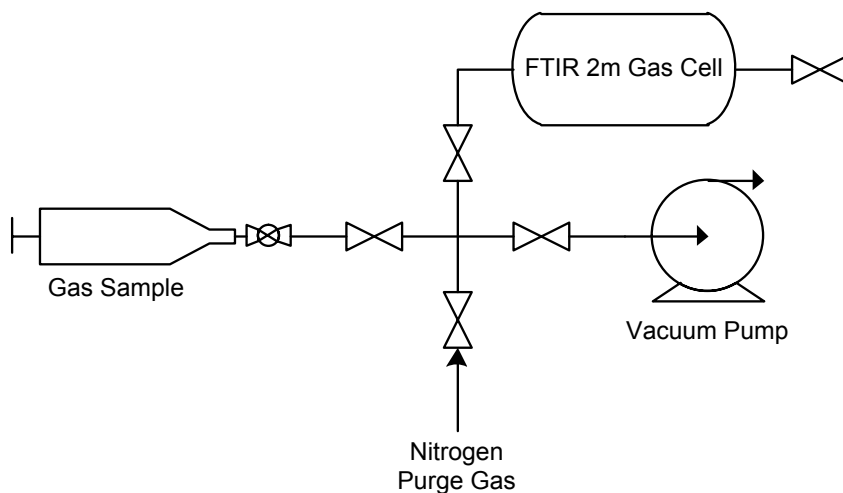

**Figure 6: Schematic of exhaust gas analysis using an FTIR equipped with a 2 m gas cell. Cell was purged with nitrogen gas and evacuated using a vacuum pump prior to sample injection.**

Analysis was performed over 128 cycles using the nitrous oxide spectra between  $2170\text{ cm}^{-1}$  and  $2250\text{ cm}^{-1}$ .<sup>49</sup> To quantify the  $\text{N}_2\text{O}$  production, calibration curves were created using gas samples with known  $\text{N}_2\text{O}$  concentrations. To prepare the calibration curves, a calibration gas was diluted with air to the specified concentration then pulled through the scrubbing tube into a syringe and injected into the FTIR in the exact same manner as the headspace samples. Theoretical calculations using the IPCC standards for terrestrial crops (1% of available nitrogen is converted into  $\text{N}_2\text{O}$ ) suggest the potential for noteworthy levels of  $\text{N}_2\text{O}$  (up to 36.2 ppm) for the experimental system presented.<sup>28-32</sup> Details on this calculation can be found in Appendix A. Therefore, an  $\text{N}_2\text{O}$  calibration gas concentration of 60 ppm<sub>v</sub> was chosen to develop a calibration curve (n=10) for nitrous oxide by diluting the calibration gas with air; it is shown in Figure 7. The

resultant calibration curve was linear from 0 to 60 ppm<sub>v</sub>, having a linear R<sup>2</sup> value of 0.9992 and the manufacturer certifies a calibration range of up to 1000 ppm. For N<sub>2</sub>O levels greater than 60 ppm, the N<sub>2</sub>O mole fraction was estimated by linear extrapolation of the 0 to 60 ppm calibration curve.

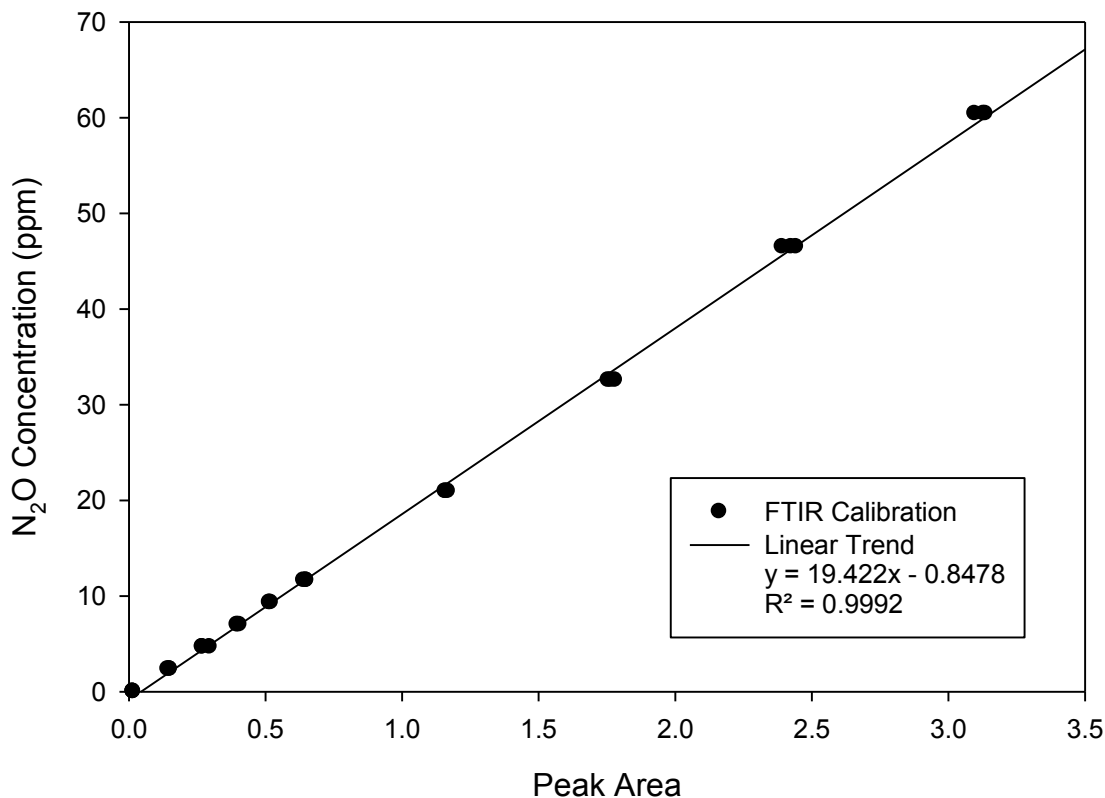

Figure 7: FTIR calibration curve with n=10 for nitrous oxide in air up to 60 ppm with a linear regression. The linear equation was used to calculate N<sub>2</sub>O concentrations for the anoxic conditions.

For greater precision, a second linear curve (n=6) was fit from 0 to 12 ppm with an R<sup>2</sup> value of 0.9988 which was used for the air headspace conditions (ORP simulation) and is shown in Figure 8.

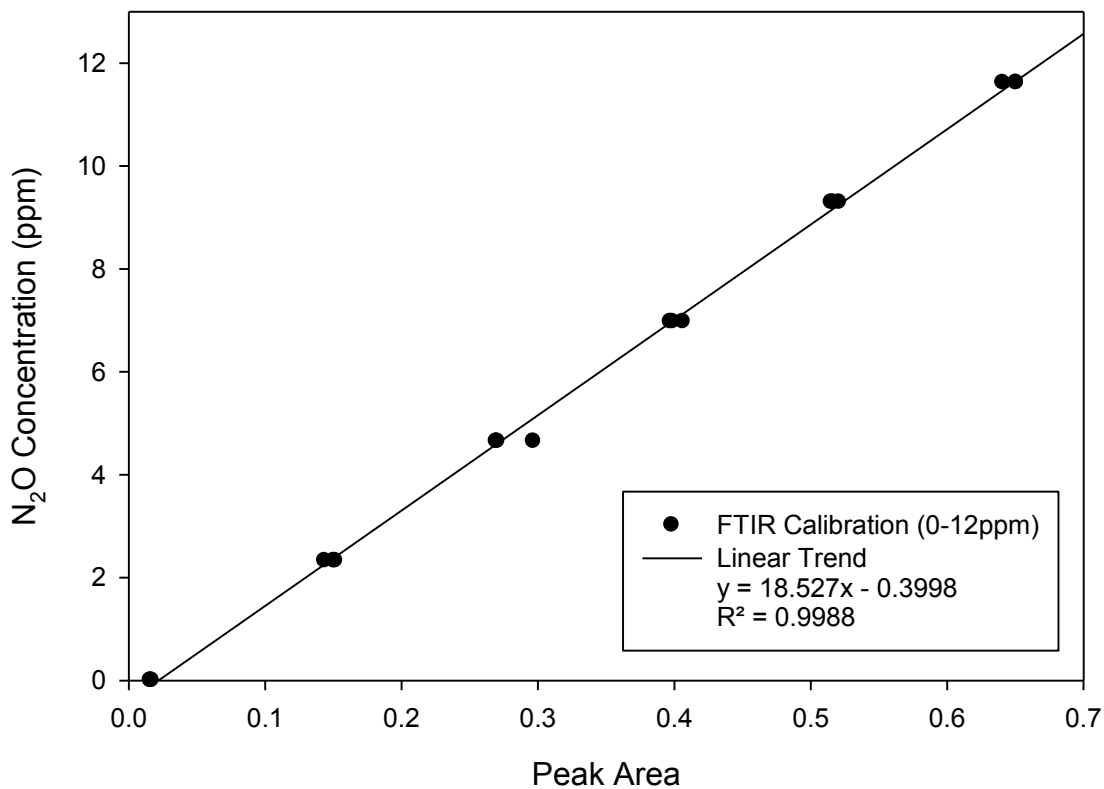

Figure 8: FTIR calibration curve with  $n=6$  for nitrous oxide in air up to 12 ppm with a linear regression. The linear equation was used to calculate N<sub>2</sub>O concentrations for the oxic conditions.

Both calibration curves displayed an extremely linear trend with  $R^2$  values of over 0.99.

### C. DNA Extraction and PCR Conditions

Prokaryotic DNA was extracted from microalgae cultures, and the *norB* gene (encoding for nitric oxide reductase, which catalyzes the reduction of NO to N<sub>2</sub>O) was analyzed to further elucidate the role of denitrifying bacteria in N<sub>2</sub>O emissions.

Microalgae were removed from the growth media by filtration with an absolute 1.2  $\mu\text{m}$  filter. The filtrate was then centrifuged at  $12,000 \times g$  for 15 minutes to pellet bacteria.

The pellet was re-suspended in phosphate buffered saline (PBS), and DNA was extracted



using an UltraClean Microbial DNA Isolation Kit (MoBio Inc.) following the manufacturer's instructions. DNA was quantified using the Quanti-iT™ dsDNA Assay Kit (Broad Range Q33130, Molecular Probes, Invitrogen).

Polymerase chain reaction (PCR) is a process in which a gene specific DNA primer is added to DNA extract and the targeted gene fragments are amplified through temperature cycling resulting in products of the expected size. PCR analysis of the microalgae cultures was performed using the specific primers that target the *norB* gene given in Table 1.

**Table 1: DNA primers used for PCR amplification of *norB* (nitric oxide reductases)**

Gene	Primers	Amplicon Size (bp)	Sequence (5'-3')*
<i>norB</i>	norB1f norB8r	670	CGN GAR TTY CTS GAR CAR CC CRT ADG CVC CRW AGA AVG C
<i>qnorB</i>	qnorB2f qnorB5r	262	GGN CAY CAR GGN TAY GA ACC CAN AGR TGN ACN ACC CAC CA
<i>cnorB</i>	cnorB2f cnorB6r	389	GAC AAG NNN TAC TGG TGG T GAA NCC CCA NAC NCC NGC

\* N = A, C, G, or T; Y = C or T; R = A or G; D = G, A, or T

PCR amplification was performed using three specific primer sets to target the *norB* genes.<sup>37, 50</sup> PCR assay conditions were adapted from Braker et al.<sup>37</sup> and Lee et al.<sup>50</sup> Briefly, PCR reactions were performed in 50 µl reactions and consisted of 1 × PCR buffer (New England Biolabs, Ipswich, MA), 40 pmol of each primer, 200 µM each deoxynucleotide triphosphate, 1.5 mM MgSO<sub>4</sub>, 2 units Taq polymerase (New England Biolabs, Ipswich, MA), 400 ng bovine serum albumin (BSA), and 70 ng of template

DNA. The following amplification program was used: initial denaturation for 5 min at 95°C, 35 cycles of denaturation for 30 s at 95°C, primer annealing for 45 s at 54°C, primer extension for 45 s at 68°C, with a final extension of 7 minutes at 68°C. PCR products (10 µl) were analyzed using 1% (wt. /vol.) agarose gel in 1 × Tris-acetate-EDTA buffer and visualized with UV excitation.

More details including standard operating procedures (SOP) and calculations can be found in the appendix.

### III. BASELINE GROWTH STUDY AND CONTROL OF PH

The baseline growth study was used to get a feeling for the growth rates of a healthy microalgae culture in the experimental setup described above, to use as a means of monitoring culture health in later studies. Next, a suitable method of pH control that would allow for the accumulation of headspace gases was developed and growth rates were compared to the baseline study. These results are given in the following sections.

#### A. Baseline Growth Study

The first step in the experimental procedure was to establish a baseline growth rate. This growth rate could then be compared to the growth rates maintained with the altered pH control methods and later the experimental runs. The baseline growth data was accomplished by growing the three flask system under a 16 hour illumination period with a nutrient rich modified f/2 media. The cultures were supplied with carbon through a continuous supply of 2% CO<sub>2</sub> in air while the lights were on. The 2% CO<sub>2</sub> also maintained a pH of between 6.8 and 8.2 for ideal microalgal health and growth rates. This method of continuous CO<sub>2</sub> sparging of the microalgae culture is the most common method and is readily utilized in large scale growth systems.

The baseline growth study was repeated twice with the microalgae cultures inoculated at 1 g L<sup>-1</sup> and allowed to grow for 5 days. OD measurements were performed

twice daily at the beginning and end of the light period. The baseline growth runs resulted in an average growth of  $0.268 \text{ g L}^{-1} \text{ day}^{-1}$ . Table 2 shows the raw culture density results for the baseline growth study.

**Table 2: Raw culture density ( $\text{g L}^{-1}$ ) for the baseline growth study.**

Run	Flask	Day 1		Day 2		Day 3		Day 4		Day 5		Day 6
		AM	PM	AM	PM	AM	PM	AM	PM	AM	PM	AM
1	1	1.03	1.30	1.33	1.67	1.64	1.87	1.77	2.03	2.07	2.42	2.54
	2	1.03	1.33	1.33	1.79	1.73	1.86	1.93	2.10	2.21	2.54	2.57
	3	1.03	1.05	1.20	1.66	1.65	1.76	1.75	2.06	2.05	2.39	2.40
2	1	0.95	1.08	1.07	1.28	1.35	1.60	1.70	1.94	1.88	2.15	2.09
	2	0.95	1.09	1.07	1.41	1.48	1.72	1.78	2.01	1.98	2.24	2.21
	3	0.95	1.06	1.13	1.33	1.40	1.59	1.76	1.87	1.90	2.16	2.15

Table 3 gives the daily growth rates for the baseline growth study resulting in an average of  $0.268 \text{ g L}^{-1} \text{ day}^{-1}$ .

**Table 3: Daily growth rates ( $\text{g L}^{-1} \text{ day}^{-1}$ ) for the baseline growth study.**

Run	Flask	Day 1	Day 2	Day 3	Day 4	Day 5
1	1	0.302	0.310	0.125	0.300	0.477
	2	0.302	0.400	0.198	0.279	0.361
	3	0.174	0.450	0.098	0.300	0.348
2	1	0.118	0.283	0.347	0.186	0.206
	2	0.125	0.407	0.298	0.196	0.239
	3	0.184	0.266	0.358	0.144	0.247

## B. pH Control Mechanism

The nature of the N<sub>2</sub>O experiment required the collection of the microalgae headspace over a period of 8 hours for analysis. Eight hours was chosen as the accumulation time for two reasons. First, the theoretical calculations using the IPCC 1% standard showed that an 8 hour accumulation of the headspace gases would result in an N<sub>2</sub>O concentration of 36.2 ppm, which would be easily detected using the FTIR. Second, an 8 hour accumulation period would allow for sampling at the beginning and end of the work day in order to collect data for both the light and dark periods. This meant that the method of supplying a continuous 2% CO<sub>2</sub> air flow was not possible as the headspace gases would be allowed to escape using this method. Therefore, a new method of supplying carbon and pH control needed to be implemented.

First, a pulsed gas delivery system was experimented with. In this case, the microalgae headspace was filled with between 5% and 20% CO<sub>2</sub> and then closed off for 8 hours. The pH and growth was monitored at the beginning and end of the accumulation period in order to dial in an ideal percentage of CO<sub>2</sub> for both maximum growth and pH control. After trying several different scenarios, the idea of a batch CO<sub>2</sub> delivery system was dropped. This was based on the fact that a high concentration of CO<sub>2</sub> was required to maintain a reasonable pH at the end of the 8 hours, resulting in a very low pH at the start of the accumulation period. The best trial resulted in a pH change from 6.3 to 9.3 over the 8 hour period, which was unacceptable since optimal pH is required to maintain a high growth rate.

A new carbon delivery and pH control method was developed since it was determined that a batch CO<sub>2</sub> delivery system was not practical for the collection of

headspace gases based on an unacceptable range of pH values. The supply of carbon was through the addition of sodium bicarbonate ( $\text{NaHCO}_3$ ) to the microalgal media at inoculation as it has been shown to be an effective alternate carbon source for microalgae growth.<sup>39,40</sup> Upon inoculation 25 mM sodium bicarbonate was supplied with an additional 5 mM added daily. Literature has stated that growth experimentation showed no difference in productivity when carbon was supplied to the culture through the sparging of  $\text{CO}_2$  or through dissolved sodium bicarbonate. However, the utilization of carbon from the sodium bicarbonate (with a pKa of 10.3) inevitably leads to a rise in culture pH due to the accumulation of  $\text{OH}^-$  in the media.<sup>39</sup> In order to maintain the culture pH, the culture media was buffered with the addition of 25 mM HEPES, free acid (ShineGene Molecular Biotech, Inc.). The manufacturer states that HEPES is an organic zwitterionic buffer commonly used to buffer culture media with a pKa of 7.5 and a buffering range of 6.8 to 8.2. A concentration of 25 mM was chosen as higher concentrations have been shown to be toxic and are not recommended. Also, the concentration of HEPES must be double that of sodium bicarbonate to supply adequate buffering. However, the amount of sodium bicarbonate required to maintain growth levels for the duration of the experiment would not allow for the HEPES concentrations to be double that of the sodium bicarbonate. Therefore, additional pH control was done with the addition of hydrochloric acid (HCl) to lower the pH within HEPES buffering range when required.

In order to verify that growth rates utilizing this method of pH regulation were similar to growth rates determined with a  $\text{CO}_2$  pH control, the growth rates and pH of the microalgae cultures were monitored daily. The microalgae cultures were inoculated with

sodium bicarbonate and HEPES at  $1 \text{ g L}^{-1}$  and allowed to grow for 6 days. Active pH control was achieved with the addition of HCl when necessary. OD measurements were performed once daily at the beginning of the light period and pH measurements were taken twice daily at the beginning and end of the light period. The baseline pH study resulted in a pH of between 6.9 and 8.3 with an average growth of  $0.257 \text{ g L}^{-1} \text{ day}^{-1}$ . The daily growth rates utilizing this alternative carbon source and pH control method (detailed in the materials and methods section) are given in Table 4 below.

**Table 4: Daily growth rates ( $\text{g L}^{-1} \text{ day}^{-1}$ ) for the baseline pH study.**

Flask	Day 1	Day 2	Day 3	Day 4	Day 5	Day 6
1	0.295	0.291	0.364	0.215	0.211	0.204
2	0.211	0.358	0.281	0.280	0.230	0.197
3	0.216	0.343	0.318	0.265	0.189	0.162

The pH values obtained under these control methods were within an acceptable range and the growth rates were comparable to the baseline growth rates. It was found that there was no statistical difference between the baseline growth rates utilizing  $\text{CO}_2$  ( $0.268 \text{ g L}^{-1} \text{ day}^{-1}$ ) and the growth rates utilizing sodium bicarbonate and the alternative pH control method ( $0.257 \text{ g L}^{-1} \text{ day}^{-1}$ ). Figure 9 compares the culture density for the baseline growth run and the alternative pH control run. A two-tailed distribution, two-sample unequal variance Student's t-test was performed resulting in a P value of 0.661 and a difference of  $0.010 \text{ g L}^{-1} \text{ day}^{-1} \pm 0.039 \text{ g L}^{-1} \text{ day}^{-1}$ . Therefore, it was concluded that the carbon supply through sodium bicarbonate and the pH control methods described above were adequate for use in the  $\text{N}_2\text{O}$  experimental runs.

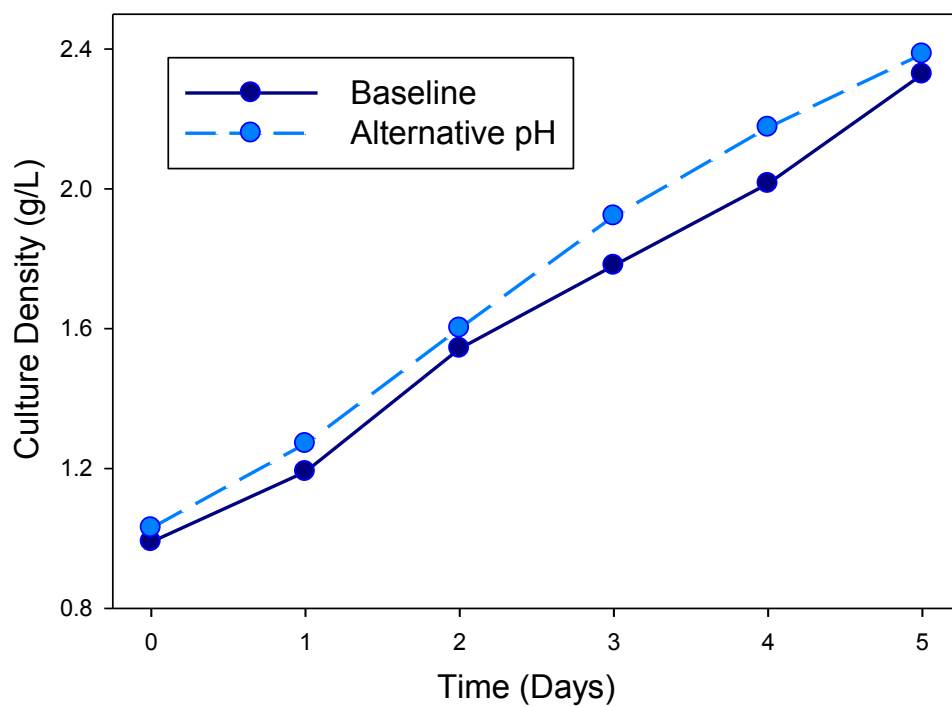

**Figure 9: Comparison of culture density for the baseline growth study and the alternative pH control study over a five day growth period.**



#### IV. EXPERIMENTAL ANALYSIS OF DIRECT N<sub>2</sub>O EMISSIONS

N<sub>2</sub>O emission results are presented in two sections based on two growth scenarios; the air headspace conditions and the nitrogen headspace conditions. The following sections detail the N<sub>2</sub>O emissions and environmental conditions for the two growth architectures represented.

##### A. Air Headspace Conditions: Growth, Nitrate, and N<sub>2</sub>O Results

In this set of experiments, the microalgae cultures were grown with a closed headspace and purged with air every 8 hours to represent a well mixed ORP. The microalgae growth rate, nitrate in the growth medium, and N<sub>2</sub>O emission concentrations were monitored over the course of three, 4 day batches for the oxic conditions, with the averaged data set presented in Figure 10. The average culture density is shown by the solid black line, while the dashed black line represents the average nitrate. The dark and light periods are illustrated by the background color with average N<sub>2</sub>O concentrations shown by the grey bars. The width of the bar shows the headspace accumulation period and the error bars represent the standard deviation for that sampling period. Figure 10 illustrates a constant average growth rate of 0.24 g L<sup>-1</sup> day<sup>-1</sup> with the nitrate (NO<sub>3</sub><sup>-</sup> as N) decreasing from 106 mg L<sup>-1</sup> to complete uptake by the microalgae within 3 days. Results show that upon the depletion of nitrate, N<sub>2</sub>O emissions decrease to zero (0.0 ppm ± 0.0 ppm, n=9).

The N<sub>2</sub>O concentrations were converted to an overall mass of N<sub>2</sub>O produced with the cumulative N<sub>2</sub>O emissions over the light periods for the days with nitrate totaling 4.9 µg. Over the same time frame with nitrate, the total cumulative N<sub>2</sub>O emissions for the dark periods were 11.4 µg. The total mass of direct N<sub>2</sub>O produced from N applied for the air-filled headspace was calculated to be  $2.98 \times 10^{-5}$  kg N<sub>2</sub>O–N (kg N input)<sup>-1</sup> (or 0.003%). By comparison, this emission factor is substantially less than the IPCC standard for terrestrial crop N<sub>2</sub>O emissions, which utilizes an emission factor for N<sub>2</sub>O emissions from the nitrogen applied of 0.01 kg N<sub>2</sub>O–N (kg N input)<sup>-1</sup> (or 1%).<sup>18</sup>

These calculations were performed by first converting the volume based N<sub>2</sub>O concentration (ppm) to a mass of total N<sub>2</sub>O emitted. Next, by rearranging Equation 1 from the IPCC direct N<sub>2</sub>O emissions literature, the mass of nitrogen (N<sub>2</sub>O–N) from the emitted N<sub>2</sub>O was found.<sup>18</sup>

$$N_2O = N_2O - N \times 44/28 \quad [E.1]$$

Lastly, the mass of nitrogen from converted N<sub>2</sub>O was divided by the total mass of nitrate as N applied to the culture resulting in a 0.003% loss of nitrogen. Details on this calculation can be found in Appendix A.

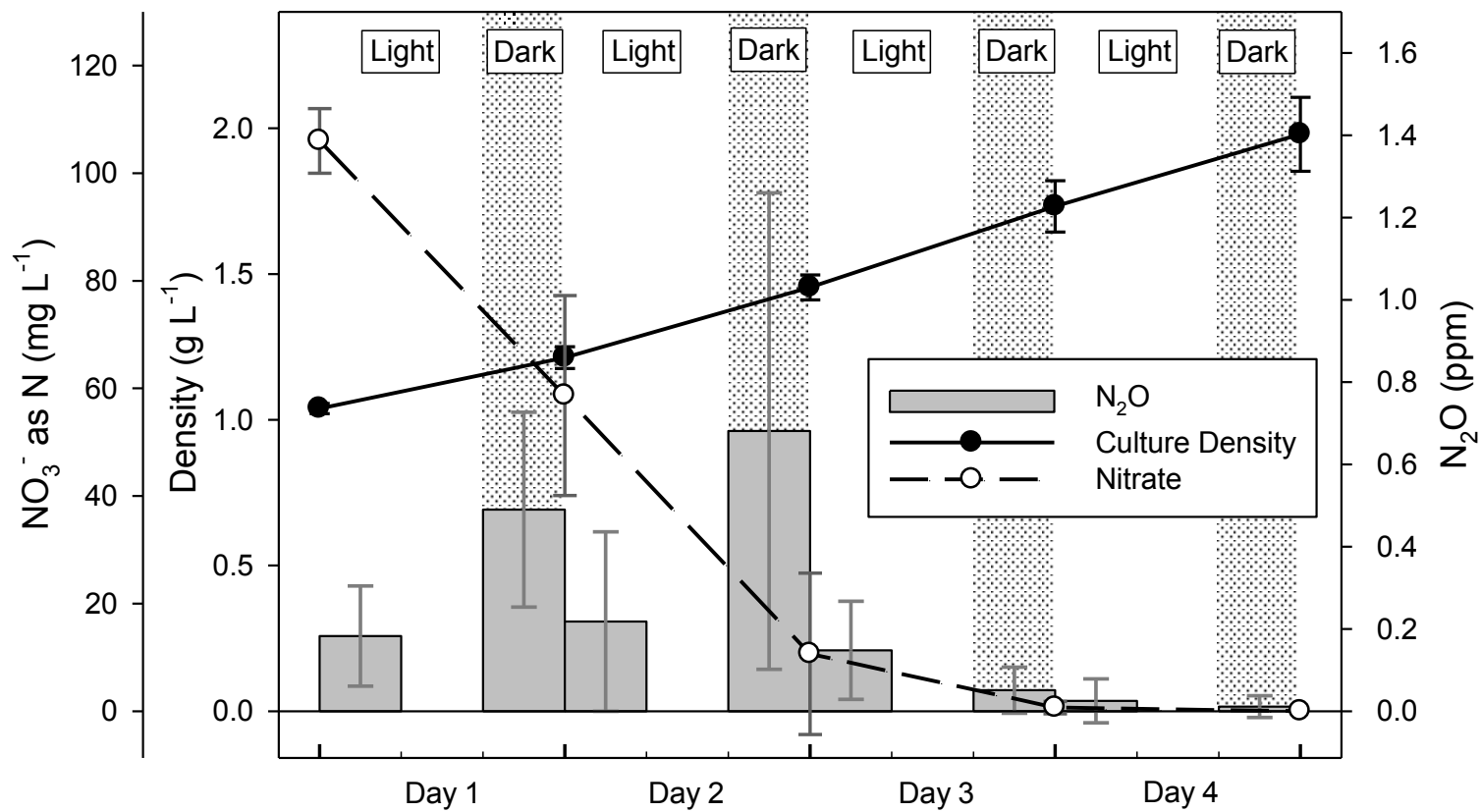

Figure 10: Average  $\text{N}_2\text{O}$  emissions, culture density, and nitrate (from nitrate fertilizer) in growth media for three replicates of the air-filled headspace. The width of the  $\text{N}_2\text{O}$  bar represents the headspace gas accumulation period. Error bars represent standard deviation ( $n=9$ ).

A two-tailed distribution, two-sample unequal variance Student's t test indicated that the N<sub>2</sub>O emissions for the light periods were significantly lower than the emissions for the dark periods when nitrate was present (P value of 0.0015). The cumulative N<sub>2</sub>O emissions for light periods with nitrate and dark periods with nitrate also show a statistically significant difference when compared to the periods without nitrate (P values of 0.0001 and 0.0000, respectively). There was no significant difference in total N<sub>2</sub>O production between the light and dark periods when no nitrate was present (P value of 0.306). The raw growth data, nitrate content, and N<sub>2</sub>O concentrations for the air headspace conditions are given below. Table 5 details the culture density for each of the three flasks for the three experimental runs. The OD measurements have been converted to g L<sup>-1</sup> using the previously determined correlation.

**Table 5: Raw culture density (g L<sup>-1</sup>) for the oxic conditions.**

Run #	Flask #	Day 1	Day 2	Day 3	Day 4	Day 5
1	1	1.05	1.25	1.49	1.85	2.20
	2	1.05	1.20	1.41	1.70	2.02
	3	1.05	1.24	1.43	1.74	2.02
2	1	1.05	1.25	1.50	1.75	1.96
	2	1.05	1.22	1.45	1.62	1.81
	3	1.05	1.23	1.45	1.63	1.83
3	1	1.02	1.23	1.52	1.88	2.12
	2	1.02	1.15	1.43	1.71	1.92
	3	1.02	1.16	1.40	1.70	1.93

The measured nitrate (NO<sub>3</sub><sup>-</sup> as N) concentrations from the first flask are shown in Table 6, below.

**Table 6: Raw nitrate (NO<sub>3</sub><sup>-</sup> as N) concentrations (mg L<sup>-1</sup>) for the air headspace conditions.**

Run #	Day 1	Day 2	Day 3	Day 4	Day 5
1	100	50	2	0	0
2	112	80	28	2	0
3	106	46	2	0	0

Table 7 gives the N<sub>2</sub>O concentration in the headspace of each flask for the three air headspace experimental runs. The FTIR peak area has been converted to ppm using the equation from the low concentration calibration curve (Figure 8).

**Table 7: Raw N<sub>2</sub>O concentration (ppm) for the oxic conditions**

Run	Flask	Day 1		Day 2		Day 3		Day 4		Day 5
		PM	AM	PM	AM	PM	AM	PM	AM	AM
1	1	0.32	0.77	0.53	0.88	0.04	0.04	0.04	0.02	0.00
	2	0.40	0.72	0.60	1.68	0.36	0.12	0.01	0.01	-0.02
	3	0.25	0.87	0.32	1.60	0.21	0.06	0.14	0.14	0.04
2	1	0.16	0.45	0.09	0.43	0.12	-0.01	0.00	0.00	0.01
	2	0.14	0.30	0.01	0.43	0.10	0.10	0.05	0.05	0.04
	3	0.19	0.45	0.18	0.34	0.06	0.13	0.03	0.03	0.02
3	1	0.03	0.24	0.08	0.17	-0.07	0.03	0.01	0.01	0.02
	2	0.10	0.30	0.10	0.21	0.03	-0.01	-0.05	-0.05	-0.03
	3	0.06	0.30	0.04	0.38	0.03	-0.01	-0.01	-0.01	0.02

## B. Nitrogen Headspace Conditions: Growth, Nitrate, and N<sub>2</sub>O Results

The experiment was repeated with a headspace filled with nitrogen gas to simulate PBR conditions. The microalgae growth rate, nitrate, and N<sub>2</sub>O emissions were monitored over the 4 day study with nitrogen gas purged into the headspace every 8

hours. Figure 11 shows the averaged data set for the nitrogen-filled headspace. As with the air headspace conditions, the average culture density is shown by the solid line, the average nitrate ( $\text{NO}_3^-$  as N) concentration is the dashed line, and the average  $\text{N}_2\text{O}$  concentration is shown by the grey bars with the error bars representing the standard deviation. Figure 11 shows that the average growth rate was nearly identical to that of the air headspace conditions at  $0.23 \text{ g L}^{-1}$ , and the nitrate was consumed in just over 3 days.

The  $\text{N}_2\text{O}$  emissions for the nitrogen headspace conditions exhibited a similar trend to that of the air headspace conditions but were several orders of magnitude higher. The trend of increased  $\text{N}_2\text{O}$  production over dark periods was also more pronounced in the nitrogen-filled headspace in comparison to the air-filled headspace. Cumulative  $\text{N}_2\text{O}$  emissions for the dark periods with nitrate present totaled  $2160.8 \text{ }\mu\text{g}$ , which is substantially higher than the  $11.4 \text{ }\mu\text{g}$  measured for the air-filled headspace under the same conditions. The cumulative  $\text{N}_2\text{O}$  emissions during the dark periods with nitrate were also much higher than those measured for the light periods with nitrate present, which totaled  $303.7 \text{ }\mu\text{g}$ . Once the nitrate was depleted, the  $\text{N}_2\text{O}$  concentrations dropped below the detection limit ( $-0.3 \text{ ppm} \pm 0.7 \text{ ppm}$ ). For the nitrogen-filled headspace, the total mass of  $\text{N}_2\text{O}$  produced from nitrate applied as fertilizer was calculated to be  $0.004 \text{ kg N}_2\text{O-N (kg N input)}^{-1}$  (or 0.4%), which is about half that of the  $0.01 \text{ kg N}_2\text{O-N (kg N input)}^{-1}$  IPCC standard used for terrestrial crops.<sup>18</sup> Further details are presented in Appendix A.

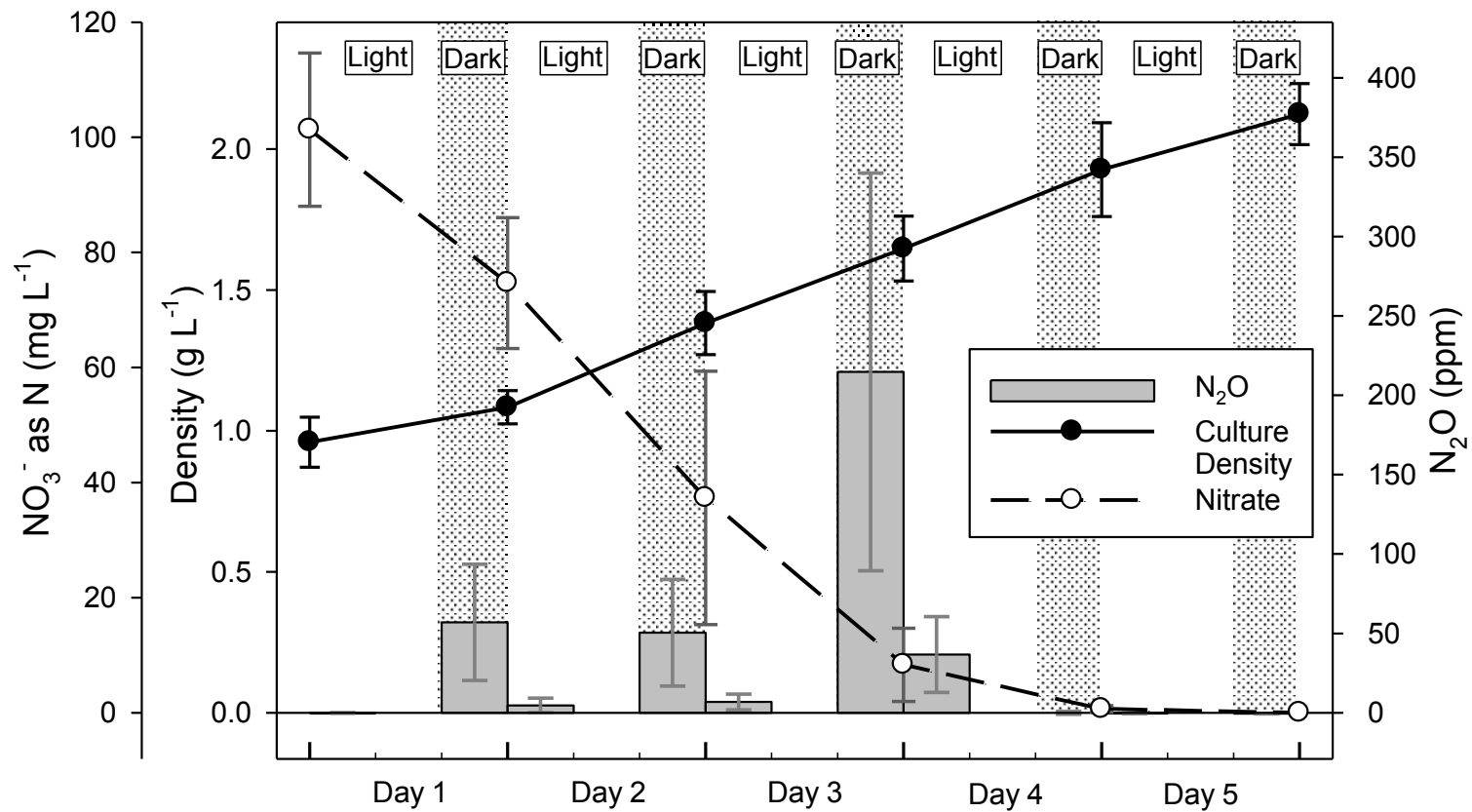

Figure 11: Average N<sub>2</sub>O emissions, culture density, and nitrate (from nitrate fertilizer) in growth media for three replicates of the nitrogen-filled headspace. The width of the N<sub>2</sub>O bar represents the headspace gas accumulation period. Error bars represent standard deviation (n=9).

A two-tailed distribution, two-sample unequal variance Student's t test shows that the cumulative N<sub>2</sub>O emissions for the light periods are significantly less than for the dark periods when nitrate is present in the growth media (P value of 0.0006). There is also a statistically significant difference in N<sub>2</sub>O production between the light periods with nitrate and the light periods without nitrate (P value of 0.0016), as well as for the dark periods with nitrate and dark periods without nitrate (P value of 0.0002). There was no significant difference in N<sub>2</sub>O production between the light and dark periods with no nitrate present (P value of 0.387).

The laboratory simulated well-mixed ORP (air-filled headspace) produced significantly less N<sub>2</sub>O than the simulated closed PBR (nitrogen-filled headspace) for both the light and dark periods when nitrate was present in the growth media, resulting in P values of 0.0023 and 0.0002, respectively. The results also show that once the nitrate is consumed, N<sub>2</sub>O emissions drop below detection limits, indicating that N<sub>2</sub>O production is the greatest for PBR's while nitrate is present. The experimentation was designed to represent the classic operation of a closed PBR and a well-mixed ORP. However, it is acknowledged that not all cultivation systems operate classically.

The raw growth data, nitrogen content, and N<sub>2</sub>O concentrations for the nitrogen headspace conditions are given below. Table 8 details the daily culture density for each of the three flasks for the three experimental runs. The OD measurements have been converted to g L<sup>-1</sup> using the previously determined correlation.



**Table 8: Raw culture density (g L<sup>-1</sup>) for the nitrogen headspace conditions.**

Run #	Flask #	Day 1	Day 2	Day 3	Day 4	Day 5
1	1	0.84	1.05	1.37	1.69	2.06
	2	0.84	1.05	1.37	1.64	1.96
	3	0.87	1.09	1.40	1.68	1.97
2	1	1.05	1.03	1.28	1.57	1.91
	2	1.05	1.03	1.25	1.50	1.83
	3	1.05	1.02	1.26	1.48	1.83
3	1	0.98	1.18	1.59	1.84	2.33
	2	0.98	1.15	1.47	1.68	2.10
	3	0.98	1.15	1.45	1.74	2.18

The measured nitrate concentrations from the first flask are given in Table 9, below.

**Table 9: Raw nitrate (NO<sub>3</sub><sup>-</sup> as N) concentrations (mg L<sup>-1</sup>) for the nitrogen headspace conditions.**

Run #	Day 1	Day 2	Day 3	Day 4	Day 5
1	116	84	52	12	1
2	90	78	48	12	1
3	98	62	12	1	0

Table 10 gives the N<sub>2</sub>O concentrations measured in the headspace of each flask over the three nitrogen headspace experimental runs. The FTIR peak area has been converted to ppm using the equation from the high concentration calibration curve (Figure 7).

**Table 10: Raw N<sub>2</sub>O concentrations (ppm) for the nitrogen headspace conditions. The blank cells were data points that had to be removed because of human or equipment error.**

Run	Flask	Day 1		Day 2		Day 3		Day 4		Day 5	
		PM	AM	PM	AM	PM	AM	PM	AM	PM	
1	1	-0.32	132.76	14.96			372.11	40.83	1.54	-0.09	
	2	0.22	59.65	7.97	45.96	6.84	286.81	63.52	1.17	-0.36	
	3	-0.05	62.66	13.06	56.39	14.96	238.82	54.61	0.82	-0.31	
2	1		66.16	4.27	53.96	5.15	80.16	7.89	-0.50	-0.23	
	2		75.67	5.78	62.27	4.84	95.74	16.85	-0.45	-0.52	
	3		26.92	1.82	110.56	9.41			-0.58	-0.44	
3	1	-0.28	15.87	1.73	5.06	0.92	-0.58	-0.67	-0.60		
	2	-0.21	59.47	4.01	7.08	0.78	-0.77	-0.58	-0.60		
	3	-0.17	13.31	1.48	62.31	11.66	-0.60	-0.56	-0.65		

## V. VERIFICATION OF N<sub>2</sub>O PRODUCTION ROUTE

Several experimental methods were performed in order to verify the hypothesis that N<sub>2</sub>O emissions are from the reduction of nitrate by denitrifying bacteria within the microalgal growth media. First, the DO concentrations in the microalgae cultures were monitored for both of the experimental headspace conditions since a low DO concentration indicates an anoxic environment in which denitrification could take place. Next, DNA analysis of the prokaryotic cells within the microalgal growth media was performed targeting the specific gene that encodes for nitric oxide reductase, the denitrifying enzyme which allows for the production of N<sub>2</sub>O. Lastly, antibiotics were applied to the microalgae cultures with the expectation that treated flasks should have a lower N<sub>2</sub>O concentration than untreated flasks if the hypothesis were true. The experimental results from these studies are detailed in the following sections.

### A. Dissolved Oxygen Concentrations

The experimental results indicate that a low culture oxygen level may lead to high N<sub>2</sub>O emissions; it was therefore hypothesized that the N<sub>2</sub>O emissions observed in these studies are a by-product of the anoxic bacterial denitrification pathway. To verify this hypothesis, the DO content for both the air and nitrogen headspace conditions was monitored over 24 hours; Figure 12 shows that the air headspace maintained an oxygen rich environment for the entirety of the experiment, with the lowest oxygen concentration

of  $4.26 \text{ mg L}^{-1}$  occurring at the end of the dark period, while the nitrogen headspace experienced partially anoxic conditions. During the light periods of the nitrogen headspace study, the microalgae cultures maintained oxic conditions. This is explained by the fact that during the light periods, the microalgae is photosynthetically active and producing oxygen, but over the dark periods the microalgae are respiring and consuming oxygen.<sup>51, 52</sup> It can be seen that when the lights are turned off, the DO concentration for the nitrogen-filled headspace decreases rapidly to  $0 \text{ mg L}^{-1}$  and the culture remains anoxic for the remainder of the dark period. Previous studies have reported that maintaining an oxygen level of greater than 0.2 ppm will inhibit the reduction of nitrate by some species of bacteria, indicating that bacterial denitrification is possible over the dark periods of the nitrogen-filled headspace.<sup>51</sup> This result can be seen in Figure 12 with the limit for denitrification (shown by the dotted line) clearly above the DO of the nitrogen-filled headspace, indicating that the microalgae cultures are within the range of possible denitrification for the majority of the dark period.

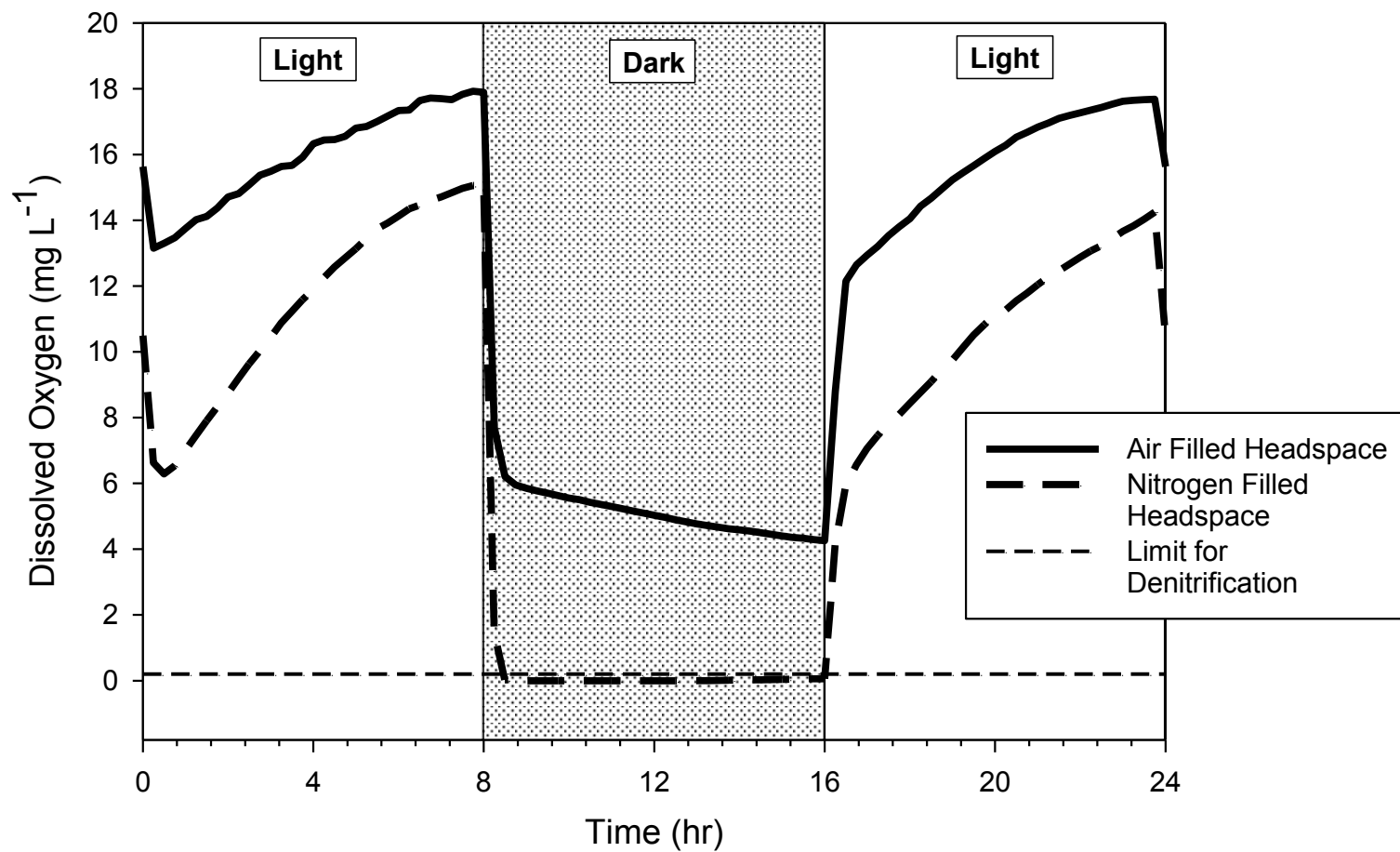

Figure 12: Dissolved oxygen concentrations over 24 hours for the oxic conditions (solid line) and anoxic conditions (dashed line) with a five minute gas purge every eight hours. The upper limit for anoxic denitrification (0.2 ppm) is shown as the thin dashed line.<sup>51</sup>

The DO concentration measurements for the nitrogen-filled headspace show that the culture becomes anoxic at the same time that the N<sub>2</sub>O emissions peak, supporting the hypothesis that the N<sub>2</sub>O production is from denitrifying bacteria present in the culture media. However, N<sub>2</sub>O emissions were still observed under oxic conditions. It is possible that N<sub>2</sub>O detected during oxic periods may have been a carryover effect of dissolved N<sub>2</sub>O generated during the anoxic dark period transferring to the gas phase during the following light period. This explanation may account for the elevated N<sub>2</sub>O emissions observed over the oxic light period on the fourth day of the nitrogen-filled headspace run (Figure 11). Also, denitrification can occur at bulk liquid DO levels above 0.2 ppm if bacteria form flocs or exist in biofilms where oxygen transport limitations allow bacteria to experience lower DO than in the surrounding bulk liquid. This may be an explanation for the N<sub>2</sub>O emissions observed at the higher DO levels of the light periods.

To further test the denitrifying bacteria hypothesis, the microalgae cultures were grown in the presence of antibiotics and tests were performed to detect bacterial genes involved in N<sub>2</sub>O production. These results are detailed in the following sections.

## B. Detection of Genes Involved in N<sub>2</sub>O Production

To investigate the hypothesis that denitrifying bacteria are producing the N<sub>2</sub>O emissions, DNA extraction and PCR amplification of the bacterial denitrifying gene *norB*, encoding for the enzyme involved in N<sub>2</sub>O production, were performed. The denitrification pathway reduces nitrate (NO<sub>3</sub><sup>-</sup>) to nitrogen gas through a multi-step process, and N<sub>2</sub>O is an intermediate in this pathway that is produced by reduction of NO

to N<sub>2</sub>O. This step is catalyzed by nitric oxide reductase, which is encoded by the *nor* gene.<sup>27, 33-35</sup> Therefore, to investigate the hypothesis that denitrifying bacteria are producing N<sub>2</sub>O emissions, PCR assays were used to determine if the *norB* gene was present in the microalgal culture media under investigation.

Figure 13 shows the PCR results. Using the known DNA ladder as a standard, the bands of amplified DNA were compared with the expected amplicon size (bp) of the *norB* genes. For ease of viewing, the bp corresponding to each *norB* gene has been labeled with an arrow and the DNA ladder reference has been included on the left side of the image. The first column is the DNA ladder, followed by the amplification of the *norB* primer (670 bp), the *qnorB* primer (262 bp) and lastly the *cnorB* primer (389 bp). The *norB* and *qnorB* primers have an extra band that can best be explained by the primers amplifying a gene other than the *norB* genes that were targeted. It is important to note that the DNA extraction was not specific and was performed on any microbe smaller than 1.2 micrometers. Also, the PCR amplification was performed on the entire DNA extracted, meaning that the extra bands could be amplifying a genetic sequence from a different microbe that shares a similar genetic sequence as the primers. This conclusion can be made by looking at the expected size of the gene, and the much larger size of the unidentified band. The *cnorB* gene has a less concrete result with the band appearing lighter than the other two and seeming to be closer to the 200 bp standard than expected. A PCR amplification of the *norB* gene was also performed at 35 cycles and was positively detected with no unidentified bands. It is also worth noting that prior to analysis of the *nor* gene, a PCR assay of the same DNA extract was performed with

primers for the prokaryotic 16s gene to verify the presence of bacteria in the microalgae culture.

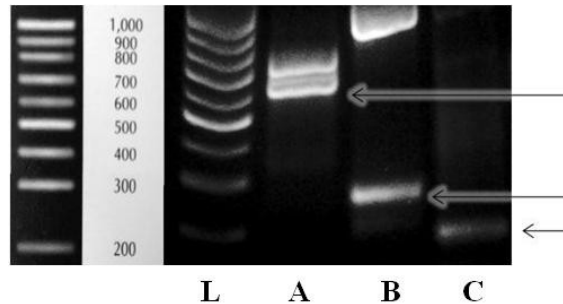

**Figure 13:** PCR results visualized under UV in a 1% agarose gel. The standard DNA ladder is in the first column (labeled L), followed by the PCR amplifications of the *norB* (A), *qnorB* (B), and *cnorB* (C) genes. The bands of the expected size are indicated by the arrows.

However, the results from the three primers and two PCR assays are concrete enough to say that the denitrifying gene *norB* is present in the microbial DNA extracted from the microalgae cultures. This analysis of the microalgal media confirms that the *norB* gene was detected, indicating that denitrifying bacteria with the ability to reduce NO to N<sub>2</sub>O were present in the culture.

### C. Antibiotic Cultivation Results

The N<sub>2</sub>O production of the microalgae cultures was monitored with the addition of antibiotics to the culture media. Broad spectrum antibiotics are known to inhibit the growth of bacteria, and it has been shown that the combination of penicillin g and streptomycin antibiotics will effectively kill both gram-positive and gram-negative bacteria while having a minimal effect on the microalgae cultures.<sup>41</sup> However, it is highly unlikely that one antibiotic treatment will kill all of the bacteria as some may be



resistant to the antibiotics used. To determine whether inactivating bacteria present would lead to a reduction in N<sub>2</sub>O production, these broad spectrum antibiotics were added to the microalgae culture media and N<sub>2</sub>O concentrations were measured in the headspace gases using the same nitrogen headspace test protocol described above. Two of the three cultivation flasks were treated with the broad spectrum antibiotics, while the third served as a control and N<sub>2</sub>O concentrations were measured during the dark (anoxic) periods. The anoxic periods were chosen since the N<sub>2</sub>O emissions were highest and the effects of the antibiotics would be most pronounced under these conditions. The microalgal growth rate and nitrate depletion rate were consistent between the cultures treated with antibiotics and control cultures without antibiotics and the rates were also comparable to the previous experimental runs. The N<sub>2</sub>O production in the antibiotic treated flasks was significantly less than that of the untreated flask with an average N<sub>2</sub>O reduction of 78.9% over the four day experiment as can be seen in Table 11.

**Table 11: N<sub>2</sub>O concentrations of antibiotic treated microalgae cultures and percent reduction in N<sub>2</sub>O emissions over a four day growth period.**

	Day 1	Day 2	Day 3	Day 4
Treated Flask 1 (ppm)	25.6	10.4	28.3	0.4
Treated Flask 2 (ppm)	24.2	14.0	22.1	0.7
Untreated Flask (ppm)	50.0	95.2	137.9	12.3
Average N <sub>2</sub> O Reduction	51.2%	87.2%	81.7%	95.5%

Figure 14 shows a graphical representation of the N<sub>2</sub>O emissions for the antibiotic treatment study. A complete reduction in N<sub>2</sub>O emissions was not expected since the antibiotics take time to inhibit growth of the bacteria and some bacterial strains may have

been resistant to the antibiotics used. However, these results strongly support the hypothesis that  $N_2O$  production by denitrifying bacteria is a major contributor, if not the only contributor, to  $N_2O$  production in microalgae cultures.

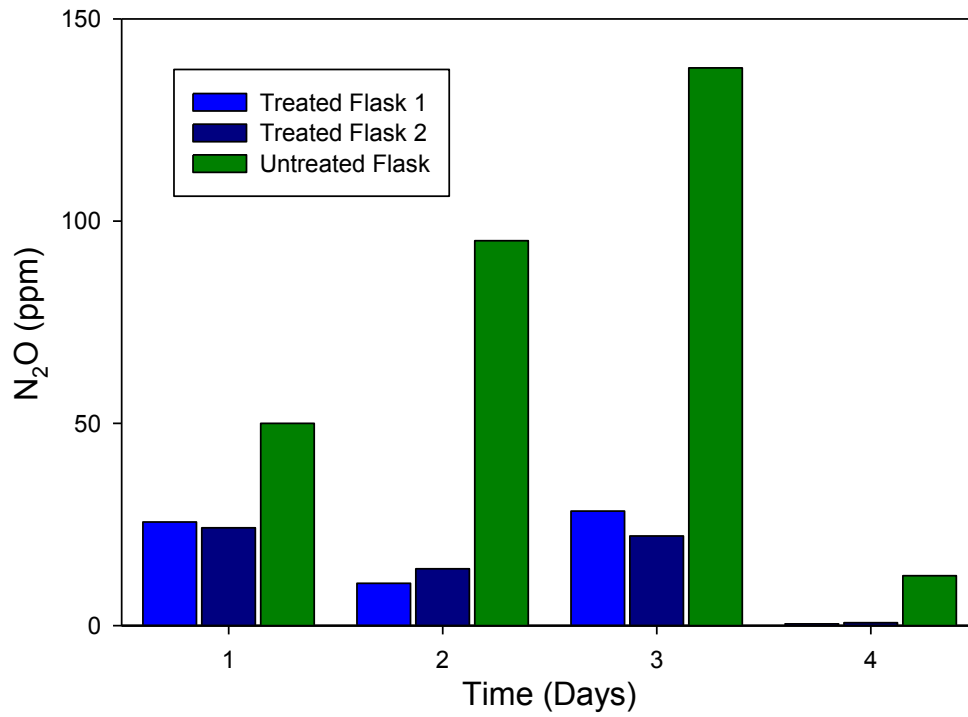

Figure 14:  $N_2O$  concentrations from the anoxic periods of antibiotic treated microalgae cultures over a four day growth period.

## VI. ENVIRONMENTAL IMPACTS, CONTROL TECHNIQUES, AND LCA IMPLICATIONS

To consider the large scale impact of these N<sub>2</sub>O results, both the air and nitrogen headspace experimental conditions were compared to PBR and ORP full scale microalgae cultivation systems. It was determined that, for comparison purposes, the air headspace conditions (oxic culture) could be representative of either growth system. An ORP could be modeled using the results from the air headspace conditions if it was thoroughly mixed through the night to facilitate culture access to oxygen. It could also represent a closed PBR continually sparged with air or a 2% CO<sub>2</sub> air mixture to maintain an oxic environment.

Similarly, the nitrogen headspace conditions (partially anoxic culture) could be representative of either a PBR or ORP system. A PBR with no or very little headspace above the microalgae, and the sparge system idle at night, would not have any source of oxygen and could be modeled using the results of the nitrogen headspace conditions. Also, it is feasible that certain areas throughout an ORP would never come in contact with the air, such as an area of sludge on the bottom of the pond, and the anoxic culture of the nitrogen headspace would more accurately represent these areas. However, an unmixed ORP would be a combination of both headspace conditions and, depending on the DO concentrations of the actual large-scale system, may be modeled using the results from both headspace conditions. While keeping in mind these comparisons, large-scale

N<sub>2</sub>O emissions were calculated for both the air and nitrogen headspace conditions, and several control techniques were proposed as detailed in the following sections.

#### A. Large Scale N<sub>2</sub>O Emissions

The LCA done by Batan et al. indicates that an increase in GHG emissions of 0.392 g CO<sub>2</sub>-eq MJ<sup>-1</sup> would have a 1% impact on the overall life cycle GHG emissions.<sup>11</sup> This 1% impact was chosen to correspond to the minimum GHG contribution that would have a significant impact on the overall LCA. The N<sub>2</sub>O mole fraction per flask per 8 hr sample period that corresponds to this 1% impact level was calculated to be 1.34 ppm in the headspace of the experimental system presented herein. Repeating these calculations with the N<sub>2</sub>O mole fractions measured in this study over a five day growth period, the air-filled headspace (simulated ORP conditions) results suggest a modest net GHG emissions increase of 0.149% due to N<sub>2</sub>O production. However, for the nitrogen-filled headspace (simulated PBR conditions), over the same five day growth period, direct N<sub>2</sub>O emissions from cultivation would dramatically increase the net GHG emissions by 16.6%. If the maximum N<sub>2</sub>O concentrations observed in this study (372 ppm) were applied to these calculations, the resulting life cycle GHG emissions would increase by 74.5%, rendering microalgae ineffectual as a feedstock for advanced biofuels based on DOE environmental goals. Details on the calculation can be found in Appendix A.

The N<sub>2</sub>O concentrations observed with the air headspace conditions can be applied to an open pond growth system with a depth of 15 cm, and a growth cycle of 5 days with the nitrate depleted within three days. Scaling up the N<sub>2</sub>O emissions observed

in the entirely oxic air headspace conditions resulted in 0.685 kg N<sub>2</sub>O hectare<sup>-1</sup> yr<sup>-1</sup>. However, if anoxic culture conditions exist (nitrogen headspace), then the N<sub>2</sub>O emissions result in approximately 79.4 kg hectare<sup>-1</sup> yr<sup>-1</sup> of N<sub>2</sub>O released into the atmosphere, a drastic increase from the oxic culture conditions. The scaled up N<sub>2</sub>O emissions and equivalent CO<sub>2</sub> emissions are presented in Table 12 along with the average N<sub>2</sub>O concentrations used in the calculations. Further details on how these calculations were performed can be seen in Appendix A.

**Table 12: N<sub>2</sub>O emissions scaled up for a year, assuming the nitrogen is used in 3 days, the growth cycle is 5 days, and volume is based on an open pond depth of 15 cm.**

	N <sub>2</sub> O Observed Dark (ppm)	N <sub>2</sub> O Observed Light (ppm)	N <sub>2</sub> O Emissions (kg ha <sup>-1</sup> yr <sup>-1</sup> )	% of Nitrogen converted to N <sub>2</sub> O
Oxic Conditions	0.585	0.187	0.685	0.004%
Anoxic Conditions	90.4	10.4	79.4	0.439%
Maximum Observed	372	63.5	356	1.97%

## B. Conditions and Control Techniques for N<sub>2</sub>O Production

The results of this study indicate that microalgae cultures produce significant levels of N<sub>2</sub>O under anoxic conditions in the presence of nitrate. In the microalgae growth stage, nitrate is supplied in the form of dissolved fertilizer at the beginning of the batch growth process. The uptake rate of nitrogen by the microalgae is a light dependent process and nitrate was depleted within three days.<sup>12, 53, 54</sup> During photosynthetic active

periods the microalgae produce oxygen and therefore grow in an oxic environment.<sup>51</sup> Accordingly, there is a small window in the microalgae cultivation process for the production of N<sub>2</sub>O by denitrifying bacteria. This window consists of the first few dark periods after inoculation of the culture when nitrate is present in the growth media and anoxic conditions exist.

Direct N<sub>2</sub>O emissions can be eliminated by understanding the mechanism for the formation of N<sub>2</sub>O from nitrogen based fertilizers and by creating an environment where the reduction of nitrate to N<sub>2</sub>O is not favorable during the cultivation of microalgae. Several possible methods for controlling N<sub>2</sub>O production exist. Steps could be taken to prevent bacterial contamination in microalgae cultures to effectively remove the pathway for N<sub>2</sub>O production. However, it would be impractical to maintain axenic cultures in a large scale cultivation system due to the risk of contamination, high cost of antibiotics, and potential for antibiotics to reduce microalgae growth rates.<sup>41</sup> Maintaining a DO level during the dark periods of greater than 0.2 ppm has been reported to inhibit the reduction of nitrogen by some bacteria by inhibiting the production or activity of enzymes involved in denitrification.<sup>38, 55</sup> An oxygen level well above this threshold can be achieved by cultivating under 24 hour light, sparging air through the culture, or maintaining an oxygen rich headspace while mixing the culture. To maintain the oxygen level in a PBR, it is assumed that the sparge system could be operated at night to generate an oxic environment while nitrate is present, thereby eliminating the potential for denitrification and the production of N<sub>2</sub>O. In the case of controlling emissions for an ORP growth system, there are challenges present such as environmental contamination with denitrifying bacteria, and development of anoxic regions due to incomplete mixing and a

buildup of sludge and decaying material at the bottom of the pond. Therefore, to ensure minimal N<sub>2</sub>O emissions, an ORP must be thoroughly mixed at night to maintain an entirely oxic environment.

### C. Implications for LCA Evaluations

Based on the data presented in this study, future microalgae LCAs must consider the potential for direct N<sub>2</sub>O emissions from the cultivation stage. Direct N<sub>2</sub>O emissions can be included in the LCA, which will effectively increase the GHGs; this is the only option for an ORP that does not thoroughly mix the microalgae culture. Alternatively, the energy required to fully mix an ORP or sparge PBR's with air at night could be included, as in Batan et al.<sup>11</sup> Based on the results from this study, the recommended N<sub>2</sub>O emissions to be included in future LCA's are 0.003% of the nitrogen fertilizer applied to a fully oxic culture (such as a well mixed ORP or PBR sparged with air) and 0.4% for a microalgae culture that will be anoxic during the dark periods (including a closed PBR with no sparging), a considerable difference from the 1% IPCC standard used for the direct N<sub>2</sub>O emissions from terrestrial crops.

## VII. CONCLUSION AND FUTURE WORK

This thesis aimed to investigate the direct N<sub>2</sub>O emissions from the cultivation of microalgae through experimentation. Several questions were posed based on the lack of accurate information on the N<sub>2</sub>O emissions from microalgae cultivation. These questions included how much N<sub>2</sub>O was emitted from microalgae cultivation and how the direct N<sub>2</sub>O emissions from microalgae differ from those of terrestrial crops, as well as what the N<sub>2</sub>O production route is. The environmental GHG impacts and implications for LCA, including possible control mechanisms, were also a consideration for this work.

Through bench-scale experimentation, the direct N<sub>2</sub>O emissions from microalgae cultures grown under oxic and anoxic conditions were quantified with an FTIR. These studies revealed that N<sub>2</sub>O production was amplified by an anoxic environment while nitrate was present in the growth media. Calculations showed that for entirely oxic microalgae culture conditions (i.e. well mixed ORP or aerated PBR), 0.003% of the total nitrogen applied to the system as fertilizer was converted to N<sub>2</sub>O, and 0.4% of the total nitrogen was converted for the partially anoxic culture conditions (closed PBR). Both of these values are below the 1% IPCC standard for terrestrial crops but the N<sub>2</sub>O emissions from an anoxic environment are still noteworthy.<sup>18</sup>

By scaling up the N<sub>2</sub>O emissions quantified from the anoxic nitrogen headspace conditions it can be seen that a microalgae cultivation system with a depth of 15 cm and a batch growth cycle of 5 days would release 79.4 kg hectare<sup>-1</sup> year<sup>-1</sup> of N<sub>2</sub>O into the



atmosphere. Based on the 298 CO<sub>2</sub>-eq global warming potential of N<sub>2</sub>O, these N<sub>2</sub>O emissions are the equivalent of 23,700 kg CO<sub>2</sub> hectare<sup>-1</sup> year<sup>-1</sup>. When applying these values to the LCA done by Batan et al., the N<sub>2</sub>O emissions from the cultivation stage of microalgae amount to a GHG increase of 16.6 %. In order to see the potential environmental benefits of microalgae that have been previously published these GHG emissions would need to be mitigated by implementing control methods.

It was found that anoxic denitrification from bacteria is the most likely cause of N<sub>2</sub>O production based on the DO data, the antibiotic treatment study, and the DNA analysis performed. While this conclusion was not proven to 100% certainty, there is strong evidence indicating that anoxic denitrification is the primary source of the N<sub>2</sub>O emissions observed. With this information, it was possible to propose several methods to control N<sub>2</sub>O emissions. In the case of a PBR, a continuous sparging of air or a CO<sub>2</sub> and air mixture would ensure an oxygen rich environment and therefore prohibit the production of N<sub>2</sub>O with a relatively minimal energy input. The control method for an ORP is to ensure complete mixing of the culture to minimize any anoxic regions that may be present. However, this control method would require a model of the ORP's DO concentrations to ensure that the culture was maintaining an oxic environment.

While this study made some profound conclusions about the direct N<sub>2</sub>O emissions from microalgae cultivation, it leaves room for future work. First, it would be beneficial to further verify that denitrification is the sole source of N<sub>2</sub>O production. Florez-Leiva et al. hypothesized that the N<sub>2</sub>O emissions seen in their ORP were by-products of oxic NH<sub>4</sub> oxidation or bacterial nitrification, which is shown in Figure 15.<sup>17</sup> Since modest N<sub>2</sub>O emissions were observed during the light (oxic) periods of the anoxic headspace

conditions, it would be necessary to rule out the nitrification pathway before concluding that denitrification was the sole N<sub>2</sub>O production route. This could be done through similar PCR techniques as the ones performed for the denitrifying *norB* gene.

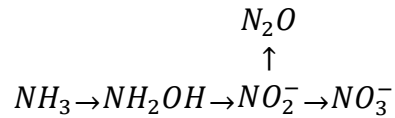

**Figure 15: The nitrification pathway with N<sub>2</sub>O as a by-product.**

Another important step before concluding that denitrification is the sole production mechanism would be further DNA and RNA analysis to confirm the denitrification pathway. This would include a quantitative polymerase chain reaction (qPCR) and RNA analysis of the *norB* gene to verify that the *norB* gene is active and producing the nitric oxide reductase enzyme required to produce N<sub>2</sub>O. These techniques could also be extended to other genes in the denitrifying pathway including *nosZ*, which encodes for nitrous oxide reductase and is responsible for the production of N<sub>2</sub> from N<sub>2</sub>O. Looking into this gene would be an important step as it provides a sink for N<sub>2</sub>O and a lack of its presence would indicate that the denitrification pathway is truncated and the N<sub>2</sub>O produced could not be converted to N<sub>2</sub>.

It would also be beneficial to further research the impact that DO has on the N<sub>2</sub>O emissions. The DO concentration at which denitrification can no longer occur varies depending on the type of denitrifying bacteria present.<sup>56</sup> This thesis has shown that a completely anoxic culture produces high quantities of N<sub>2</sub>O while a fully oxic environment does not, but a DO limit where denitrification will occur has yet to be

determined. Also, a model of the DO concentrations found in a full scale ORP could be beneficial to further understand the possible N<sub>2</sub>O emissions. Other factors could also be researched including the effects of the nitrogen source (nitrate or urea) or other trace metal concentrations on N<sub>2</sub>O production.

While N<sub>2</sub>O emissions are important to research for the high global warming potential, there are many other gaseous species that could prove to be just as harmful to the environment and human health if emitted from microalgae cultures. Dr. Pinar Omur-Ozbek in the Civil and Environmental Engineering Department of Colorado State University has shown that a variety of volatile organic compounds (VOC) are present in the wastewater outputs from microalgae cultivation at Solix BioSystems. Using gas chromatography, hexanal, heptanal, decanal, 1-octen-3-ol, 1-pentanol, phenol, hexane, heptane, nonane, carbamic acid, and butanoic acid were positively identified in the wastewater. This is concerning as VOC's are included in the Clean Air Act and some of the health concerns associated with VOC's are nausea, dizziness, eye irritation, fatigue, headache, and even cancer through long term exposure. While these compounds were found in the wastewater, it is yet unknown how many of them or at what concentrations would be emitted from the microalgae cultivation. It would also be beneficial to look for methane (CH<sub>4</sub>), as well as other alcohols, aldehydes, ketones, alkanes, and fatty acids. Quantifying the direct emissions of these VOC's and other species is a critical next step for evaluating the efficacy of microalgae-based biofuels.

This thesis has aimed to provide a deeper look into the direct N<sub>2</sub>O emissions from cultivation since microalgae based biofuels are being critically evaluated by LCA and could have a significant impact on meeting alternative transportation fuel goals.

However, N<sub>2</sub>O emissions from microalgae cultivation could have a substantial impact on the overall environmental assessment of the microalgae to biofuels process. By quantifying the direct N<sub>2</sub>O emissions from the cultivation of microalgae, N<sub>2</sub>O has been shown to be a critical GHG emission needing to be accounted for in future LCA of microalgae based biofuels. In this study, cultivation techniques were used to create oxic and anoxic culture environments with N<sub>2</sub>O emissions quantified utilizing FTIR spectrometry. For the partially anoxic environment of the nitrogen headspace condition, N<sub>2</sub>O emissions were elevated during dark periods and minimal during light periods, while the N<sub>2</sub>O emissions from the oxic environment of the air headspace condition resulted in negligible emissions for both the dark and light periods.

Experimental results showed that N<sub>2</sub>O production was stimulated by anoxic conditions when nitrate was present in the growth media, indicating that the production of N<sub>2</sub>O was due to denitrifying bacteria. The presence of denitrifying bacteria was also determined experimentally through PCR amplification of the denitrifying gene *norB*, further indicating that the N<sub>2</sub>O emissions observed are a by-product of the denitrification pathway. The reduction in N<sub>2</sub>O production with the introduction of broad spread antibiotics was further support for the hypothesis that N<sub>2</sub>O production by denitrifying bacteria is a major contributor, if not the only contributor, to N<sub>2</sub>O production in microalgae cultures. It was also shown that the direct N<sub>2</sub>O emissions from microalgae have the GHG potential to make microalgae ineffectual as an advanced feedstock unless controlled. The results of this thesis have shown that through a detailed understanding of the microalgae growth system and simple control techniques, N<sub>2</sub>O emissions can be

minimized; continuing to support the GHG emissions benefits of microalgae that have been previously publicized.

## VIII. APPENDIX

### A. Scaling Calculations and Equations

#### *1. Theoretical Flask Concentrations using the IPCC 1% Standard*

The IPCC standard for terrestrial crop N<sub>2</sub>O emissions utilizes the "emission factor for N<sub>2</sub>O emissions from N inputs" of 0.01 kg N<sub>2</sub>O–N (kg N input)<sup>-1</sup>. This IPCC standard that 1% of all nitrogen applied as fertilizer to terrestrial crops was used to estimate the concentrations of N<sub>2</sub>O that would be expected in the flasks for the experimental system described. These calculations were done in order to estimate an expected order of magnitude which was used to help set up for N<sub>2</sub>O analysis. To make these calculations the following assumptions were made:

1. 0.638 gm NaNO<sub>3</sub> L<sup>-1</sup> resulting in 105 mg N L<sup>-1</sup> is supplied at inoculation
2. A flask volume of 1.1 L with a culture volume of 0.5 L and a gas volume of 0.6 L
3. A batch growth time of 7 days with an 8 hour headspace accumulation period between sampling
4. The 1% IPCC emission factor is appropriate for microalgae
5. The N<sub>2</sub>O emissions remain constant over the growth period

The moles of N<sub>2</sub>O were calculated using the following equation:

$$n_{N_2O} = \frac{C_{NaNO_3} * V_c * EF_1}{2 * MW_{NaNO_3}}$$

with  $n_{N_2O}$  = the moles of  $N_2O$ ,  $C_{NaNO_3}$  = the concentration of  $NaNO_3$  in  $g L^{-1}$ ,  $V_c$  = the culture volume,  $EF_1$  = the IPCC 1% environmental factor, and  $MW_{NaNO_3}$  = the molecular weight of  $NaNO_3$ . Next the number of moles of gas was found using:

$$n_g = \frac{P_{amb} * V_g}{R_g * T_{amb}}$$

with  $n_g$  = the moles of gas,  $P_{amb}$  = the ambient pressure,  $V_g$  = the volume of gas,  $R_g$  = the universal gas constant,  $T_{amb}$  = the ambient temperature. Once these values were known, the estimated concentration of  $N_2O$  in each flask could be calculated using:

$$C_{N_2O} = \frac{n_{N_2O}}{n_g * \frac{t_b}{t_s}} * 10^6$$

with  $C_{N_2O}$  = the concentration of  $N_2O$  in ppm,  $t_b$  = the batch growth time,  $t_s$  = accumulation time between samples. Using the appropriate unit conversions and these equations with the given assumptions, an expected concentration of  $N_2O$  for a given flask was calculated to be 36.2 ppm.

## 2. Scaling $N_2O$ Emissions Assuming Open Pond Dimensions

The  $N_2O$  concentrations observed in this study were scaled up using the dimensions of an open pond growth system. The mass of  $N_2O$  that would be emitted as

well as the percent of nitrogen from the fertilizer that was converted to N<sub>2</sub>O were calculated with the following assumptions:

1. A batch growth time of 5 days with nitrate consumed in 3 days
2. A culture volume based on an open pond depth of 15 cm
3. N<sub>2</sub>O emissions are different for day and night, but remain constant while nitrate is present
4. Flask volume of 1.1 L with 0.5 L culture and 0.6 L of gas
5. A nitrogen concentration of 105 mg/L at inoculation of each batch growth cycle

The moles of gas were first found using:

$$n_g = \frac{P_{amb} * V_g}{R_g * T_{amb}}$$

with  $n_g$  = the moles of gas,  $P_{amb}$  = the ambient pressure,  $V_g$  = the volume of gas,  $R_g$  = the universal gas constant,  $T_{amb}$  = the ambient temperature. Next the moles of N<sub>2</sub>O were calculated using:

$$n_{N_2O} = \frac{(C_{N_2O.d} + 2 * C_{N_2O.l}) * n_g}{10^6}$$

with  $n_{N_2O}$  = the moles of N<sub>2</sub>O,  $C_{N_2O.d}$  = concentration of N<sub>2</sub>O observed over the dark period in ppm, and  $C_{N_2O.l}$  = concentration of N<sub>2</sub>O observed over the light period in ppm.

The mass of N<sub>2</sub>O that would be released into the atmosphere could then be calculated using:



$$M_{N_2O} = t_N * \frac{n_{N_2O} * MW_{N_2O}}{V_c} * \frac{365}{t_b} * D_p$$

with  $M_{N_2O}$  = Mass of N<sub>2</sub>O emitted in kg ha<sup>-1</sup> yr<sup>-1</sup>,  $t_N$  = the time with nitrate,  $MW_{N_2O}$  = the molecular weight of N<sub>2</sub>O,  $t_b$  = the batch growth time, and  $D_p$  = depth of the open pond.

Applying the appropriate unit conversions and average N<sub>2</sub>O emissions from the oxic conditions to this equation resulted in 0.685 kg N<sub>2</sub>O hectare<sup>-1</sup> yr<sup>-1</sup> while the values from anoxic conditions resulted in 79.4 kg hectare<sup>-1</sup> yr<sup>-1</sup> and the maximum concentrations observed resulted in 356 kg N<sub>2</sub>O hectare<sup>-1</sup> yr<sup>-1</sup>.

In order to find the percent of nitrogen that would be converted to N<sub>2</sub>O the total mass of nitrogen from the fertilizer was calculated using:

$$M_{N.f} = \frac{C_{NaNO_3}}{MW_{NaNO_3}} * MW_N * \frac{365}{t_b} * D_p$$

with  $M_{N.f}$  = mass of nitrogen applied as fertilizer in a year,  $MW_{NaNO_3}$  = molecular weight of NaNO<sub>3</sub>,  $MW_N$  = molecular weight of N,  $t_b$  = the batch growth time, and  $D_p$  = depth of the open pond. Next the mass of nitrogen from the N<sub>2</sub>O emitted was calculated using:

$$M_{N.N_2O} = M_{N_2O} * \frac{2 * MW_N}{MW_{N_2O}}$$

with  $M_{N.N_2O}$  = mass of the nitrogen from N<sub>2</sub>O emitted in kg ha<sup>-1</sup> yr<sup>-1</sup>. The percent of nitrogen lost to N<sub>2</sub>O could then be calculated using:

$$\%N_{N_2O} = \frac{M_{N.N_2O}}{M_{N.f}} * 100$$

with  $\%N_{N_2O}$  = the percent of nitrogen from fertilizer that was converted to  $N_2O$ .

Continuing the calculations of the emissions from the oxic environment resulted in 0.004%, with the anoxic conditions resulting in 0.439% and the maximum values observed resulting in 1.97%. These calculations for the percent of nitrogen converted to  $N_2O$  for the oxic and anoxic conditions result in similar values as those obtained using the actual experimental data.

### *3. Conversions from $N_2O$ Flask Concentrations to Mass of $N_2O$ and Percent of Nitrogen Converted to $N_2O$*

The  $N_2O$  concentrations analyzed in this study were converted to a mass in order to present the mass of  $N_2O$  emitted for the dark periods and the mass emitted for the light periods. These masses were also totaled for each scaled representation and used to calculate the percent of nitrogen converted to  $N_2O$  as a comparison to the IPCC standards for terrestrial crops. These calculations were achieved using the assumption of a flask volume of 1.1 L, culture volume of 0.5 L, and gas volume of 0.6 L.

The moles of gas were found using:

$$n_g = \frac{P_{amb} * V_g}{R_g * T_{amb}}$$

with  $n_g$  = the moles of gas,  $P_{amb}$  = the ambient pressure,  $V_g$  = the volume of gas,  $R_g$  = the universal gas constant,  $T_{amb}$  = the ambient temperature. Next the moles of  $N_2O$  were calculated using:

$$n_{N_2O} = \frac{C_{N_2O} * n_g}{10^6}$$

with  $n_{N_2O}$  = the moles of N<sub>2</sub>O, and  $C_{N_2O}$  = concentration of N<sub>2</sub>O observed in ppm. The mass of N<sub>2</sub>O emitted from each flask could then be calculated using:

$$M_{N_2O} = n_{N_2O} * MW_{N_2O}$$

with  $M_{N_2O}$  = the mass of N<sub>2</sub>O emitted in g and  $MW_{N_2O}$  = the molecular weight of N<sub>2</sub>O.

To find the percent of nitrogen converted to N<sub>2</sub>O the mass of nitrogen in the N<sub>2</sub>O emissions was calculated using:

$$M_{N-converted} = M_{N_2O} * \frac{2 * MW_N}{MW_{N_2O}}$$

with  $M_{N-converted}$  = the mass of nitrogen converted to N<sub>2</sub>O in g and  $MW_N$  = the molecular weight of nitrogen. The total mass of nitrogen supplied to the system was then found using:

$$M_N = \frac{N_A * V_T}{10^3}$$

with  $M_N$  = the total mass of nitrogen supplied as fertilizer in g,  $N_A$  = the nitrogen measured in the assay in mg L<sup>-1</sup>, and  $V_T$  = the total culture volume in L. The percent of nitrogen converted to N<sub>2</sub>O was then calculated using:

$$EF = \frac{M_{N-converted}}{M_N} * 100$$

with EF = the percent of total nitrogen converted to N<sub>2</sub>O. Applying these equations to the N<sub>2</sub>O emissions observed resulted in an EF=0.003% for the oxic conditions and an EF=0.4% for the anoxic conditions.

#### 4. Scaling N<sub>2</sub>O Emissions using GHG impact from the LCA of Batan et. al. (2010)

The LCA done by Batan et al. indicates that an increase in GHG emissions of 0.392 g CO<sub>2</sub>-eq MJ<sup>-1</sup> would have a 1% impact on the overall GHG emissions.<sup>11</sup> The N<sub>2</sub>O concentration per flask per sample period that applies to this 1% impact level can be calculated by applying this knowledge and the following assumptions:

1. The microalgae growth rate remains constant at 0.2 g L<sup>-1</sup> day<sup>-1</sup>
2. The microalgae have an oil content of 40%, with the oil having an energy density of 32.3 MJ L<sup>-1</sup> and a density of 0.88 kg L<sup>-1</sup>
3. An illumination period of 16 hrs with a sample period of 8 hrs
4. A flask volume of 1.1 L and a culture volume of 0.5 L resulting in 0.6 L of gas with the assumption that the gas has the same density as air
5. A growth period of 5 days with nitrate consumed within 3 days

The GHG emissions per kg of biomass can be calculated using:

$$E_B = \frac{E_I * D_E * \%_o}{\rho_o}$$

with  $E_B$  = the emissions per biomass in g-CO<sub>2</sub>-eq kg-biomass<sup>-1</sup>,  $E_I$  = the emission level for 1% impact from Batan et. al. in kg CO<sub>2</sub>-eq MJ<sup>-1</sup>,  $D_E$  = the energy density of oil,  $\rho_o$  =

the density of the oil, and %<sub>o</sub> = the percent oil in the microalgae. Next the biomass produced per flask per sample period was calculated using:

$$B_p = \frac{G * V_c * t_s}{t_l * 10^3}$$

with  $B_p$  = the biomass produced in kg-biomass flask<sup>-1</sup> sample-period<sup>-1</sup>,  $G$  = the growth rate in g L<sup>-1</sup> day<sup>-1</sup>,  $V_c$  = the culture volume,  $t_s$  = the sample time, and  $t_l$  = the illumination time. The mass of N<sub>2</sub>O emissions per flask per sample period were then found using:

$$E_{N_2O} = \frac{B_p * E_B}{GWP_{N_2O}}$$

with  $E_{N_2O}$  = the N<sub>2</sub>O emissions in g-N<sub>2</sub>O flask<sup>-1</sup> sample-period<sup>-1</sup>, and  $GWP_{N_2O}$  = the IPCC global warming potential of N<sub>2</sub>O as a CO<sub>2</sub>-eq. Lastly, the N<sub>2</sub>O concentration per flask per sample period that would have a 1% impact on the total GHG emissions was calculated using:

$$C_{N_2O} = \frac{E_{N_2O}}{V_g * \rho_g} * 10^6$$

with  $C_{N_2O}$  = the concentration of N<sub>2</sub>O in ppm flask<sup>-1</sup> sample-period<sup>-1</sup>,  $V_g$  = the volume of gas, and  $\rho_g$  = the density of the gas. Using these equations and assumptions, a 1% impact on the overall GHG emissions was calculated to be 1.34 ppm of N<sub>2</sub>O per flask per sample period for the experimental setup described in this study.

This 1% impact level of 1.34 ppm per flask per sample period was applied to the average concentrations observed in this study. The average N<sub>2</sub>O concentration per 5 day growth period, per flask, per 8 hour sample accumulation period was calculated using:

$$C_{N_2O.avg} = \frac{(C_{N_2O.d} + 2 * C_{N_2O.l}) * 3}{15}$$

with  $C_{N_2O.avg}$  = the average concentration of N<sub>2</sub>O per sample period,  $C_{N_2O.d}$  = concentration of N<sub>2</sub>O observed over the dark period in ppm, and  $C_{N_2O.l}$  = concentration of N<sub>2</sub>O observed over the light period in ppm. The percent of impact on the net GHG emissions was then calculated using:

$$\%_I = \frac{C_{N_2O.avg}}{1.34}$$

with  $\%_I$  = the percent of impact on the GHG LCA. Using these calculations resulted in an increase of 0.149% for the oxic conditions, 16.6% for the anoxic conditions, and 74.5% for the maximum emissions observed.

## B. Detailed Timeline of Experimental Procedure

### 1. Baseline Growth

1.1. Validation of flask growing conditions

1.2. Push 2% CO<sub>2</sub> continuously into headspace while lights are on

1.3. Track growth and nitrate concentration

### 2. Initial test of pH control

2.1. Validation of pH control method

2.2. pH control and carbon source without CO<sub>2</sub>

2.2.1. Sodium bicarbonate used as CO<sub>2</sub> alternative for carbon source

2.2.2. pH controlled with 25mM HEPES buffer and hydrochloric acid (HCl)  
when required

2.3. Push air into closed head space and monitor pH every 8 hours

2.4. Maintain pH between 6.8-8.2

2.5. Monitor growth to verify pH control does not alter microalgae growth or nitrogen uptake rate

### 3. Nitrogen-filled Headspace (Anoxic Conditions)

3.1. Experiment will begin with the inoculation of culture into nutrient rich media

3.1.1. Pulsed N<sub>2</sub> delivery every 8hrs

3.1.2. pH control as previously described

### 3.2. Sampling

3.2.1. Dissolved O<sub>2</sub> content every 15 minutes for 24 hours

3.2.2. Sampling of headspace exhaust done 2 x daily, (end of dark period, half way through light period) using scrubbing tubes and FTIR

3.2.3. pH monitored 2x daily (end of dark period, half way through light cycle),  
HCl added as required

3.2.4. Nitrate concentration and growth measured 1x daily at end of dark period

3.3. Culture will grow for 5 days

4. Nitrogen-filled Headspace - 2<sup>nd</sup> and 3<sup>rd</sup> runs

4.1. Repeat as above

5. Air-filled Headspace (Oxic Conditions)

5.1.1. Same as N<sub>2</sub> headspace experiment except with a pulsed air delivery every  
8hrs

6. Air in Headspace - 2<sup>nd</sup> and 3<sup>rd</sup> runs

6.1. Repeat as above

7. Antibiotic Treatment - Verification of Denitrifying Bacteria Production Route

7.1. Experiment will begin with the inoculation of culture into nutrient rich media

7.1.1. Pulsed N<sub>2</sub> delivery every 8hrs

7.1.2. pH control as previously described

7.2. Antibiotic Treatment

7.2.1. Antibiotics added to F1 and F2

7.2.1.1. 100 mg/L Penicillin G Potassium Salt

7.2.1.2. 25 mg/L Streptomycin Sulfate Salt

7.2.1.3. 1/4 dose added 2x daily after initial dose

7.2.2. F3 served as a control

7.3. Sampling



- 7.3.1. Headspace exhaust sampling done 1x daily at end of dark period using scrubbing tubes and FTIR
- 7.3.2. pH will be monitored 2x daily (end of dark period, half way through light cycle), HCl added as needed
- 7.3.3. Nitrate and growth measured 1x daily at end of dark period
- 7.4. Culture will grow for 4 days
- 8. Denitrifying Bacteria Gene Sequencing
  - 8.1. DNA extraction and a PCR assay on culture to isolate and identify the *norBC* gene
    - 8.1.1. Filtration (1.2 micrometers) to remove microalgae
    - 8.1.2. Prokaryotic DNA extraction
    - 8.1.3. PCR assay using *norB* primers
      - 8.1.3.1. UV visualization using 1% agarose gel

## C. SOP's: Nitrogen Assay, PCR Assay, Agarose Gel

### *1. SOP Nitrate Assay*

#### 1. Equipment and Supplies

- 1.1. Hach DR 5000 Spectrophotometer
- 1.2. 1.2  $\mu\text{m}$  syringe filters
- 1.3. 1M hydrochloric acid (HCl) solution
- 1.4. Quartz cuvette, 4 mL capacity

#### 2. Procedure

- 2.1. Turn on spectrophotometer if it is not already on.
- 2.2. Install appropriate cuvette holder (10mm)
- 2.3. Start Hach program 357, stored under favorite programs.
- 2.4. Sample preparation
  - 2.4.1. Sample must be prepared in a total volume of 5 mL.
    - 2.4.1.1. Note: cultures must be filtered prior to testing. Filtration can be performed using a 1.2  $\mu\text{m}$  syringe filter or other suitable filter or by spinning down for 3 minutes at 14000rpm.
    - 2.4.1.2. The nitrate level of the sample must be within the range of the assay (1-10 mg/L).
      - 2.4.1.2.1. A ten-fold dilution of culture filtrate normally results in a sample that is within the range of the assay. For example, 4.4 mL DI water, 500  $\mu\text{L}$  culture filtrate, and 100  $\mu\text{L}$  1 M HCl.

2.4.1.2.2. A twenty-fold (or more) dilution of media normally results in a sample that is within the range of the assay. For example, 4.65 mL DI water, 250  $\mu$ L medium, and 100  $\mu$ L of 1 M HCl

#### 2.4.2. Sample

2.5. Zero the spectrophotometer with a 4mL quartz cuvette filled with DI water. The cuvette should be placed in the 10mm slot and the Q (clear side) should be facing forward.

2.6. Solutions not containing culture (i.e. media) may be measured without filtration. However measurements on culture require that the sample be filtered.

2.6.1. To obtain filtrate from culture pass the culture through a 1.2 $\mu$ m syringe filter.

2.7. Prepare a 5mL dilution of sample with DI to within the range of the assay (1-10mg/L)

2.7.1. Dilution must include 100  $\mu$ L of 1N HCl, and compensated for by subtracting DI (1:10 dilution = of 4.4mL DI, 100 $\mu$ L 1M HCl, and 500 $\mu$ L sample).

2.7.2. A 1:10 dilution is generally appropriate for measurements on culture filtrate. A 1:20 (4.65mL DI, 100 $\mu$ L 1M HCl, 250 $\mu$ L sample) or higher is often appropriate for medias. The assay will not measure over 10mg/L N-NO<sub>3</sub> use a dilution factor that brings your sample below this value.

2.8. Clean and dry the quartz cuvette with a kimwipe.

2.9. Mix sample and pour into quartz cuvette, place cuvette in holder, close the door, and press read.

2.10. Dispose of solution into proper nitrate assay waste container.

## 2. SOP PCR Assay:

### 1. PCR Preparation

1.1. Wipe down bench and pipettes with 70% ethanol

1.2. Label PCR tubes on the side (1 per sample + 1 blank)

1.3. Put PCR tubes, a 2 ml tube (for the PCR mix) and water (Nanopure H<sub>2</sub>O previously autoclaved) in a 2 ml tube in the UV crosslinker for at least 5 minutes

### 2. Prepare the PCR Mix

2.1. Each reaction is 50  $\mu$ l and contains buffer, 2 primers, dNTPs, MgSO<sub>4</sub>, Taq polymerase, BSA, template DNA, and water

2.2. Calculate the volumes of all PCR reagents (excluding water and template DNA) needed for 1 reaction then calculate the volumes required for the number of reactions you are running plus 2 extra.

2.3. Calculate the water required for a 50  $\mu$ l reaction for each PCR tube (Water vol = 50  $\mu$ l - vol mix for 1 rxn - vol template DNA), and add water to PCR tubes

2.4. Add PCR reagents to 2 ml tube, keeping Taq in the freezer as long as possible, then vortex and add PCR mix (volume for 1 reaction) to each PCR tube

2.5. Add template DNA to each PCR tube

### 3. Running the PCR:

3.1. Place the PCR tubes in the thermocycler

3.2. Either write or select the PCR program and run

### 4. Visualizing the PCR

- 4.1. After the PCR program has finished, prepare an agarose gel and visualize under UV

### 3. SOP 1% Agarose Gel:

#### 1. Agarose Gel

- 1.1. In a 250 mL Erlenmeyer flask, weigh 1 g of agarose and 100 ml of 1X TAE
- 1.2. Microwave for 2 to 3 min, mixing several times
- 1.3. Add 3  $\mu$ l of GelRed (specs) into the flask and mix
- 1.4. Wrap the flask with aluminum foil and store at room temperature

#### 2. Gel Preparation

- 2.1. Level the mold
- 2.2. Place comb into the mold
- 2.3. Microwave gel until boiling and completely clear
- 2.4. Pour the gel to desired thickness (~25 ml)
- 2.5. Keeping dark, wait for gel to solidify

#### 3. Running Gel

- 3.1. On parafilm mix 10  $\mu$ l of PCR or DNA extraction product with 3  $\mu$ l of blue dye
- 3.2. Gently remove the comb from the solid gel
- 3.3. Place the gel into the electrophoresis cuvette and submerge with 1X TAE
- 3.4. Load 8  $\mu$ l of 1kb DNA ladder into the first lane of the gel and load samples into remaining lanes
  - 3.4.1. Store DNA ladder and blue dye at 4°C
- 3.5. Close the cuvette and start the generator at 100 V
  - 3.5.1. Bubbles forming close to the negative side indicate proper function

3.6. Keep dark and run for ~20 min

3.7. Stop the electrophoresis and visualize the gel under UV

## REFERENCES

1. Energy Information Administration World Crude Oil Prices. [http://tonto.eia.doe.gov/dnav/pet/pet\\_pri\\_wco\\_k\\_w.htm](http://tonto.eia.doe.gov/dnav/pet/pet_pri_wco_k_w.htm) (accessed 2011).
2. Department of Energy, Alternative Fuel Transportation Program; Replacement Fuel Goal Modification In *Office of Energy Efficiency and Renewable Energy* 2007; Vol. 72.
3. Dismukes, G. C.; Carrieri, D.; Bennette, N.; Ananyev, G. M.; Posewitz, M. C., Aquatic phototrophs: efficient alternatives to land-based crops for biofuels. *Curr. Opin. Biotechnol.* **2008**, *19* (3), 235-240.
4. Brown, L. M.; Zeiler, K. G., Aquatic Biomass and Carbon-Dioxide Trapping. *Energy Conversion and Management* **1993**, *34* (9-11), 1005-1013.
5. Li, Y.; Horsman, M.; Wu, N.; Lan, C. Q.; Dubois-Calero, N., Biofuels from microalgae. *Biotechnol. Prog.* **2008**, (24), 815-820.
6. Raja, R.; Hemaiswarya, S.; Kumar, N. A.; Sridhar, S.; Rengasamy, R., A perspective on the biotechnological potential of microalgae. *Crit. Rev. Microbiol.* **2008**, *34* (2), 77-88.
7. Posten, C.; Schaub, G., Microalgae and terrestrial biomass as source for fuels-A process view. *J. Biotechnol.* **2009**, *142* (1), 64-69.
8. Williams, P. R. D.; Inman, D.; Aden, A.; Heath, G. A., Environmental and Sustainability Factors Associated With Next-Generation Biofuels in the US: What Do We Really Know? *Environ. Sci. Technol.* **2009**, *43* (13), 4763-4775.
9. Schenk, P. M.; Thomas-Hall, S. R.; Stephens, E.; Marx, U. C.; Mussgnug, J. H.; Posten, C.; Kruse, O.; Hankamer, B., Second Generation Biofuels: High-Efficiency Microalgae for Biodiesel Production. *BioEnergy Research* **2008**, *1* (1), 20-43.
10. Wijffels, R. H.; Barbosa, M. J., An Outlook on Microalgal Biofuels. *Science* **2010**, *329* (5993), 796-799.

11. Batan, L.; Quinn, J.; Willson, B.; Bradley, T., Net Energy and Greenhouse Gas Emission Evaluation of Biodiesel Derived from Microalgae. *Environ. Sci. Technol.* **2010**, *44*, 7975-7980.
12. Yamaberi, K.; Takagi, M.; Yoshida, T., Nitrogen depletion for intracellular triglyceride accumulation to enhance liquefaction yield of marine microalgal cells into a fuel oil. *Journal of Marine Biotechnology* **1998**, *6* (1), 44-48.
13. Chisti, Y., Response to Reijnders: Do biofuels from microalgae beat biofuels from terrestrial plants? *Trends Biotechnol.* **2008**, *26* (7), 351-352.
14. Greenwell, H. C.; Laurens, L. M. L.; Shields, R. J.; Lovitt, R. W.; Flynn, K. J., Placing microalgae on the biofuels priority list: a review of the technological challenges. *J. Royal Soc. Interface* **2010**, *7* (46), 703-726.
15. Sheehan, J.; Dunahay, T.; Benemann, J.; Roessler, P., A look back at the US department of Energy's Aquatic Species Program: biodiesel from algae. **1998**.
16. Weathers, P. J., N<sub>2</sub>O Evolution by Green Algae. *Applied and Environmental Microbiology* **1984**, *48* (6), 1251-1253.
17. Florez-Leiva, L.; Tarifeno, E.; Cornejo, M.; Kiene, R.; Farfñas, L., High production of nitrous oxide (N<sub>2</sub>O), methane (CH<sub>4</sub>) and dimethylsulphoniopropionate (DMS) in a massive marine phytoplankton culture. *Biogeosciences Discuss* **2010**, *7* (5).
18. IPCC, *2006 IPCC Guidelines for National Greenhouse Gas Inventories*. National Greenhouse Gas Inventories Programme: Japan, 2006; Vol. 4.
19. Solomon, S.; Qin, D.; Manning, M.; Chen, Z.; Marquis, M.; Averyt, K. B.; Tignor, M.; (eds.), H. L. M., *Climate Change 2007: Contribution of Working Group I to the Fourth Assessment Report of the Intergovernmental Panel on Climate Change*. Cambridge University Press: Cambridge, United Kingdom and New York, NY, USA, 2007.
20. Aresta, M.; Dibenedetto, A.; Barberio, G. In *Utilization of macro-algae for enhanced CO<sub>2</sub> fixation and biofuels production: Development of a computing software for an LCA study*, 2005; pp 1679-1693.
21. Lardon, L.; Helias, A.; Sialve, B.; Stayer, J. P.; Bernard, O., Life-Cycle Assessment of Biodiesel Production from Microalgae. *Environ. Sci. Technol.* **2009**, *43* (17), 6475-6481.
22. Luo, D.; Hu, Z.; Choi, D. G.; Thomas, V. M.; Realff, M. J.; Chance, R. R., Life Cycle Energy and Greenhouse Gas Emissions for an Ethanol Production Process Based on Blue-Green Algae. *Environ. Sci. Technol.* **2010**, *44* (22), 8670-8677.



23. Clarens, A. F.; Resurreccion, E. P.; White, M. A.; Colosi, L. M., Environmental Life Cycle Comparison of Algae to Other Bioenergy Feedstocks. *Environ. Sci. Technol.* **2010**, *44* (5), 1813-1819.
24. Campbell, P. K.; Beer, T.; Batten, D., Life cycle assessment of biodiesel production from microalgae in ponds. *Bioresour. Technol.* **2011**, *102* (1), 50-56.
25. Stephenson, A. L.; Kazamia, E.; Dennis, J. S.; Howe, C. J.; Scott, S. A.; Smith, A. G., Life-Cycle Assessment of Potential Algal Biodiesel Production in the United Kingdom: A Comparison of Raceways and Air-Lift Tubular Bioreactors. *Energy & Fuels* **2010**, *24* (7), 4062-4077.
26. Hirano, A.; Hon-Nami, K.; Kunito, S.; Hada, M.; Ogushi, Y., Temperature effect on continuous gasification of microalgal biomass: theoretical yield of methanol production and its energy balance. *Catalysis Today* **1998**, *45* (1-4), 399-404.
27. Jones, C. M.; Stres, B.; Rosenquist, M.; Hallin, S., Phylogenetic Analysis of Nitrite, Nitric Oxide, and Nitrous Oxide Respiratory Enzymes Reveal a Complex Evolutionary History for Denitrification. *Mol. Biol. Evol.* **2008**, *25* (9), 1955-1966.
28. Kotzerke, A.; Klemer, S.; Kleineidam, K.; Horn, M.; Drake, H.; Schloter, M.; Wilke, B.-M., Manure contaminated with the antibiotic sulfadiazine impairs the abundance of *nirK*- and *nirS*-type denitrifiers in the gut of the earthworm *Eisenia fetida*. *Biol. Fertil. Soils* **2010**, *46* (4), 415-418.
29. Golterman, H., *Denitrification in the Nitrogen Cycle*. Plenum Press: New York, New York, 1985.
30. Horn, M. A.; Drake, H. L.; Schramm, A., Nitrous Oxide Reductase Genes (*nosZ*) of Denitrifying Microbial Populations in Soil and the Earthworm Gut Are Phylogenetically Similar. *Appl. Environ. Microbiol.* **2006**, *72* (2), 1019-1026.
31. Delwiche, C. C., *Denitrification, Nitrification, and Atmospheric Nitrous Oxide*. John Wiley & Sons: New York, 1981.
32. Bothe, H., *Biology of the Nitrogen Cycle*. 1 ed.; Elsevier: Amsterdam, Netherlands, 2007.
33. Hino, T.; Matsumoto, Y.; Nagano, S.; Sugimoto, H.; Fukumori, Y.; Murata, T.; Iwata, S.; Shiro, Y., Structural Basis of Biological N<sub>2</sub>O Generation by Bacterial Nitric Oxide Reductase. *Science* **2010**, *330* (6011), 1666-1670.
34. Kandeler, E.; Deiglmayr, K.; Tscherko, D.; Bru, D.; Philippot, L., Abundance of *narG*, *nirS*, *nirK*, and *nosZ* Genes of Denitrifying Bacteria during Primary

- Successions of a Glacier Foreland. *Appl. Environ. Microbiol.* **2006**, 72 (9), 5957-5962.
35. Chon, K.; Chang, J.-S.; Lee, E.; Lee, J.; Ryu, J.; Cho, J., Abundance of denitrifying genes coding for nitrate (narG), nitrite (nirS), and nitrous oxide (nosZ) reductases in estuarine versus wastewater effluent-fed constructed wetlands. *Ecological Engineering* **2009**, 37 (1), 64-69.
  36. Throbäck, I. N.; Enwall, K.; Jarvis, Å.; Hallin, S., Reassessing PCR primers targeting nirS, nirK and nosZ genes for community surveys of denitrifying bacteria with DGGE. Blackwell Publishing Ltd: 2004; Vol. 49, pp 401-417.
  37. Braker, G.; Tiedje, J. M., Nitric Oxide Reductase (norB) Genes from Pure Cultures and Environmental Samples. *Appl. Environ. Microbiol.* **2003**, 69 (6), 3476-3483.
  38. Sacks, L. E.; Barker, H. A., The Influence of Oxygen on Nitrate and Nitrite Reduction. *J. Bacteriol.* **1949**, 58 (1), 11-22.
  39. Yeh, K.-L.; Chang, J.-S.; chen, W.-m., Effect of light supply and carbon source on cell growth and cellular composition of a newly isolated microalga *Chlorella vulgaris* ESP-31. *Eng. Life Sci.* **2010**, 10 (3), 201-208.
  40. Altenburger, R.; Krüger, J.; Eisenträger, A., Proposing a pH stabilised nutrient medium for algal growth bioassays. *Chemosphere* **2010**, 78 (7), 864-870.
  41. Andersen, R. A., *Algal Culturing Techniques*. Elsevier: 2005.
  42. Mohn, J.; Zeeman, M. J.; Werner, R. A.; Eugster, W.; Emmenegger, L., Continuous field measurements of <sup>13</sup>C-CO<sub>2</sub> and trace gases by FTIR spectroscopy. *Isotopes in Environmental Health Studies* **2008**, 44, 241-251.
  43. Esler, M. B.; Griffith, D. W. T.; Turatti, F.; Wilson, S. R.; Rahn, T.; Zhang, H., N<sub>2</sub>O concentration and flux measurements and complete isotopic analysis by FTIR spectroscopy. *Chemosphere - Global Change Science* **2000**, 2 (3-4), 445-454.
  44. Kagann, R. H., Infrared absorption intensities for N<sub>2</sub>O. *J. Mol. Spectrosc.* **1982**, 95 (2), 297-305.
  45. Ryden, J. C.; Lund, L. J.; Focht, D. D., Direct In-field Measurement of Nitrous Oxide Flux from Soils<sup>1</sup>. *Soil Sci. Soc. Am. J.* **1978**, 42 (5), 731-737.
  46. Mosier, A. R.; Mack, L., Gas Chromatographic System for Precise, Rapid Analysis of Nitrous Oxide<sup>1</sup>. *Soil Sci. Soc. Am. J.* **1980**, 44 (5), 1121-1123.

47. Virkajärvi, P.; Maljanen, M.; Saarijärvi, K.; Haapala, J.; Martikainen, P. J., N<sub>2</sub>O emissions from boreal grass and grass - clover pasture soils. *Agriculture, Ecosystems & Environment* **2010**, *137* (1-2), 59-67.
48. Maljanen, M.; Liikanen, A.; Silvola, J.; Martikainen, P. J., Measuring N<sub>2</sub>O emissions from organic soils by closed chamber or soil/snow N<sub>2</sub>O gradient methods. *Eur. J. Soil Sci.* **2003**, *54* (3), 625-631.
49. Pouchert, C. J., *The Aldrich Library of FT-IR Spectra*. 1 ed.; Aldrich Chemical Company, Inc.: Milwaukee, 1989.
50. Lee, S.-W.; Im, J.; DiSpirito, A.; Bodrossy, L.; Barcelona, M.; Semrau, J., Effect of nutrient and selective inhibitor amendments on methane oxidation, nitrous oxide production, and key gene presence and expression in landfill cover soils: characterization of the role of methanotrophs, nitrifiers, and denitrifiers. *Appl. Microbiol. Biotechnol.* **2009**, *85* (2), 389-403.
51. Skerman, V. B. D.; Macrae, I. C., The Influence of Oxugen on the Reduction of Nitrate by Adapted Cells of Pseudomonas Denitrificans. *Can. J. Microbiol.* **1957**, *3* (2), 215-230.
52. Jannasch, H. W., Denitrification as Influenced by Photosynthetic Oxygen Production. *J. Gen. Microbiol.* **1960**, *23* (1), 55-63.
53. Flynn, K. J.; Davidson, K.; Leftley, J. W., Carbon-Nitrogen Relations During Batch Growth of *Nannochloropsis oculata* (*Eustigmatophyceae*) Under Alternating Light and Dark. *J. Appl. Phycol.* **1993**, *5* (4), 465-475.
54. Takagi, M.; Watanabe, K.; Yamaberi, K.; Yoshida, T., Limited feeding of potassium nitrate for intracellular lipid and triglyceride accumulation of *Nannochloris* sp UTEX LB1999. *Appl. Microbiol. Biotechnol.* **2000**, *54* (1), 112-117.
55. Skerman, V. B. D.; Macrae, I. C., The Influence of Oxygen Availability on the Degree of Nitrate Reduction by Pseudomonas-Denitrificans. *Can. J. Microbiol.* **1957**, *3* (3), 505-530.
56. Falk, S.; Liu, B.; Braker, G., Isolation, genetic and functional characterization of novel soil nirK-type denitrifiers. *Syst. Appl. Microbiol.* **2010**, *33* (6), 337-347.