



CIRA ANNUAL REPORT FY 2016/2017 (Reporting Period April 1, 2016 – March 31, 2017)

COOPERATIVE INSTITUTE FOR RESEARCH IN THE ATMOSPHERE

DIRECTOR'S MESSAGE

The Cooperative Institute for Research in the Atmosphere (CIRA) at Colorado State University (CSU) is one of a number of cooperative institutes (CIs) that support NOAA's mission. Although this mission continues to evolve, there continue to be strong reasons for partnering between NOAA and the fundamental research being done in the University environment and the students it entrains into NOAA's mission. Strengthening these ties in satellite remote sensing and regional/global weather prediction, as well as application development, education/training, data assimilation, and data distribution technology make CIRA a valuable asset to NOAA. As the Director of CIRA, I have tried to do everything possible to strengthen CIRA's ties not only among CSU's Department of Atmospheric Science, the College of Engineering, and the University but also the ties among the different groups within CIRA that now covers researchers in Fort Collins and College Park associated with NESDIS, researchers in Boulder working closely with OAR and researchers in Kansas City working with the National Weather Service. With a renewed emphasis on interactions and joint initiatives such as our Data Assimilation intern program, we are focusing on Connecting Models and Observations as the underlying principle that guides us in our daily decisions. With this, we hope to fulfill the promise of being the conduit for developing ground breaking research to address socially-relevant problems that face NOAA and our society today as well as to help train a new workforce that has a broader perspective needed to continue developing decision support tools guided by scientific advances.

CIRA is fortunate in that its corporate culture and proximity to many of the Nation's top research institutions have allowed it to work with talented researchers and support staff who continue to perform at the highest possible level. There are many important accomplishments that are highlighted in this report and summarized in the executive summary. The new GOES-16 activities are certainly a great source of pride. Not as obvious, but equally important, are the activities that CIRA carries out with the National Park Service and the activities with NASA through the CloudSat data processing facility and OCO and GeoCarb algorithm development. While not funded by NOAA, these activities are highly synergistic in the areas of algorithm development, modeling and data distribution. They allow CIRA researchers working on exciting new satellite data to have access to other experts with whom they can consult as they develop their own projects. This progress report constitutes the third year of reporting under the second 5-year term of the Cooperative Agreement. With it, we again establish our commitment to the maintenance and growth of a strong collaborative relationship with NOAA, other national programs, the Department of Atmospheric Science at CSU, and the University as a whole.

Christian D. Kummerow

COOPERATIVE INSTITUTE FOR RESEARCH IN THE ATMOSPHERE

The Cooperative Institute for Research in the Atmosphere (CIRA) was established in 1980 at Colorado State University (CSU). CIRA serves as a mechanism to promote synergisms between University scientists and those in the National Oceanic and Atmospheric Administration (NOAA). Since its inception, CIRA has expanded and diversified its mission to coordinate with other Federal agencies, including the National Aeronautics and Space Administration (NASA), the National Park Service (NPS), the U.S. Forest Service, and the Department of Defense (DoD). CIRA is a multi-disciplinary research institute within the College of Engineering (CoE) and encompasses several cooperative agreements, as well as a substantial number of individual grants and contracts. The Institute's research for NOAA is concentrated in five theme areas and two cross-cutting research areas:

Satellite Algorithm Development, Training and Education - Research associated with development of satellite-based algorithms for weather forecasting, with emphasis on regional and mesoscale meteorological phenomenon. This work includes applications of basic satellite products such as feature track winds, thermodynamic retrievals, sea surface temperature, etc., in combination with model analyses and forecasts, as well as in situ and other remote sensing observations. Applications can be for current or future satellites. Also under this theme, satellite and related training material will be developed and delivered to a wide variety of users, with emphasis on operational forecasters. A variety of techniques can be used, including distance learning methods, web-based demonstration projects and instructor-led training.

Regional to Global Scale Modeling Systems - Research associated with the improvement of weather/climate models (minutes to months) that simulate and predict changes in the Earth system. Topics include atmospheric and ocean dynamics, radiative forcing, clouds and moist convection, land surface modeling, hydrology, and coupled modeling of the Earth system.

Data Assimilation - Research to develop and improve techniques to assimilate environmental observations, including satellite, terrestrial, oceanic, and biological observations, to produce the best estimate of the environmental state at the time of the observations for use in analysis, modeling, and prediction activities associated with weather/climate predictions (minutes to months) and analysis.

Climate-Weather Processes - Research focusing on using numerical models and environmental data, including satellite observations, to understand processes that are important to creating environmental changes on weather and short-term climate timescales (minutes to months) and the two-way interactions between weather systems and regional climate.

Data Distribution - Research focusing on identifying effective and efficient methods of quickly distributing and displaying very large sets of environmental and model data using data networks, using web map services, data compression algorithms, and other techniques.

Cross-Cutting Area 1: Assessing the Value of NOAA Research via Societal/Economic Impact Studies - Consideration for the direct and indirect impacts of weather and climate on society and infrastructure. Providing metrics for assessing the value of NOAA/CI research and tools for planners and decision makers. Achieving true 'end-to-end' systems through effective communication of information to policy makers and emergency managers.

Cross-Cutting Area 2: Promoting Education and Outreach on Behalf of NOAA and the University - Serving as a hub of environmental science excellence at CSU for networking resources and research activities that align with NOAA mission goals throughout the University and with its industrial partners. Engaging K-12 and the general public locally, regionally, nationally and internationally to promote both awareness and informed views on important topics in environmental science.

Annually, CIRA scientists produce over 200 scientific publications, 30% of which appear in peer-reviewed publications. Among the important research being performed at CIRA is its support of NESDIS' next-generation satellite programs: GOES-R and JPSS. These two multi-billion dollar environmental satellite programs will support weather forecasting and climate monitoring for the next 2-3 decades. They will include vastly improved sensors and will offer higher-frequency data collection. CIRA research is building prototype products and developing training, based on the new sensor technology, to assure maximum exploitation of these data when the sensors are launched.

CIRA EDUCATION, TRAINING AND OUTREACH ACTIVITIES: 2016-2017

From the CIRA Mission Statement: *“Important bridging elements of the CI include the communication of research findings to the international scientific community, transition of applications and capabilities to NOAA operational users, education and training programs for operational user proficiency, outreach programs to K-12 education and the general public for environmental literacy, and understanding and quantifying the societal impacts of NOAA research.”*

Summary of CIRA Outreach

CIRA Outreach efforts during 2016 focused on identified needs facing the Nation: Improved professional development for standards-based education, addressing community resilience in the face of natural disasters, including wildfires, floods, and droughts, and increasing the visibility of NOAA-generated products in the public eye. Along with these efforts, CIRA continued supporting pre-existing programs and collaborations; leveraging partnerships between CIRA’s proven history with new opportunities will continue to define the direction of the E&O program for the next several years.

Teacher Professional Development

CIRA continued its commitment to professional development opportunities for fifth-grade teachers, especially with respect to meeting Next-Generation Science Standards (NGSS) and Colorado Department of Education requirements. As detailed previously, teachers are held to exacting standards and are required to provide students with sophisticated and detailed instruction regarding complex natural phenomena. An example of the standards to which teachers are held, taken from the State of Colorado fifth-grade standard, is provided as Figure 1.

Note the subtle complexity in the standard: Students are expected to master the concept that weather conditions change ‘because of the uneven heating of Earth’s surface by the Sun’s energy.’ Included in this concept are the rotation of the Earth and the complex interactions of fluid- and thermodynamics, resulting in weather systems. Students are then expected to demonstrate an understanding of these weather systems as made evident by direct observation of temperature, pressure, wind direction and speed, etc.

The formal preparation for fifth-grade science teachers rarely goes into these kinds of detail in the Earth Sciences; teachers are left to fend for themselves in getting up to speed in the background needed to teach this element of the standards (and with many of the other intensive standards in which they also lack a formal education). NOAA Cooperative Institutes can offer a formidable resource to meet these needs. In this role, CIRA has developed and implemented a formal fifth-grade weather protocol training course which has been presented and updated with six different course dates during the year to approximately twelve local teachers. In addition, CIRA efforts in this arena have led to funding opportunities wherein local schools have applied for, and received, external funds to set up ‘weather clubs’ which has been a popular recruitment tool and may serve as a vehicle for expansion of the CIRA professional development endeavor for 2017. CIRA has a professional development presence in approximately 20% of the schools in the Poudre School District and is developing traction outside of the district as well.

Grade Level Expectation: Fifth Grade

Concepts and skills students master:

3. Weather conditions change because of the uneven heating of Earth's surface by the Sun's energy. Weather changes are measured by differences in temperature, air pressure, wind and water in the atmosphere and type of precipitation

Evidence Outcomes

Students can:

- Develop and communicate an evidence-based scientific explanation for changes in weather conditions (DOK 1-3)
- Gather, analyze, and interpret data such as temperature, air pressure, wind, and humidity in relation to daily weather conditions (DOK 1-3)
- Describe weather conditions based on data collected using a variety of weather tools (DOK 1-2)
- Use data collection tools and measuring devices to gather, organize, and analyze data such as temperature, air pressure, wind, and humidity in relation to daily weather conditions (DOK 1-2)

21st Century Skills and Readiness Competencies

Inquiry Questions:

- Why does the Sun heat different surfaces at different rates?
- Why does the weather change from day to day?

Relevance and Application:

- The Sun's energy helps change daily weather by influencing the water cycle, air movement, and temperature.
- Gliders and birds exploit updrafts created by thermals.
- Deicing airplanes in the winter is sometimes necessary so that they can fly.
- Weather satellites generate data that measure and monitor changes in weather.

Nature of Science:

- Support explanations of weather using evidence. (DOK 2-3)
- Understand how weather maps are utilized to predict the weather from day to day. (DOK 1-2)
- Assess and provide feedback on other student's scientific explanations about weather, pushing for reasoning based on evidence and scientific principles. (DOK 2-3)

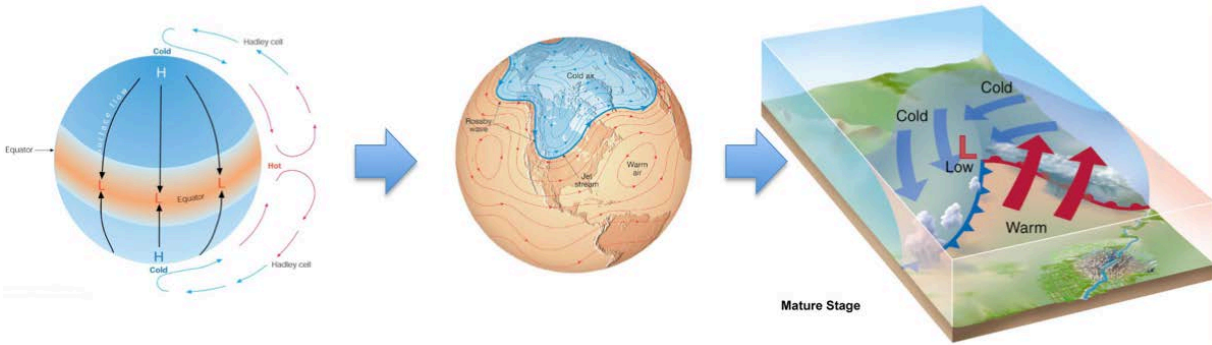

Figure 1. Fifth-grade weather standards and expectations related through CIRA-developed professional development courses.

Social Media

The launch of the GOES-R (now GOES-16) satellite in 2016 offered outstanding opportunities for social media presence and growth for CIRA during 2016. Since the last reporting period, CIRA has increased its number of social media followers by a factor of 12 and has seen several prominent re-tweets and re-postings of CIRA-developed content on major, publically-prominent NOAA feeds, improving the brand recognition and visibility of CIRA and NOAA-derived products. CIRA has also launched a LinkedIn page, allowing for CIRA employees to further represent CIRA online and drawing top talent to CIRA opportunities.

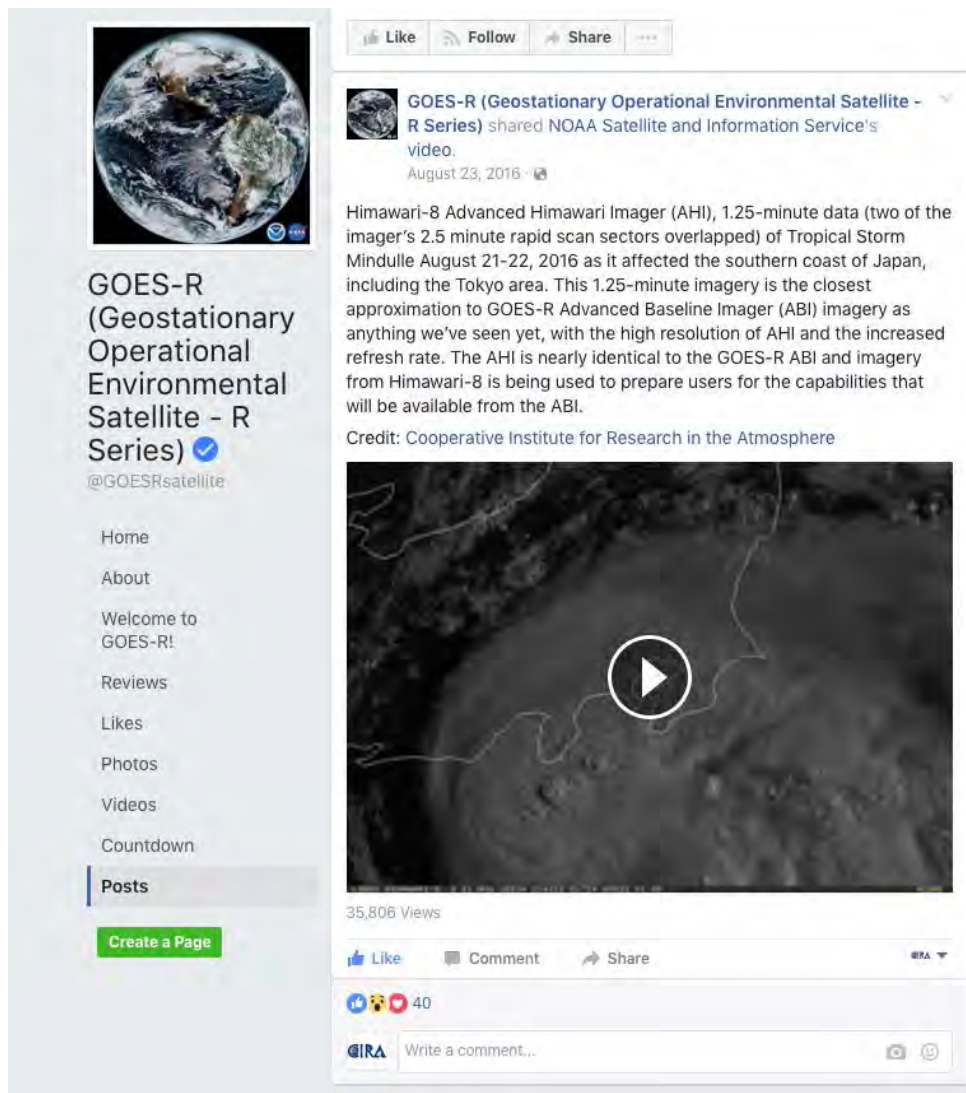

Figure 2. Reposting and broadcasting of CIRA AHI research on the operational GOES-R feed, drawing over 35,000 unique views for the single post.

Chengdu Workshop

CIRA Fellow Prof. V. Chandrasekar along with CIRA outreach staff led the organization of a workshop between Colorado State University and atmospheric and engineering faculty of the Chengdu University of Information Technology (CUIT) from China. Hosted in the last weeks of July and first week of August, approximately thirty researchers from CUIT interacted with and heard presentations from a wide range of CSU faculty, including presentations by CIRA Director Chris Kummerow and CIRA Deputy Director Steve Miller. Several opportunities for collaboration between CSU and CUIT were developed, particularly in the vein of local precipitation observations and aerosol interaction research, and future opportunities for CIRA and CSU staff to interact with CUIT in the future remain as a result of this fruitful workshop.



Figure 3. Participants from the Chengdu University of Information Technology workshop pose with CSU Engineering Associate Dean (and Mayor of Fort Collins) Wade Troxell.

Collaborations

Little Shop of Physics

CIRA continued its long and prosperous partnership with the Little Shop of Physics in 2016. The Little Shop of Physics develops hands-on demonstrations of physical concepts for the K-12 audience and supports professional development and science education for K-12 teachers. Utilizing undergraduate and graduate student volunteers, the Little Shop of Physics tours nationally and internationally (including a trip to Africa this year), bringing science demonstrations to a large audience. Additionally, the Little Shop produces a cable-access TV program, also available online, and presents demonstrations at national conferences including the AMS and NSTA Annual Meetings, and hosts an annual Open House on the CSU Campus that draws nearly 10,000 participants.



Figure 4. CIRA Volunteers staffing a cloud activity booth at the 2016 Little Shop of Physics Open House

Community Outreach

CIRA Outreach continues to support the local chapter of the AMS, FORTCAST, and responded to several requests for school visits on behalf of FORTCAST, including to underprivileged communities in Loveland. CIRA also made several visits to local elementary schools in 2016, providing an annual presentation on fire, flood, and drought to Olander Elementary and a bilingual presentation on clouds, rainbows, and lightning formation to the English- and Spanish-speaking kindergarten classes at Harris Bilingual Elementary. Additionally, CIRA Outreach staff were asked to judge at the annual Longs Peak Science and Engineering fair held in Greeley, CO, adjudicating the award of NOAA- and NASA-sponsored awards.



Interaction with World Meteorological Organization Regional Training Centers through the WMO Virtual Laboratory

CIRA is an active member of the World Meteorological Organization (WMO) Virtual Laboratory (VLab) and collaborates with WMO Regional Training Centers (RTC) in Costa Rica, Barbados, Argentina, and Brazil to promote satellite-focused training activities. One of our most productive activities with these RTCs continues to be providing support to monthly virtual weather/satellite briefings.

Our group is the WMO Focus Group of the Americas and the Caribbea, and we are a model group for other WMO countries. Participation in our monthly virtual satellite weather briefings is an easy and inexpensive way to simultaneously connect people from as many as 32 different countries, view imagery from Geostationary and polar orbiting satellites, and share information on global, regional, and local real time and climatic weather patterns, hurricanes, severe weather, flooding, and even volcanic eruptions. Forecasters and researchers are able to “build capacity” by being able to readily communicate with others in their discipline from different countries and discuss the impacts of their forecasts or impacts of broad reaching phenomena such as El Niño. Participants view the same imagery (geostationary and polar orbiting) using the VISITview tool and utilize GoToWebinar for voice over the Internet.

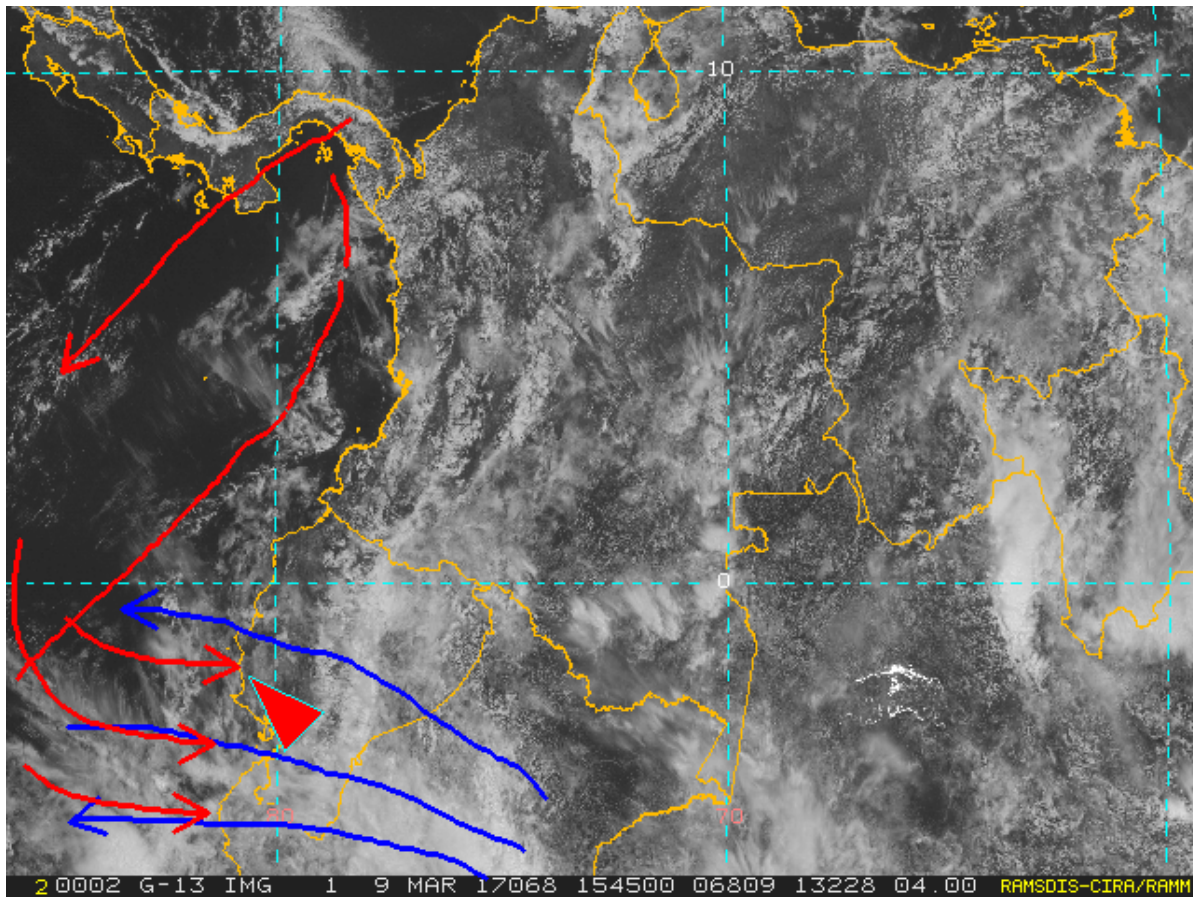

Figure 5. Complicated flow analyzed on GOES Visible imagery from 9 March 2017 used by VLab training. The VISITView tool allows easy real-time drawing and annotation of important weather features on the screen to assist student learning.

For more information on various RTC activities and recording of the sessions, visit:

<http://rammb.cira.colostate.edu/training/rmtc/focusgroup.asp>

Science on a Sphere™ - K. Searight, S. Albers

During this reporting period, new SOS systems were installed at venues worldwide including Spaceport Sheboygan (Wisconsin), Fair Oak Farms (Indiana), Kalamazoo Valley Museum (Michigan), Keesler Air Force Base (Mississippi), Santa Fe Community College (New Mexico), Yan'an Science and Technology Museum (China), Nehru Science Center (India), and The National Media Museum (England). The total number of SOS system installs worldwide now exceeds 140. The most recent estimate of the number of people worldwide that view SOS presentations is now 37M annually, a growth of over 10% from a few years ago.

In support of scientific education and outreach, portable SOS systems and SOS team members travelled to several conferences, including SciFest (Washington, DC), Earth Day (Texas), and the IUCN World Conservation Congress (Hawaii). SOS staff also led a Girls & Science program at Denver Museum of Nature and Science and facilitated webinars for the SOS community on scientific content and use of SOS software. In the SOS Planet Theater at the NOAA DSRC building in Boulder, SOS educational shows

were given to an average of 450 visitors per month, with SOS staff conducting some of the presentations or providing technical backup to presenters when needed.

Citizen Weather Observer Program (CWOP) - L. Cheatwood, R. Collander, T. Kent

There are currently 21,400 active stations (citizen and ham radio operators) out of a total of 34,974 stations in the CWOP database. CWOP members send their weather data via internet alone or internet-wireless combination to the findU (<http://www.findu.com>) server and then the data are sent from the findU server to the NOAA MADIS ingest server every five minutes. The data undergo quality checking and then are made available to users thru the MADIS distribution servers. CWOP is in the process of transitioning to operations within the NCO IDP MADIS system.

In 2016, there were approximately 2240 stations added to the database. Approximately 1685 revisions were made to site metadata. Adjustments include latitude, longitude and elevation changes in response to site moves, refinement of site location, and site status change (active to inactive, vice-versa).

Virtual Lab (VLab) - K. Sperow, M. Giebler, J. Burks

The NWS has created a service and IT framework that enables NOAA, in particular the NWS, and its partners to share ideas, collaborate, engage in software development, and conduct applied research from anywhere. Ken Sperow continued as the VLab technical lead, as well as the technical lead of the Virtual Lab Support Team (VLST). This team currently consists of 12 members to whom Ken provides support and training. Under Ken and Stephan Smith's (the NOAA PI) leadership, the VLab continues to grow in importance and visibility within the NWS and NOAA. Ken provided multiple demos and consultations to development and operational groups covering VLab's capabilities and how they can be leveraged to address the group's needs.

Autonowcaster (ANC) - J. Crockett

John traveled to Taipei, Taiwan, where he reconfigured the CWB's MDL-ANC system to ingest the composite radar reflectivity grid output by the CWB's Quantitative Precipitation Estimation and Segregation Using Multiple Sensors system, reconfigured the CWB's MDL-ANC system to ingest satellite data in a way which makes it more certain that those data are available, and fixed misconfigurations on both the CWB's operational TANC system and its MDL-ANC system. Afterwards, as the need arose, he investigated and fixed problems remotely.

Weather Information Statistical Post Processing System (WISPS) – J. Levit

Contributed to building a community-based software system through outreach to partners. Jason accompanied MDL personnel on outreach trips to CMC in Montreal, UKMet in Exter, UK and gave a presentation on WISPS at the National Weather Association and American Meteorological Society Annual Meetings. He also trained new employees assigned to the project on the use of MOS-2000 workflow and data, and worked with employees in incorporating initial MOS-2000 algorithms in the WISPS software infrastructure.

Hydrologic Research and Water Resources Applications Outreach – L. Johnson

Assisted in the design, coordination and development of hydrological modeling and water resources management applications for regional demonstrations with the Hydrometeorological Testbed (HMT) and NWS National Water Center (NWC).

Provided guidance and leadership in carrying forward the hydrological research agenda defined by the HMA Team, including publication in technical reports, peer-reviewed journals, and conferences.

Supported the HMA Team Leader in identifying and tracking candidate (and past) tools, techniques and knowledge transfers to NWS and key stakeholders.

Russian River Tributaries Water Budget Project

A hydrologic water budget model has been developed for the Feliz Creek watershed within the Russian River basin by combining the RDHM streamflow simulation model with the GIS-based Geo-MODSIM network streamflow model. (Figure 3)

A web-based interface has been developed for the dissemination of information to project stakeholders.

Instructional Development for NOAA's OMAO- J. Dalton

NOAA Diving Program

The OMAO CIRA Associate Jenna Dalton created a new version of this course that provides a Table of Contents, periodic knowledge checks, a quiz and an overall flow representative of user friendly online training. The goal was to build user-friendly e-learning training that could be effectively tracked in our LMS CLC. This project will continue through the next fiscal year.

Training Events

OMAO's internal leadership courses, Mid-Grade Week 1 and Week 2, fulfill the Office of Personnel Management (OPM), DOC, and NOAA requirements for new supervisor training and provide an additional cross-mission development venue for the organization. These courses, held at the National Weather Service Training Center (NWSTC), include NOAA Corps Officers, waver mariners, and civilian staff. CIRA Associate Jenna Dalton supported the leadership training as the resource manager of travel and budget, director of course logistic coordination, and course liaison.

Rapid Update Cycle (RUC) Rapid Refresh (RAP) and High-Resolution Rapid Refresh (HRRR) Models Project, Data Distribution and Visualization - B. Jamison, E. Szoke

A dual-monitor hallway display on the second floor of the David Skaggs Research Center (DSRC) displays HRRR model graphics for public viewing. Currently, a montage loop of four output fields is regularly displayed and updated automatically.

A large touchscreen kiosk monitor in the second floor atrium area has been updated with added HRRR graphic loops of composite reflectivity, precipitation and precipitation type. New, larger and more detailed images were created and are updated specifically for the kiosk.

CoCoRaHS

CoCoRaHS, the Community Collaborative Rain, Hail and Snow network (<http://www.cocorahs.org>) was founded by the Colorado Climate Center at Colorado State University. This citizen-science project started in Fort Collins, Colorado after a devastating flash flood in 1997. The flood caused over \$200 million in damages (including major damages to the CSU campus) and the loss of five lives and also pointed out the need for timely and localized precipitation data. Precipitation is known to be extremely variable; and, with the help of volunteers who are trained and equipped, the gaps between official weather stations are being supplemented by volunteer data. The network quickly grew and now consists of over 20,000 volunteers in all 50 States, Canada and Puerto Rico, U.S. Virgin Islands and The Bahamas with 10,000-12,000 reports submitted daily (Figure 6). One key to the project's success is that the data are used by the public as well as professionals including scientists and meteorologists at the National Weather Service.

CoCoRaHS has continued to produce new educational materials including animation based videos. In an effort to increase watershed education and awareness, CoCoRaHS released a new episode to their education series called “Watersheds” (Figure 7). This educational piece covers the basics of defining a watershed. It also discusses how scientists use precipitation data to predict how much water will flow into streams and rivers in your watershed. An evaluation was conducted in May 2016 by an outside firm to test the effectiveness of the Watershed animation compared to a recorded web-lecture containing the same information. It was concluded that participants’ ratings of the animations were mixed, but that the animations group scored much higher on a content knowledge assessment. Some adults found the animations were not appealing, but no definitive conclusions were drawn about whether one style is more appropriate for one particular audience. The report is available upon request.

Since 2012, CoCoRaHS piloted an effort in to reach out to schools. Initially, Colorado recruited nearly 150 schools around the state. Many of them submitted data, and even more success was realized by holding two campaigns per year called ‘Rain Gauge Week’. After the initial pilot and proven success, the model expanded to all of CoCoRaHS, and through 2016 there were over 1000 schools registered in the database with over 650 having entered data. The bi-annual ‘Rain Gauge Week’ occurs in May and September each year and has been a good way to keep enthusiasm high throughout the school year. An outside evaluator conducted a new survey in March 2016 for CoCoRaHS teachers. The results included several recommendations that are currently being implemented. The report is available upon request.

Over 450 students, teachers and members of the public were reached through events and presentations throughout 2016. These include classroom presentations, professional development for teachers and public tours of the Fort Collins Weather Station.

Through a formal partnership with NEON Citizen Science Academy in Boulder, Colorado, CoCoRaHS is a featured project for an on-line Professional Development Course for teachers seeking credit on the topic of “Introduction to Citizen Science: Explorations in Educational Settings”. CoCoRaHS has provided support for teachers in this bi-annual course since 2014. During 2016, a second course was added, “CSA 521: Using Citizen Science Data in the Classroom”, which also includes CoCoRaHS.

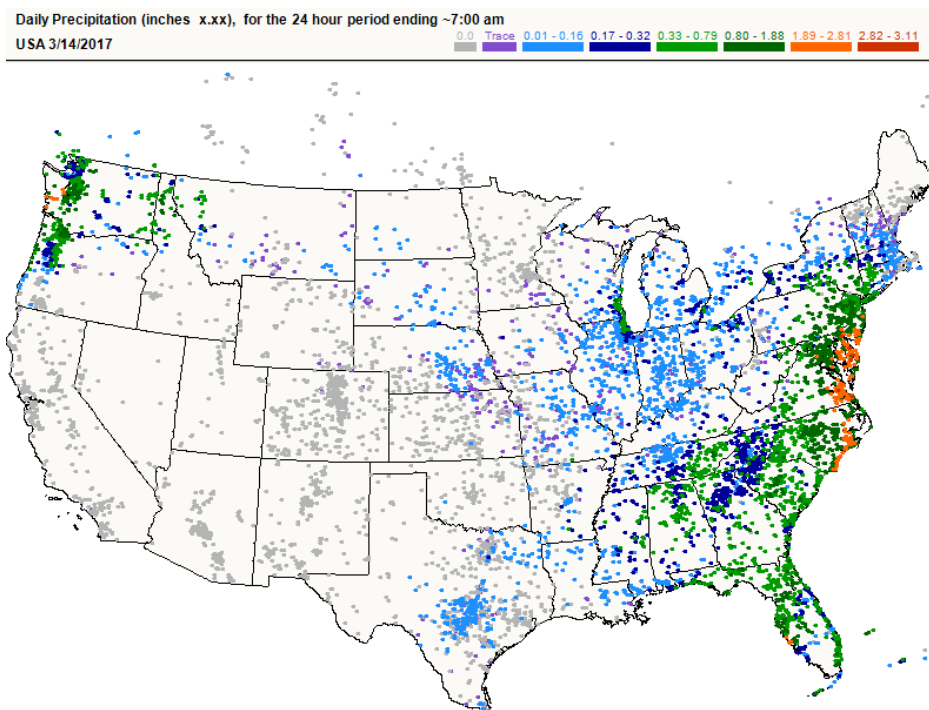

Figure 6. Current CoCoRaHS Station reporting for early 2017.



Figure 7. Video available online at <https://youtu.be/2pwW2rIGla8>

Summary

CIRA Education and Outreach initiatives continue to provide valuable education resources to the community and the Nation and will continue to develop new areas for the education effort through 2016. CIRA has developed a program to continue education on resilience for local communities and has applied for funding under the NOAA Office of Education to host workshops during 2017 and beyond to bring NOAA resources into the classroom. CIRA will continue to develop programs focusing on under-represented minorities and is looking at seeking funding for internships, pairing undergraduate students with CIRA researchers to showcase NOAA product development and operations. And as always, CIRA education efforts will continue to address evolving needs as they arise, helping to complete the goal of creating a truly weather-ready Nation.

NOAA AWARD NUMBERS FOR CIRA

Award Number	Identifier	Project Title	Principal Investigators/ Project Directors
NA14OAR4320125	Cooperative Agreement	A Cooperative Institute to Investigate Satellite Applications for Regional/Global-Scale Forecasts	Chris Kummerow (Lead), Steven Miller
NA16OAR4590233	Competitive	Accounting for Non-Gaussianity in the Background Error Distributions Associated With Cloud-related Variables (microwave radiances and hydrometeors) in Hybrid Data Assimilation for Convective-scale Prediction	Karina Apodaca
NA15OAR4590152	Competitive	Assessment of Gridded Hydrological Modeling for NWS Flash Flood Operations	L. Johnson
NA16OAR4590237	Competitive	Assimilation of Lake and Reservoir Levels into the WRF-Hydro National Water Model to Improve Operational Hydrologic Predictions	Lynn Johnson
NA16OAR4310094	Competitive	Collaborative Research: Assessing Oceanic Predictability Sources for MJO Propagation	Charlotte DeMott
NA15OAR4310099	Competitive	Development of a Framework for Process-oriented Diagnosis of Global Models	Eric Maloney
NA14OAR4310148	Competitive	Following Emissions from Non-traditional Oil and Gas Development Through Their Impact on Tropospheric Ozone	Emily Fischer, Delphine Farmer
NA16OAR4310064	Competitive	Forecasting North Pacific Blocking and Atmospheric River Probabilities: Sensitivity to Model Physics and the MJO	Elizabeth Barnes
NA16NWS4680012	Competitive	Implementation and Testing of Lognormal Humidity and Cloud-related Control Variables for the NCEP GSI Hybrid EnVar Assimilation Scheme	Steven Fletcher
NA15OAR4590200	Competitive	Improvement and Implementation of the Probability-based Microwave Ring Rapid Intensification Index for NHC/JTWC Forecast Basins	Kate Musgrave
NA15OAR4590202	Competitive	Improvement to the Tropical Cyclone Genesis Index (TCGI)	Andrea Schumacher
NA15OAR4590204	Competitive	Improvements to Operational Statistical Tropical Cyclone Intensity Forecast Models	Galena Chirokova, Andrea Schumacher
NA13OAR4310080	Competitive	Improving CarbonTracker Flux Estimates for North Americas Using Carbonyl Sulfide (OCS)	Ian Baker
NA16OAR4590238	Competitive	Improving Probabilistic Forecasts of Extreme Rainfall Through Intelligent Processing of High-resolution Ensemble Predictions	Russ Schumacher

NOAA AWARD NUMBERS FOR CIRA

NA16OAR4590215	Competitive	Improving Understanding and Prediction of Concurrent Tornadoes and Flash Floods with Numerical Models and VORTEX-SE Observations	Russ Schumacher
NA16OAR4310090	Competitive	Investigating the Underlying Mechanisms and Predictability of the MJO NAM Linkage in the NMME Phase-2 Models	Elizabeth Barnes
NA15OAR4590233	Competitive	Multi-disciplinary Investigation of Concurrent Tornadoes and Flash Floods in the Southeastern US	Russ Schumacher
NA14OAR4310141	Competitive	Observational Constraints on the Mechanisms that Control Size- and Chemistry-resolved Aerosol Fluxes Over a Colorado Forest	Delphine Farmer
NA16OAR4590230	Competitive	Quantifying Stochastic Forcing at Convective Scales	David A. Randall
NA13OAR4310103	Competitive	Research to Advance Climate and Earth System Models Collaborative Research: A CPT for Improving Turbulence and Cloud Processes in the NCEP Global Models	David Randall
NA13OAR4310077	Competitive	Towards Assimilation of Satellite, Aircraft and Other Upper-air CO2 Data into CarbonTracker	David Baker
NA13OAR4590190	Competitive	Upgrades to the Operational Monte Carlo Wind Speed Probability Program	Andrea Schumacher
NA13OAR4310163	Competitive	Use of the Ocean-Land-Atmosphere Model (OLAM) with Cloud System-resolving Refined Local Mesh to Study MJO Initiation	Eric Maloney
NA14OAR4830122	Competitive - Sandy	CIRA Assimilation of Moisture and Precipitation Observations in Cloudy Regions of Hurricane Inner Core Environments to Improve Hurricane Intensity, Structure and Precipitation	Chris Kummerow, Milija Zupanski
NA14NWS4830020	Competitive - Sandy	CIRA – Distance Learning Materials on Blended Numerical Guidance Products	Chris Kummerow, Bernie Connell
NA14NWS4830018	Competitive - Sandy	CIRA – Distance Learning Materials on Tropical Storm Forecasting and Threats	Chris Kummerow, Bernie Connell
NA14OAR4830110	Competitive - Sandy	ESRL/GSD Participation in the Establishment of a NOAA Lab Activity for OSSEs	Sher Schranz, Ning Wang
NA14OAR4830114	Competitive - Sandy	Evaluation of Earth Networks Total Lightning Products for NWS Warning Services in the Hazardous Weather Testbed	Sher Schranz
NA14NWS4830034	Competitive - Sandy	Incorporating the GOES-R Geostationary Lightning Mapper Assimilation into the GSI for Use in the NCEP Global System	Milija Zupanski, Karina Apodaca
NA14NWS4830009	Competitive - Sandy	MADIS Transition to NWS Operations	Sher Schranz, Tom Kent

NOAA AWARD NUMBERS FOR CIRA

NA14OAR4830111	Competitive - Sandy	NOAA's High Impact Weather Prediction Project (HIWPP) Test Program – Ensemble Statistical Post-processing	Sher Schranz, Isidora Jankov
NA14OAR4830109	Competitive - Sandy	NOAA's High Impact Weather Prediction Project (HIWPP) Test Program – Real-time IT Operations	Sher Schranz
NA14OAR4830112	Competitive - Sandy	NOAA's High Impact Weather Prediction Project (HIWPP) Test Program – Fine-grain Computing	Sher Schranz
NA14OAR4830113	Competitive - Sandy	NOAA's High Impact Weather Prediction Project (HIWPP) Test Program – Visualization and Extraction via NEIS	Sher Schranz
NA14OAR4830167	Competitive - Sandy	NOAA' S Observing System Experiments and Observing System Simulation Experiments in Support of the "Sensing Hazards with Operational Unmanned Technology" (SHOUT) Program – Development and Testing of Sampling Strategies for Unmanned Aerial Systems	Sher Schranz, Ning Wang
NA14OAR4830166	Competitive - Sandy	Sensing Hazards with Operational Unmanned Technology (SHOUT) – Data Management and Visualization	Sher Schranz, Jebb Stewart

VISION AND MISSION

The overarching Vision for CIRA is:

To conduct interdisciplinary research in the atmospheric sciences by entraining skills beyond the meteorological disciplines, exploiting advances in engineering and computer science, facilitating transitional activity between pure and applied research, leveraging both national and international resources and partnerships, and assisting NOAA, Colorado State University, the State of Colorado, and the Nation through the application of our research to areas of societal benefit.

Expanding on this Vision, our Mission is:

To serve as a nexus for multi-disciplinary cooperation among CI and NOAA research scientists, University faculty, staff and students in the context of NOAA-specified research theme areas in satellite applications for weather/climate forecasting. Important bridging elements of the Institute include the communication of research findings to the international scientific community, transition of applications and capabilities to NOAA operational users, education and training programs for operational user proficiency, outreach programs to K-12 education and the general public on environmental literacy, and understanding and quantifying the societal impacts of NOAA research.

CIRA Organizational Structure

January 2017

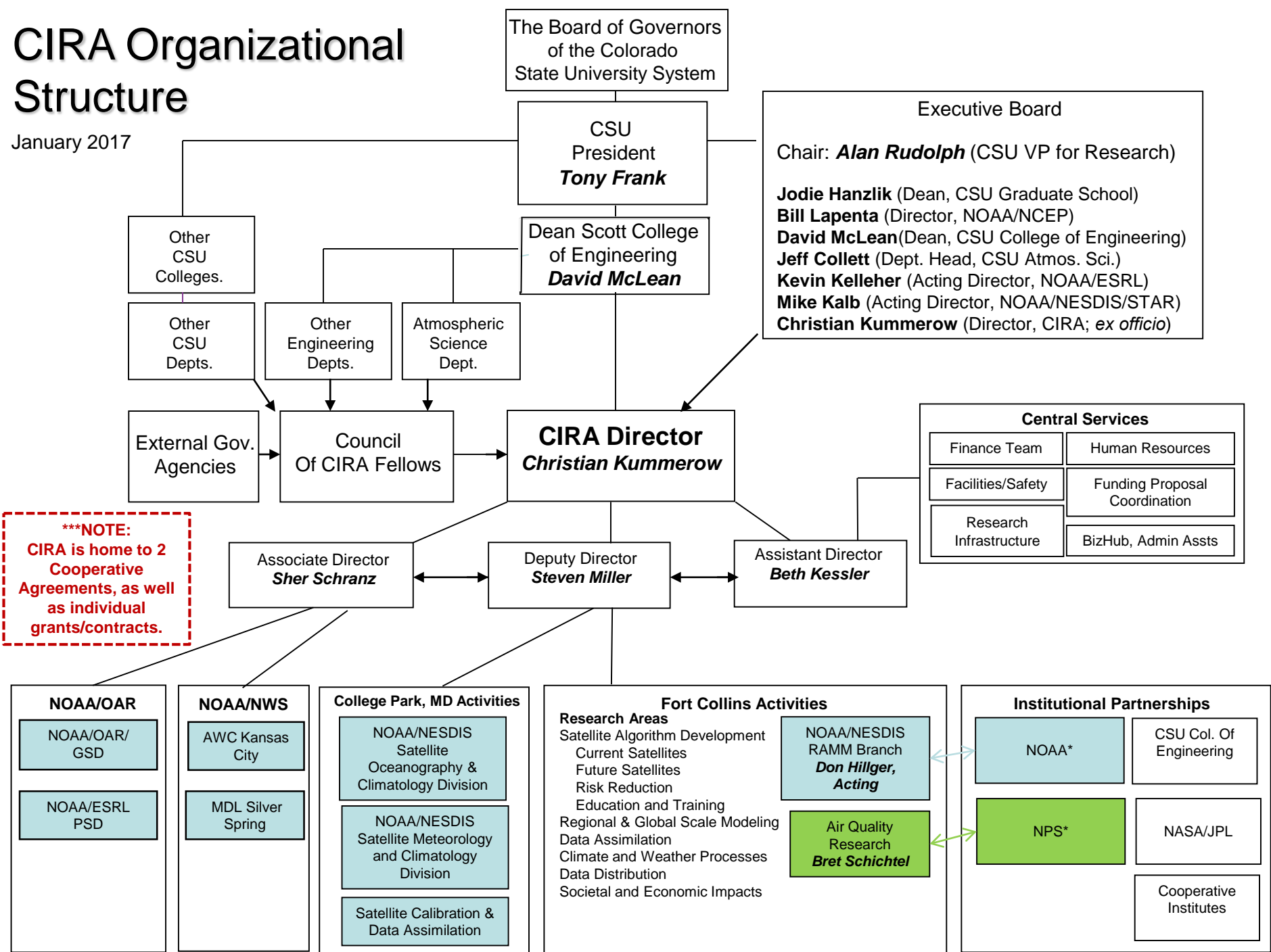

EXECUTIVE SUMMARY—Research Highlights

The Cooperative Institute for Research in the Atmosphere (CIRA) at Colorado State University (CSU) serves as both an active collaborator and formal interface between academic expertise and multiple agencies holding both basic and applied research interests in atmospheric science. Under its capacity as NOAA's Cooperative Institute for exploiting satellite applications for improvements in regional and global-scale forecasting, CIRA provides an important and practical connection between two NOAA line offices—Oceanic and Atmospheric Research (OAR) and the National Environmental Satellite, Data and Information Service (NESDIS). Diverse expertise in satellite remote sensing, science algorithm and application development, education/training, regional/global weather and climate modeling, data assimilation, and data distribution technology make CIRA a valuable asset to NOAA in terms of transitioning research concepts to operational stakeholders.

Outside of the core group in Fort Collins, CIRA's collaborations with the Global Systems Division (GSD), the Physical Sciences Division (PSD), and the Global Monitoring Division (GMD) of the NOAA Earth System Research Lab (ESRL) in Boulder continue to be strong. Technical and scientific leadership is evident in work with the High Resolution Rapid Refresh Model HRRR and HRRR/Chem, as well as GSI Data Assimilation systems that provide the best possible model initialization fields. Likewise, CIRA research continues to expand in the areas of quality assessment of NWS and FAA products relevant to turbulence forecasting. Key research and development positions are held by CIRA researchers in programs that focus on the delivery and visualization of NOAA's data to research, operational and public users. Major projects include the NOAA Earth Information System (NEIS), the NWS AWIPS II Hazard Services, FxCAGE virtual client systems, the Meteorological Assimilation and Data Ingest System (MADIS), the NWS Virtual Laboratory (VLab), and the Integrated Dissemination Program (IDP). CIRA researchers are also leaders in the development of high-performance computing software and firmware (especially related to GPU processing). CIRA researchers lead and contribute to the development of technology and scientific content for NOAA's premier education and outreach program, Science on a Sphere (SOS®).

The CIRA Annual Report provides summaries of the contributions emerging from our research partnership with NOAA, with more detail to be found in the peer-reviewed and technical conference publications cited within this report as appropriate. Highlighted below are accomplishments from the current reporting period and drawn from both the NOAA reports contained herein as well as from the broader palette of research conducted at CIRA. Organized by CIRA's research themes, these examples underscore intra- and inter-agency partnerships that present opportunities for leveraging activities of other agencies.

Satellite Algorithm Development, Training and Education

- With GOES-16 now in orbit, and JPSS about to follow, much of the core focus in the satellite algorithm development and training work has focused on these two sensors. The GOES-16 risk reduction, in particular, has a number of elements designed to prepare the community for the new data products, improve the prediction of tropical cyclone genesis, understand its structure and changes in structure leading to improved predictions of both track and intensity forecasts using the enhanced GOES-16 capabilities. Images made from JMA's Himawari-8 proved useful in that CIRA was able to immediately release stunning imagery from GOES-16 that were used in nearly every first-light image shown by NASA and NOAA. This however is simply a prelude to new multi-spectral products being developed at CIRA. An example of this is the detection of lofted dust in a visually intuitive graphical display that bears direct relevance to the challenges of visibility hazards forecasting - a particular hazard for aviation weather and CIRA's work with the Aviation Weather Center. Another important aspect of this project which is near completion is the synthetic imagery that uses cloud model output to extend the satellite radiances and thus provides an important tool for combining models and observations in a unique way that allows forecasters to assess forecast model quality by examining the continuity of the observed cloud fields as they loop from the present (observations) to the future (models).

- The imagery work related to GOES-16 also has a strong Tropical Cyclone component that seeks to aid forecasters with the interpretation of cloud-top microphysics from the imagery, improve the statistical inference of TC structures from Infrared Imagery and anticipate the TC eye formation. Using HWRF winds coupled with the synthetic imagery described above allowed the TC group to develop relationships between IR structures and TC winds. While not completed, early results are encouraging. These advances are further coupled to a strong program in education and training activities such as CIRA's participation in the Virtual Institute for Satellite Integration Training (VISIT), the Satellite Hydro-Meteorological training and education activity (SHyMET), and the International Virtual Laboratory (VLab)
- An area of great excitement continues to be the work being done with the Day/Night band of Suomi-NPP in preparation for JPSS. Not only is detection of smoke, dust, and fog possible at night but these new results have generated a lot of excitement in the community. Much work was done in this previous year related to quantifying the arctic winter clouds that are often difficult to detect with infra-red methods alone. The VIIRS Sensor is also being used extensively to estimate tropical cyclone intensity and structure, as well as for more established applications related to Sea Surface Temperature and Ocean Color products produced by CIRA Research Scientists working directly with NOAA StAR employees in College Park, MD. Perhaps not evident when evaluating a single proposal, however, is the synergy that CIRA provides across projects through its internal communications and collaborations. A careful review of all the activities related to satellite algorithm development, training and education, however, clearly reveals these synergies and the benefits that these create on behalf of NOAA.
- A new area is the work being performed jointly by CIRA staff in Fort Collins with GSD staff in Boulder to connect GOES-16 with rapid-update numerical forecast models for advanced short-term prediction and data fusion capabilities. This effort hopes to exploit very high-resolution GOES-16 data to assimilate cloud location and latent heat release into GSD's HRRR model at 5- and possibility even 1-minute intervals over limited domains.

NOAA Regional to Global Scale Model Research

- CIRA researchers took the lead in several technical and modeling programs within the Ensemble Model research activities continuing within the Developmental Testbed Center (DTC), the Aviation Weather Testbed (AWT) and the Hydro Met Testbed (HMT). CIRA researchers implemented changes to the HWRF workflow ROCOTO code to allow multiple storm information into the model. Research continued to address what impact dynamic core adjustments have on the uncertainty in the NARRE (North American Rapid Refresh Ensemble) model. To improve seasonal and long-range forecasts, research has begun on the use of stochastic physics into large-scale models within the HRRR framework.
- Project management, technical leadership and scientific research for the High Impact Weather Prediction Project (HIWPP), part of the Hurricane Sandy Supplemental funding work, continued in 2016. Project reporting for this program is performed on a quarterly basis, with monthly updates provided during status phone calls. Four of the nine GSD SS projects have been completed with final reports submitted to OAR. Research in OSSEs, high performance computing, information systems, global models, and model verification will be completed in 2017.
- CIRA researchers conducted the research and software development required to transition the Graphical Turbulence Guidance, v3 (GTG3) algorithms into NOAA's Global Ensemble Forecast System (GEFS). The new version of GEFS with the GTG3 algorithms became operational in November 2016. Research was also conducted to improve the global Eddy Dissipation Rate (EDR) and to evaluate the effects of model resolution on global aviation weather forecast algorithm results.

- CIRA researchers continue to provide scientific and technical leadership to the Flow Following Finite Icosahedral Model (FIM) development program. CIRA research focused on improving stochastic parameter schemes to improve forecast skill. Work continued to develop high performance computing algorithms needed to execute this very large modeling system and methods required to diagnose and resolve atmospheric phenomenon using the FIM system.
- The NGGPS program required a focus on running the FV3 model to improve pre and post-processing of the native cubed sphere grid. CIRA researchers have developed software to produce output files on a standard Cartesian grid.

Data Assimilation

- Our Data Assimilation theme showcases developments of Ensemble Data Assimilation for Hurricane Forecasting as well as specific applications of these techniques with GOES data. While perhaps not completely evident from this report that focuses on accomplishments related to our NOAA grants, the Data Assimilation activity benefits tremendously from other funding sources that spur the theoretical innovation that is then applied to existing NOAA problems such as CO₂ data assimilation within NOAA's CarbonTracker program or the hybrid Variational-Ensemble Kalman Filter approach used to assimilate Lightning data

Climate and Weather Processes

- Much of this effort centered on getting better soil moisture using precipitation data from CIRA's "Citizen Science" project, enhancing NIDIS drought monitoring and early warning in the Upper Colorado River Basin, as well as improving drought and precipitation recurrence intervals from models and observations.

NOAA Data Distribution Research

- Significant research and development work was conducted by CIRA researchers to continue the improvement and extension of the AWIPS II software suite. Systems developed and in the process of being transitioned to operations are: Forecast Decision Support Environment (FDSE) tools, LAPS and MSAS migration to AWIPS II servers, Automated Test Framework (ATF), TAF and Forecast Text formatters, Hazard Services (aviation, winter weather, hurricane storm surge, severe weather forecast probabilities) and the FxCAGE thin client.
- As part of the NWS NextGen Aviation Weather Program, CIRA researchers at ESRL continued their research into the technology and science of populating a four-dimensional airspace with atmospheric data, extraction methodologies, distribution formats, and input mechanisms to be used by aviation decision support systems. Using the AWT, real-time aviation weather forecast products and decision support tools that utilize verification information in a real-time, web-based tool (INSITE) are being developed for a transition to operations. Working with NOAA and CIRA Subject Matter Experts (SMEs) in the NWS Integrated Distribution Program, an automated process to create Product Description Documents (PDD's) is improving aviation weather data management and dissemination to the FAA, NWS and private enterprise partners. CIRA research efforts continue to provide OGC compliant weather and iWXXM observation data prototyping in the format required by the international aviation weather community, including the transition of software to NOAA data providers and aviation weather users.

- The MADIS (Meteorological Assimilation Data Ingest System) successfully upgraded the operational system in the NCEP Central Operations (NCO) with new Department of Transportation data, Hydromet and Flood warning system data. Significant development was begun on the NextGen IT Web Services (NGITWS) capability. The system has become an operational component of the NWS NCEP via the Integrated Dissemination Program (IDP).
- Via Sandy Supplemental and other NOAA programs, CIRA researchers have continued technical leadership and development of the NOAA Environmental Information System (NEIS). This capability relies on Unity3D, software that has traditionally been used for 3D video games, to present high-volume datasets in stunning displays. Important to the success of the NEIS system is the ability to manage and distribute real-time, global, high-resolution geophysical data. No other geophysical data system has the capabilities of NEIS. NEIS has been chosen as the primary method to distribute forecast model data from the High Impact Weather Prediction Project (HIWPP). In 2016 the technology was advanced to allow users dynamic control of overlays, remote real-time data retrieval, and 4D-volume data exploration.
- The on-going partnership with the NWS Meteorological Development Lab continued on several fronts: CIRA researcher's program and technical leadership to the Virtual Lab (VLab), the AutoNowCaster (ANC), Impacts Catalog, the Weather Information Statistical Post Processing System (WISPS), updating the Model Output Statistics (MOS) system, making updates to the MDL Map Viewer, updates to the Local Climate Analysis Tool (LCAT), and the continued development of NWS data delivery via Web Services. VLab is now a required component in the transition of research to operations for the NWS AWIPS II program. VLab Development Services, established, developed and maintained by the CIRA research team, has grown over 100% and now supports over 400 projects and 2300 developers. The CIRA research team members led the design and development of the new Project Repository used by VLab developers to improve AWIPS II software and develop decision support tools.
- CIRA researchers continued close collaborations with research and operations personnel at the Aviation Weather Testbed at the NWS Aviation Weather Center in Kansas City, MO. Primary goals of the partnership are to actively engage in the research-to-operations process and to develop, test, and evaluate new and emerging scientific techniques, products, and services in support of the aviation weather community. Aviation Weather Research Program (AWRP) research and development efforts have been centered in three research areas: 1) Aviation Impact Variables (AIVs) which are tested during the AWC Summer and Winter Aviation Weather Experiments and include the development of the Collaborative Aviation Weather Statement (CAWS), and the development of International global turbulence algorithm development, 2) NWS NextGen aviation weather data format prototyping for international standards, and efficient data and product distribution via the Integrated Dissemination Program (IDP) and the web and 3) AWIPS II decision support systems transition to operations.
- NextGen: CIRA researchers and software engineers at the AWC have led the effort to develop the data format standards and web services methods to disseminate forecast information and the web display capabilities required for visualization of distributed data.

Our Outreach Program efforts continue to provide key technical and scientific leadership for the Science On a Sphere (SOS®) Program. While maintaining the continued production and delivery of real-time global weather models, researchers have developed additional real-time datasets including STEREO spacecraft data and the HIWPP global models. 16 new SOS systems were installed around the globe this year, bringing the total number of systems to over 130. Research was conducted to radically improve the SOS visual resolution by using a 4K projector. A NOAA/GSD Director's Fund Award was given to the SOS team to develop new higher resolution (8k) data sets for the Sphere. While not funded, CIRA is also preparing to distribute high resolution image loops that were very popular with Japan's Himawari-8 and promise to be even more popular with our own GOES-16 satellite.

Over the past year the CIRA group working with the National Park Service (NPS) continued its research on issues related to visibility and air quality at our Nation's National Parks. Their research, while focused on issues of importance to the National Park Service, overlaps considerably with a number of new CIRA initiatives related to pollutant transport such as those related to fires that are of great interest to the Park Service and NOAA and thus continues to be an integral partner in what we do as CIRA.

The CloudSat Mission continues to enjoy strong support from NASA despite some anomalies with the spacecraft during the previous year. The CloudSat program, with its Data Processing Center running operationally at CIRA on behalf of NASA, has facilitated multiple research activities that are of benefit to NOAA. Chief among these is CIRA's ability to quickly make use of the CloudSat data to provide a unique validation for cloud base height retrievals produced by the VIIRS instrument on Suomi-NPP. A new effort to provide the algorithms and products for NASA's recently approved GeoCarb mission also offers the opportunity to more closely collaborate with GMD in its carbon tracking efforts.

Interspersed among these major research themes are important contributions from CIRA's NESDIS postdoctoral and young researcher program in data distribution, assimilation, and satellite algorithm development. Located in College Park, MD, and integrated closely with NOAA technical contacts at StAR, these scientists are immersed in research ranging from refinements to the Community Radiative Transfer Model (CRTM), data assimilation of cloudy radiances, satellite-based sea surface temperature (SST) algorithm development, techniques for monitoring and quality control of long-term SST records, and ocean color algorithm development for global climate and coastal/in-land water ecosystem monitoring. Some of the techniques and web interfaces being developed by this outstanding group of Research Scientists is a constant reference source for other CIRA activities with similar objectives.

This Annual Report is the eighth in a series to be completed under CIRA's Cooperative Agreement established with NOAA. With this third report in the second 5-year lifecycle of the Cooperative Institute, we re-establish our commitment to the maintenance and growth of a strong collaborative relationship among NOAA, the Atmospheric Science Department at CSU, Departments of the University, and the other major programs within CIRA. As we pursue continued alignment with NOAA's Strategic Research Guidance Memorandum and NOAA's research themes, we look forward to the challenges and rewards for helping NOAA achieve its goals of understanding and predicting changes in climate, weather, oceans and coasts.

CIRA Task II Spending by Theme

April 1, 2016 through March 31, 2017

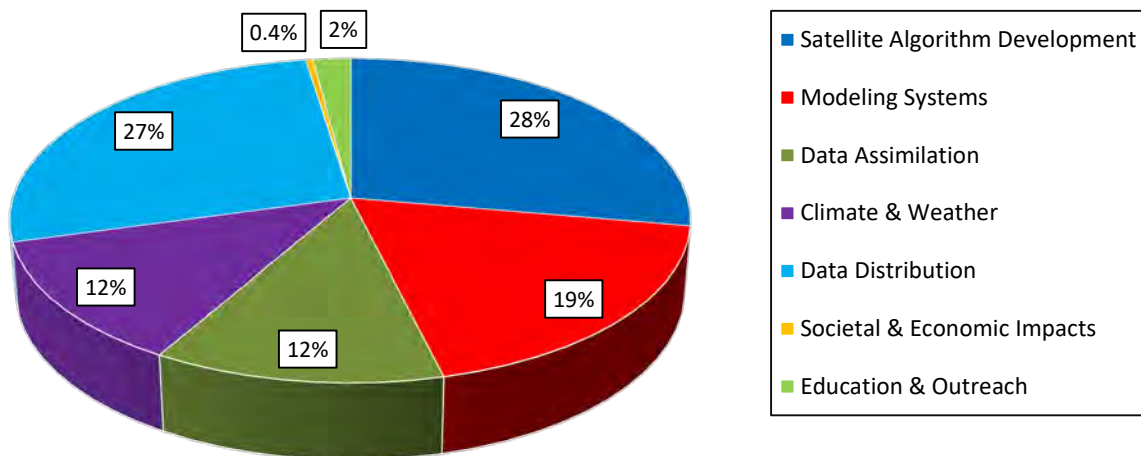

CIRA BOARD, COUNCIL, FELLOWS & BOARD MEETINGS

CIRA EXECUTIVE BOARD

Jeff Collett, Colorado State University
Department Head, Atmospheric Science
Jodie Hanzlik, Colorado State University
Dean, Graduate School
Harry Cikanek, NOAA
Acting Director, NOAA/NESDIS/STAR
Kevin Kelleher, NOAA
Acting Director, ESRL
Christian Kummerow (ex officio), Colorado State University
Director, CIRA and Professor of Atmospheric Science
David McLean, Colorado State University
Dean, Engineering
Alan Rudolph, Colorado State University
Vice President for Research

CIRA COUNCIL OF FELLOWS

V. Chandrasekar, Colorado State University
Department of Electrical and Computer Engineering
Michael Farrar, NOAA
Director Environmental Modeling Center NOAA/NCEP
Don Hillger, Colorado State University
Acting Chief, NOAA/NESDIS/RAMM Branch
Satya Kalluri, NOAA
Chief CoRP, NOAA/STAR
Sonia Kreidenweis-Dandy, Colorado State University
Professor, Department of Atmospheric Science
Christian Kummerow, Colorado State University
Director, CIRA and Professor of Atmospheric Science
Anthony Mostek, NOAA
Branch Chief, Forecast Decision Training Division, NOAA/NWS
Joshua Scheck, NOAA
Chief Aviation Support Branch, NOAA Aviation Weather Center
John Schneider, NOAA
Chief, ESRL/GSD/Technology Outreach Branch
Pieter Tans, NOAA
Senior Scientist, Climate Monitoring and Diagnostics Lab
Fuzhong Weng, NOAA
Chief, NESDIS/STAR/Satellite Calibration and Data Assimilation Branch

CIRA FELLOWS

Mahmood Azimi-Sadjadi, Electrical & Computer Engineering, CSU
Daniel Birkenheuer, NOAA/ESRL/GSD
V. Chandrasekar, Electrical & Computer Engineering, CSU
Jeffrey Collett, Jr., Atmospheric Science Department, CSU
William Cotton, Atmospheric Science Department, CSU
Mark DeMaria, NOAA/NWS/NHC
Scott Denning, Atmospheric Science Department, CSU
Mike Farrar, Director Environmental Modeling Center NOAA/NCEP
Steven, Fassnacht, Ecosystem Science and Sustainability, CSU
Graham Feingold, NOAA/ESRL
Douglas Fox, Senior Research Scientist Emeritus, CIRA, CSU, USDA (Retired)
Jay Ham, Soil and Crop Sciences, CSU
Scott Hausman, NOAA/GSD
Richard Johnson, Atmospheric Science Department, CSU
Andrew Jones, Senior Research Scientist, CIRA, CSU
Pierre Y. Julien, Civil Engineering, CSU
Stanley Kidder, Senior Research Scientist, CIRA, CSU
Sonia Kreidenweis, Atmospheric Science Department, CSU
Christian Kummerow, CIRA Director, Atmospheric Science Department, CSU
Glen Liston, Senior Research Scientist, CIRA, CSU
Alexander "Sandy" MacDonald, NOAA
William Malm, Senior Research Scientist, CIRA; National Park Service (retired)
Steven Miller, CIRA Deputy Director, CSU
Anthony Mostek, Branch Chief, Forecast Decision Training Division, NOAA/NWS
Chris O'Dell, Senior Research Scientist, CIRA, CSU
Roger Pielke, Sr., Senior Research Scientist, CIRES, U of Colorado
James Purdom, Senior Research Scientist, CIRA, CSU
Robert Rabin, NOAA/National Severe Storms Laboratory
Steven Rutledge, Atmospheric Science Department, CSU
Joshua Scheck, Chief Aviation Support Branch, NOAA Aviation Weather Center
John Schneider, Chief, ESRL/GSD/Technology Outreach Branch
Tim Schneider, Office of Hydrologic Development NOAA/GSD
George Smith, Riverside Technologies
Graeme Stephens, JPL and Atmospheric Science Department, CSU
Pieter Tans, NOAA/CMDL
Thomas Vonder Haar, CIRA Director Emeritus and Atmospheric Science Department, CSU
Fuzhong Weng, NOAA/NESDIS/STAR
Milija Zupanski, Senior Research Scientist, CIRA

Scheduled Meetings:

2016/17 Meeting of the CIRA Council – May 9, 2017

2016/17 Meeting of the CIRA Executive Board – June 15, 2017

TASK I – A COOPERATIVE INSTITUTE TO INVESTIGATE SATELLITE APPLICATIONS FOR REGIONAL/GLOBAL-SCALE FORECASTS

Task I activities are related to the administrative management of the CI. As reflected in the pie chart appearing earlier in this report, expenses covered by Task I are primarily salary and benefits, annual report production costs and some travel. This task also includes some support of postdoctoral and visiting scientists.

SEMINARS SUPPORTED BY TASK I

April 1, 2016, P. Gogineni (University of Kansas). Radar Instrumentation for Remote Sensing of Ice, Snow, and Soil Moisture.

April 8, 2016, G. McFarquhar (University of Illinois). Use of In-situ Observations for Quantifying Ice Cloud Microphysical Properties and Processes, and Their Uncertainties.

April 15, 2016, D.J. Jacob (Harvard). Quantifying Methane Emissions in North America Using Satellites.

April 22, 2016, K. Barsanti (Center for Environmental Research and Technology). Exploring Chemical Complexity in Biomass Burning Emissions and Air Quality Models.

April 29, 2016, S.M. Cavallo (University of Oklahoma). Linking Arctic to Lower Latitude Processes Through Resilient Tropopause-based Vortices.

May 6, 2016, T.C. Peterson (WMO Commission for Climatology). The Story of Climate Data.

June 24, 2016, C. Eldred (University of Paris). A Hydrostatic Primitive Equation Model Using Mixed Finite Elements.

July 28, 2016, L. Jiang, X. Liu, S. Son (CIRA/College Park). VIIRS Ocean Color Products.

August 22, 2016, N. Klingaman (University of Reading). The Madden-Julian Oscillation in the Super-parameterized CAM: Air-sea Interactions and the Role of ENSO.

August 26, 2016, S. Powell (CSU). Clouds, Kelvin Waves, and Convective Onset in the Madden-Julian Oscillation.

August 29, 2016, J.H. Kim (Postdoc Candidate). Exploring Clouds with Numerical Models and Satellite Observations.

August 30, 2016, J-H. Kim (NWS Aviation Weather Center, Kansas City). Global Aviation Turbulence Technique and Research.

September 2, 2016, R. A. Anthes (UCAR), T. Rieckh (University of Graz), S. Gilpin (UCAR). Contributions of Radio Occultation to Weather and Climate Using the World's Most Accurate and Precise Thermometer from Space.

September 6, 2016, M. Marchand (Postdoc Candidate). Expanding the Utility of GOES-R with the Assimilation of Lightning and Cloud Top Height Observations.

September 8, 2016, M. Petty (CIRA Boulder). Aviation Weather Decision Support.

September 9, 2016, J.B. Jensen (NCAR/EOL/RAF). Some Problems at the Foundation of Aerosol-cloud Interactions in Climate Models.

September 12, 2016, S. Miller (Stanford University). Sources of Methane Emissions in North America.

September 16, 2016, G. Pfister and F. Flocke (NCAR). The Air You Breathe: An Overview and Early Results from the Front Range Air Pollution and Photochemistry Experiment (FRAPPE).

September 19, 2016, Y. Li (Chinese Academy of Sciences). Molecular Corridors and Global Maps of Phase State in Atmospheric Secondary Organic Aerosols.

September 23, 2016, K. Grise (CSU ATS Alumnus). Do Mid-latitude Jet Shifts Cause Cloud Feedbacks?

September 30, 2016, F. Carr (University of Oklahoma). Can the U.S. Become the World Leader in Numerical Weather Prediction?

October 3, 2016, J.P. Burrows (University of Bremen). Assessing the Impact of the Anthropocene on Atmospheric Composition Using Remote Sensing from Aircraft and Space Based Instrumentation: The SCIAMACHY Project and Its Legacy.

October 7, 2016, G. Keppel-Aleks (University of Michigan). Quantifying Carbon Cycle Feedbacks through the Lens of Atmospheric CO₂ Variations.

October 14, 2016, B. Karcher (DLR, Germany). Homogeneous Ice Formation in Supercooled Water Clouds.

October 20, 2016, K. Ito (University of the Ryukyus). Recent Research and Development in Japan to Improve Typhoon Forecasts.

October 21, 2016, B. Medeiros (NCAR). The Role of Shallow Cumulus in the Climate System, and Asking How Bad is “Good Enough” for Climate Models.

October 24, 2016, B. Brown (CSU/ATS). Modifications to a Partially Double Moment Microphysics Parameterization for Hurricane Simulations.

October 28, 2016, P. Stier (Oxford University). Observational Constraints on Global Aerosol-cloud Interactions.

November 7, 2016, B. White (Oxford University). Wide-variability in Simulated Convective Microphysical Response to CDNC Highlights the Ongoing Need for Observational Constraints on Aerosol-convection Interactions.

November 9, 2016, J. Purdom (Retired RAMMB Branch Chief). Challenges Facing Us with a Generational Change in Operational Satellites – A Conversation.

November 11, 2016, K. Karnauskas (University of Colorado). Atlantic Hurricanes and Outgoing Longwave Radiation Over Africa: From Seasonal Predictions to Climate Change Projections.

November 18, 2016, P. Hitchcock (NCAR). Downward Influence from the Stratosphere in the Extratropics.

December 2, 2016, W-K Tao (NASA Goddard). The Impact of Mesoscale Convective Systems on Global Precipitation: A Modeling Study.

January 20, 2017, J. Peters (CSU Postdoc). Pressure Perturbations in Cumulus Convection.

February 3, 2017, A. Kren (CIRA Boulder). Sensing Hazards with Operational Unmanned Technology (SHOUT) project.

February 3, 2017, J. Mace (University of Utah). Seasonal Variability of Warm Boundary Layer Cloud and Precipitation Properties in the Southern Ocean as Diagnosed from A-Train and Ship-Based Remote Sensing Data.

February 10, 2017, D.J. Gagne (NCAR). Deep Machine Learning for High-impact Weather Forecasting.

February 17, 2017, Z. Wang (University of Wyoming). Recent Advances in University of Wyoming King Air Observation Capabilities.

February 23, 2017, N. Jeevanjee (Princeton). Mean Precipitation Change from Invariant Radiative Cooling.

March 2, 2017, C. Chiu (University of Reading). Using Remote Sensing Observations to Advance Understanding of Cloud-aerosol-precipitation-radiation Interactions.

March 6, 2017, A. Donohoe (University of Washington). Energetic Constraints on Global Climate.

March 7, 2017, R. Rios-Berrios (SUNY Albany). Tropical Cyclone Intensification Under Moderate Vertical Wind Shear.

March 9, 2017, K. Bossert (GATS, Inc.). Remote Sensing of the Atmosphere from the Troposphere to the Edge of Space.

March 24, 2017, E. Fleishman (CSU, Fish, Wildlife and Conservation Biology). Measuring and Interpreting Faunal Responses to Climate in the Intermountain West.

March 30, 2017, P. Jan van Leeuwen (University of Reading). Improving Geophysical System Understanding and Modelling by Exploring Nonlinear Data Assimilation.

CIRA Task I Expenses by Activity

April 1, 2016 through March 31, 2017

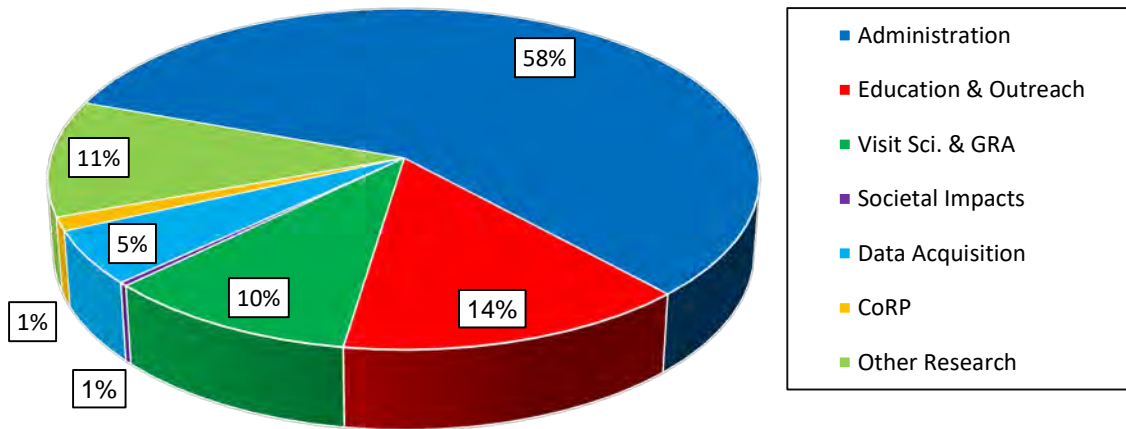

TABLE OF CONTENTS

INTRODUCTION

Director's Message	ii
Institute Description and Core Activities	iii
Education, Training and Outreach	iv
NOAA Award Numbers	xiv
Vision and Mission	xvii
Organizational Structure	xviii
Executive Summary	xix
Task and Theme Pie Chart	xxiv
Board, Council, Fellows	xxv
Task I Report and Pie Chart	xxvii
Table of Contents	xxxii

NOAA AWARD NUMBERS AND AMENDMENTS FOR REPORT PROJECTS	1
--	----------

AWARDS ENDING PROJECT LIST	15
-----------------------------------	-----------

RESEARCH THEME REPORTS	16
-------------------------------	-----------

APPENDICES:

Publications Summary Matrix	330
Employee Matrix	331
Other Agency Awards	332
Projects by Title and Page Number	336
Competitive Project List and Reports	339

NOAA AWARD NUMBERS & AMENDMENTS FOR REPORT PROJECTS

Type	ID	Title	Status
Award Package	2478931	A Cooperative Institute to Investigate Satellite Applications for Regional/Global-Scale Forecasts (NA14OAR4320125)	Accepted
Special Award Condition Report	2478931	Special Award Condition Report	
Award File 0	2478815	A Cooperative Institute to Investigate Satellite Applications for Regional/Global-Scale Forecasts	Accepted
Award File 1	2486219	Blended Hydrometeorological Products	Accepted
Award File 2	2487155	CIRA support: Getting Ready for NOAA's Advanced Remote Sensing Programs	Accepted
Award File 3	2488641	A Satellite Hydro-Meteorology (SHyMet) Education and Outreach Proposal CIRA Support for the JPSS Proving Ground and Risk Reduction Program: Application of JPSS Imagers and Sounders to Tropical Cyclone Track and Intensity Forecasting	Accepted
Award File 4	2491422	A Cooperative Institute to Investigate Satellite Applications for Regional/Global-Scale Forecasts	Accepted
Award File 5	2489188	CIRA Support of NOAA's commitment to the Coordination Group for Meteorological Satellites: Enhancing the International Virtual Laboratory	Accepted
Award File 6	2495512	A Cooperative Institute to Investigate Satellite Applications for Regional/Global-Scale Forecasts	Accepted
Award File 7	2488558	CIRA Support to the JPSS Proving Ground and Risk Reduction Program: Seeing the Light: Exploiting VIIRS Day/Night Band	Accepted
Award File 8	2489265	CIRA Support of the Virtual Institute for Satellite Integration Training (VISIT)	Accepted
Award File 9	2488553	SSMI and SSMIS Fundamental Climate Data Record Sustainment and Maintenance	Accepted
Award File 10	2489670	Algorithm development for AMSR-2	Accepted
Award File 11	2489691	Weather Satellite Data and Analysis Equipment and Support for Research Activities	Accepted
Award File 12	2489082	CIRA Support for Feature-Based Validation of MIRS Soundings for Tropical Cyclone Analysis and Forecasting	Accepted
Award File 13	2489686	Support for the 2015 JCSDA Summer Colloquium to be hosted by CIRA	Accepted
Award File 14	2489681	Applications of concurrent super rapid sampling from GOES-14 SRSOR, radar and lightning data	Accepted

NOAA AWARD NUMBERS & AMENDMENTS FOR REPORT PROJECTS

Award File 15	2486813	CIRA Support to a GOES-R Proving Ground for National Weather Service Forecaster Readiness	Accepted
Award File 16	2486808	CIRA Support for Tropical Cyclone Model Diagnostics and Product Development	Accepted
Award File 17	2488603	CIRA Support to the JPSS Science Program: S-NPP VIIRS EDR Imagery Algorithm and Validation Activities and S-NPP VIIRS Cloud Validation	Accepted
Award File 18	2489060	CIRA Support for Research and Development for GOES-R Risk Reduction for Mesoscale Weather Analysis and Forecasting	Accepted
Award File 19	2496525	A Cooperative Institute to Investigate Satellite Applications for Regional/Global-Scale Forecasts	Accepted
Award File 20	2495520	CIRA Support to the NESDIS Cooperative Research Exchange Program	Accepted
Award File 21	2497195	A Cooperative Institute to Investigate Satellite Applications for Regional/Global-Scale Forecasts	Accepted
Award File 22	2497181	A Cooperative Institute to Investigate Satellite Applications for Regional/Global-Scale Forecasts	Accepted
Award File 23	2496807	A Cooperative Institute to Investigate Satellite Applications for Regional/Global-Scale Forecasts	Accepted
Award File 24	2495693	EOY CIRA Support to RAMMB Infrastructure for GOES-R Rebroadcast Data Collection at CIRA/CSU	Accepted
Award File 25	2496490	NESDIS Environmental Applications Team (NEAT)	Accepted
Award File 26	2496040	Explicit Forecasts of Recurrence Intervals for Rainfall: Evaluation and Implementation Using Convection-allowing Models	Accepted
Award File 27	2495157	Building a "citizen science" soil moisture monitoring system utilizing the Community Collaborative Rain, Hail and Snow Network (CoCoRaHS)	Accepted
Award File 28	2496378	Estimating Peatland Fire Emissions Using Nighttime Satellite Data	Accepted
Award File 29	2496383	Integrating GPM and Orographic Lifting into NOAA's QPE in Mountainous Terrain	Accepted
Award File 30	2495162	Instructional Development and Learning Support for NOAA's OMAO's Chief Learning Officer (CLO), OMAO Kansas City, Missouri	Accepted
Award File 31	2465060	CIRA Research Collaborations with the NWS Meteorological Development Lab on Virtual Laboratory, Innovation Web Portal, and AWIPS II Projects	Accepted
Award File 32	2490588	CIRA Research Collaborations with the NWS Meteorological Development Lab on Virtual Laboratory, and AWIPS II Projects	Accepted
Award File 33	2491622	Environmental Applications Research (EAR)	Accepted

NOAA AWARD NUMBERS & AMENDMENTS FOR REPORT PROJECTS

Award File 34	2491359	Research Collaboration at the NWS Aviation Weather Center in Support of the Aviation Weather Testbed, Aviation Weather Research Program, and the NextGen Weather Program	Accepted
Award File 35	2496023	Hydrologic and Water Resources Research and Applications Outreach	Accepted
Award File 36	2501944	A Cooperative Institute to Investigate Satellite Applications for Regional/Global-Scale Forecasts	Accepted
Award File 37	2514836	Research Collaboration at the NWS Aviation Weather Center in Support of the Aviation Weather Testbed, Aviation Weather Research Program, and the NextGen Weather Program	Accepted
Award File 38	2513184	Environmental Applications Research (EAR)	Accepted
Award File 39	2515553	A Cooperative Institute to Investigate Satellite Applications for Regional/Global-Scale Forecasts	Accepted
Award File 40	2522402	Environmental Applications Research (EAR)	Accepted
Award File 41	2523066	Research Collaboration at the NWS Aviation Weather Center in Support of the Aviation Weather Testbed, Aviation Weather Research Program, and the NextGen Weather Program	Accepted
Award File 42	2524140	A Cooperative Institute to Investigate Satellite Applications for Regional/Global-Scale Forecasts	Accepted
Award File 43	2526318	Environmental Applications Research (EAR)	Accepted
Award File 44	2534850	SSMI and SSMIS Fundamental Climate Data Record Sustainment and Maintenance	Accepted
Award File 45	2534835	Weather Satellite Data and Analysis Equipment and Support for Research Activities	Accepted
Award File 46	2527895	Hydrometeorological and Water Resources Research	Accepted
Award File 47	2528844	CIRA Support to a GOES-R Proving Ground for National Weather Service Forecaster Readiness	Accepted
Award File 48	2537730	Environmental Applications Research (EAR)	Accepted
Award File 49	2529388	Blended Hydrometeorological Products	Accepted
Award File 50	2539333	Applications of concurrent super rapid sampling from GOES-14 SRSOR, radar and lightning data	Accepted
Award File 51	2534840	CIRA Support to RAMMB Infrastructure for GOES-R Rebroadcast Data Collection at CIRA/CSU	Accepted
Award File 52	2537750	CIRA Support for Research and Development for GOES-R Risk Reduction for Mesoscale Weather Analysis and Forecasting	Accepted
Award File 53	2534845	CSU/CIRA support for ATMS SI traceable calibration effort	Accepted
Award File 54	2541040	Instructional Development and Learning Support for NOAA's OMAO's Chief Learning Officer (CLO), OMAO Kansas City, Missouri	Accepted

NOAA AWARD NUMBERS & AMENDMENTS FOR REPORT PROJECTS

Award File 55	2545352	Environmental Applications Research (EAR)	Accepted
Award File 56	2544741	Environmental Applications Research (EAR)	Accepted
Award File 57	2537745	CIRA Support to the JPSS Proving Ground and Risk Reduction Program: Seeing the Light: Exploiting VIIRS Day/Night Band	Accepted
Award File 58	2543413	Expanding precipitation measurements in the Commonwealth Of The Bahamas through the CoCoRaHS (Community Collaborative Rain, Hail and Snow) network	Accepted
Award File 59	2538448	JCSDA Observing System Assessment Standing Capability	Accepted
Award File 60	2539540	Enhancing NIDIS drought monitoring and early warning in the Upper Colorado River basin	Accepted
Award File 61	2540022	CIRA Support: Getting Ready for NOAA's Advanced Remote Sensing Programs. A Satellite Hydro-Meteorology (SHyMet)	Accepted
Award File 62	2543403	Tropical Cyclone Model Diagnostics and Product Development	Accepted
Award File 63	2547742	Hydrometeorological and Water Resources Research	Accepted
Award File 64	2539141	CIRA Support to the JPSS STAR Science Program: S-NPP VIIRS EDR Imagery Algorithm and Validation Activities	Accepted
Award File 65	2546014	NESDIS Environmental Applications Team (NEAT)	Accepted
Award File 66	2543660	CIRA Support to the JPSS Proving Ground and Risk Reduction Program: Integration of JPSS Experimental Products in AWIPS II through EPDT Code Sprints	Accepted
Award File 67	2543675	CIRA Support to the JPSS Proving Ground and Risk Reduction Program: Improving NUCAPS Soundings for CONUS Severe Weather Applications via Data Fusion	Accepted
Award File 68	2543655	CIRA Support to the JPSS Proving Ground and Risk Reduction Program: Improving Tropical Cyclone Forecast Capabilities Using the JPSS Data Suite	Accepted
Award File 69	2543408	CIRA Support for Dynamical Core Selection for the Next Generation Global Prediction System (NGGPS)	Accepted
Award File 70	2543842	CIRA Support to the JPSS Proving Ground and Risk Reduction Program: JPSS Satellite Training for NOAA Users	Accepted
Award File 71	2546556	CIRA Support to the JPSS Proving Ground and Risk Reduction Program: Addressing NWS Desires for a Cloud Cover Layers Product using Merged VIIRS and ATMS Products	Accepted
Award File 72	2542195	CIRA Support of Virtual Institute for Satellite Integration Training (VISIT)	Accepted

NOAA AWARD NUMBERS & AMENDMENTS FOR REPORT PROJECTS

Award File 73	2543680	Using JPSS Retrievals to Implement a Multisensor, Synoptic, Layered Water Vapor Product for Forecasters	Accepted
Award File 74	2548421	CIRA Support to the NESDIS Cooperative Research Exchange Program	Accepted
Award File 75	2547800	CIRA Research Collaborations with the NWS Meteorological Development Lab on Virtual Laboratory, and AWIPS II Projects	Accepted
Award File 76	2551024	CIRA Research Collaborations with the NWS Meteorological Development Lab on Virtual Laboratory, and AWIPS II Projects	Accepted
Award File 77	2548825	CIRA Support for Feature-Based Validation of MIRS Soundings for Tropical Cyclone Analysis and Forecasting	Accepted
Award File 78	2549707	NESDIS Environmental Applications Team (NEAT)	Accepted
Award File 79	2551561	A Cooperative Institute to Investigate Satellite Applications for Regional/Global-Scale Forecasts	Accepted
Award File 80	2539242	Research Collaboration at the NWS Aviation Weather Center in Support of the Aviation Weather Testbed	Accepted
Award File 81	2546546	EOY StAR Project: CIRA Support to RAMMB Infrastructure for GOES-R Rebroadcast Data Collection at CIRA/CSU	Accepted
Award File 82	2546551	CIRA Support of NOAA's commitment to the Coordination Group for Meteorological Satellites: Enhancing the International Virtual Laboratory	Accepted
Award File 83	2564667	Environmental Applications Research (EAR)	Accepted
Award File 84	2567423	Environmental Applications Research (EAR)	Accepted
Award File 85	2571981	A Cooperative Institute to Investigate Satellite Applications for Regional/Global-Scale Forecasts	Accepted
Award File 86	2573606	Hydrometeorological and Water Resources Research	Accepted
Award File 87	2571970	Research Collaboration at the NWS Aviation Weather Center in Support of the Aviation Weather Testbed	Accepted
Award File 88	2583141	Environmental Applications Research (EAR)	Accepted
Award File 89	2582313	Hydrometeorological and Water Resources Research	Accepted
Award File 90	2586202	Hydrologic and Water Resources Research and Applications Outreach	Accepted
Award File 91	2590615	A Cooperative Institute to Investigate Satellite Applications for Regional/Global-Scale Forecasts	Accepted
Award File 92	2590552	CIRA Support to the JPSS Proving Ground and Risk Reduction Program: Cold Air Aloft Aviation Hazard Detection Using Observations from the JPSS Satellites and Application to the Visualization of Grid	Accepted
Award File 93	2590936	CIRA Support of NOAA's commitment to the Coordination Group for Meteorological Satellites: Enhancing the International Virtual Laboratory	Accepted

NOAA AWARD NUMBERS & AMENDMENTS FOR REPORT PROJECTS

Award File 94	2590927	A Cooperative Institute to Investigate Satellite Applications for Regional/Global-Scale Forecasts	Accepted
Award File 95	2590873	CIRA Support for the Organization of the 2016 Group for High Resolution Sea Surface Temperature Science Team Meeting	Accepted
Award File 96	2590953	A Cooperative Institute to Investigate Satellite Applications for Regional/Global-Scale Forecasts	Accepted
Award File 97	2596628	A Cooperative Institute to Investigate Satellite Applications for Regional/Global-Scale Forecasts	Accepted
Award File 98	2590603	Using JPSS Retrievals to Implement a Multisensor, Synoptic, Layered Water Vapor Product for Forecasters	Accepted
Award File 99	2590917	CIRA Support to the JPSS Proving Ground and Risk Reduction Program: JPSS Satellite Training for NOAA Users	Accepted
Award File 100	2596693	CIRA Research Collaborations with the NWS Meteorological Development Lab on Virtual Laboratory, and AWIPS II Projects	Accepted
Award File 101	2596624	Enhancing NIDIS drought monitoring and early warning in the Upper Colorado River basin	Accepted
Award File 102	2591332	CIRA Support to the JPSS Proving Ground and Risk Reduction Program: Improving Tropical Cyclone Forecast Capabilities Using the JPSS Data Suite	Accepted
Award File 103	2599072	A Cooperative Institute to Investigate Satellite Applications for Regional/Global-Scale Forecasts	Accepted
Award File 104	2599068	CIRA Support to the JPSS Proving Ground and Risk Reduction Program: Integration of JPSS Experimental Products in AWIPS II through EPDT Code Sprints	Accepted
Award File 105	2600008	Instructional Development and Learning Support for NOAA's OMAO's Chief Learning Officer (CLO), OMAO Kansas City, Missouri	Accepted
Award File 106	2600014	A Cooperative Institute to Investigate Satellite Applications for Regional/Global-Scale Forecasts	Accepted
Award File 107	2591167	POES-GOES Blended Hydrometeorological Products	Accepted
Award File 108	2597117	CIRA Support to a GOES-R Proving Ground for National Weather Service Forecaster Readiness and Training	Accepted
Award File 109	2599057	MiRS High-Resolution Snow and Ice Products	Accepted
Award File 110	2597540	CSU/CIRA Support for ATMS SI Traceable Calibration Effort	Accepted
Award File 111	2590545	Weather Satellite Data and Analysis Equipment and Support for Research Activities	Accepted
Award File 112	2590540	CIRA Support to the JPSS STAR Science Program: S-NPP VIIRS EDR Imagery Algorithm and Validation Activities and S-NPP VIIRS Cloud Validation	Accepted
Award File 113	2590530	CIRA Support to the JPSS Proving Ground and Risk Reduction Visiting Scientist Program	Accepted

NOAA AWARD NUMBERS & AMENDMENTS FOR REPORT PROJECTS

Award File 114	2601311	Supplemental CIRA Support of the Virtual Institute for Satellite Integration Training (VISIT)	Accepted
Award File 115	2597127	ATMS Precipitable Water Algorithms and Products (MIRS)	Accepted
Award File 116	2599819	CIRA Support to the JPSS Proving Ground and Risk Reduction Program: Improving NUCAPS Soundings for CONUS Severe Weather Applications via Data Fusion	Accepted
Award File 117	2599824	CIRA Support to the JPSS Proving Ground and Risk Reduction Program: Addressing NWS Desires for a Cloud Cover Layers Product using Merged VIIRS and ATMS Products	Accepted
Award File 118	2599845	MiRS ATMS Rain-Rate and Total Precipitable Water Algorithm and Product Development	Accepted
Award File 119	2603556	Environmental Applications Research (EAR)	Accepted
Award File 120	2602575	CIRA Support to Connecting GOES-R with Rapid-Update Numerical Forecast Models for Advanced Short-Term Prediction and Data Fusion Capabilities	Accepted
Award File 121	2597513	Community Radiative Transfer Model Development and Maintenance	Accepted
Award File 122	2608626	Environmental Applications Research (EAR)	Accepted
Award File 123	2608669	Environmental Applications Research (EAR)	Accepted
Award File 124	2599838	CIRA Support for Development and Evaluation of JPSS-1 based Tropical Cyclone Intensity and Structure Estimates	Accepted
Award File 125	2601306	CIRA Support for Research and Development for GOES-R Risk Reduction for	Accepted
Award File 126	2610128	Mesoscale Weather Analysis and Forecasting and Training Applications of concurrent super rapid sampling from GOES-14 SRSOR, radar and lightning data	Accepted
Award File 127	2608614	Research Collaboration at the NWS Aviation Weather Center in Support of	Accepted
Award File 128	2612445	the Aviation Weather Testbed, Aviation Weather Research Program, and the NextGen Weather Program NESDIS Environmental Applications Team (NEAT)	Accepted
Award File 129	2598905	CIRA Support to the JPSS Proving Ground and Risk Reduction Program: In Pursuit of the Shadows: VIIRS Day/Night Band Research Enabling Scientific Advances and Expanded Operational Awareness of the Nocturnal Environment	Accepted
Award File 130	2614084	Hydrometeorological and Water Resources Research	Accepted
Award File 131	2609956	CIRA Research Collaborations with the NWS Meteorological Development Lab	Accepted

NOAA AWARD NUMBERS & AMENDMENTS FOR REPORT PROJECTS

Award File 132	2601317	CIRA Support for Tropical Cyclone Model Diagnostics and Product Development	Accepted
		Research Collaboration at the NWS Aviation Weather Center in Support of	Accepted
Award File 133	2617473	the Aviation Weather Testbed, Aviation Weather Research Program, and the NextGen Weather Program	
Award File 134	2633736	Environmental Applications Research (EAR)	Accepted
		Research Collaboration at the NWS Aviation Weather Center in Support of	Accepted
Award File 135	2635566	the Aviation Weather Testbed, Aviation Weather Research Program, and the NextGen Weather Program	
		Research Collaboration at the NWS Aviation Weather Center in Support of the Aviation Weather Testbed, Aviation Weather Research Program, and the NextGen	Accepted
Award File 136	2638062	Weather Program	
Type	ID		Status
Award Package	2614337	Accounting for Non-Gaussianity in the Background Error Distributions Associated with Cloud-related Variables (NA16OAR4590233)	Accepted
Special Award Condition Report	2614337	Special Award Condition Report	
Award File 0	2611931	Accounting for Non-Gaussianity in the Background Error...	Accepted
Type	ID		Status
Award Package	2545573	Assessment of Gridded Hydrological Modeling for NWS Flash Flood Operations (NA15OAR4590152)	Accepted
Special Award Condition Report	2545573	Special Award Condition Report	
Award File 0	2542326	Assessment of Gridded Hydrological Modeling for NWS Flash Flood Operations	Accepted
Award File 1	2603148	Assessment of Gridded Hydrological Modeling for NWS Flash Flood Operations	Accepted

NOAA AWARD NUMBERS & AMENDMENTS FOR REPORT PROJECTS

Type	ID		Status
Award Package	2614326	Assimilation of Lake and Reservoir Levels into the WRF-Hydro National Water Model to Improve Operational Hydrologic Predictions (NA16OAR4590237)	Accepted
Special Award Condition Report	2614326	Special Award Condition Report	
Award File 0	2611956	Assimilation of Lake and Reservoir Levels into the WRF-Hydro National Water Model to Improve Operational Hydrologic Predictions	Accepted

Type	ID		Status
Award Package	2603839	Collaborative Research: Assessing Oceanic Predictability Sources for MJO Propagation (NA16OAR4310094)	Accepted
Special Award Condition Report	2603839	Special Award Condition Report	
Award File 0	2590660	Collaborative Research: Assessing Oceanic Predictability Sources for MJO Propagation	Accepted

Type	ID		Status
Award Package	2538850	Development of a Framework for Process-Oriented Diagnosis of Global Models (NA15OAR4310099)	Accepted
Special Award Condition Report	2538850	Special Award Condition Report	
Award File 0	2538327	Development of a Framework for Process-Oriented Diagnosis of Global Models	Accepted
Award File 1	2582795	Development of a Framework for Process-Oriented Diagnosis of Global Models	Accepted

Type	ID		Status
Award Package	2494494	Following Emissions from Non-Traditional Oil and Gas Development Through their Impact on Tropospheric Ozone (NA14OAR4310148)	Accepted
Special Award Condition Report	2494494	Special Award Condition Report	
Award File 0	2481822	Following Emissions from Non-Traditional Oil and Gas Development Through their Impact on Tropospheric Ozone	Accepted
Award File 1	2523977	Following Emissions from Non-Traditional Oil and Gas Development Through their Impact on Tropospheric Ozone	Accepted
Award File 2	2562067	Following Emissions from Non-Traditional Oil and Gas Development Through their Impact on Tropospheric Ozone	Accepted

NOAA AWARD NUMBERS & AMENDMENTS FOR REPORT PROJECTS

Type	ID		Status
Award Package	2603816	Forecasting North Pacific Blocking and Atmospheric... (NA160AR4310064)	Accepted
Special Award Condition Report	2603816	Special Award Condition Report	
Award File 0	2590675	Forecasting North Pacific Blocking and Atmospheric...	Accepted

Type	ID		Status
Award Package	2608726	Implementation and Testing of Lognormal Humidity and Cloud-related Control Variables for the NCEP GSI Hybrid EnVar Assimilation Scheme (NA15NWS4680012)	Accepted
Special Award Condition Report	2608726	Special Award Condition Report	
Award File 0	2600908	Implementation and testing of lognormal humidity and cloud-related control variables for the NCEP GSI hybrid EnVar assimilation scheme	Accepted

Type	ID		Status
Award Package	2547897	Improvement and Implementation of the Probability-based Microwave Ring Rapid Intensification Index for NHC/JTWC Forecast Basins (NA15OAR4590200)	Accepted
Special Award Condition Report	2547897	Special Award Condition Report	
Award File 0	2545713	Improvement and Implementation of the Probability-based Microwave Ring Rapid Intensification Index for NHC/JTWC Forecast Basins	Accepted
Award File 1	2606671	Improvement and Implementation of the Probability-based Microwave Ring Rapid Intensification Index for NHC/JTWC Forecast Basins	Accepted

NOAA AWARD NUMBERS & AMENDMENTS FOR REPORT PROJECTS

Type	ID		Status
Award Package	2548857	Improvement to the Tropical Cyclone Genesis Index (TCGI) (NA15OAR4590202)	Accepted
Special Award Condition Report	2548857	Special Award Condition Report	
Award File 0	2545733	Improvement to the Tropical Cyclone Genesis Index (TCGI)	Accepted
Award File 1	2606709	Improvement to the Tropical Cyclone Genesis Index (TCGI)	Accepted

Type	ID		Status
Award Package	2547895	Improvements to Operational Statistical Tropical Cyclone Intensity Forecast Models (NA15OAR3590204)	Accepted
Special Award Condition Report	2547895	Special Award Condition Report	
Award File 0	2545703	Improvements to Operational Statistical Tropical Cyclone Intensity Forecast Models	Accepted
Award File 1	2605978	Improvements to Operational Statistical Tropical Cyclone Intensity Forecast Models	Accepted

Type	ID		Status
Award Package	2442452	Improving CarbonTracker Flux Estimates for North America using Carbonyl Sulfide (OCS) (NA13OAR4310080)	Accepted
Special Award Condition Report	2442452	Special Award Condition Report	
Award File 0	2428639	Improving CarbonTracker Flux Estimates for North America using Carbonyl Sulfide (OCS)	Accepted
Award File 1	2472074	Improving CarbonTracker Flux Estimates for North America using Carbonyl Sulfide (OCS)	Accepted
Award File 2	2523613	Improving CarbonTracker Flux Estimates for North America using Carbonyl Sulfide (OCS)	Accepted

NOAA AWARD NUMBERS & AMENDMENTS FOR REPORT PROJECTS

Type	ID		Status
Award Package	2614345	Improving Probabilistic Forecasts of Extreme Rainfall through Intelligent Processing of High-resolution Ensemble Predictions (NA16OAR4590238)	Accepted
Special Award Condition Report	2614345	Special Award Condition Report	
Award File 0	2611891	Improving probabilistic forecasts of extreme rainfall through intelligent processing of high-resolution ensemble predictions	Accepted

Type	ID		Status
Award Package	2612424	Improving Understanding and Prediction of Concurrent Tornadoes and Flash Floods with Numerical Models and VORTEX-SE Observations (NA16OAR4590215)	Accepted
Special Award Condition Report	2612424	Special Award Condition Report	
Award File 0	2611614	Improving understanding and prediction of concurrent tornadoes and flash floods with numerical models and VORTEX-SE observations	Accepted

Type	ID		Status
Award Package	2603828	Investigating the Underlying Mechanisms and Predictability of the MJO NAM Linkage in the NMME Phase-2 Models (NA16OAR4310090)	Accepted
Special Award Condition Report	2603828	Special Award Condition Report	
Award File 0	2590690	Investigating the Underlying Mechanisms and Predictability of the MJO NAM Linkage in the NMME Phase-2 Models	Accepted

Type	ID		Status
Award Package	2551491	Multi-disciplinary Investigation of Concurrent Tornadoes and Flash Floods in the Southeastern US (NA15OAR45900233)	Accepted
Special Award Condition Report	2551491	Special Award Condition Report	
Award File 0	2550317	Multi-disciplinary investigation of concurrent tornadoes and flash floods in the Southeastern US	Accepted

NOAA AWARD NUMBERS & AMENDMENTS FOR REPORT PROJECTS

Type	ID		Status
Award Package	2495278	Observational Constraints on the Mechanisms that Control Size- and chemistry-resolved Aerosol Fluxes Over a Colorado Forest (NA14OAR4310141)	Accepted
Special Award Condition Report	2495278	Special Award Condition Report	
Award File 0	2481792	Observational constraints on the mechanisms that control size- and chemistry-resolved aerosol fluxes over a Colorado forest	Accepted
Award File 1	2523653	Observational constraints on the mechanisms that control size- and chemistry-resolved aerosol fluxes over a Colorado forest	Accepted
Award File 2	2562129	Observational constraints on the mechanisms that control size- and chemistry-resolved aerosol fluxes over a Colorado forest	Accepted

Type	ID		Status
Award Package	2614341	Quantifying Stochastic Forcing at Convective Scales (NA16OAR4590230)	Accepted
Special Award Condition Report	2614341	Special Award Condition Report	
Award File 0	2611921	Quantifying Stochastic Forcing at Convective Scales	Accepted

Type	ID		Status
Award Package	2445121	Research to Advance Climate and Earth System Models Collaborative Research: A CPT for Improving Turbulence and Cloud Processes in the NCEP Global Models (NA13OAR4310103)	Accepted
Special Award Condition Report	2445121	Special Award Condition Report	
Award File 0	2437060	Research to Advance Climate and Earth System Models Collaborative Research: A CPT for Improving Turbulence and Cloud Processes in the NCEP Global Models	Accepted
Award File 1	2479399	Research to Advance Climate and Earth System Models Collaborative Research: A CPT for Improving Turbulence and Cloud Processes in the NCEP Global Models	Accepted

NOAA AWARD NUMBERS & AMENDMENTS FOR REPORT PROJECTS

Award File 2	2526839	Research to Advance Climate and Earth System Models Collaborative Research: A CPT for Improving Turbulence and Cloud Processes in the NCEP Global Models	Accepted
Award File 3	2582947	Research to Advance Climate and Earth System Models Collaborative Research: A CPT for Improving Turbulence and Cloud Processes in the NCEP Global Models	Accepted

Type	ID		Status
Award Package	2437319	Towards Assimilation of Satellite, Aircraft, and Other Upper-air CO2 Data into CarbonTracker (NA13OAR4310077)	Accepted
Special Award Condition Report	2437319	Special Award Condition Report	
Award File 0	2428619	Towards Assimilation of Satellite, Aircraft, and Other Upper-air CO2 Data into CarbonTracker	Accepted
Award File 1	2464196	Towards Assimilation of Satellite, Aircraft, and Other Upper-air CO2 Data into CarbonTracker	Accepted
Award File 2	2526909	Towards Assimilation of Satellite, Aircraft, and Other Upper-air CO2 Data into CarbonTracker	Accepted

Type	ID		Status
Award Package	2445809	Use of the Ocean-Land-Atmosphere Model (OLAM) with Cloud System-Resolving Refined Local Mesh to Study MJO Initiation (NA13OAR43110163)	Accepted
Special Award Condition Report	2445809	Special Award Condition Report	
Award File 0	2441730	Use of the Ocean-Land-Atmosphere Model (OLAM) with Cloud System-Resolving Refined Local Mesh to Study MJO Initiation.	Accepted
Award File 1	2487251	Use of the Ocean-Land-Atmosphere Model (OLAM) with Cloud System-Resolving Refined Local Mesh to Study MJO Initiation.	Accepted

AWARDS ENDING PROJECT LIST

NA12OAR4310077	Competitive	Intraseasonal to Interannual Variability in the Intra-Americas Sea in Climate Models	Eric Maloney
NA13OAR4590190	Competitive	Upgrades to the Operational Monte Carlo Wind Speed Probability Program	Andrea Schumacher
NA14NWS4830018	Competitive - Sandy	CIRA – Distance Learning Materials on Tropical Storm Forecasting and Threats	Chris Kummerow, Bernie Connell
NA14NWS4830020	Competitive - Sandy	CIRA – Distance Learning Materials on Blended Numerical Guidance Products	Chris Kummerow, Bernie Connell
NA14NWS4830034	Competitive - Sandy	Incorporating the GOES-R Geostationary Lightning Mapper Assimilation into the GSI for Use in the NCEP Global System	Milija Zupanski, Karina Apodaca
NA14OAR4830109	Competitive - Sandy	NOAA's High Impact Weather Prediction Project (HIWPP) Test Program – Real-time IT Operations	Sher Schranz
NA14OAR4830110	Competitive	CIRA Participation in the Establishment of a NOAA Laboratory Activity for Observing System Simulation Experiments (OSSEs)	Sher Schranz
NA14OAR4830111	Competitive - Sandy	NOAA's High Impact Weather Prediction Project (HIWPP) Test Program – Ensemble Statistical Post-processing	Sher Schranz, Isidora Jankov
NA14OAR4830112	Competitive - Sandy	NOAA's High Impact Weather Prediction Project (HIWPP) Test Program – Fine-grain Computing	Sher Schranz
NA14OAR4830113	Competitive - Sandy	NOAA's High Impact Weather Prediction Project (HIWPP) Test Program – Visualization and Extraction via NEIS	Sher Schranz
NA14OAR4830114	Competitive - Sandy	Evaluation of Earth Networks Total Lightning Products for NWS Warning Services in the Hazardous Weather Testbed	Sher Schranz
NA14NWS4830009	Competitive	MADIS Transition to NWS Operations (A)	Sher Schranz

RESEARCH THEME REPORTS

Satellite Algorithm Development, Training and Education NOAA Goal 2: Weather Ready Nation	17
Regional to Global-scale Modeling Systems NOAA Goal 2: Weather Ready Nation	192
Data Assimilation NOAA Goal 2: Weather Ready Nation	212
Climate-Weather Processes NOAA Goal 3: Climate Adaptation and Mitigation	225
Data Distribution NOAA Goal 5: NOAA Enterprise-wide Capabilities: Science and Technology Enterprise, Engagement Enterprise, Organization and Administration Enterprise	264

SATELLITE ALGORITHM DEVELOPMENT, TRAINING & EDUCATION

Research associated with development of satellite-based algorithms for weather forecasting, with emphasis on regional and mesoscale meteorological phenomenon. This work includes applications of basic satellite products such as feature track winds, thermodynamic retrievals, sea surface temperature, etc., in combination with model analyses and forecasts, as well as in situ and other remote sensing observations. Applications can be for current or future satellites. Also under this theme, satellite and related training material will be developed and delivered to a wide variety of users, with emphasis on operational forecasters. A variety of techniques can be used, including distance learning methods, web-based demonstration projects and instructor-led training.

PROJECT TITLE: Applications of Concurrent Super Rapid Sampling from GOES-14 SRSOR, Radar and Lightning Data

PRINCIPAL INVESTIGATORS: Steve Albers, Sher Schranz

RESEARCH TEAM: Steve Albers

NOAA TECHNICAL CONTACT: Bob Rabin (NOAA/NSSL)

NOAA RESEARCH TEAM (The equivalent of CIRA Research Team for NOAA Staff involved in the project and their affiliations):

FISCAL YEAR FUNDING: \$26,100

PROJECT OBJECTIVE:

Test the impact of GOES Super-Rapid Scan (SRSOR) Atmospheric Motion Vectors (AMVs) in a high resolution analysis and forecasting system. We are focusing on the 09 May 2016 case of tornadic thunderstorms in south central Oklahoma.

PROJECT ACCOMPLISHMENTS:

A retrospective LAPS analysis and forecast run was conducted for May 9, 2016 to further evaluate the impact of rapid update AMV data. We are examining fields such as wind and divergence at various altitudes in relation to evolving convective features. To do this we relocalized our 1-km resolution domain over the Southern Plains states and performed the run on the NOAA HPCS Theia computer.

The analysis part of the output between 1800UTC and 2100UTC has been copied over to our virtual machine for evaluation. We are starting to examine wind and related fields in two runs, one with AMV data added and one without. To do this our web-based viewer will be staged on a new locally available web server.

PROJECT TITLE: ATMS Precipitable Water Algorithms and Products - Blended-Hydromet Products Validation

PRINCIPAL INVESTIGATOR: John Forsythe

RESEARCH TEAM: Stan Kidder, Andy Jones

NOAA TECHNICAL CONTACT: Limin Zhao (NOAA/NESDIS/OSPO)

NOAA RESEARCH TEAM: Limin Zhao (NOAA/NESDIS/OSPO)
and Ralph Ferraro (NOAA/NESDIS/STAR)

FISCAL YEAR FUNDING: \$56,977

PROJECT OBJECTIVES:

This project began in August 2016 and has the goals of monitoring and validating the NESDIS operational blended rain rate (BRR) and blended total precipitable water (TPW) products. In this year, the focus is on S-NPP and GCOM-W products, but the blended products use many satellite sensors in polar and geostationary orbits as well as surface-based GPS. Therefore, the final blended products are also monitored as a whole, as this is what forecasters see. Supporting NESDIS to ensure timely delivery of high-quality blended satellite hydrometeorology products to forecasters is the overall goal of the project.

PROJECT ACCOMPLISHMENTS:

A near-real time ingest of surface-based Global Positioning System (TPW) data at CIRA was initiated in November January 2017 via the NOAA Meteorological Assimilation Data Ingest System (MADIS). This process required approval from NOAA. GPS TPW is a backbone data set and serves both as a high quality validation source (uncertainty of < 1mm or ~ 2%) and also as the major component of the blended TPW product over CONUS. Most GPS stations are over land, but there are a few on offshore oil rigs and small isolated islands in the Caribbean which are useful for validation of the ocean-only GCOM-W1 TPW retrievals. Surface-based GPS TPW is considered the gold standard for TPW validation. A new decoder for this data was created and delivered to NOAA OSPO in Fall 2016.

The Algorithm Theoretical Basis Documents (ATBDs) for operational blended rain rate and blended TPW were updated by CIRA and delivered to OSPO. These updates were much needed as the previous update was in 2011, and much of the sensor constellation and retrieval package had changed. The new ATBD's now reflect the state of the blended products as of October 2016. GCOM-W1 and S-NPP ATMS inputs and orbital information are now included.

CIRA has collaborated with the Cooperative Institute for Climate Studies (CICS) to add blended rain rate to a near-real time product monitoring tool. This tool (<http://cics.umd.edu/ipwg/index.html>) is under the umbrella of a much larger effort via the International Precipitation Working Group, and compares several different precipitation products. NOAA BRR product comparisons to the (Multi-Radar/Multi-Sensor System) MRMS rain rate product are available at <http://cics.umd.edu/pmeyers/brr/> and http://cics.umd.edu/pmeyers/brr/threshold_analysis/. A science question still being explored is how to reconcile differing spatial resolution of satellites and the particular validation needs of forecasters versus other researchers.

Publications: None

PROJECT TITLE: CIRA Support to Connecting GOES-R with Rapid-Update Numerical Forecast Models for Advanced Short-term Prediction and Data Fusion Capabilities

PRINCIPAL INVESTIGATOR: Chris Kummerow

RESEARCH TEAM: Kyle Hilburn, Max Marchand, Steven D. Miller

NOAA TECHNICAL CONTACT: Satya Kalluri (NOAA/NESDIS)
and Steve Goodman (NOAA/NESDIS/GOESR Program)

NOAA RESEARCH TEAM: Dan Lindsey (NOAA/NESDIS/STAR/RAMMB),
Stephen Weygandt and Curtis Alexander (NOAA/OAR/ESRL)

FISCAL YEAR FUNDING: \$200,000

PROJECT OBJECTIVES:

The ultimate goal of the project is to use the high space/time resolution imagery from GOES-16 (ABI and GLM) to improve the initialization of convection in RAP/HRRR and improve short-term forecasts of high impact weather events and weather hazards. Anticipated downstream improvements to the distribution, timing, and interactions of convection bear high relevance to fire weather and severe storm development, including better representation of outflow impacts and interactions within complex multi-cellular storm environments.

PROJECT ACCOMPLISHMENTS:

During this initial spin-up year, we spent time getting oriented with the HRRR model and understanding its current data assimilation scheme. This involved consolidation of observation/modeling tools and alignment of NOAA/CIRA research partnerships. More specifically, the work addressed the following milestones, discussed further below.

1-- (a) Configure model for initial testing of convective information. (b) Install HRRR locally, and work with developers from Stan Benjamin's group.

2-- (a) Examine techniques for advancing convective initialization in HRRR. (b) Examine lightning/precipitation-core space/time relationships.

3-- (a) Research bounded derivative and other techniques effective for cloud initialization. (b) Prepare model to accept perturbed environmental state at observation-prescribed locations.

4-- Examine techniques for initializing downbursts in HRRR, collaborating with Ken Pryor on satellite-based parameterizations.

1a--In order to configure the HRRR model for initial testing, it was essential to establish a research partnership with the HRRR developers at NOAA ESRL. Our first meeting occurred at ESRL on 11 May 2016 for Kyle Hilburn and Chris Kummerow to introduce themselves and the project to Steven Weygandt and Ming Hu. Phone calls during the summer kept the lines of communication open before the next major meeting at ESRL on 14 September 2016. This meeting included Steve Weygandt, Curtis Alexander, and others from ESRL, and was the first opportunity for Steve Miller and Dan Lindsey to meet the ESRL collaborators. Kyle Hilburn attended a meeting on 27 October 2016 to learn the practical details of re-compiling and running HRRR on the NOAA supercomputer Theia using the Rocoto workflow management software. An important achievement, prerequisite for running HRRR, is obtaining a NOAA CAC and account on Theia. This process involves several steps and takes several months, and Kyle Hilburn received his CAC, the final step of the process, on 3 March 2017. Kyle and Max have also setup

a project account on the newly available Summit High Performance Computer system, a joint activity of Colorado State University and University of Colorado Boulder, supported by the National Science Foundation.

1b--While HRRR can only be run on a supercomputer, a limited-area version of HRRR has been run locally at CIRA. The same model configuration and physics as HRRR are used, but fewer datasets are assimilated and a smaller spatial domain is used to make simulations computationally tractable. Running this simple version of RAP/HRRR involves two software packages: the weather forecast model (WRF) and the data assimilation system (GSI). Early in the project, Kyle Hilburn met with Milija Zupanski at CIRA on a weekly basis to learn about running GSI and how to modify GSI for new data sources and new assimilation techniques. Since time on the supercomputer is extremely limited, the locally run version of HRRR is a crucial tool for testing GOES-16 data assimilation techniques before attempting to implement them in the full version of HRRR.

2a--Examination of techniques for advancing convective initialization into HRRR has involved quantifying the information content in high resolution imagery collected by GOES-14 in SRSOR mode and in the MRMS 3-D reflectivity fields currently used by HRRR to initialize convection. Figure 1 provides a flowchart for the HRRR data assimilation system, which shows that the first step is assimilation of radar reflectivity observations at 15-minute intervals during the pre-forecast hour. This is the primary pathway for initializing convection in HRRR, and could be targeted with ABI and/or GLM observations. Based on our comparisons of GOES-14 with MRMS radar, we expect GOES-16 ABI will be able to identify convective initiation as much as 1-2 hours before it is evident on radar. Our work with GOES-14 SRSOR has also been very valuable by helping us develop the software tools needed for working with GOES-16 data. We have already begun qualitative assessment of ABI data from GOES-16. Figure 2 provides a snapshot from a longer time sequence of GOES-16 ABI showing complex convection and cold pool outflows over South America.

2b--In November, the project gained post-doctoral researcher Max Marchand, whose doctoral research studied lightning/precipitation space/time relationships. He has continued to study these relationships at CIRA using ENTLN lightning observations compared with radar and satellite data, including some early GOES-16 images from Dan Lindsey. ESRL currently plans to assimilate GOES-16 GLM into HRRR by first converting it into an estimate of reflectivity. We will continue to monitor their progress, and as GLM data becomes available, we will meet with them at ESRL to share our results and identify collaborative opportunities.

3a--Our research into techniques for effective cloud initialization included a teleconference early in the project with Thomas Jones at NSSL/CIMMS. Thomas has extensive experience with storm-scale data assimilation of cloud property retrievals from satellites. One of the major challenges he found is saturation of radiances in heavy convection. He developed a cloud water path forward operator that accounts for this and is currently transitioning the techniques into GSI. Once his technique is fully implemented in GSI, we look forward to testing it against the other HRRR data assimilation techniques. Figure 1 shows that currently the primary pathway for cloud information into HRRR is through hydrometeor assimilation that occurs as the last data assimilation step. Cloud top pressure and temperature from GOES are already assimilated by HRRR, but we expect the multi-spectral information from GOES-16 will provide additional skill in distinguishing clouds from snow covered surfaces and in identifying ice clouds versus liquid clouds.

3b--While initializing the convection in the right location, at the right time, and with the right intensity is crucial for accurate forecasts; if the model's environmental state has the wrong profile of stability, moisture, or wind shear large errors can still occur. There are, however, two major challenges to perturbing the model's environmental state. The first is the forward operator to map satellite observations into three-dimensional temperature, moisture, and wind perturbations. The second challenge, impressed upon us by our ESRL collaborators, is that previous efforts to improve capping inversion structure have led to relative humidity biases and can excite spurious convection. Addressing these challenges remains a topic for continued research.

4--Techniques for initializing downbursts depend on the ability for satellite observations to identify the conditions consistent with thermodynamic soundings that support downbursts. Figure 1 shows that the hybrid GSI assimilation is the primary pathway for modifying environmental information (temperature and moisture profiles) that control downburst potential. We have reviewed the fundamental literature by Ken Pryor on this subject, and anticipate collaboration when GOES-16 data products are available. The new multi-spectral data provided by GOES-16 will likely improve the skill in detecting downburst conditions.

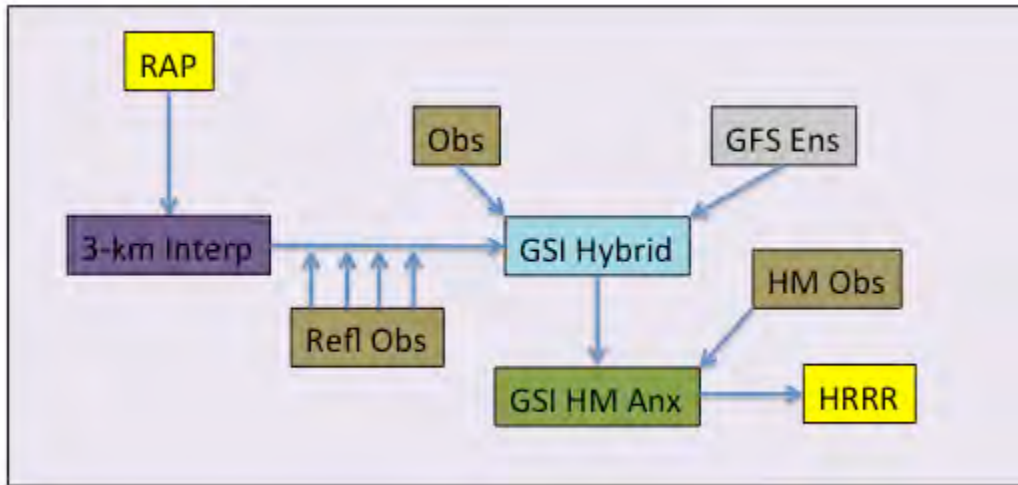

Figure 1. Flowchart illustrating the HRRR data assimilation system.

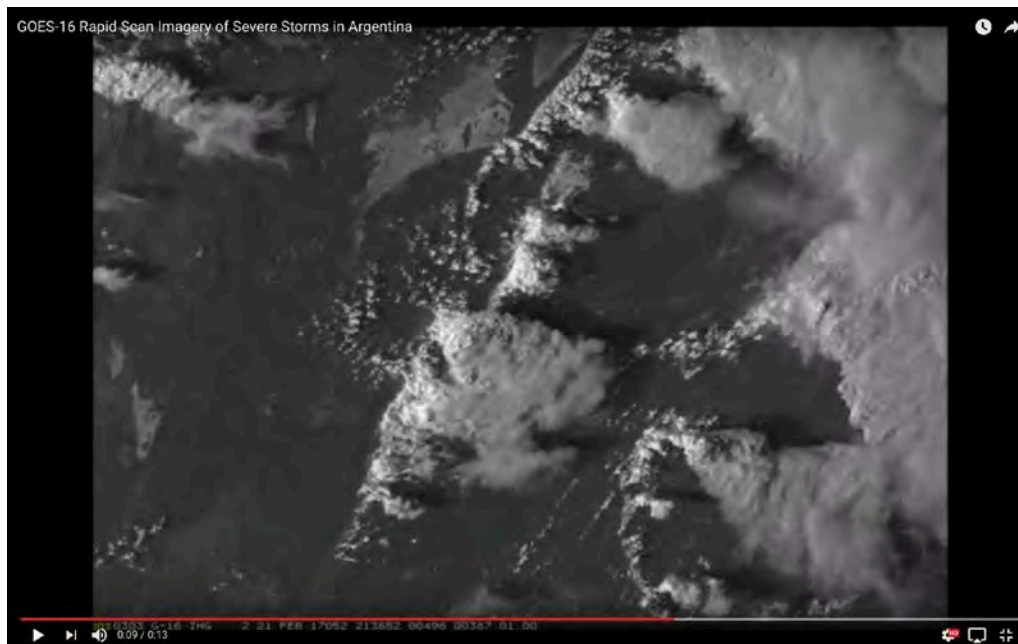

Figure 2. Still frame at 21:36Z from GOES-16 animation on 21 Feb 2017. At this time the storm in the center of the image (which is near Cordoba, Argentina) is producing severe hail. The full animation can be seen at <https://www.youtube.com/watch?v=R8yFZI2idb0>.

Publications: None

Presentations:

Hilburn, K., 2016: GOES-R assimilation: Summary of current capabilities and activities. Presented to Project Team, 20 June 2016.

Hilburn, K., 2016: Summary of telecom with Thomas Jones. Presented to Project Team, 1 July 2016.

Hilburn, K., 2016: Connecting GOES-R with numerical forecast models. Presented to Project Team, 30 August 2016.

Hilburn, K., 2016: Assimilating GOES-R in RAP/HRRR. Presented at NOAA ESRL, 14 September 2016.

Hilburn, K., 2016: Assessment of differences between GOES-13 and GOES-15 imagery. Presented to Project Team, 4 October 2016.

Hilburn, K., 2016: Satellite estimates of latent heating. Presented to AT 652 Remote Sensing of the Atmosphere, 6 December 2016.

Hilburn, K., and M. Marchand, 2017: GOES-R short-term forecast project status. Presented to Project Team, 17 January 2017.

PROJECT TITLE: A GOES-R Proving Ground for National Weather Service Forecaster Readiness and Training

PRINCIPAL INVESTIGATORS: Steve Miller, Ed Szoke, Bernie Connell

RESEARCH TEAM: Steve Miller, Dan Bikos, Renate Brummer, Bernadette Connell, Erin Dagg, Robert DeMaria, Jack Dostalek, Kathy Fryer, Hiro Gosden, Lewis Grasso, Kevin Micke, Andrea Schumacher, Ed Szoke, Dave Watson

NOAA TECHNICAL CONTACT: Satya Kalluri (NOAA/NESDIS) and Steve Goodman (NOAA/NESDIS/GOESR-Program Office)

NOAA RESEARCH TEAM: Donald W. Hillger, John Knaff, Dan Lindsey, Deb Molenaar (NOAA/NESDIS/STAR)

FISCAL YEAR FUNDING: \$603,060

PROJECT OBJECTIVES:

Since its inception in 2008, NOAA's GOES-R Proving Ground (PG) has played a central role in familiarizing forecasters and operational users of GOES-16 data with the new capabilities of the Advanced Baseline Imager (ABI) and the Geostationary Lightning Mapper (GLM). Traditionally, the most relevant forms of information used for PG demonstrations have been imagery from polar-orbiting satellites (e.g., the MODerate-resolution Imaging Spectroradiometer (MODIS) on Terra and Aqua, and the Visible/Infrared Imaging Radiometer Suite (VIIRS) on Suomi National Polar-orbiting Partnership), or else 'synthetic ABI imagery' based on Numerical Weather Prediction (NWP) models run through forward radiative transfer operators. While valuable in terms of illustrating information content and building training materials, the polar products provide limited temporal resolution. Similarly, while synthetic imagery

enables replication of ABI space/time resolution, it is predicated on the NWP information and thus does not represent actual observation data that can be used to confront model forecasts. Despite these limitations, the PG has provided a powerful conduit for coupling NOAA's research and operational communities. In addition to establishing familiarity with GOES-R, PG has established a human interface and rapport that will serve the program for years.

CIRA's involvement in the NOAA GOES-R Proving Ground (PG) over the past year emphasized the demonstration of PG Baseline Products and CIRA-developed Display Aid products. To do so, CIRA worked very closely with the Satellite PG Liaisons and continued to leverage existing capabilities within the organization to develop and demonstrate selected satellite applications (based in part on interactions with users who have articulated their operational needs) and to provide associated training (including SHyMet and VLAB training) and experience directly to NWS forecasters through ongoing support of the Proving Ground project, where proxy and simulated GOES-R products were demonstrated at NWS Weather Forecast Offices (WFOs) and many different National Centers.

As part of a nationally distributed team of Proving Ground algorithm developers and subject matter experts, CIRA continued to work in collaboration with the Cooperative Institute for Meteorological Satellite Studies (CIMSS) at the University of Wisconsin-Madison, the NASA Short-term Prediction Research and Transition (SPoRT) Center located in Huntsville, Alabama, and various operational forecasting partners involved in Proving Ground product usage and evaluation. Emphasis was on 1) very close collaboration with the GOES-R Satellite Liaisons and 2) demonstrating all products within AWIPS II and, where appropriate, N-AWIPS. Demonstration products were adapted to use Himawari-8 data where applicable, paving the way towards transition to the GOES-R ABI.

Most CIRA PG products are made available in real time on the CIRA web page at http://rammb.cira.colostate.edu/ramsdisk/online/goes-r_proving_ground.asp. The web page provides much information on each of the CIRA Proving Ground (PG) products, includes the developer and point of contact as well as a concise but informative "Product Description" that details how the product is made, why it is a PG product, and how it can be used in operations.

This GOES-R Proving Ground project supported the following NOAA mission goals: Weather and Water, Commerce and Transportation and Climate. Enhanced training also prepared the forecaster/manager on how to utilize imagery and products to provide services in these areas.

This annual Proving Ground and Training report covers CIRA work conducted in the following 12 areas:

- Project 1--National Hurricane Center Proving Ground Activities
- Project 2--Pacific Proving Ground Activities
- Project 3--Storm Prediction Center (SPC) Activities
- Project 4--Aviation Weather Center (AWC) Activities
- Project 5--Weather Prediction Center (WPC) and Ocean Prediction Center (OPC) Activities
- Project 6--High Latitude Activities
- Project 7--Imagery Applications and WFO Interactions
- Project 8--AWIPS II and N-AWIPS Development
- Project 9--NHC Satellite Liaison to the National Hurricane Center
- Project 10--Product Documentation and Training for NWS Forecasters
- Project 11--Satellite Hydro-Meteorology (SHyMet) Education and Outreach
- Project 12--NOAA's GOES-R PG commitment to the Coordination Group for Meteorological Satellites:
Enhancing the International Virtual Laboratory (VLaB)

Project 1--National Hurricane Center Proving Ground Activities

In light of the strong core of tropical cyclone expertise and application development, the CIRA/RAMMB Proving Ground Team continued its National Hurricane Center (NHC) Proving Ground activities during

this annual reporting period. CIRA's NHC Proving Ground focused on demonstrating the products listed below during the 2016 Hurricane season:

List of Project Objectives:

- 1--Continue to serve SRSO Imagery for the 2016 NHC PG demonstration
- 2--Continue to make lightning-based TC Rapid Intensification Index (RII) available for the 2016 NHC PG demonstration
- 3--Reduce radii used for inner core and rainband regions for N.E. Pacific TCs in lightning-based RII product radii prior to the start of the 2016 NHC PG demonstration
- 4--Continue to serve GOES-R Natural Color Imagery for the 2016 NHC PG demonstration
- 5--Continue to serve the DEBRA product via the RAMSDIS online website for the 2016 NHC PG demonstration
- 6--Continue work to provide DEBRA in NAWIPS format
- 7--Continue to display the PMI/IR/WV RGB images on our local RAMMB TC-realtime web page and make these images available to the NHC proving ground activities prior to, during, and after the 2016 NHC PG demonstration
- 8--Assist the NHC Satellite Liaison with developing brief NHC-specific training/reference materials for the PMI/IR/WV RGB product, TC structure estimates, and DEBRA prior to the 2016 NHC PG demonstration
- 9--Add TC structure estimates to routine Dvorak fixes and providing this information to NHC for potential evaluation during the 2016 NHC PG demonstration in ATCF format

Project accomplishments by Objectives:

During the NHC Proving Ground Demonstration (August 2016-November 2016) the CIRA/RAMMB Tropical Cyclone Team continued providing the GOES-R proxy products listed above under 1,2,4,5,7 to NHC.

Updated the LB-RII algorithm listed under item 3 was updated and now includes 2 additional years of developmental data (2013 and 2014). Different inner core and outer region radii for the LB-RII were tested for the N.E. Pacific, where TCs tend to be smaller than the Atlantic. We found that reducing these radii degraded product performance. As result, lightning-based predictor radii were kept the same for 2016.

The DEBRA-Dust product was made available to NHC forecasters in N-AWIPS in late summer 2016 (Figure below).

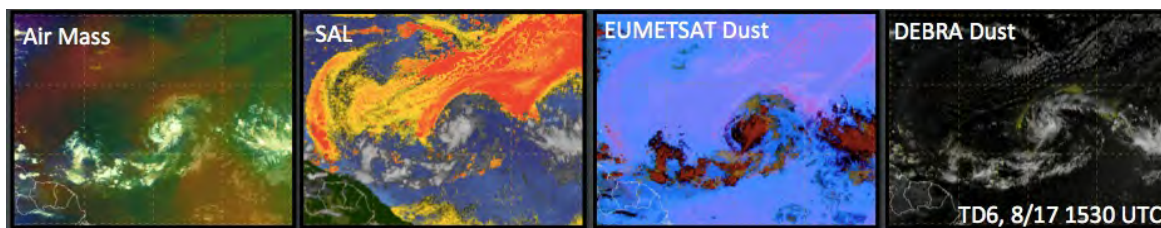

Figure 1. Environmental RGBs continue to be used regularly by HSU and TAFB forecasters. They have been found to be particularly useful for determining influence of surrounding dry Saharan Air Layer (SAL) air on TC development and intensity change.

A PMI/WV/IR product 2-page quick guide was developed for NHC forecasters. Several more NHC-relevant DEBRA-dust examples were collected during the 2016 hurricane season for use in future training (expected no earlier than 2018, as GOES-16 baseline products will be the focus of 2017 efforts).

A method to add wind radii to routine Dvorak fixes has been created and is documented in Knaff et al. (2016). This method has been transitioned to the automated tropical cyclone forecast (ATCF) at JTWC and at NRLMRY and this capability will be available at NHC at the next update of ATCF (May 2017).

Project 2--Pacific Proving Ground Activities

During this past year CIRA deepened its involvement in the Pacific PG by providing additional products specifically used for Tropical Cyclone (TC) forecasting as well as new Himawari product sectors which are centered on Hawaii. Two CIRA employees also participated in person in this year's OCONUS technical interchange meeting.

List of Project Objectives:

- 1--Make lightning-based TC Rapid Intensification Index (RII) available for the Pacific Regions
- 2--Make PMI-IR-WV RGB images, now available on the TC webpage, available to the NHC and Pacific Proving Ground activities on AWIPS II
- 3--Add tropical cyclone structure information to routine Dvorak intensity fixes and provide to CPHC and NHC in ATCF format
- 4--Add web-based Himawari sectors as requests are received from NWS Pacific Region SSD Chief Bill Ward

Project Accomplishments by Objectives:

Developmental data for the N.W. Pacific, Indian Ocean, and Southern Hemisphere was collected and is currently being quality-controlled and processed for use in the LB-RII development code. Once the non-LB RII is updated for these basins (anticipated completion: spring 2017), the lightning-based predictors will be added and tested.

In addition, a method to add wind radii to routine Dvorak fixes has been created which is documented in Knaff et al. (2016). This method has been transitioned to the automated tropical cyclone forecast (ATCF) at JTWC and at NRLMRY and this capability will be available at NHC at the next update of ATCF (May 2017).

As part of our collaboration with NWS Pacific Region, CIRA added multiple web-based Himawari sectors whenever we received requests from their SSD Chief Bill Ward. The figure below depicts the CIRA Himawari GeoColor product (26 September 2016 at 0110 UTC) with the sector made to cover Hawaii.

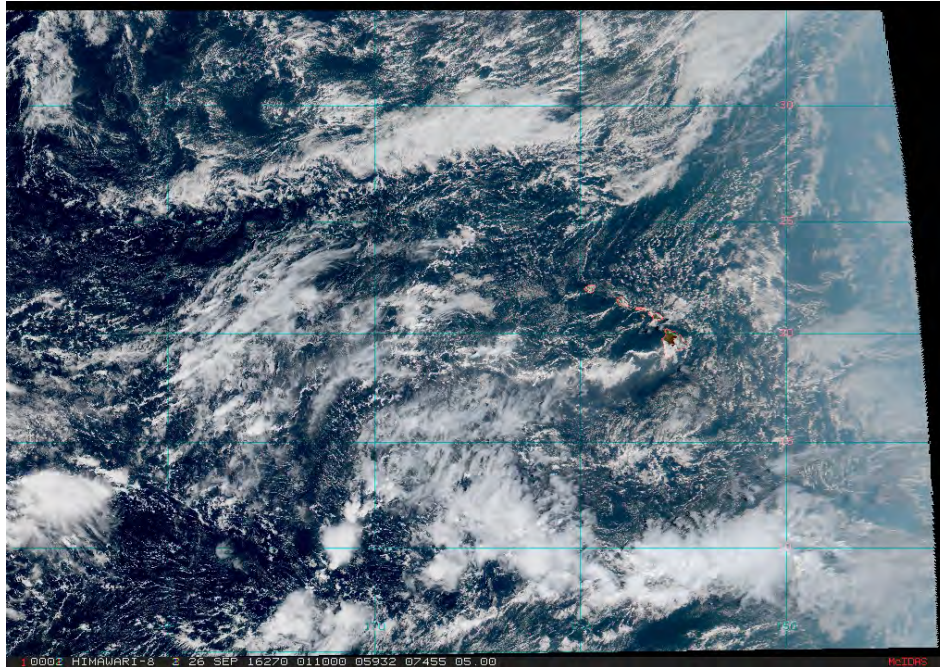

Figure 2. CIRA Himawari GeoColor product (26 September 2016 at 0110 UTC) with the sector made to cover Hawaii.

One of the special Pacific Region products created per request from Bill Ward is a Himawari GeoColor loop over Hawaii remapped as Mercator projection – see email communication below:

From: Dan Lindsey <dan.lindsey@noaa.gov>

Date: Friday, September 2, 2016 at 8:24 AM

To: Bill Federal <bill.ward@noaa.gov>

Subject: Re: FW: AHI geocolor on Hawaii

Hey Bill,

No bother at all. We have the remapped Geocolor loop over Hawaii up and running on the webpage.

Here's a long loop that includes part of yesterday:

http://rammb.cira.colostate.edu/ramsd/online/loop_timestamp.asp?data_folder=himawari-8%2Fhawaii_geocolor&width=1020&height=720&ending_image=hawaii_geocolor_20160902135000.jpg&starting_image=hawaii_geocolor_20160901185000.jpg

Dan

Near-real-time Himawari CIRA GeoColor imagery frequently made the news when tropical cyclones threatened Pacific islands, like in case of Typhoon Haima: Western Pacific Typhoon Haima made landfall as a category 4 storm on the northern Philippine island of Luzon on October 19th between 12 and 18 UTC. Real-time RAMMB/CIRA imagery depicting the storm was used by multiple media outlets which covered the storm, including the Weather Channel (see <https://weather.com/storms/typhoon/news/super-typhoon-haima-lawin-satellite-images>)

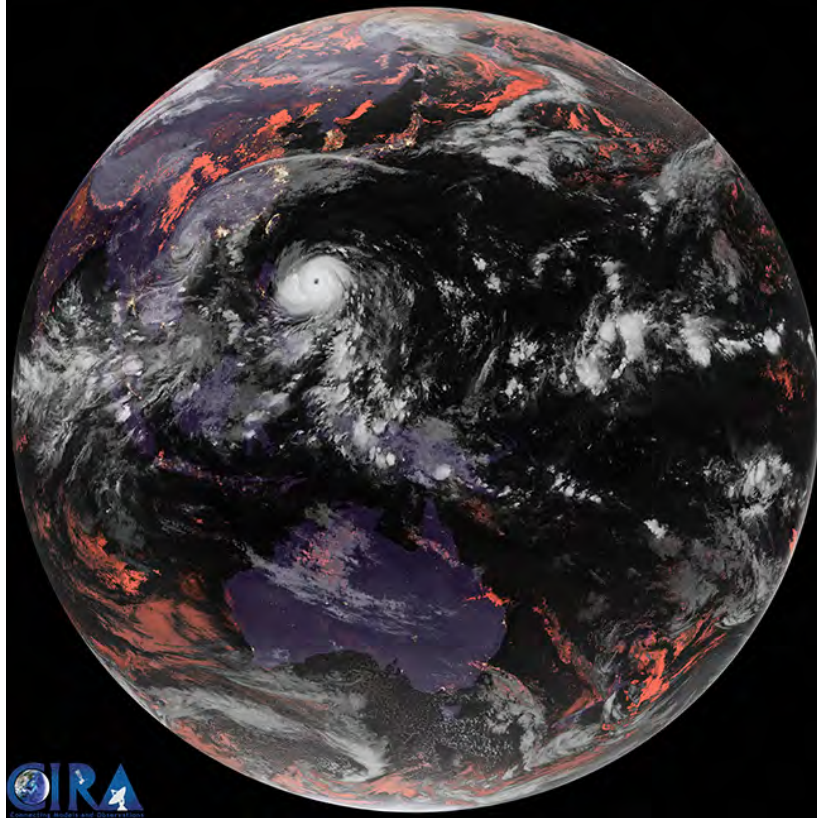

Figure 3. CIRA/RAMMB full disk AHI GeoColor image from Himawari-8 AHI depicting Typhoon Haima on 18 Oct 2016 at 1700 UTC. This is one of several CIRA images used by the Weather Channel at that time.

All real-time imagery produced by the RAMMB/CIRA team is posted on the RAMMB TC real-time webpage at: http://rammb.cira.colostate.edu/products/tc_realtime/

Project 3-- Storm Prediction Center (SPC) Activities

CIRA continued to provide real-time GOES-14 Super Rapid Scan Operations for GOES-R (SRSOR) data when available (1-minute imagery); this support has been well received at the SPC. A paper discussing the use of the data by the SPC was published in *Weather and Forecasting* in March 2016 (lead author B. Line).

Project Objective:

Provide a real-time feed of GOES-14 SRSOR data in NAWIPS format to the Storm Prediction Center, when/if any SRSOR experiments are conducted

Project Accomplishments by Objectives:

During the SRSOR experiment in August 2016, CIRA provided the GOES-14 Super Rapid Scan Operations (1-minute imagery) data for that experiment. In addition in March 2017, CIRA built a special GOES-16 Mesoscale sector selection tool at the SPC's request. On 21st of March 2017, CIRA started the GOES-16 Mesoscale data feed for that sector for use in

operations at SPC. All activities with the SPC are/were always in close coordination with their Satellite Liaison Bill Line (Note: Bill Line recently left that position and he has not been replaced yet).

Project 4--Aviation Weather Center (AWC) Activities

CIRA continued its close relationship with the AWC over the last several years. Satellite Liaison Amanda Terborg has been very proactive in demonstrating PG products. This is accomplished to a broad audience during AWC Testbed experimental periods. Different CIRA PG products have been demonstrated and Amanda administers the needed training as well as providing evaluation of the products. A nice aspect of the AWC is that their global forecast responsibilities enables a wide range of products to be demonstrated, including those that can use Himawari-8 data to closely approximate GOES-R bands and products.

Project Objectives:

- 1--Continue to support AWC Testbed activities by delivering (in real time) synthetic imagery and products
- 2--Work closely with AWC Satellite Liaison Amanda Terborg to deliver the new Geocolor product from Himawari in NAWIPS format.
- 3--Provide successful development of DEBRA dust product from Himawari, begin providing to AWC in real time for evaluation
- 4--Participate in the AWC Summer Testbed Experiment

Project Accomplishments by Objectives:

In order to support the AWC activities and the various aviation-related hazard forecasts, including aircraft icing, convection and visibility hazards such as fog and stratus, CIRA continued to provide the AWC with synthetic satellite imagery in N-AWIPS format, including synthetic bands from the GOES-R Advanced Baseline Imager (ABI). This synthetic imagery was generated from the forecasts of two high resolution (4-km grid spacing) models, the NSSL WRF-ARW and the NAM Nest. Amanda has shared forecaster feedback that has been overwhelmingly positive. The WV imagery has been used to help find regions of potential turbulence, and the 10.35-3.9 μm product is used both for visibility forecasts and to highlight regions of likely aircraft icing.

CIRA continues to make Himawari Geocolor available to the AWC via LDM in NAWIPS format (96 colors) and Amanda has made it available on the AWC forecast floor. The Geocolor product provides a seamless transition from day- to nighttime, and demonstrates capabilities that will be available in the GOES-R era through the use of background-enabled true color imagery in the daytime. Synergy with Suomi National Polar-orbiting Partnership provides the inclusion of a nighttime city lights layer of information at night, useful for rapid orientation of weather phenomena to population centers. In addition, the imagery at night provides enhancement of low clouds and fog, which represent principal concerns at the AWC, through the use of the 10.7-3.9 μm difference product (the current AWIPS "fog product").

At the time this annual report is being written the AHI DEBRA Dust Product is not ready for delivery to AWC yet.

Project 5--Weather Prediction Center (WPC) and Ocean Prediction Center (OPC) Activities

CIRA continued to interact with the WPC and OPC through close coordination with Satellite Liaison Michael Folmer. AS in previous years, Michael Folmer provides frequent product feedback to CIRA and often uses CIRA PG products in his regular blogs.

Project Objectives:

- 1--Continue to provide synthetic imagery and products

2--Continue to provide Geocolor imagery, and in addition for the Pacific area deliver the new Geocolor product from Himawari in NAWIPS format, using Hybrid Atmospherically Corrected (HAC) true color during the day, and the GOES-style-Geocolor nighttime product

Project Accomplishments by Objectives:

Customized domains to support OPC monitoring were established for GeoColor and currently run pseudo-operationally at CIRA, providing imagery in the desired NAWIPS format and color mapping. Some of the products being evaluated at other National Centers have been found to be applicable at the WPC and OPC because of the large area of responsibility for the two centers that includes the much of the Atlantic and Pacific.

An example of some nice usage of GeoColor in this OPC-produced story map was sent out by Michael Folmer to the PG all-hands list on 01 June 2016:

From: Proving Ground All Hands List <pg.allhands@ssec.wisc.edu> on behalf of Michael Folmer <michael.folmer@noaa.gov>

Date: Wednesday, June 1, 2016 at 5:43 AM

To: PG All Hands <pg.allhands@ssec.wisc.edu>

Subject: [pg] OPC Story Map on North Pacific Hurricane Force Lows

All, Jim Kells (OPC) put together the following message introducing OPC's first Story Map on ArcGIS Online. I am honored to be a part of this initiative as a few of the GOES-R proxy products (**GeoColor**, Air Mass RGB) and Himawari imagery are showcased in this project. Please feel free to share with others. The Ocean Prediction Center's first Story Map, "North Pacific Extratropical Hurricane Force Low Centers," has been published on ArcGIS Online and is now publicly available at:

<http://noaa.maps.arcgis.com/apps/MapSeries/index.html?appid=e4ec87a133a14a3380481e6d10f997de>

It presents general information on extratropical hurricane force low pressure systems through interactive maps and stunning satellite imagery, and also unveils statistical information from the historic 2015/2016 North Pacific cold season.

Project 6--High Latitude Activities

The new generation of geostationary satellite imagers, AHI and the ABI, have the ability to reliably view as far poleward as $\pm 65^\circ$ latitude, with sub-optimal coverage at higher latitudes. Currently, AHI provides coverage of the Aleutian Island chain, the Bering Sea and the Kamchatka Peninsula of Russia, which are of importance to the NWS Alaska Region, including the Anchorage and Fairbanks WFOs. This allows now for the Satellite Proving Ground to convert some of the S-NPP PG products developed for the Arctic areas to be converted to AHI and ABI products. CIRA has already developed quite a few AHI imagery products for this purpose.

Project Objectives:

1--Leverage the results of CIRA's FY15 funding of a GOES-R Risk Reduction proposal to work with AHI data in the context of true color, enhanced dust, and cloud/snow discrimination and will continue to demonstrate ABI-like capabilities over parts of Alaska, in coordination with ESSD Chief and Acting Director Carven Scott.

2--Working with GINA, we will supplement selected ABI and AHI products using VIIRS data with applicable channels for areas of the Alaska Region outside the geostationary field of view.

Project Accomplishments by Objectives:

CIRA continued to leverage its connections with the University of Alaska-Fairbanks, the Geographic Information Network of Alaska (GINA) and, in particular, the Alaska Region Proving Ground Satellite Liaison, Eric Stevens, in demonstrating Proving Ground products of value to Alaska Region users. Tom

Heinrichs (GINA) will also serve as POC. We have received excellent feedback from Eric Stevens regarding how our Proving Ground products are being used by forecasters in Alaska, and we have successfully transitioned several (JPSS) products from research to operations with the aid of Eric Stevens and GINA. For areas of the Alaska Region outside the geostationary field of view we will supplement selected ABI and AHI products using VIIRS data with applicable channels.

We currently produce numerous AHI and VIIRS imagery products that cover some (if not all) of the Alaska Region, made available on our RAMSDIS Online website. These include VIIRS True Color RGB, Natural Color RGB, Fire Temperature RGB, Snow/Cloud Discriminator, short- and longwave IR, and a variety of Day/Night Band imagery products that help with volcanic ash, smoke and dust detection for several sectors that include Interior Alaska, the Chukchi Sea, the Aleutian Islands and the Kamchatka Peninsula in Russia. We also produce AHI Natural Color RGB, and several volcanic ash detection products for a North Pacific sector that includes the Aleutian Islands and Kamchatka Peninsula. Furthermore, the default location of the AHI rapid scan (2.5 min imagery) sector covers the Kamchatka Peninsula, unless a major typhoon is present in the tropics. Forecasters have requested this imagery as the Kamchatka Peninsula is a major source region of volcanic ash, as well as hurricane force (HF) lows that ultimately impact the Aleutians and mainland Alaska. We produce rapid-scan versions of Geocolor, Natural Color RGB, and Airmass RGB, in addition to the high-resolution visible channel (AHI Band 3). Full disk versions of the Geocolor, Natural Color RGB, Airmass RGB, and Band 3 are also available, which cover the Aleutian Islands.

We are coordinating with Eric Stevens and Carl Dierking (GINA) to make the VIIRS Fire Temperature RGB and Snow/Cloud Discriminator available to forecasters through AWIPS. An example of the Snow/Cloud Discriminator is shown in the Figure below.

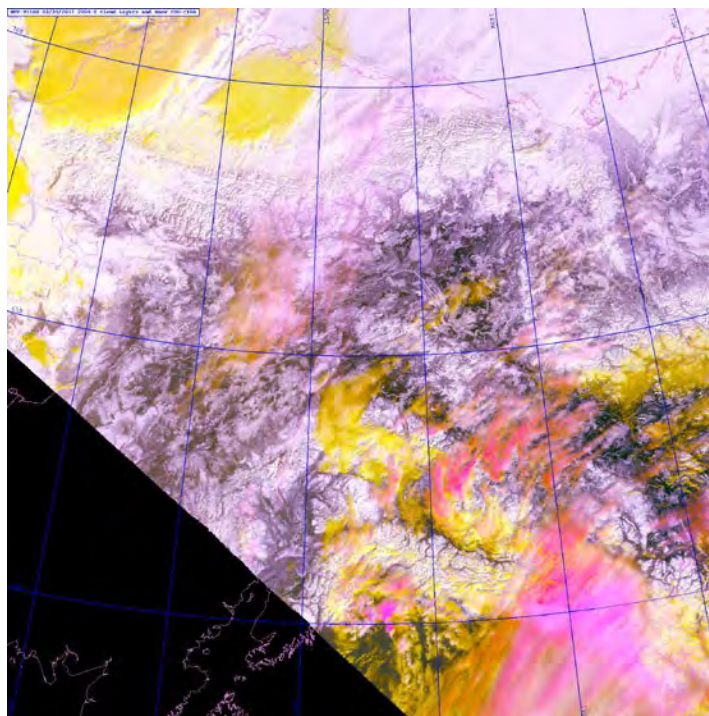

Figure 4. Example VIIRS Snow/Cloud Discriminator over Alaska (20:04 20 March 2017). This product highlights snow in white, low clouds in yellow, mid-level clouds in orange and high clouds in magenta. CIRA's Arctic Blogs receive regularly high praise from the GINA team and are posted directly on the GINA homepage.

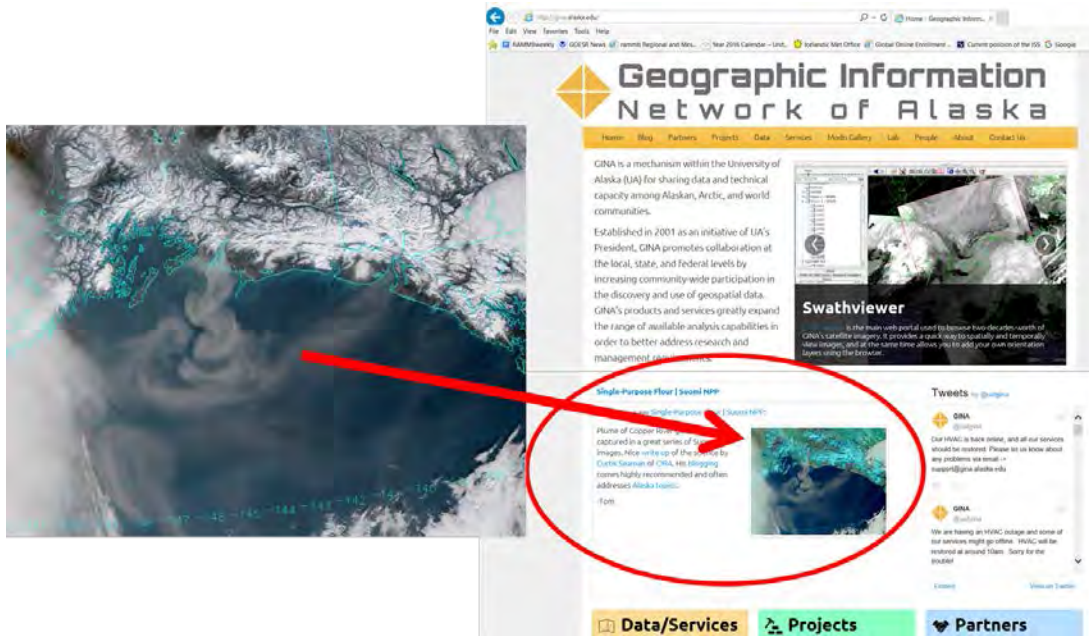

Figure 5. On the left is a CIRA VIIRS True Color RGB image of a glacial flour dust event over the Gulf of Alaska (22:26 UTC 25 October 2016). This glacial flour dust event was described in detail in one of CIRA's Alaska blogs (<http://rammb.cira.colostate.edu/projects/npp/blog/>) . To the right is a screen shot of the University of Alaska-Fairbanks GINA's homepage from late October 2017 linking directly to CIRA's blog.

CIRA's Curtis Seaman received a special invitation from Eric Stevens to attend the upcoming Alaska Fire Science Consortium remote sensing workshop (in April 2017) and to give an invited talk at that conference. Curtis Seaman will combine this trip with a visit to GINA to continue our strong collaboration with this team.

Project 7--Imagery Applications and WFO Interactions

CIRA continued to actively engage NWS forecasters at the WFO level. There are currently 43 WFOs that receive one or more GOES-R PG products from CIRA. New WFOs continued to become interested in and learn about CIRA PG products through various means, including: 1) from other WFOs; 2) through training exercises such as those organized by WFO Liaison Chad Gravelle; 3) by participating in VISIT training to learn more about potential products; 4) interaction through particular events that we may highlight on our PG blog; and 5) presentations at conferences, particular the National Weather Association Annual Meeting, which is well attended by forecasters. Feedback in general always comes via email, AFDs (Area Forecast Discussions), special surveys, blogs, training, shift logs, and verbal feedback.

Project Objectives:

We continued to distribute and improve (if requested) a suite of WFO PG Decision Aid products.

- 1--Continue close collaborations with local partner WFOs Boulder and Cheyenne
- 2--Continue general support of participating WFOs that receive CIRA PG products
- 3--Continue to collect and evaluate forecaster product feedback
- 4--Continue to refine and improve PG products as a result of forecaster feedback

5--Work closely with Satellite Liaison Chad Gravelle to help establish product usage opportunities, collect formal feedback for products where appropriate, and to introduce and evaluate new products as they become available

Project Accomplishments:

During this reporting period we continued to distribute and improve (as requested) a suite of WFO PG Decision Aid products. A new initiative that was started during this past year involved the use of synthetic imagery to demonstrate the new water vapor bands that will be on GOES-R. The full list of CIRA PG products which were successfully demonstrated in AWIPS II is as follows:

- GeoColor (with and without city lights, per forecaster preference; transitioning to ABI)
- Synthetic Imagery (NSSL WRF-ARW and the CONUS NAM and Alaska Nests)
- Snow/cloud discrimination (MODIS)
- Thin cirrus detection (MODIS)
- Blowing dust products (MODIS/VIIRS based)
- Total lightning using the Colorado LMA (in coordination with Steve Rutledge of CSU Atmospheric Science, and Geoffrey Stano of NASA/SPoRT)
- Real-time Super Rapid Scan Operations for GOES-R (SRSOR) imagery when available

During this reporting period CIRA's PG Team continued to coordinate our PG WFO activities with WFO Satellite Liaison Chad Gravelle. We participated in bi-monthly telecons with the Satellite Liaisons, and participated in Satellite Liaison meetings as scheduled. Given our proximity to the Boulder (BOU) WFO we maintained a particularly close working relationship with that office, buoyed by many years of interaction by CIRA Proving Ground WFO Liaison Ed Szoke. Ed continues to work occasional WFO shifts at the WFO Boulder (since the mid-1980s) and holds an important practical knowledge of the issues involved (timing, workload, forecast problems, etc.). The shifts at the WFO BOU provide Ed with the opportunity to use the experimental PG products, as well as to fully interact with the forecast staff. Ed also attended the seasonal WFO workshops (one in the Fall and one in the Spring) and frequently made presentations, or coordinated presentations by others at CIRA and other Proving Ground team partners. CIRA also holds a long-standing relationship with the Cheyenne (CYS), Wyoming WFO. CYS continued to show strong interest in participating in PG activities through enthusiastic staff, including their SOO (Rob Cox) and Satellite Focal Point (Becca Mazur). Dan Bikos and Ed Szoke visited Cheyenne in April 2015 to discuss a project involving total lightning.

Project 8--AWIPS II and N-AWIPS Development

CIRA continued to research and implement new AWIPS II and NAWIPS Proving Ground products. New AWIPS II software builds were deployed as available. AWIPS II and NAWIPS real-time product dissemination, client support and client training also continued into this current project year. The ability to convert existing McIDAS format products to netCDF4 and to generate new netCDF4 format products was critical component of this effort. CIRA staff worked with VLAB, OSG and other Proving Ground partners to develop these capabilities. CIRA also hosted a working session for satellite liaisons and NHC staff to develop a cohesive framework for transitioning all experimental NAWIPS products to the AWIPS2 NCP.

Project Objectives:

- 1--Continue development, dissemination and support of CIRA AWIPS II & NAWIPS PG products.
- 2--Continue hardware procurement and implementation to improve/expand in-house AWIPS II capabilities.
- 3--Continue to participate in NWS AWIPS II training and utilize information to maintain CIRA AWIPS II environment compatibility with NWS partner offices.
- 4--Continue work to improve existing and develop new Himawari and GOES-R AWIPS II RGB products.
- 5--Continue work to develop/evaluate GOES-R era AWIPS II case study ingest, archive and sharing techniques.

- 6--Continue exchange of IT expertise with SPoRT, VLAB and other experimental product development community members.
- 7--Continue participation in the AWIPS II working groups and attend AWIPS II EPDT workshops. Will also investigate feasibility of CIRA-hosted EPDT.
- 8--Continue collaborative work with the NWS WFOs, National Centers and Satellite Liaisons.

Project Accomplishments by Objectives:

Efforts continued to improve existing and develop new Himawari and GOES-R AWIPS II RGB products and training. Some CIRA GOES-R era RGB products, such as Rayleigh corrected true color) are too computationally intensive to run on AWIPS II workstations. IT staff worked with NCO partners and Satellite Liaisons to develop pseudo 8 bit RGB products that can be displayed in NCP because the AWIPS II NCP does not have the software components necessary to display 24 bit RGBs. Work on AWIPS II 10 and 11 bit color table development with the GOES-R Color Table Working Group continued.

Support for development of AWIPS II training case studies continued in this past year as well. The team worked with WDTB staff to successfully implement a beta version of the WES2 software. Full case study archive and processing capabilities similar to NWSFO's are now available. The software has been used to process several case studies for training courses.

CIRA IT staff also continued participation in the AWIPS II developer working group implemented to facilitate Cooperative Institute/Proving Ground participation in AWIPS II product development. Deb Molenaar and Scott Longmore continued their collaboration with SPoRT and continued to share AWIPS II expertise. They both attended SPoRT hosted EPDT work sessions. CIRA also hosted two EPDT work sessions at the CIRA location in Fort Collins, Colorado. CIRA IT staff also continued to review AWIPS II training materials as they become available on the Commerce Learning Center, and utilized relevant information to advance AWIPS II capabilities for research and training staff and field partners.

After the successful GOES-R launch in November 2016, access to the NESDIS PDA GRB feed was established. CIRA's GOES-R satellite groundsystem is just about ready to ingest and store GOES-16 data. CIRA leveraged other funds (mostly GOES-R Program Office Groundsystem funds and NESDIS/STAR Groundsystem funds) to complete its GOES-R satellite groundsystem. No GOES-R PG project funds were utilized for this purpose. The GOES-R PG project will benefit from CIRA's ability to ingest GOES-R GRB data starting in April 2017. Real-time and archived PDA GRB data is being provided to SPC and CRH while TOWR-S software fixes are implemented.

Project 9--NHC Satellite Liaison to the National Hurricane Center

CIRA continued to support Andrea Schumacher as the Satellite Liaison (SL) to the National Hurricane Center. This is a half-time FTE position. The main task of the CIRA NHC SL is to work in close coordination with the NHC Satellite Focal Points (M. DeMaria, M. Brennan, and J. Beven) and SOO (C. Landsea) on the NHC Proving Ground demonstrations.

Project Objectives:

- 1--Participate in PG-related meetings, workshops, conference calls, and training as required (Note: Required travel should not exceed 5 trips per year, with at least 2 of those trips being visits to NHC)
- 2--Coordinate with developers, training staff, NHC Satellite Focal Points, and other Satellite Liaisons to develop and deliver training on GOES-R/JPSS demonstration products, as needed
- 3--Assist with development of annual NHC Proving Ground Demonstration Plan
- 4--Collect feedback from NHC and TAFB forecasters during the NHC Proving Ground Demonstration period (August - November)
- 5--Organize annual Proving Ground review (either remote or in-person)
- 6--Prepare annual NHC PG report

Project Accomplishments by Objectives:

CIRA's NHC SL participated in numerous Proving Ground-related meetings, workshops, and conference calls. Travel included 2 trips to NHC (Sep 2016 and Feb 2017, Miami FL), the GOES-R PG/User Readiness Conference (May 2016, Kansas City KC), and the OCONUS Technical Interchange (June 2016, Honolulu HI).

The NHC SL ran a supplemental ABI/AHI training workshop with co-Liaison M. Folmer at NHC on 16 Feb 2017.

The 2017 NHC Demonstration Plan was completed at the end of Jan 2017 and was approved for implementation on 21 Feb 2017.

The NHC SL gathered remote feedback on NHC PG demonstration products via emails and phone calls during the 2016 hurricane season. She also gathered in-person feedback and provided PG-related product support during her visit to NHC from 28 Aug - 2 Sep 2016 (during active operations for TS Hermine, see Figure below). During the 2017 NHC Proving Ground Annual Review held at the NHC on 17 Feb 2017, further feedback was collected from forecasters, program managers, and developers (approximately 10 participants in person, 20 remote). The 2016 NHC Proving Ground final report is currently being prepared and will be submitted in March 2017.



Figure 6. CIRA Geocolor RGB Product used by NHC Director Richard Knabb during an interview with The Weather Channel about TS Hermine.

Project 10--Product Documentation and Training for NWS Forecasters

In support of the GOES-R Product Demonstration and Training for NWS Forecasters, CIRA continued to work very closely with the Office of the Chief Learning Officer (OCLO), the satellite training advisory team (STAT) and training developers at CIMSS, COMET, and CIMMS to develop the Satellite Foundational Course for GOES-R (SatFC-G). The SatFC-G provides training for NWS operational forecasters to use new satellite data and products.

Project Objectives:

- 1--Develop new proving ground product demonstration material
- 2--Merge existing modules with new products
- 3--Continue new PG CIRA Blog updates
- 4--Track usage of products
- 5--Track forecaster feedback
- 6--Work closely with PG Liaisons, COMET, SPoRT and CIMSS on training activities and the more formal/required NWS training

Project Accomplishments by Objectives:

Where appropriate, PG demonstration content and modules were merged with current VISIT and SHyMet activities to show how new capabilities complement and/or improve upon current product capabilities. CIRA also continued to interact with VISIT and SHyMet counterparts at CIMSS and kept abreast of activities being done through SPoRT, COMET, and EUMETSAT to maximize the ongoing efforts in this area.

Project 11--Satellite Hydro-Meteorology (SHyMet) Education and Outreach

The overall objective of the SHyMet program is to develop and deliver comprehensive distance-learning courses on satellite hydrology and meteorology. This project leverages the structure of the VISIT training program but is distinct in that VISIT focuses on individual training modules, while SHyMet organizes modules into courses. This work was done in close collaboration with experts at CIRA, the Cooperative Institute for Meteorological Satellite Studies (CIMSS), the Short-term Prediction Research and Transition Center (SPoRT), the Cooperative Institute for Mesoscale Meteorological Studies (CIMMS), COMET, and the National Weather Service (NWS) Office of the Chief Learning Officer (OCLO) which includes the Training Center (NWSTC), the Warning Decision Training Division (WDTD), and the Forecast Decision Training Division (FDTD). The challenge is to provide necessary background information to cover the many aspects of current image and product use and interpretation as well as evaluate data and products available from new GOES-R/16 satellite technologies and provide new training on these tools to be used operationally. In order to have training materials available for users when GOES-R was launched on 19 November 2016, the SHyMet team collaborated with the NOAA Satellite Training Advisory Team (STAT) and partners mentioned above on developing and posting content for the Satellite Foundation Course for GOES-R/16 (SatFC-G)

Project Objectives:

- 1--Interact with CIMSS, NWS OCLO (FDTD, WDTD, and NWSTC), satellite liaisons, GOES-R and JPSS Satellite Proving Ground Partners, COMET, SPoRT, CIMMS, and groups external to the US including the WMO VLab to meet high priority GOES-R training for user readiness. This includes participating in conference calls: STAT team (weekly), VISIT/SHyMet (monthly), COMET (monthly), GOES-R/JPSS Proving Ground (quarterly)
- 2--Create the SHyMet Satellite Foundation Course for GOES-R/16 web pages for users external to NOAA; provide partial support for the creation of content for the SatFC-G course; maintain and track metrics for the SatFC-G and the existing four SHyMet courses: Intern, Forecaster, Tropical, and Severe Thunderstorm.
- 3--Contribute GOES and GOES-R content to blogs, to the VISIT Satellite Chat (interactive Webinar sessions), and monitor and respond to questions and comments proposed through the NWS VLab "satellite help desk" forum. The materials that are presented align with NWS Satellite Training plan to highlight use of new GOES-R/16 satellite imagery in recent significant weather events. These activities were done in collaboration with the VISIT team.
- 4--Attend meteorological and educational conferences and symposiums as the opportunities arise to present materials related to SHyMet/GOES-R and to actively solicit user needs from the community.

Project Accomplishments by Objectives:

1-- Interact with CIMSS, NWS OCLO (FDTD, WDTD, and NWSTC), satellite liaisons, GOES-R and JPSS Satellite Proving Ground Partners, COMET, SPOrT, CIMMS, and groups external to the US including the WMO VLab to meet high priority GOES-R training for user readiness. This includes participating in conference calls: STAT team (weekly), VISIT/SHyMet (monthly), COMET (monthly), GOES-R/JPSS Proving Ground (quarterly)

-During the past year, high emphasis was put on developing content for the Satellite Foundation Course for GOES-R (SatFC-G). The organizational aspect of this required weekly participation in STAT calls to report on: 1) progress of obtaining and displaying Advanced Himawari Imagery (AHI) that were used for case examples, 2) module creation, 3) subject matter expert review, 4) NWS Science and Operations Officer (SOO) review, 5) module revision, 6) quiz creation, and 7) publishing the final version to the web page.

The calls also served as a means to address related issues that arose during the process. Both the SHyMet and VISIT programs were leveraged for this activity. The following objective provides more information on the content created for SatFC-G.



2--Create the SHyMet Satellite Foundation Course for GOES-R/16 web pages for users external to NOAA; provide partial support for the creation of content for the SatFC-G course; maintain and track metrics for the SatFC-G and the existing four SHyMet courses: Intern, Forecaster, Tropical, and Severe Thunderstorm.

- Content developed at CIRA in collaboration with the VISIT project includes:

- SatFC-G: "GOES-R ABI Water Vapor Bands". (at right Figure 1)
- SatFC-G: "GOES-R Baseline product: Hurricane Intensity Estimate"
- SatFC-G: "GOES-R Baseline product: Rainfall rate".
- SatFC-G: "GOES-R Introduction to Mesoscale and Synoptic Sections".
- SatFC-G: "GOES-R Pre-convective Environment".
- SatFC-G: "GOES-R Pre-convective Cloud Features".
- SatFC-G: "GOES-R Boundary-forced convection".
- SatFC-G: "GOES-R Mountain waves and orographic enhancement".
- SatFC-G: "GOES-R Marine and Polar Mesolows".
- SatFC-G: "GOES-R Cumulus Growth". (at right Figure 2.)
- SatFC-G: "GOES-R Discrete Storms".
- SatFC-G: "GOES-R Mesoscale Convective Systems".
- SatFC-G: "GOES-R Cyclogenesis Life Cycle".
- SatFC-G: "GOES-R Low-level jet features".
- SatFC-G: "GOES-R General Circulation Patterns".
- SatFC-G: "GOES-R Atmospheric Rivers".
- SatFC-G: "Comparing NWP Synthetic Satellite Imagery to Observed Satellite Imagery".

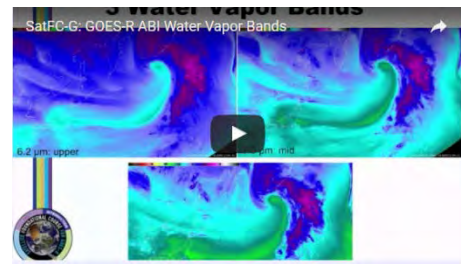

Figure 7. Water Vapor Band module



Figure 8. Cumulus Growth module.

The complete module listing that includes content from all developers is shown in Table 1. The NWS OCLO/FDTD took the lead in organizing the content on NOAA's Commerce Learning Center Learning Management System (CLC LMS) and are responsible for tracking metrics for the NWS. Because users external to NOAA cannot access NOAA's CLC LMS, a SHyMet course page was established for SatFC-G. http://rammb.cira.colostate.edu/training/shymet/satfc-g_intro.asp

Table 1. Satellite Foundation Course for GOES-R/16 (SatFC-G) – Complete module listing

Topic	Title	Length	Contributor
Introduction	Basic Principles of Radiation	15	COMET
Introduction	Basic Operations of ABI on GOES-R	15	CIMSS
Introduction	GOES-R ABI Visible and Near-IR Bands	15	COMET
Introduction	GOES-R ABI Near-IR Bands	15	COMET
Introduction	GOES-R ABI IR Bands, Excluding Water Vapor	30	COMET
Introduction	GOES-R ABI Water Vapor Bands	25	CIRA
Introduction	GOES-R Multi-channel interpretation approaches	30	CIMSS
Introduction	GOES-R Aerosols in AWIPS	10	CIMSS & SMCD
Introduction	GOES-R Cloud and microphysical products, fog and low stratus	15	CIMSS
Introduction	GOES-R Fire characterization, land surface temperature and snow	10	CIMSS
Introduction	GOES-R Baseline Product: Hurricane Intensity Estimate	10	CIRA, CIMSS, & STAR
Introduction	GOES-R Baseline Product: Rainfall rate	10	CIRA & STAR
Introduction	GOES-R Baseline Product: Legacy Atmospheric Profiles	10	CIMSS
Introduction	GOES-R Baseline Product: Derived Motion Winds	10	CIMSS
Introduction	GOES-R Baseline Product: Volcanic Ash	10	CIMSS & STAR
GLM	Introduction to the Geostationary Lightning Mapper (GLM)	30	COMET
GLM	Visualizing the GLM in AWIPS	10	SPoRT
Meso/Synop	GOES-R Introduction to Mesoscale and Synoptic Sections	10	CIRA
Convection	GOES-R Pre-convective environment	15	CIRA
Convection	GOES-R Pre-convective cloud features	10	CIRA
Convection	GOES-R Boundary-forced convection	10	CIRA
Mesoscale	GOES-R Mountain waves and orographic enhancement	10	CIRA
Mesoscale	GOES-R Fog / Low clouds: Formation and dissipation	10	CIMSS
Mesoscale	GOES-R Marine and polar mesolows	10	CIRA
Convection	GOES-R Cumulus growth	20	CIRA
Convection	GOES-R Discrete Storms	20	CIRA
Convection	GOES-R Mesoscale Convective Systems	10	CIRA
Synoptic	GOES-R Cyclogenesis Potential Vorticity concepts	10	CIMSS
Synoptic	GOES-R Cyclogenesis life cycle	20	CIRA
Synoptic	GOES-R TROWAL Formation	10	CIMSS
Synoptic	GOES-R Low-level jet features	10	CIRA
Synoptic	GOES-R General Circulation Patterns	10	CIRA
Synoptic	GOES-R Atmospheric Rivers	10	CIRA
Synoptic	GOES-R Tropical to Extratropical Transition	10	COMET
NWP	Impact of Satellite Observations on NWP	15	COMET
NWP	GOES-R Impacts on Satellite Data Assimilation	5	COMET
NWP	Comparing NWP Synthetic / Simulated Satellite Imagery to Observed Satellite Imagery	10	CIRA

The following four SHyMet courses continue to be administered:

-- The SHyMet *Intern* course touches on Geostationary and Polar orbiting satellite basics (areal coverage and image frequency), identification of atmospheric and surface phenomena, and provides examples of the integration of meteorological techniques with satellite observing capabilities.

(http://rammb.cira.colostate.edu/training/shymet/intern_intro.asp).

This continues to be the most popular course.

-- The SHyMet for *Forecaster* course covers satellite imagery interpretation and feature identification, water vapor channels, remote sensing applications for hydrometeorology, aviation hazards, and what to expect on future satellites. http://rammb.cira.colostate.edu/training/shymet/forecaster_intro.asp

--The *Tropical* track http://rammb.cira.colostate.edu/training/shymet/tropical_intro.asp of the SHyMet Course covers satellite imagery interpretation and application of satellite derived products in the tropics as well as the models used at NHC for tropical cyclone forecasting.

-- The *Severe Thunderstorm Forecasting* Course

http://rammb.cira.colostate.edu/training/shymet/severe_intro.asp

covers how to integrate satellite imagery interpretation with other datasets in analyzing severe thunderstorm events.

SHyMet Course	Total since debut		March 2016 - Feb 2017		Course Debut
	Registrations	Completions	Registrations	Completions	
SatFC-G (external to NOAA LMS)	61	3	32 US 24 International 5 unknown	2 US 1 International	December 2016
Intern	517	383	25	11	April 2006
Forecaster	73	46	5	0	January 2010
Tropical	45	22	3	0	August 2010
Severe	65	40	3	0	March 2011

3--Contribute GOES and GOES-R content to blogs, to the VISIT Satellite Chat (interactive Webinar sessions), and monitor and respond to questions and comments proposed through the NWS VLab “satellite help desk” forum. The materials that are presented align with NWS Satellite Training plan to highlight use of new GOES-R/16 satellite imagery in recent significant weather events. These activities were done in tandem with VISIT activities.

During the past year from March through September, considerable effort was directed towards the development of the SatFC-G and less effort was directed towards blogs and the virtual VISIT Satellite chat session.

The VISIT Satellite Chat sessions are designed to discuss recent significant weather events with the objective of demonstrating satellite products that can be applied to operational forecasting. These sessions are brief and often lead to products being made available or further discussed in the VISIT blog. In the past year, the following sessions were organized by VISIT/SHyMet and highlighted both internal and external presenters:

- Sheldon Kusselson (retired NOAA/NESDIS) titled “Satellite Derived Layered Precipitable Water (LPW) and Total Precipitable Water (TPW) products: Applications for the West Coast this 2016-2017 Winter Season”. (17
- Michael Jurewicz (NOAA/NWS WFO Binghamton, NY) titled “The “Super” Lake-Effect Event of 19-21 November 2016 across Western/Central New York. (15 December 2016)
- Scott Lindstrom (CIMSS/SSEC/UW) on the Oregon tornado event of 14 October 2016. (20 October 2016)
- Andrea Schumacher (CIRA/CSU NHC Satellite Liaison) and Michael Folmer (Satellite Liaison for OPC/SAB/TAFB/WPC) on Hurricane Matthew. (5 October 2016)

- Brad Pierce (NOAA/NESDIS/STAR) title “High Resolution Trajectory-Based Smoke Forecasts of the Fort McMurray wildfire using VIIRS Aerosol Optical Depth”. (18 May 2016)
 - Michael Folmer (Satellite Liaison for OPC/SAB/TAFB/WPC) titled “February Hurricane-Force Events: OPC perspective on GOES-14 SRSOR. (27 April 2016)
 - Matt Elliott (NOAA/NWS WFO Sterling, VA) on AWIPS Lightning Outages. (30 March 2016)
- Recorded sessions are located here: http://rammb.cira.colostate.edu/training/visit/satellite_chat/

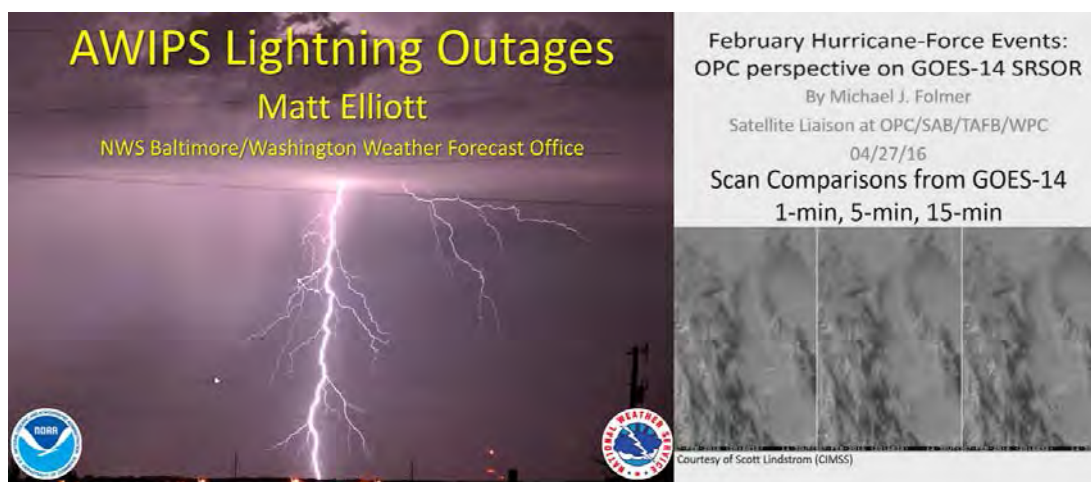

Figure 9. Introductory slides for the March (left) and April (right) 2016 virtual VISIT Satellite Chat sessions.

The VISIT blog is intended to open the doors of communication between the Operational, Academic and Training Meteorology communities. The blog averages around 170 views per month and is located here: <http://rammb.cira.colostate.edu/training/visit/blog/>

A satellite help desk exists in the NOAA Virtual Lab. So far the activity through the help desk has been light. We will continue to monitor it. <http://rammb.cira.colostate.edu/training/visit/helpdesk.asp>

- 4--Attend meteorological and educational conferences and symposiums as the opportunities arise to present materials related to SHyMet/GOES-R and to actively solicit user needs from the community.
- See the presentations listed below.
- Community Outreach at NOAA/Boulder: Ed Szoke gave an hour long weather talk at “8th Grade Science Days” on 6 and 11 October and to a visiting 5th Grade class on 3 November. He also participated in the NOAA Family Tour day on 20 December. Ed Szoke has also been advising (as a Committee Member) a Master’s student in meteorology at the University of Colorado in Boulder, Matt Steiner, with his defense scheduled for March 2017.

Project 12--NOAA's GOES-R PG commitment to the Coordination Group for Meteorological Satellites: Enhancing the International Virtual Laboratory (VLaB)

The World Meteorological Organization (WMO) Virtual Laboratory for Education and Training in Satellite Meteorology (VLaB) is a collaborative effort joining major operational satellite operators across the globe with WMO regional training centers of excellence in satellite meteorology. Those regional training centers serve as the satellite-focused training resource for WMO Members. Through its cooperative institute for Research in the Atmosphere (CIRA) at Colorado State University (CSU), NOAA/NESDIS sponsors Regional Training Centers of Excellence (CoE) in Argentina, Barbados, Brazil, and Costa Rica.

The top-level objectives of the VLab are:

- 1-- To provide high quality and up-to-date training and supporting resources on current and future meteorological and other environmental satellite systems, data, products and applications;
- 2-- To enable the regional training centers to facilitate and foster research and the development of socio-economic applications at the local level through the National Meteorological and Hydrological Services.

Enhanced training and coordination of training that is specifically targeted for GOES-R/16 and accomplished under this project will prepare forecasters, researchers, and managers on how to utilize imagery and products to provide services and training in these areas. Other CIRA RAMMB projects are leveraged to meet the VLab top level objectives.

Specific Objectives:

- 1--Provide partial support (2 months) for the WMO Technical Support Officer (TSO) position.
- 2--Provide GOES-R examples and partial support for monthly weather briefing sessions of the WMO VLab Regional Focus Group (RFG) of the Americas and the Caribbean.
- 3--Participate in virtual and in-person meetings of the WMO VLab Management Group, activities of the NOAA GEONETCast Americas (GNC-A) coordination group, and the WMO Inter-Programme Expert Team on Satellite Utilization and Products (IPET-SUP).
- 4--Leverage NOAA and WMO VLab partners to organize and deliver virtual and in-person GOES-R training on data and product access, display, and interpretation.

Project Accomplishments by Objective:

1--This project provides partial monetary support (2 months) for a WMO VLab Technical Support Officer (TSO), Luciane Veeck. Her efforts provide a very important stabilizing factor for the global coordination of training efforts under the umbrella of the WMO VLab. Member countries have access to her resources through the entire year. Luciane was also supported through CIRA under a WMO grant and another CIRA project during the past year. Highlights of her work that benefit the WMO community and the US include:

- Maintenance of the VLab central website and the VLab calendar of events <http://vlab.wmo.int>
- VLMG-8 meeting support (9-13 May 2016) – Coordination and organization of meeting logistics and agenda, collection of Satellite Operator and Centre of Excellence Status reports, analysis of reports, and participation in the meeting. Follow up activities included writing, reviewing and publishing the meeting summary report and tracking action items. The full report can be downloaded from the VLab website listed above under Publications/VLMG reports.
- WMO Education and Training (WMO-ETR) Online Course for Trainers 2016 – The WMO Online Course for Trainers of Regional Associations III (South America) and IV (North and Central America and the Caribbean) ran 29 March - 26 June 2016. In coordination with WMO ETR staff, other WMO trainers, and B. Connell, the TSO facilitated “Unit 11: Facilitated Learning”, and “Unit 12: Organizing and Delivering Training” during 13-30 June.
- CALMet Moodle Users Course Development – Collaboration occurred with the WMO ETR and with the Community for the Advancement of Learning in Meteorology (CALMet) throughout the past year to give continuation to the design of the Moodle course. Moodle is a free open source Course Management System (CMS). The course (Units 1, 2 and 3) was launched as part of CALMet Online 2016, with an online demo presentation on 27 September 2016.
- Climate Virtual Round Table (VRT) Global Event – Support for the organizing of the Climate VRT involved revision of slides, discussion of opportunities for engagement in online presentations, as well as the need for additional resources in easy to use formats.
- A VLab status report and presentation slides were prepared for the WMO 44th Plenary Session of the Coordinating Group for Meteorological Satellites (CGMS-44), which took place in Biot, France (6-10 June 2016). The full report can be downloaded from the VLab website listed above under Publications/Other



reports. The slides were presented at CGMS-44 by Stephan Bojinski, the WMO Space Programme Representative.

- The revised Satellite Skills and Knowledge for Operational Meteorologists document was submitted to the WMO Commission for Basic Systems (CBS).

https://www.dropbox.com/s/j2fuwqk89ltu3at/SatESkills_V2.pdf?dl=0

- Coordination and collaboration efforts were directed towards developing a survey to determine the best training approaches to Red Green Blue (RGB) image creation and interpretation. EUMETSAT hosted the survey and VLMG members provided input and comments to the survey questions. All VLab members were given the opportunity to respond to the survey during the period 12 December 2016 to 8 January 2017.

2--Provide GOES-R examples and partial support for monthly weather briefing sessions of the WMO VLab Regional Focus Group (RFG) of the Americas and the Caribbean.

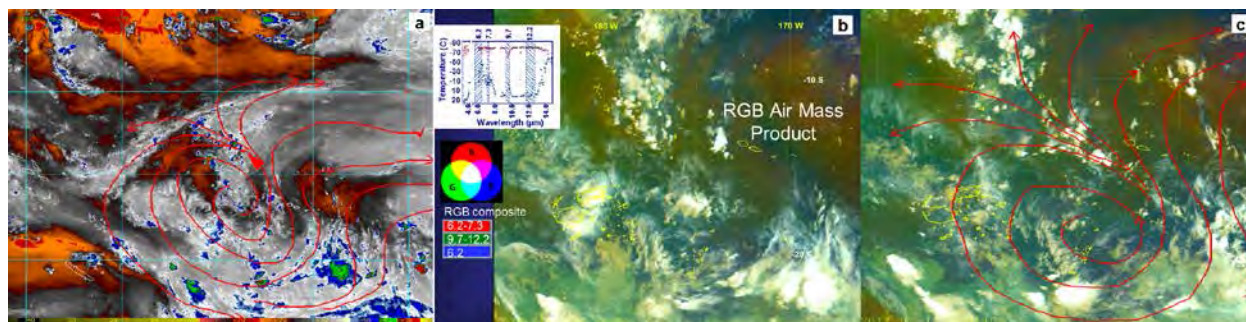

Figure 10. During the January 2017 session, in anticipation of GOES-14 imagery, an example from Himawari AHI imagery was shown to highlight applying what we currently observe: a) Water vapor imagery with the synoptic flow pattern, b) a brief background of the Red/Green/Blue (RGB) components of the RGB Air Mass product, and c) the realization of the synoptic pattern in the RGB Air Mass imagery

--The WMO Virtual Laboratory Regional Focus Group of the Americas and Caribbean conducted 12 monthly bilingual (English/Spanish) weather briefings. The briefings made use of VISITview software to present GOES and POES satellite imagery from CIRA and GoToWebinar for voice communication over the Internet. Over the calendar year 2016, the participants from the U.S. included: CIRA, the NWS International Desk at NCEP/WPC, NWS/Office of the Chief Learning Officer (OCLO) Forecast Decision Training Division (FDTD), the NWS Training Center, the UCAR/JOSS-NWS International Activities Office, and UCAR/COMET. Thirty countries outside the US participated: Argentina, Bahamas, Barbados, Belize, Bolivia, Brazil, Cape Verde, Cayman Islands, China, Colombia, Costa Rica, Dominica, Ecuador, El Salvador, Germany, Guatemala, Haiti, Honduras, Mexico, Netherlands, Panamá, Paraguay, Peru, Russia, Slovakia, Spain, Suriname, Trinidad and Tobago, Uruguay, and United Kingdom. M. Davison and J. Galvez at the NCEP International Desks led the discussions (10 and 2 respectively). Participants offered comments and questions for their regions. The number of countries participating each month ranged between 7 and 18 (average 11); and the number of participants each month ranged between 8 and 48 (average 25). The sessions were recorded and can be accessed here: http://rammb.cira.colostate.edu/training/rmtc/fg_recording.asp

3-- Participate in virtual and in-person meetings of the WMO VLab Management Group, activities of the NOAA GEONETCast Americas (GNC-A) coordination group, and the WMO Inter-Programme Expert Team on Satellite Utilization and Products (IPET-SUP).



Figure 11. Participants attending the WMO VLab Management Group meeting at CIMH in Barbados during 9-13 May.

CIRA participated in the eighth WMO VLab Management Group (VLMG-8) meeting on 9-13 May hosted by the Caribbean Institute for Meteorology and Hydrology (CIMH) in Barbados. Funding for travel to this meeting was provided by the CIMH project “Programmes for Building Regional Climate Capacity in the Caribbean (<http://rcc.cimh.edu.bb/>) and the SHyMet Training Grant.

The main topics from the meeting were:

- VLab efficiency
- Satellite skills and knowledge for operational meteorologists
- Language translation of training resources
- Evaluation of training impact
- User readiness (particularly relevant for GOES-R)
- Climate services
- Weather ready nations, a global training campus, and continuation projects and expansion over the coming year.

The motivation behind VLab activities is to build a strong training foundation to make it is easier to get messages, information, and data to the user. The meeting was well attended by 13 Centres of Excellence: Argentina, Australia, Barbados, Brazil, China (Beijing and Nanjing), Costa Rica, Kenya, Niger, Oman, Republic of Korea, Russian Federation, South Africa, and Morocco. Only one satellite operator was represented directly (EUMETSAT). NOAA was represented through its collaborator at CIRA; INPE and CONAE were represented through their CoE representatives.

CIRA participated in virtual VLMG meetings on 20 September 2016 and 18 January 2017.

CIRA participated in virtual IPET-SUP meetings on 19 May, 13 July, and 15 November 2017.

GEONETCast-Americas (GNC-A) is a great way to provide instructional material to users as well as provide products. It is a low cost alternative to many users in countries that still do not have adequate internet access. It is also a good backup for emergency preparedness. The lower bandwidth capability prohibits sending level 1B type imagery, but potential products for users are those that are considered to meet the 9 GEO societal benefit areas. GNC-A usage is strongly linked to training and aspects of this are covered in the next objective.

4--Leverage NOAA and WMO VLab partners to organize and deliver virtual and in-person GOES-R training on data and product access, display, and interpretation.

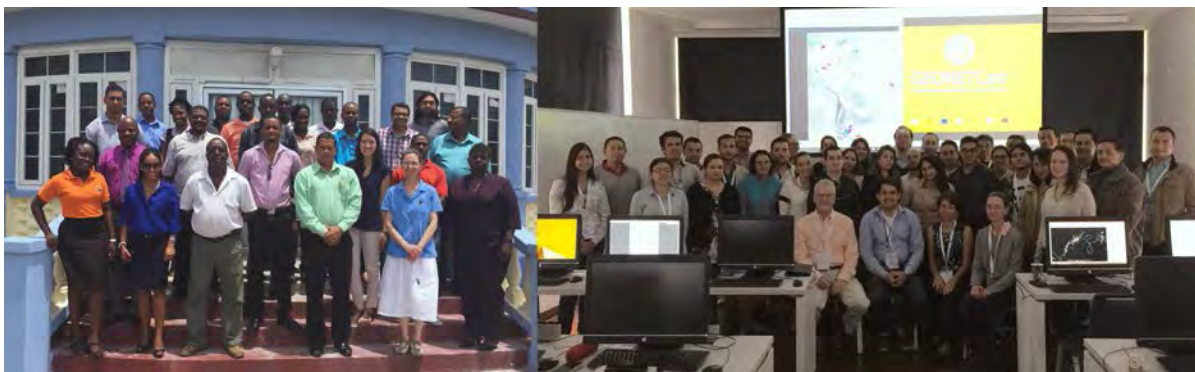

Figure 12. Participants attending the Satellite Data Training workshop at CIMH in Barbados during 3-6 May (left) and participants attending the AmeriGEOSS: GEONETCast workshop at Universidad Nacional de Colombia in Bogota Colombia during 7-10 June (right).

CIRA integrated GEONETCast Americas (GNC-A) product dissemination information into two workshops that occurred in May and June 2016. The 3-6 May workshop took place in Barbados at the Caribbean Institute of Meteorology and Hydrology and focused on building regional climate capacity in the Caribbean. This GOES-R PG VLab project leveraged travel support from the CIMH project “Programmes for Building Regional Climate Capacity in the Caribbean (<http://rcc.cimh.edu.bb/>). CIRA and CIMH organized and delivered the “Satellite Data Training” workshop.

The 7-10 June workshop took place in Colombia at the National University in Bogota as part of the AmeriGEOSS activities for 2016. GEO-Colombia hosted the event. Funding for travel came from the CIRA SHyMet project.

The products of interest shared between the groups include precipitation estimation, vegetation health, and dust and ash detection. We used the opportunity to give a brief overview of GOES-R to inform on the launch of GOES-R as well as encourage feedback from current and potential users on what GOES-R products are desirable for the GNC-A broadcast. The freely available software McIDAS-V was used to display and interpret either real-time or archive GOES and SEVERI imagery and products to demonstrate the hydroestimator product, simple channel differences for identifying dust, and RGB creation for volcanic ash detection.

Publications:

Gladkova, I., A. Ignatov, F. Shahriar, Y. Kihai, D.W. Hillger, and B. Petrenko, 2016: Improved VIIRS and MODIS SST Imagery. *Remote Sensing*, 8:1, doi:10.3390/rs8010079

Knaff, J.A., C.J. Slocum, K.D. Musgrave, C.R. Sampson, and B. Strahl: 2016: Using routinely available information to estimate tropical cyclone wind structure. *Mon. Wea. Rev.*, in press

Knaff, J.A., C. J. Slocum, K. D. Musgrave, C. R. Sampson, and B. R. Strahl, 2016: Using routinely available information to estimate tropical cyclone wind structure. *Mon. Wea. Rev.* 144:4, 1233-1247. DOI: <http://dx.doi.org/10.1175/MWR-D-15-0267.1>

Line, W.E., T.J. Schmit, D.T. Lindsey, and S.J. Goodman, 2016: Use of Geostationary Super Rapid Scan Satellite Imagery by the Storm Prediction Center. *Wea. Forecasting*, 31, 483-494. doi: <http://dx.doi.org/10.1175/WAF-D-15-0135.1>

Miller, S. D., T.J. Schmit, C. Seaman, D. Lindsey, M. Gunshor, R. Kors, Y. Sumida, and D. Hillger, 2016: A Sight for Sore Eyes: The Return of True Color Imagery to Geostationary Satellites. *Bull. Amer. Meteor. Soc.*, 97(10). doi:10.1175/BAMS-D-15-00154.1. NOTE: BAMS Cover Article

Presentations:

Bikos, D., S. Lindstrom, S. Bachmeier, E. Szoke, B. Connell, E. Dagg, B. Ward, A. Mostek, 2016: VISIT / SHyMet contributions to the Satellite Foundational Course (SatFC-G). Poster, National Weather Association (NWA) Annual Meeting, 10-15 September, Norfolk, Virginia.

Bikos, D., and S. Lindstrom, 2016: Status of recent / near future VISIT / SHyMet as it relates to the Satellite Foundational Course for GOES-R (SatFC-G). NOAA Satellite Proving Ground / User Readiness Week, 9-13 May 2016, Norman, Oklahoma.

Bikos, D., D. Lindsey, and E. Szoke: Remote presentations for SOO GOES-R prep workshop in Kansas City, MO on the following dates in 2016: 17 November and 8 December, and in 2017: 12 January, 2 and 24 February, 9 and 23 March.

Bikos, D. and J. Torres: Training on the Weather Event Simulator (WES-2) provided for the Experimental Products Development Team at CIRA, 9 December 2016.

Brummer, R., S. Miller, C. Seaman, D. Lindsey, 2016: Satellite Algorithm Development at CIRA. Colorado Federal Laboratory, Board of Directors, Visit to CIRA, 1 September 2016.

Brummer, R., S. D. Miller, D. Lindsey, C. Seaman, E. Szoke, A. Schumacher, and J. Torres, 2016: GOES-R and JPSS Satellite Proving Ground Activities at CIRA. 2016 EUMETSAT Meteorological Satellite Conference, Darmstadt, Germany, 26-30 September 2016.

Connell, B. 2017: NOAA's Contributions to International Activities for Training in Satellite Meteorology via the WMO VLab. *JPSS Science Seminar Series*, 18 January. Virtual Presentation.

Connell, B., D. Bikos, S. Lindstrom, J. Torres, E. J. Szoke, E. L. Dagg, A. B. Schumacher, A. S. Bachmeier, A. Mostek, B. C. Motta, M. Davison, and L. Veeck, 2017: Satellite user readiness through training: VISIT, SHyMet, WMO VLab and liaisons. 13th Annual Symposium on New Generation Operational Environmental Satellite Systems, Seattle, WA, Amer. Meteor. Soc., 23-26 January 2017, Talk.

Connell, B., 2016: New Satellite Sensors and capabilities: GOES-R and JPSS-1. Training Workshop on Satellite Data. Caribbean Institute for Meteorology and Hydrology, St. James, Barbados, 3-6 May.

Connell, B., and R. Alfaro, 2016: Satellite overview: Current GOES vs GOES-R & current Polar products vs. next generation JPSS-1. GEONETCast Americas Workshop. Universidad Nacional de Colombia, Bogotá, Colombia, 7-10 June.

Connell, B., D. Bikos, S. Lindstrom, E.J. Szoke, S. Bachmeier, J. Torres, E. Dagg, T. Mostek, B. Motta, M. Davison, and L. Veeck, 2016: Satellite User Readiness Through Training: VISIT, SHyMet, and WMO VLab. AMS 21st Satellite Meteorology Conference, Madison, WI, 15-19 August.

Connell, B., L. Veeck, M. Davison, K.-A. Caesar, and V. Castro, 2017: The Impact of Regional Focus Group (RFG) Activities on the Use of Current Satellite Data and Images by Meteorological Personnel with Implications for New Satellite Use. 13th Annual Symposium on New Generation Operational Environmental Satellite Systems, Seattle, WA, Amer. Meteor. Soc., 23-26 January.

Jurewicz Sr., M. L., C. M. Gitro, S. J. Kusselson, J. M. Forsythe, A. S. Jones, S. Kidder, D. Bikos, and E. J. Szoke, 2017: Synoptic comparison of two high-impact predecessor rainfall events: Tropical Storm Lee/Hurricane Katia of September 2011 and Hurricane Joaquin of October 2015. AMS 28th Conference on Weather and Forecasting/24rd Conference on Numerical Weather Prediction, Seattle, Amer. Meteor. Soc., 23-26 January 2017.

Miller, S. D., 2016: Himawari-8. Science presentation for visitors of Chengdu University of Information Technology, China. Meeting held at CSU, Lory Student Center, Fort Collins, CO, July 2016.

Miller, S. D., D. T. Lindsey, C. J. Seaman, T. J. Schmit, M. M. Gunshor, D. W. Hillger, Y. Sumida, 2016: Himawari-8 AHI Proves “Instrumental” in Preparations for Enhanced GOES-R ABI Imagery Applications. **Joint** 21st AMS Satellite Meteorology, Oceanography, and Climatology Conference, Madison, WI, 15-18 August, 2016.

Miller, S.D., 2016: Satellite Research and Application Development at CIRA. NOAA/NESDIS CoRP Science Symposium, CIRA Science Project Overview. CIRA Executive Board Meeting, Fort Collins, CO, May 2016.

Miller, S. D., D. Lindsey, C. Seaman, T. Schmit, M. Gunshor, D. Hillger and Y. Sumida: Anticipating GOES-R ABI Multi-spectral Imagery Capabilities via Himawari-8 AHI. 2016 EUMETSAT Meteorological Satellite Conference, Darmstadt, Germany, 26-30 September 2016.

Schumacher, A.B., 2016: National Hurricane Center Proving Ground Activities. OCONUS Technical Interchange Meeting, Honolulu, HI, 28-30 June 2016.

Seaman, C.J., G. Chirokova, J. Dostalek, L. Grasso, J. Knaff, D. Lindsey, S. Miller and A. Schumacher, 2016: Satellite Proving Ground OCONUS Activities at CIRA. Invited oral presentation. 2015 OCONUS Technical Interchange Meeting, Anchorage, AK, 12-15 May 2016.

Seaman, C., D. Lindsey, S. Miller, J. Knaff, G. Chirokova, J. Dostalek, A. Schumacher, K. Musgrave, L. Grasso, J. Forsythe, R. DeMaria, D. Molenaar, 2016: CIRA/RAMMB Research Activities in Support of the OCONUS. 2016 OCONUS Technical Interchange Meeting, Honolulu, HI, 28-30 June 2016. Invited oral presentation.

Seaman, C. J., S. D. Miller, D. T. Lindsey, D. W. Hillger, 2016: Multi-spectral Imagery for the New Generation Geostationary Satellites: Applications for AHI, ABI and AMI. Australia-Oceania Meteorological Satellite User's Conference (AOMSUC), held jointly with the Korean Meteorological Administration (KMA) Satellite User's Conference, 24-27 October 2016, Incheon, South Korea.

Seaman, C., S. Miller, D. Lindsey and D. Hillger: Multi-spectral applications and RGB composites for the new generation geostationary weather satellites. Yonsei University, Seoul, South Korea, 28 October 2016. Invited seminar presentation.

Seaman, C. J., S. D. Miller, D. T. Lindsey and D. W. Hillger: JPSS and GOES-R Multispectral Imagery Applications and Product Development at CIRA. 97th AMS Annual Meeting, Seattle, WA, 22-26 January 2017. Poster presentation.

Szoke, E., D. Bikos, R. Brummer, H. Gosden, D. Molenaar, D. Hillger, S. Miller, D. Lindsey, B. Connell and C. Seaman, 2016: CIRA's current and future contributions to the GOES-R Proving Ground as we approach the launch of GOES-R. AMS 21st Satellite Meteorology Conference, Madison, WI, 15-19 August.

Szoke, E., D. Bikos, R. Brummer, H. Gosden, D. Molenaar, D. Hillger, S. Miller, D. Lindsey, J. Tores and C. Seaman, 2016: What happens next for CIRA's NWS Proving Ground activities after the launch of GOES-R. 41st NWA Annual Meeting, Norfolk, VA, 12-15 September.

Szoke, E., S. G. Benjamin, C. R. Alexander, E. P., J. M. Brown and S. Weygandt, 2016: The latest on the HRRR model after a recent upgrade. 41st NWA Annual Meeting, Norfolk, VA, 12-15 September.

Seaman, C. J., S. D. Miller, W. C. Straka III, 2016: Illuminating the Capabilities of the VIIRS Day/Night Band in the High Latitudes. 2016 EUMETSAT Meteorological Satellite Conference, Darmstadt, Germany, 26-30 September 2016.

Szoke, E.J., 2016: Talks on GOES-R Proving Ground updates at the Boulder Weather Forecast Office (WFO) Winter Workshops on 30 September & 7 October 2016.

Szoke, E.J., 2016: Talk on GOES-R Proving Ground updates at the Cheyenne Weather Forecast Office (WFO) on 1 December 2016.

Szoke, E., D. Bikos, R. Brummer, H. Gosden, D. Molenaar, D. Hillger, S. Miller, D. Lindsey, J. Tores and C. Seaman, 2017: CIRA's contribution to the NWS Proving Ground: A look back at pre-launch activities and a look ahead to post-launch interactions. 13th Annual Symposium on New Generation Operational Environmental Satellite Systems, Seattle, WA, Amer. Meteor. Soc., 23-26 January 2017.

Ward, B., A. Mostek, R. Van Til, L. Spayd Jr., F. W. Alsheimer, M. T. Stavish, D. Nietfeld, B. C. Carcione, N. Eckstein, W. Abshire, P. Dills, G. T. Stano, J. G. LaDue, M. A. Bowlan, D. Bikos, B. H. Connell, E. Szoke, E. L. Dagg, S. Bachmeier, S. Lindstrom, J. Gerth, and T. Schmit, 2017: The Satellite Foundational Course for GOES-R: A collection of lessons to prepare National Weather Service forecasters for GOES-R. AMS 28th Conference on Weather and Forecasting/24rd Conference on Numerical Weather Prediction, Seattle, Amer. Meteor. Soc., 23-26 January 2017.

PROJECT TITLE: CIRA Support for Development and Evaluation of JPSS-1 Based Tropical Cyclone Intensity and Structure Estimates

PRINCIPAL INVESTIGATORS: Jack Dostalek and Galina Chirokova

RESEARCH TEAM: Scott Longmore, Robert DeMaria

NOAA TECHNICAL CONTACT: Satya Kalluri (NOAA/NESDIS) and Liqun Ma (NOAA/NESDIS)

NOAA RESEARCH TEAM: John Knaff (NOAA/NESDIS/STAR/RAMMB)

FISCAL YEAR FUNDING: \$83,700

PROJECT OBJECTIVES:

Tropical cyclones (TCs) tend to develop and spend a significant portion of their lifecycle over tropical oceans, out of range of aircraft reconnaissance and where in situ observations are sparse. In these regions, meteorologists must rely on satellites to provide data to initialize atmospheric models and to monitor TC motion and intensity. Satellite microwave sounders have proven especially useful for these tasks, since they can be used in the presence of cloud cover. The Regional and Mesoscale Meteorology Branch (RAMMB) at CIRA has developed products that use temperature profiles derived from microwave radiances measured from polar-orbiting satellites in conjunction with boundary conditions from the GFS model and TC location fixes to estimate TC intensity and structure. In a previous PSDI project, upgrades

to the intensity and structure algorithms were successfully transitioned to operations. These upgrades included the transition from the use of a statistical retrieval algorithm to employing the Microwave Integrated Retrieval System (MIRS) for computing the temperature profiles. In addition, the TC intensity and structure code can now process retrievals from the AMSU's successor, the Advanced Technology Microwave Sounder (ATMS), which flies aboard NOAA's newest polar-orbiting satellite, the Suomi National Polar-orbiting Partnership (S-NPP) satellite. Tropical cyclones are now monitored worldwide by four satellites using AMSU/MIRS retrievals: NOAA-18, NOAA-19, MetOp-A, and MetOp-B, and one satellite using ATMS/MIRS retrievals: S-NPP. In the Fall of 2017, the next satellite in NOAA's polar-orbiting series will be launched, JPSS-1, which carries a payload similar to that aboard S-NPP, including the ATMS. The tasks of this project are to further modify the tropical cyclone intensity and structure code to be able to process data from JPSS-1.

Specific objective this reporting period include 1) Participation in the Critical Design Review, 2) Updating the code to process JPSS-1 data, 3) Preparing setup for parallel runs at CIRA, and 4) User interaction.

PROJECT ACCOMPLISHMENTS:

1--Critical Design Review

The first step in preparing updated code for transition to NESDIS' operations is the Critical Design Review. The Critical Design Review for this algorithm, along with many other algorithms being updated for use with JPSS-1 data occurred on 27 October 2016. The TC intensity and structure code passed the review and is continuing toward operational implementation.

2--Updates to Algorithm

Several updates have been made to the TC intensity and structure algorithm. These updates include not only the necessary modifications to accept JPSS-1 data, but also some streamlining of the existing code to increase performance and flexibility. The code contains a combination of shell scripts, python scripts, and Fortran 90 programs. Figure 1 outlines the flow of the algorithm.

The following updates have been implemented. The updated version of the CIRA Polar Orbiters Database (CPOD) has been included in the updated code. The 1st version of the database software rewrites all input data into a special format, which requires a lot of time and creates multiple issues with reprocessing past cases, a step that is required to update the coefficients for the TC intensity algorithm. The CPOD writes only the metadata to a database, which simplifies the processing and makes it more stable.

In addition, the main TC intensity algorithm ("oparet") has been updated. The updates to "oparet" include creating a single version of the code capable of processing data from different instruments and adding the option to use virtual temperature instead of temperature. The driver scripts have been updated as well to accommodate the above changes. Together these changes make the code much more flexible, and will simplify the expansion of the algorithm to include ATMS-MIRS data from JPSS1.

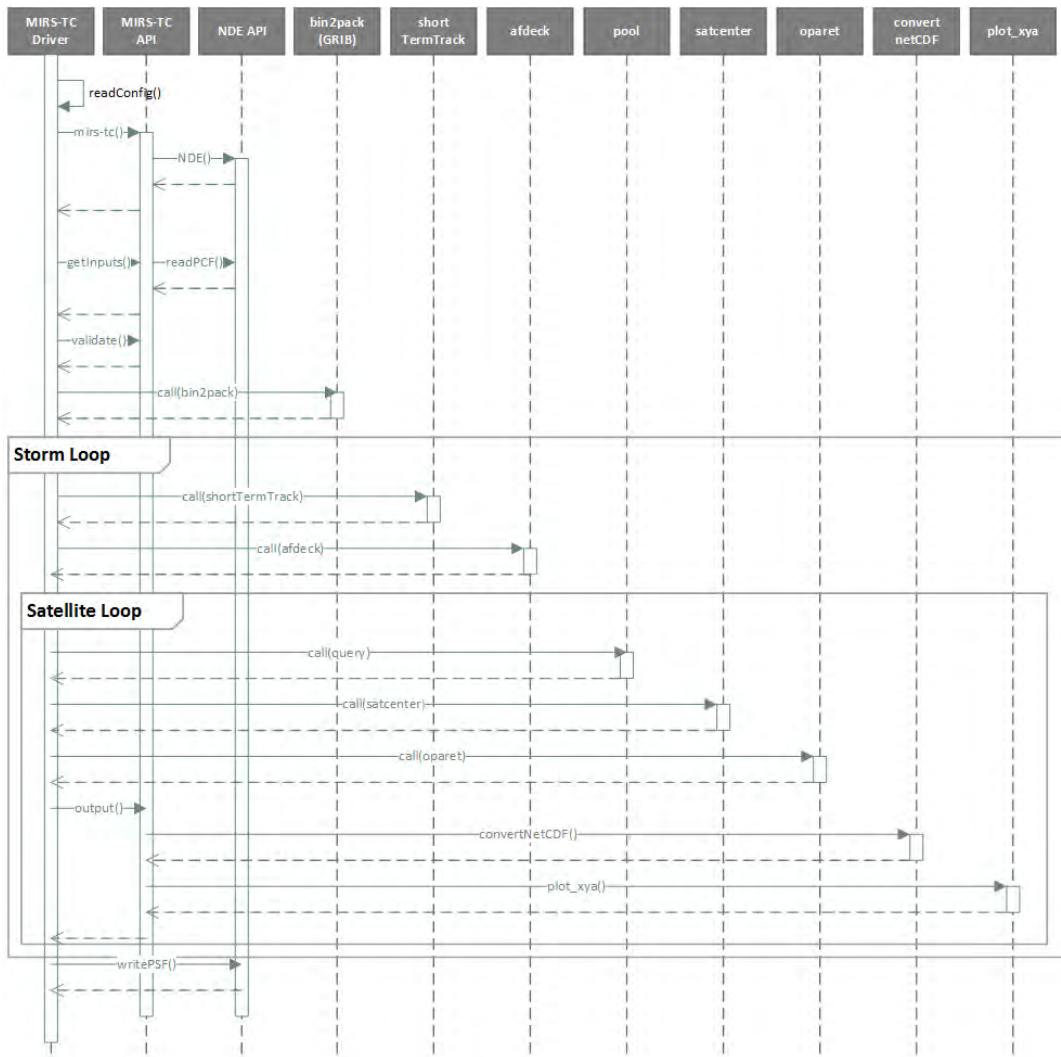

Figure 1. UML sequence diagram outlining the TC intensity and structure algorithm workflow.

3--Setup for parallel runs

The environment has been setup for running the TC structure and intensity code at CIRA. The main goal is to replicate exactly the operational environment to ensure we can reproduce operational runs and quickly resolve any possible issues with the algorithm. The real-time runs of the updated algorithm with the old coefficients and SNPP data will be started by the beginning of 2017 Atlantic and east Pacific hurricane seasons. The runs with proxy J1 data will be started as soon as the proxy data are available from the MIRS developers.

4--User interaction

The TC intensity algorithm and the plans to update were presented at several meetings, including the Proving Ground Review at the National Hurricane Center (NHC) on February 17, 2017. NHC is currently getting the intensity estimates produced by AMSU-MIRS version of the algorithm through the ATCF f-decks. Work is underway on getting estimates from the ATMS-MIRS based algorithm.

Publications: None

Presentations:

Chirokova, G., M. DeMaria, J. Dostalek, R. DeMaria, J. Knaff, and J. Beven, 2016: ATMS-MIRS retrievals in tropical cyclone environments: evaluation and applications. JPSS Science Team Meeting, 8-12 August 2016, College Park, MD.

Chirokova, G., A. Schumacher, and E. Berndt, 2017: JPSS Tropical Cyclone Products. Lecture at the JPSS Short Course at the AMS 97th Annual Meeting, 21 January 2017, Seattle, WA.

Chirokova, G., M. DeMaria, R.T. DeMaria, J. Knaff, J.F. Dostalek, and J.L. Beven, 2017: Use of JPSS ATMS, CrIS, and VIIRS data to improve tropical cyclone track and intensity forecasting. AMS 97th Annual Meeting, 21-26 January 2017, Seattle, WA.

DeMaria M., J. L. Beven, G. Chirokova, E. Dagg, R. DeMaria, J. Knaff and A. Schumacher, 2017: Current and Upcoming Proving Ground Demonstrations at NHC. February 17, 2017, NHC, Miami, Florida.

Dostalek, J., G. Chirokova, J. Knaff, S. Longmore, A. Schumacher, R. DeMaria, and C. Sampson, 2016: Recent and future updates to the operational, satellite-based tropical cyclone products produced at the Cooperative Institute for Research in the Atmosphere. 32nd Conference on Hurricanes and Tropical Meteorology, 19-22 April 2016, San Juan, PR.

PROJECT TITLE: CIRA Support for Dynamical Core Selection for the Next Generation Global Prediction System (NGGPS)

PRINCIPAL INVESTIGATOR: Renate Brummer

RESEARCH TEAM: Renate Brummer, John Thuburn

NOAA TECHNICAL CONTACT: Fred Toepfer (NOAA/NCEP/EMC) and Candice Jongsma (NOAA/OAR)

NOAA RESEARCH TEAM: Fred Toepfer (NOAA/NCEP/EMC)

FISCAL YEAR FUNDING: \$175,000

PROJECT OBJECTIVES:

As part of a Research to Operations (R2O) Initiative, the National Weather Service (NWS) plans to produce a state-of-the art next generation global prediction system (NGGPS) which will be readily adaptable to and scalable on evolving high-performance computing (HPC) architectures. The NGGPS will be designed to produce useful forecast guidance to 30 days, as well as become the foundation for the operating forecast guidance system for the next several decades. Current research and development efforts both inside and outside NWS, including the Navy, NOAA laboratories, National Center for Atmospheric Research (NCAR), the university research community, and other partnership efforts, will contribute to the development of this prediction system.

Selecting a non-hydrostatic atmospheric dynamic core (dycore) was the first step in building the NGGPS. Six dycores currently being developed and modified from a variety of institutions are viewed as potential candidates to be evaluated for the new system. The NGGPS Dycore Testing Plan guided the testing of these dycores and leverage ongoing High-Impact Weather Prediction Project (HIWPP) activities in the evaluation of the dycores.

PROJECT ACCOMPLISHMENTS:

Objective and unbiased assessment of the test and evaluation results is essential to the selection of the future atmospheric model dynamic core for the NGGPS. A Dynamic core Test Group (DTG) was established to conduct this assessment. The DTG assessed the results of NGGPS testing and provided first assessment of the results to NOAA (NWS) management. This assessment, along with business considerations, was used in the development of the business case supporting the selection of the next dycore by NWS management.

The Draft Plan of the DTG called for two levels of testing, with Level 1 completed April 2015 and Level 2 completed March 2016. There was a computational line of testing to be performed by the Advanced Computing Evaluation Committee. After the completion of the prescribed testing suites, the dycores required further testing. This testing included accuracy with operational components (e.g. any future upgrade to physics, data assimilation), opportunities for accuracy tuning and evaluation of computational performance. Emphasis was put on testing under the conditions in which the chosen dycore will eventually operate. Details are still to be determined by the DTG and its sponsors.

John Thuburn, an international recognized expert in this research area from the United Kingdom, participated in this project and has contributed to reports and presentations at all interim and major milestones. These reports were written in Summer 2015 and 2016. The final Dynamical Core Evaluation Test Report was made public in September 2016. The final report recommended that NWS should adopt the FV3 dynamical core for its Next Generation Global Prediction System.

Publications: None

Presentations: None

PROJECT TITLE: CIRA Support for Feature-Based Validation of MIRS Soundings for Tropical Cyclone Analysis and Forecasting

PRINCIPAL INVESTIGATORS: Jack Dostalek and Galina Chirokova

RESEARCH TEAM: Robert DeMaria, Natalie Tourville

NOAA TECHNICAL CONTACT: Satya Kalluri (NOAA/NESDIS)
and Mitch Goldberg (NOAA/NESDIS/JPSS Program)

NOAA RESEARCH TEAM: John Knaff (NOAA/NESDIS/STAR/RAMMB)

FISCAL YEAR FUNDING: \$0

PROJECT OBJECTIVES:

CIRA has been producing analyses of tropical cyclone (TC) intensity and structure based on microwave radiances measured from polar-orbiting satellites for well over a decade. Using knowledge gained from the FY14 CIRA StAR Cal/Val project and with the goal of improving the global utility of MIRS operational TC products, the objective of this work is to further calibrate and correct the ATMS and high-resolution AMSU profiles, as well as the operational TC intensity and structure algorithm (ISATC) using newly created databases. This effort will improve the accuracy of the operational estimates of TC intensity, central pressure and wind radii. Three objectives define this project.

The first objective consists of conducting additional research into improving the ISATC. This includes updating the bias adjustments to the MIRS retrievals. The MIRS algorithm was designed for global use, so some modifications may be necessary when applying them to specific areas, such as tropical cyclones. The second objective involves supplementing our “ground truth” database of dropsonde profiles with radiosondes from island and coastal sites. Including radiosonde data is particularly important in the Pacific, where reconnaissance flights are rare. The final objective is to look into using NUCAPS retrievals in the ISATC. The NUCAPS algorithm combines both microwave and infrared measurements to retrieve profiles of temperature and moisture.

PROJECT ACCOMPLISHMENTS:

1--Develop bias-correction for ATMS/AMSU profiles

The performance of ATMS-MIRS retrievals in the TC environment has been evaluated. It was found that ATMS-MIRS data provide the best temperature and humidity estimates at the center of the storm. The NUCAPS data provide more information beyond 500 km from the storm center. A bias-correction for ATMS-MIRS data has been developed based on comparison with dropsondes. The MIRS versions are regularly updated, and the bias-correction developed on a limited sample size using a specific version of MIRS will not work for future data. For that reason it was decided that the bias-corrected version should not be implemented in operations. A publication describing the results of this evaluation is in preparation.

2--Test the ISATC algorithm with NUCAPS input

The NUCAPS data were evaluated in the TC environment as well. It was found that many NUCAPS soundings close to the TC center do not pass quality control, which is reasonable since NUCAPS is using IR data from CrIS. Figure 1 shows the azimuthally averaged vertical temperature profile for Hurricane Edouard, al062014, calculated from AMSU-MIRS (left) and NUCAPS (right) retrievals. The NUCAPS data shows a very significant, but unrealistic cold anomaly at the middle-and lower- levels. Overall, the NUCAPS soundings close to the TC center provide less information about the vertical temperature structure than the ATMS-MIRS or AMSU-MIRS soundings. Therefore, NUCAPS soundings are best suited for diagnosing the storm environment; they do not currently add value to the TC-intensity algorithm that relies heavily on the inner core data.

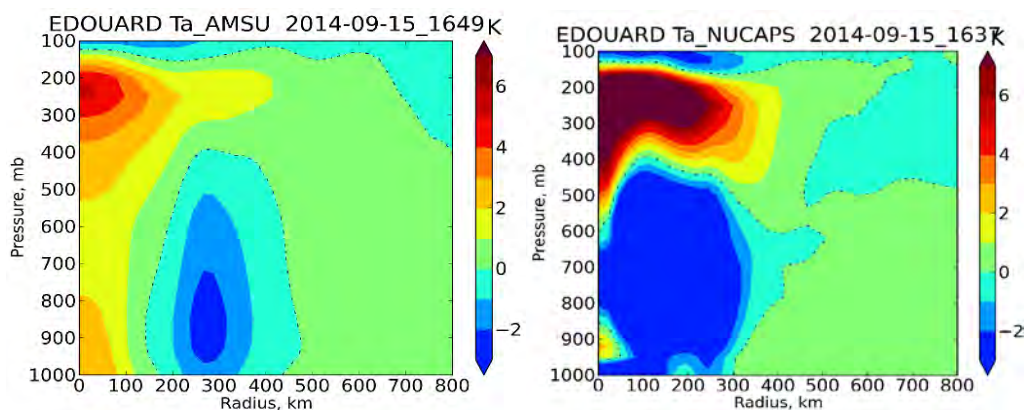

Figure 1. Azimuthally-averaged temperature profiles for Hurricane Edouard, al062014, calculated from AMSU-MIRS (left) and NUCAPS (right) retrievals.

Publications: None

Presentations:

Chirokova, G., M. DeMaria, J. Dostalek, R. DeMaria, J. Knaff, K. Musgrave, and J. Beven, 2016: Evaluation of the ATMS-MIRS and NUCAPS retrievals in the vicinity of tropical cyclones. 32nd Conference on Hurricanes and Tropical Meteorology, 19-22 April 2016, San Juan, PR.

Chirokova, G., M. DeMaria, J. Dostalek, R. DeMaria, J. Knaff, and J. Beven, 2016: ATMS-MIRS retrievals in tropical cyclone environments: evaluation and applications. JPSS Science Team Meeting, 8-12 August 2016, College Park, MD.

Dostalek, J., G. Chirokova, J. Knaff, S. Longmore, A. Schumacher, R. DeMaria, and C. Sampson, 2016: Recent and future updates to the operational, satellite-based tropical cyclone products produced at the Cooperative Institute for Research in the Atmosphere. 32nd Conference on Hurricanes and Tropical Meteorology, 19-22 April 2016, San Juan, PR.

PROJECT TITLE: CIRA Support to Improving CRTM Solar Reflection

PRINCIPAL INVESTIGATOR: Louie Grasso

RESEARCH TEAM: Yoo-Jeong Noh, Renate Brummer, Kevin Micke

NOAA TECHNICAL CONTACT: Satya Kalluri (NOAA/NESDIS) and Fuzhong Weng (NOAA/NESDIS)

NOAA RESEARCH TEAM: Dan Lindsey (NOAA/NESDIS/STAR/RAMMB)

FISCAL YEAR FUNDING: \$0

PROJECT OBJECTIVES:

The Cooperative Institute for Research in the Atmosphere (CIRA) together with the NOAA/NESDIS/StAR Regional and Mesoscale Meteorology Branch (RAMMB) have extensive experience using the Community Radiative Transfer Model (CRTM). A year ago, the CIRA/RAMMB synthetic imagery team noticed some significant errors (~50 K for the 3.9 μm band) in the CRTM solar reflective bands for clouds, particularly ice clouds. This was brought to the attention of the NESDIS/StAR CRTM team who looked into it and verified that the error exists. It was decided that the way reflection of solar radiation by clouds is handled in the CRTM needs to be overhauled. What the CRTM had was built on an original framework of clear sky, single line-of-sight radiative transfer with an effectively specular surface.

The CIRA/RAMMB team has extensive previous experience with solar scattering radiative transfer, after having developed a Radiative Transfer Model (RTM) that extends from visible wavelengths into the infrared over the last many years. Specifically, the RTM can successfully simulate the 3.9 μm band by using solar scattering lookup tables in a routine called SHDOM (developed by Frank Evans). The tables originated from Ping Yang's (Texas A&M) solar scattering lookup tables.

In close collaboration with the NESDIS/StAR CRTM team members Tong Zhu, Mark Liu and Paul van Delst, the source of the error at 3.9 μm in the CRTM code was identified. Based on a several teleconferences the CIRA/RAMMB team and the CRTM developers agreed on the following tasks to be conducted by the CIRA/RAMMB team:

1--Compare the Ping Yang lookup tables and associated solar scattering calculations between the CRTM and CIRA's SHDOM routine.

2--Identify where in the CRTM code the error in the computation of the CRTM brightness temperature at 3.9 μm is occurring, and then determine what needs to be done in order to fix the error.

3--Depending on the nature of the problem, either update CRTM LUTs/fix CRTM code following the CRTM coding and performance guidelines **or** demonstrate an accurate result with a combined CRTM-SHDOM method.

PROJECT ACCOMPLISHMENTS:

1--Synthetic imagery was produced from a WRF-ARW simulation that used the Thompson microphysics. In one case, synthetic imagery was calculated with the CRTM_v2.1.3 that uses scattering lookup tables that are generated by Ping Yang's group at Texas A&M (Fig. 1b). In another case, synthetic imagery was calculated with the CIRA RTM that uses SHDOM and associated lookup tables (Fig. 1c). Observations (Fig. 1a) highlights the lack of solar reflection from the CRTM_v2.1.3 while supporting the results from the CIRA R

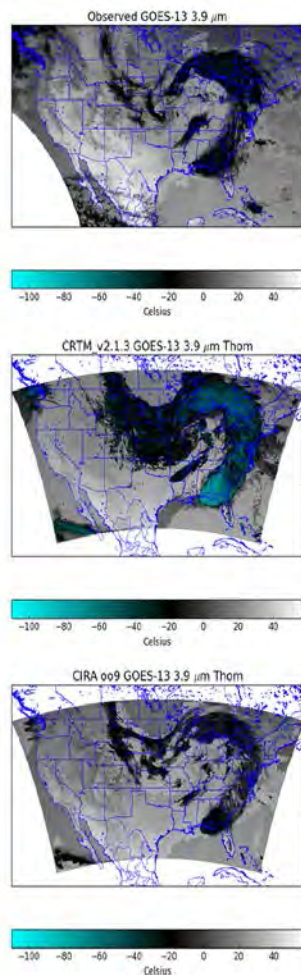

Figure 1. Comparisons between

(a) Observed GOES-13 3.9 μm (top figure),
(b) CRTM (V2.1.3) with a lack of solar reflection (center figure), and
(c) CIRA oo9 for 29 April 2014 at 18 Z (bottom figure). Compared to the CRTM, CIRA oo9 results are supported by observations. Both (b) and (c) are based on a WRF-ARW simulation that employed the Thompson microphysics.

2--Together with the NESDIS CRTM developer team a coding error was located in routine ADA_Module.f90, line 448'ish, in version 2.1.3. Below is a summary.

Original: "if (RTV%Visible_Flag_true) then"
was replaced by the following Fix:
Fix: " if (RTV%Solar_Flag_true) then"

Further, the delta-fitted Legendre coefficients that are used to describe the Legendre Phase Function of pristine ice were in error in the cloud coefficient lookup table. This table is in the file CloudCoeff.bin version 3.04. An example of a set of six-stream coefficients that resulted from a quadratic interpolation in four wavelengths and four effective radii are the following:

Term l=:	1	pcoeff(l,m,kc,n):	-2.141713177739546E-002
Term l=:	2	pcoeff(l,m,kc,n):	-3.569515777398292E-002
Term l=:	3	pcoeff(l,m,kc,n):	-3.604496566266741E-002
Term l=:	4	pcoeff(l,m,kc,n):	-9.854570003897810E-002
Term l=:	5	pcoeff(l,m,kc,n):	-9.992454293002201E-002
Term l=:	6	pcoeff(l,m,kc,n):	1.405910709521107E-002

An updated CloudCoeff.bin version 3.07 was provided by the CRTM team that contained correct values. The updated set of Legendre coefficients of pristine ice from above then became the following:

Term l=:	1	pcoeff(l,m,kc,n):	0.840471362872913
Term l=:	2	pcoeff(l,m,kc,n):	0.904354761761248
Term l=:	3	pcoeff(l,m,kc,n):	0.725027547657389
Term l=:	4	pcoeff(l,m,kc,n):	0.477582211656941
Term l=:	5	pcoeff(l,m,kc,n):	0.176536461781458
Term l=:	6	pcoeff(l,m,kc,n):	0.705481548343187

In order to evaluate the values of the Legendre coefficients of pristine ice in the CloudCoeff.bin version 3.07, a comparison was made with Legendre coefficients that were used by the CIRA RTM (Fig. 1c). Although the CIRA RTM uses approximately 2500 Legendre coefficients, a technique was applied to extract the corresponding values for a six-stream approximation. Results of the comparison exhibited similar values between the CRTM and CIRA.

In summary, the above discussion applies only to the microphysical habit called pristine ice. As a result, we have communicated with Paul van Delst, via a telecom, our findings and recommendation thus far: Due to the relatively coarse spacing of the data in CloudCoeff.bin, we suggested reducing both the spacings between wavelengths and effective radii. That is, increase the resolution of the optical properties in the lookup table.

Brightness temperatures at 3.9 μm also exhibit discrepancies between the CRTM and observations. We are currently working on this issue.

3--Depending on the nature of the CRTM problem, the CIRA team was tasked to either update CRTM LUTs/fix CRTM code following the CRTM coding and performance guidelines **or** demonstrate an accurate result with a combined CRTM-SHDOM method. The CIRA Team took the following action:

- We have included the code error that was outlined in ADA_Module.f90.
- We have pass along recommendations for updating the CRTM LUT for pristine ice.
- We updated the CRTM via a telecom in late January 2016 after which Paul van Delst send the following comment: *"Let me end by reiterating my thanks to you all at CIRA for doing this. Your work there will make a big difference in how well the CRTM, indeed *any* RT model, can simulate cloudy radiances"*.

The final CRTM task left for the CIRA Team is to investigate any CRTM cloud liquid water issues.

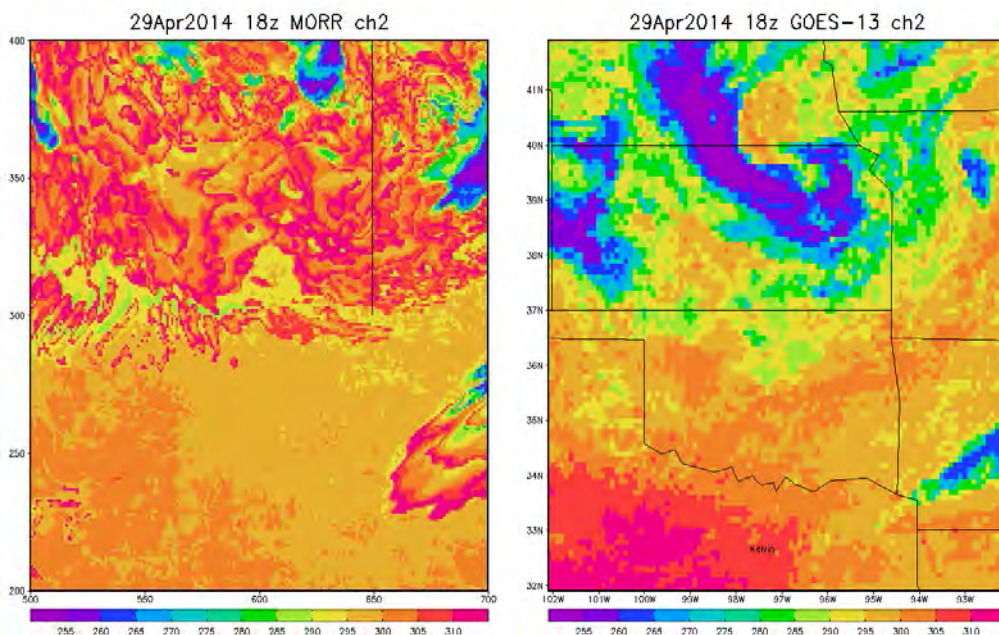

Figure 2. Synthetic (left) and observed (right) GOES-13 imagery at 3.9 of the liquid water cloud in the central plains. Observations does not support CRTM generated brightness temperatures of the liquid water cloud layer. Black vertical line at $x=650$ (left) is the location of a vertical cross section to be shown next. Liquid water cloud drop sizes may be too small over central plains thus leading to unrealistically large brightness temperatures at 3.9 μm .

Publications: None

Presentations:

Grasso, L., D. Lindsey, Y-J Noh, and C. O'Dell, 2016: Improving CRTM Solar Reflection at 3.9 μm . 14th Technical Review Meeting and Science Workshop on Satellite Data Assimilation, 31 May-2 June, 2016, Monterey, California

Grasso, L., D. Lindsey, Y-J Noh, and C. O'Dell, 2016: Improving CRTM Solar Reflection at 3.9 μm . Visit to the Naval Research Laboratory, June, 2016, Monterey, California

Grasso, L., 2016: Synthetic Satellite Imagery. Invited speaker at the University of Utah, Salt Lake City, Utah, 21 October 2016,

Lindsey, D.T., L.D. Grasso, Y-J Noh, 2016: Improvements to the CRTM for Cloudy Radiance Calculations. 4th Annual Symposium on the Joint Center for Satellite Data Assimilation (JCSDA), 96th AMS Annual Meeting, 10-14 January 2016, New Orleans, LA.

PROJECT TITLE: CIRA Support to the JPSS Proving Ground and Risk Reduction Program: Addressing NWS Desires for a Cloud Cover Layers Product using Merged VIIRS and ATMS Products

PRINCIPAL INVESTIGATOR: Steve Miller

RESEARCH TEAM: Yoo-Jeong Noh, Curtis Seaman, John Forsythe, Steve Finley, Renate Brummer

NOAA TECHNICAL CONTACT: Satya Kalluri (NOAA/NESDIS) and Andy Heidinger (NOAA/NESDIS)

NOAA RESEARCH TEAM: Dan Lindsey (NOAA/NESDIS/STAR/RAMMB)

FISCAL YEAR FUNDING: \$0

PROJECT OBJECTIVES:

This project is collaboration between Andrew Heidinger of NOAA/NESDIS/STAR/ASPB and his colleagues at the Cooperative Institute for Meteorological Satellite Studies (CIMSS) and the Cooperative Institute for Research in the Atmosphere (CIRA), led by Steve Miller on the CIRA side. The ultimate goal was to address key challenges articulated by the National Weather Service (NWS) with regard to Cloud cover and layers (CCL). The requirement was for improved plan-view imagery at 2 km spatial resolution reporting the presence of cloud, its classification, and an estimation of its phase at selected flight levels.

The CIRA team assisted CIMSS in the exploitation of Day/Night Band by supplying updated version of its lunar irradiance model for use in CLAVR-x cloud retrievals. Retrieval of cloud optical depth at night is enabled by the high sensitivity of visible light reflectance (in this case, moonlight), which requires the assistance of the lunar model to determine. In order to calculate the cloud geometric thickness (CGT) the CIRA team derived the cloud optical depth, particle size, and the cloud water path. The cloud water path was used to estimate cloud geometric thickness—a key parameter for an augmented CCL application.

- 1--Continue development of cloud geometric thickness (CGT) retrieval algorithm
- 2--Continue Initial CCL development and visualization
- 3--Implementation and demonstration of the CCL Application for AWC (Alaska and Hawaii). Work directly with respective point of contacts and use feedback to improve CCL
- 4--Begin work on extension of CCL to Nighttime VIIRS Data

PROJECT ACCOMPLISHMENTS:

1--The statistical CBH/CGT algorithm developed by CIRA by using A-Tran satellite data has been implemented with support from CIMSS colleagues and successfully run in the Clouds from AVHRR Extended (CLAVR-x) processing system. The NESDIS/STAR Algorithm Scientific Software Integration and System Transition Team (ASSISTT) is testing the algorithm in the operational environment. A few modifications of the algorithm codes have been implemented to improve error flags and the cloud base calculation for deep convective clouds. Two journal papers on the VIIRS cloud base algorithm validation and development have been published this year.

2--In collaboration with the CIMSS team, the CGT information from the CBH algorithm was added to improve the current CCL algorithm embedded in the CLAVR-x system. The old algorithm employs the cloud top information only. Figure 1 shows an example (at 1202 UTC on 11 May 2016 over central Africa) of the improved VIIRS layer cloud fractions implemented at CIRA into AWIPS II. The addition of the new cloud base information from the CGT retrieval can enhance lower cloud layer fractions often missed by the old CCL retrieval.

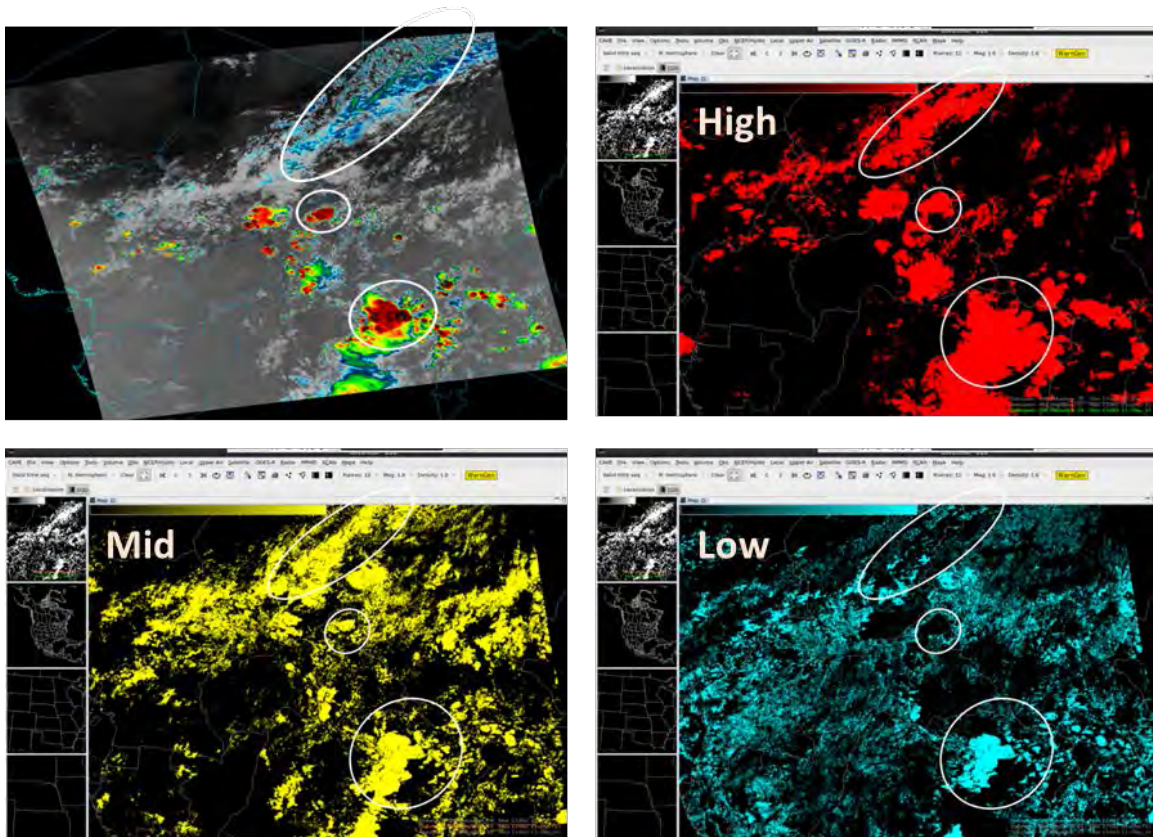

Figure 1. Example display of VIIRS Cloud Cover Layers products implemented at CIRA into AWIPS II (top left: VIIRS I-band 5 image).

3--The improved CCL algorithm has been applied to VIIRS. The CLAVR-x system with the new CCL algorithm has been run in near time at CIRA, targeting the Alaska region. This product is distributed to the Aviation Weather Center (AWC). We have received feedback about our products from AWC Satellite Liaison Amanda Terborg and discussed potential collaborations for the algorithm improvement. The same approach has been applied to Himawari-8 AHI and also showed potential to obtain enhanced CCL products.

4--Lunar reflectances from VIIRS DNB have been utilized for nighttime cloud optical properties to calculate CGT. Figure 2 shows a sample result of the layered cloud fractions over Alaska from the new CCL retrieval. Nighttime cloud optical properties for CWP to retrieve CGT and CCL are retrieved using lunar reflectances from VIIRS DNB data with supplementary NWP data. The initial validation results using ground-based measurements over Alaska (polar winter in 2015-2016) were presented at the AGU annual meeting. We will collaborate with Andrew Heidinger and his development team to merge VIIRS and ATMS data for improvement of the CWP retrieval.

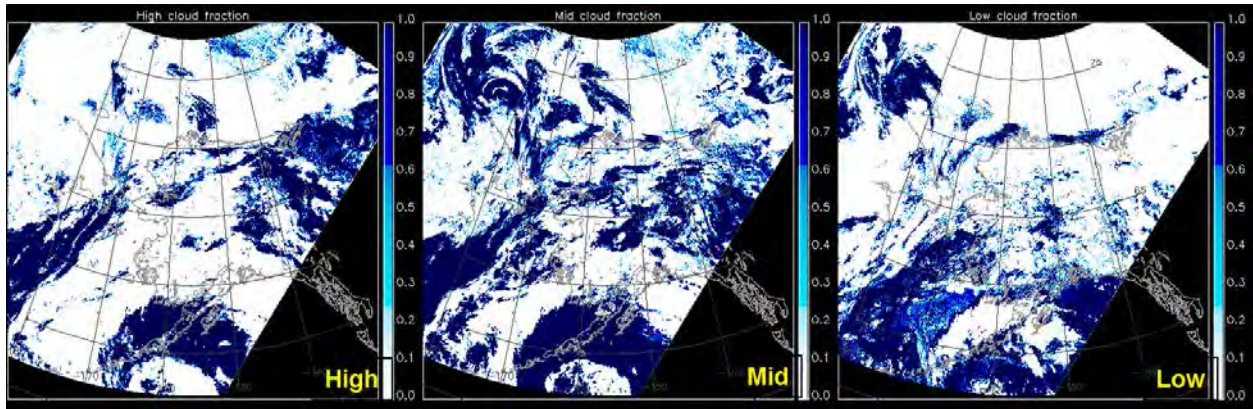

Figure 2. Sample of VIIRS layered cloud fractions over Alaska from the improved CCL algorithm using the cloud base information (1351-1401 UTC on 29 February 2016).

Publications:

Noh, Y. J., J. M. Forsythe, S. D. Miller, C. J. Seaman, Y. Li, A. K. Heidinger, D. T. Lindsey, M. A. Rogers, and P. T. Partain, 2017: Cloud base height estimation from VIIRS. Part II: A statistical algorithm based on A-Train satellite data. *J. Atmos. Ocean. Tech.*, doi: 10.1175/JTECH-D-16-0110.1.

Seaman, C. J., Y. J. Noh, S. D. Miller, A. K. Heidinger, and D. T. Lindsey, 2017: Cloud base height estimation from VIIRS. Part I: Operational algorithm validation against CloudSat. *J. Atmos. Ocean. Tech.*, doi: 10.1175/JTECH-D-16-0109.1.

Presentations:

Heidinger, A. K., A. Walther, D. T. Lindsey, Y. Li, Y. J. Noh, D. Botambekov, S. D. Miller, and M. J. Foster, 2016: Improvements in Cloud Remote Sensing from Fusing VIIRS and CrIS data. 2016 AGU Fall Meeting, San Francisco, CA, 12-16 December 2016.

Noh, Y. J., 2016: Use of satellite and in-situ observations for evaluating and improving the representation of cloud processes in NWP models. 4th International workshop on next-generation NWP models: gray-zone and advanced approaches for high-impact weather, Jeju, Korea, 25-27 May 2016.

Noh, Y. J., S. D. Miller, J. M. Forsythe, C. J. Seaman, D. T. Lindsey, A. K. Heidinger, and Y. Li, 2016: The newly operational VIIRS Cloud Base and CCL (Cloud Cover/Layers). STAR JPSS Annual Science Team Meeting, College Park, MD, 8-12 August 2016.

Noh, Y. J., S. D. Miller, C. J. Seaman, J. M. Forsythe, D. T. Lindsey, A. K. Heidinger, and Y. Li, 2016: Improvement of satellite Cloud Base Height and Cloud Cover/Layers products. 7th Asia-Oceania/2nd AMS-Asia/2nd KMA Meteorological Satellite Users' Conference, Songdo City, Incheon, Korea, 21-28 October 2016.

Noh, Y. J., S. D. Miller, C. J. Seaman, J. M. Forsythe, R. Brummer, D. T. Lindsey, A. Walther, A. K. Heidinger, and Y. Li, 2016: Validation of VIIRS cloud base heights at night using ground and satellite measurements over Alaska. 2016 AGU Fall Meeting, San Francisco, CA, 12-16 December 2016.

PROJECT TITLE: CIRA Support for the JPSS Proving Ground and Risk Reduction Program: Application of Joint Polar Satellite System (JPSS) Imagers and Sounders to Tropical Cyclone Track and Intensity Forecasting

PRINCIPAL INVESTIGATOR: Galina Chirokova

RESEARCH TEAM: Robert DeMaria, Jack Dostalek, Andrea Schumacher

NOAA TECHNICAL CONTACT: Satya Kalluri (NOAA/NESDIS)
and Mitch Goldberg (NOAA/NESDIS/JPSS Program)

NOAA RESEARCH TEAM: John Knaff (NOAA/NESDIS/STAR)

FISCAL YEAR FUNDING: \$150,000

PROJECT OBJECTIVES:

The ability to forecast tropical cyclone (TC) intensity changes has improved much more slowly than the ability to forecast TC tracks. An especially difficult but very important forecast problem is predicting rapid increases in TC intensity, that is Rapid Intensification (RI). Improving RI forecasts is one of the highest priorities within NOAA. The time scale of TCs' track and intensity changes is on the order of 12 hours, which makes the JPSS instruments well suited for the forecasting of these parameters. Several TC applications of JPSS data using S-NPP ATMS, CrIS, and VIIRS data are being developed. The first group of applications uses ATMS-MIRS and NUCAPS retrievals to improve the Rapid Intensification Index (RII). JPSS data will be used to develop new predictors for the RII as well as to improve existing predictors. As part of the development of the new predictors for the RII, two additional end user applications are being developed: (1) the moisture flux application that will allow for the detection of dry air intrusions that are an important factor for forecasting intensity; and (2) the improved eye-detection application. The objective automated eye-detection algorithm is being improved by using VIIRS data and ancillary data, and will be adapted to be used as an additional predictor in the RII. The newly developed and improved predictors developed here will be incorporated into the NHC's operational RII to improve its performance. The second group of applications develops tools to better utilize VIIRS imagery, especially VIIRS DNB imagery, for TC forecasting, and will include a proxy-visible imagery application and improved TC VIIRS DNB imagery.

The newly developed products will be made available via the satellite Proving Ground to operational forecasters at the National Hurricane Center (NHC) and the Joint Typhoon Warning Center (JTWC) for evaluation and feedback. If the evaluation is positive, the products can be transitioned to NHC and JTWC operations.

PROJECT ACCOMPLISHMENTS:

1--New CIRA Polar-Orbiters Database (CPOD) software for efficient selection of TC data from global S-NPP data

Many JPSS tasks require the ability to select data around a TC (or other point of interest) at a particular time. The basic version of the improved software for efficient selection of TC data from global S-NPP data, the CPOD, has been developed. As part of the previous JPSS-TC project, software was developed to perform selection by re-writing ATMS-MIRS (or similarly formatted data such as AMSU-MIRS) in a searchable database. However, several of the JPSS tasks require the use of a variety of data sources, each with different formats. Additionally, each task may require slight variations in the algorithm necessary to process and select data. For these reasons, the previously written software needed to be redesigned to: 1) allow support for new data sources to be added with minimal new code, 2) for variation

in the algorithm to be supported per task, and 3) improve performance over the old algorithm where possible.

The CPOD accomplishes goals 1) and 2) by using a plugin architecture. The functionality of the CPOD is separated into three major tasks: creating a new searchable database, updating a database with new data, and querying the database for data using a space/time window. These main steps are implemented in the code as swappable plugins. For example, in Figure 1, that shows the activity diagram for the “Update” command, the “Get Time, Lats, Lons From File” node may have a plugin that can be used with NUCAPS data or another plugin that can be used with VIIRS data. Thus, a wide variety of file formats and variation in the algorithm can be supported with an array of short plugins. Goal 3) was accomplished by changing the way the database is written to disk. In the first version of the software, the entire set of desired data was re-written to disk using a searchable format. That turned out to create multiple issues as the database needed to be reprocessed every time the data format changed. The new code only writes meta-data to disk, massively reducing the amount of file IO needed to update and query a database. This CPOD has already been used to process data from several hurricane seasons and can be used with any NetCDF/HDF data that includes a timestamp variable. Support for various formats that do not meet those requirements can be added if needed.

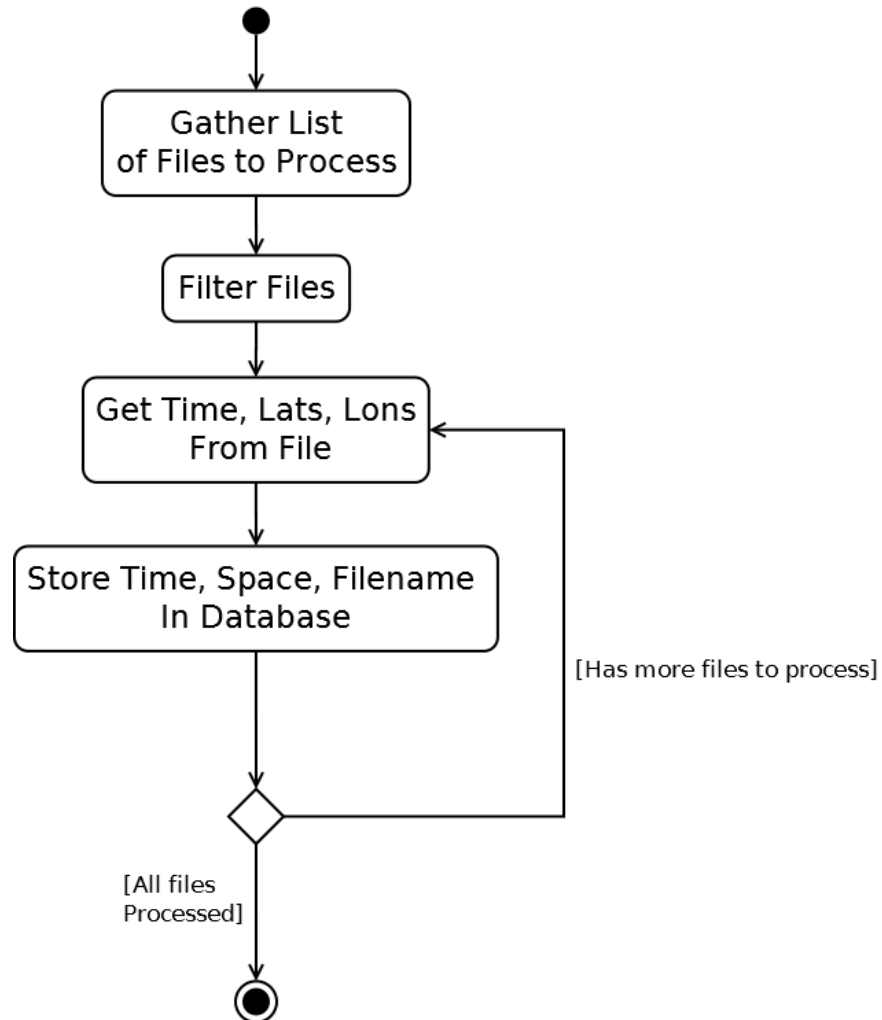

Figure 1. Activity diagram for the “Update” command. Each activity node is implemented in the code as a swappable plugin.

2--Continue developing database of ATMS-MIRS, NUCAPS, VIIRS, and ancillary data

The development of the database of ATMS-MIRS, NUCAPS, and VIIRS TC data has been continued. Specifically, the reprocessing of ATMS-MIRS and NUCAPS data using the new CIRA Polar-Orbiters Database (CPOD) software has begun. Pool database for the 2014-2015 NUCAPS data and 2014 ATMS-MIRS data has been created using the new software. In addition, testing of creating queries around TCs for both ATMS-MIRS and NUCAPS data has begun. Once the database and the queries are completed, they will be incorporated into data processing required for the moisture flux application.

3--VIIRS TC DNB imagery

The real-time code for displaying global VIIRS TC-centered real-time imagery has been updated. The updates consist of bug fixes and additional capabilities. The bug fixes include preventing duplicate images from being displayed online, filtering out incomplete data, and displaying data close to the dateline. The addition to the code includes an algorithm to ensure past data will be reprocessed if the processing has been interrupted (e.g. network issues or power outages). Also, a single version of the code capable of processing real-time data with low-latency for different VIIRS bands has been created. This enables a processing of low-latency data for all currently displayed VIIRS bands. The current average latency is approximately two hours for IR and visible images and 1.5 hours for DNB. The displayed bands include high-resolution IR (I05, 11.45 μm , 375 m resolution), high-resolution visible (IO1, 0.64 μm , 375 m resolution), and DNB (DNB, 0.7 μm , 750m resolution). Together, all the above improvements resulted in a much more stable code which should ensure that almost all available images are displayed online. Figure 2 shows an example of IR and DNB images for TC sh062016, Ula. The previous version of the code was unable to display these images.

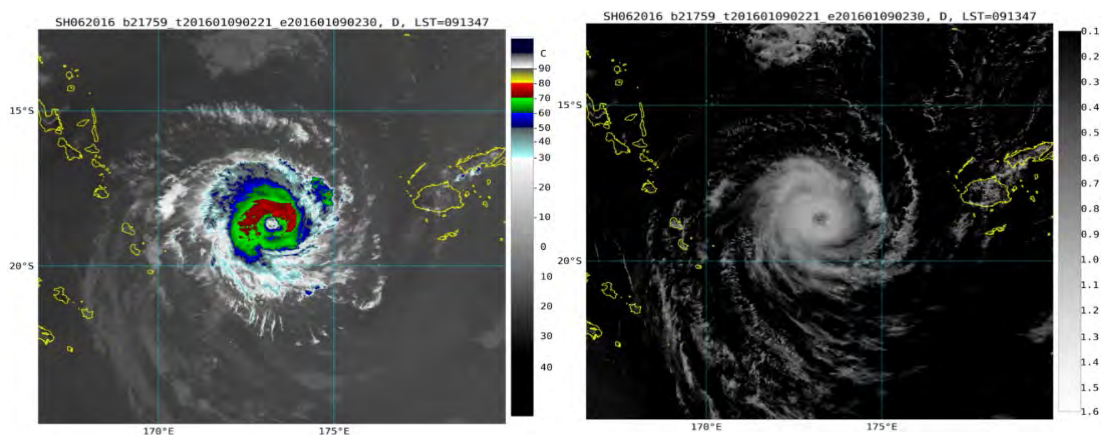

Figure 2. Examples of the high-resolution IR and high-resolution images close to the dateline. The previous version of the code was not able to display these images. Images are for the TS Ula, sh062016, on 2016 01/09.

In addition, work continued on looking at different categories of DNB images that are not well displayed, and investigating the possibility of improving the imagery in such cases. Figure 3 shows an example of low-light imagery (left) and its improved version. Work will continue on looking at different cases and developing an algorithm or combination of algorithms that provide the best overall performance.

In July, 2016 work began on delivering CIRA TC-centered VIIRS DNB and high-resolution IR imagery to NHC. Examples of VIIRS TC-centered imagery produced at CIRA were presented to NHC specialists and forecasters for testing and evaluation. Figure 4 shows an example of VIIRS TC imagery converted to NAWIPS format. NHC expressed interest in receiving the CIRA's TC-centered VIIRS imagery in real-

time on their N-AWIPS system. In response to that request, CIRA has developed the capability to convert TC-centered VIIRS imagery to N-AWIPS format and has been providing VIIRS high-resolution IR and DNB imagery to NHC in near-real time via LDM since the middle-August. NHC is currently putting that imagery on their operational N-AWIPS workstations. NHC provided feedback on VIIRS imagery, specifically indicating that it was useful during east Pacific storm Ivette and Atlantic storms Karl and Lisa. Figure 5 shows DNB and I05 images for the major Hurricane Gaston, as displayed on NHC's N-AWIPS system. NHC also expressed interest in receiving VIIRS TC-centered imagery from CIRA with low-latency, which will require CIRA to process data from JPSS Direct Broadcast sites.

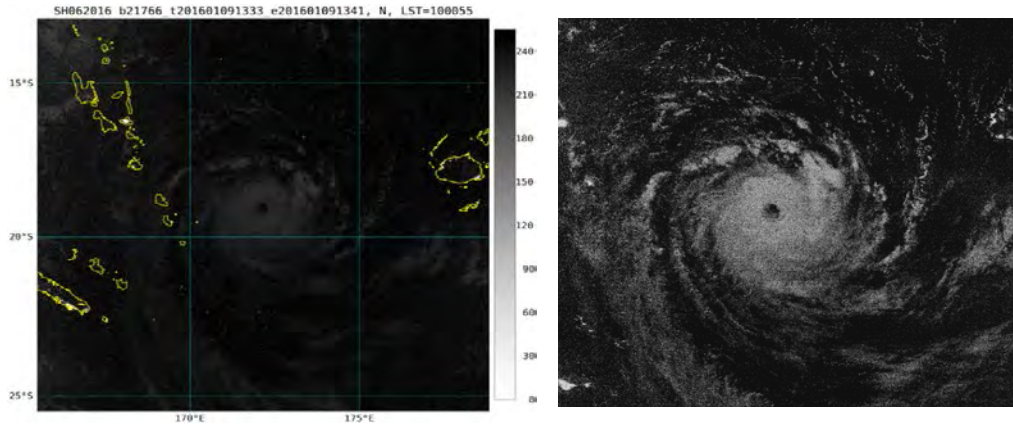

Figure 3. Low-light images as plotted by the current automated algorithm (Left) and manually adjusted for the best display (Right). Both of these images occurred very close to the new moon and had a minimal amount of light available. Images are for the tropical cyclone Ula, sh062016, on 2016 01/09.

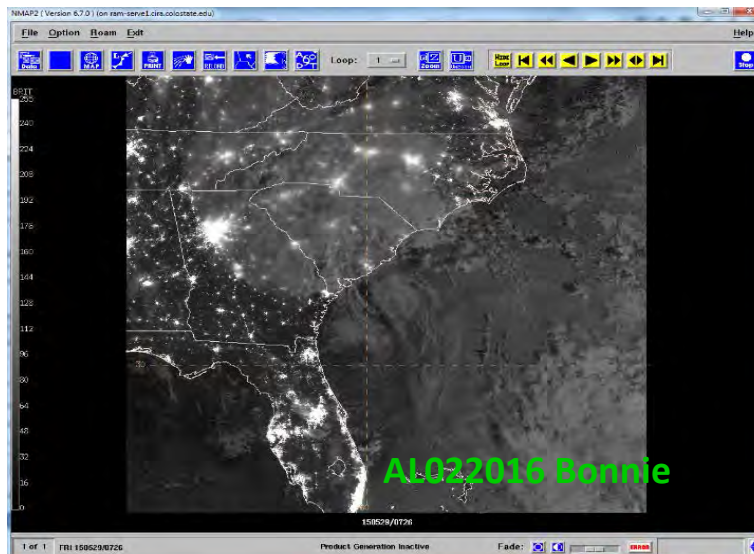

Figure 4. DNB imagery of Tropical Storm AL02 2016, Bonnie, displayed at NAWIPS system. The data from 05/29 at 07:29 UTC show the storm center completely obscured by the upper-level thin cirrus, but clearly visible on DNB. Figure contributed by Dan Lindsey.

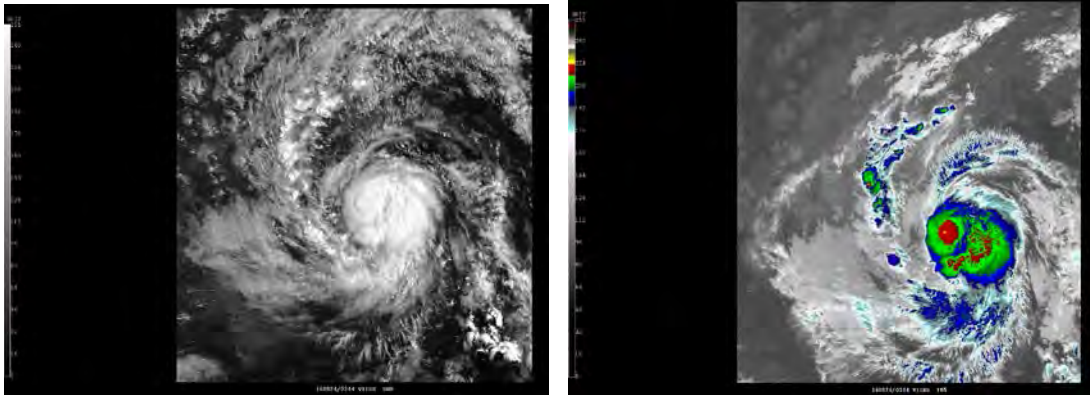

Figure 5. DNB (left) and I05 (right) imagery for major Hurricane Gaston, as displayed on NHC N-AWIPS system.

4-- Automated objective eye-detection algorithm

Several tasks have been completed for the automated eye-detection algorithm.

Additional wind and other ancillary data have been added to the eye-detection algorithm. A wide variety of available ancillary data such as the storm motion vector, the maximum TC wind speed, and the storm date and position were analyzed and the four predictors that best separated “eye” images from “no-eye” images were selected. The most significant among these predictors was the “maximum TC wind speed” which is included in ATCF best-track data. The “hybrid” version of the algorithm that uses both IT and ancillary shows a substantial performance improvement over the IR only algorithm and correctly classifies new images roughly 90% of the time (see Figure 6, “Num Correct” is the number of correctly classified cases) whereas the IR only version classified images correctly about 80% of the time. This performance places the accuracy very close to the underlying uncertainty of the problem. The data used for the development of the eye-detection algorithm were previously classified as “eye” or “no-eye” by hurricane specialists from NHC TAFB and NOAA/NESDIS SAB, and they agree on whether an image contains an eye roughly 95% of the time.

Further, both the IR-only and the hybrid IR and best track versions of eye-detection algorithm were modified to generate an estimated probability that an eye is present in an image rather than to perform a simple binary classification that only classified an image as a binary “eye-present” or “eye-absent”. This provides additional information to the users, and will also be more useful for use as input to the Rapid Intensification Index (RII). When the probability that an image contains the eye is above 50% the updated algorithms would classify the image as “eye-present”. The probabilities of the eye-detection algorithm had a Brier Skill Score (BSS) of about 0.6. Figure 7 shows the output of the quadratic discriminant analysis (QDA) and linear discriminant analysis (LDA) versions of the hybrid IR and best track algorithm run over the lifetime of Hurricane Katrina (al122005). It can be seen that both QDA (red line) and LDA (green line) probabilities of eye presence increase as the storm intensifies. The algorithm was less confident during storm intensification (cases 9 – 14 on Figure 7). Similar results were obtained for tropical storm Arlene (al012005) and hurricane Danielle (al062010). Additionally, while the algorithm produced an incorrect binary classification for case 7, the probabilities did see an increase for that case.

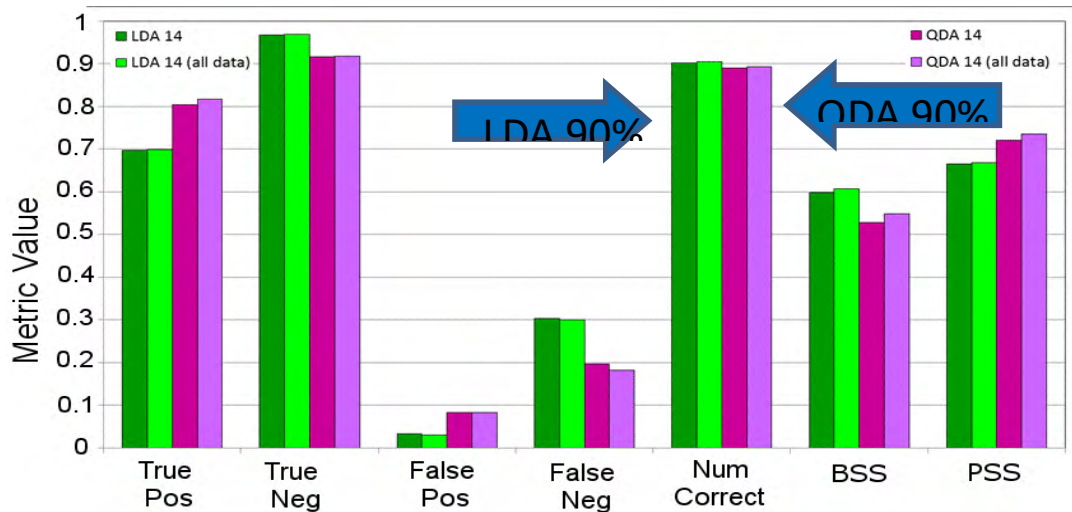

Figure 6. Eye-detection number of correct classifications has increased to about 90% after incorporating additional wind data into the algorithm.

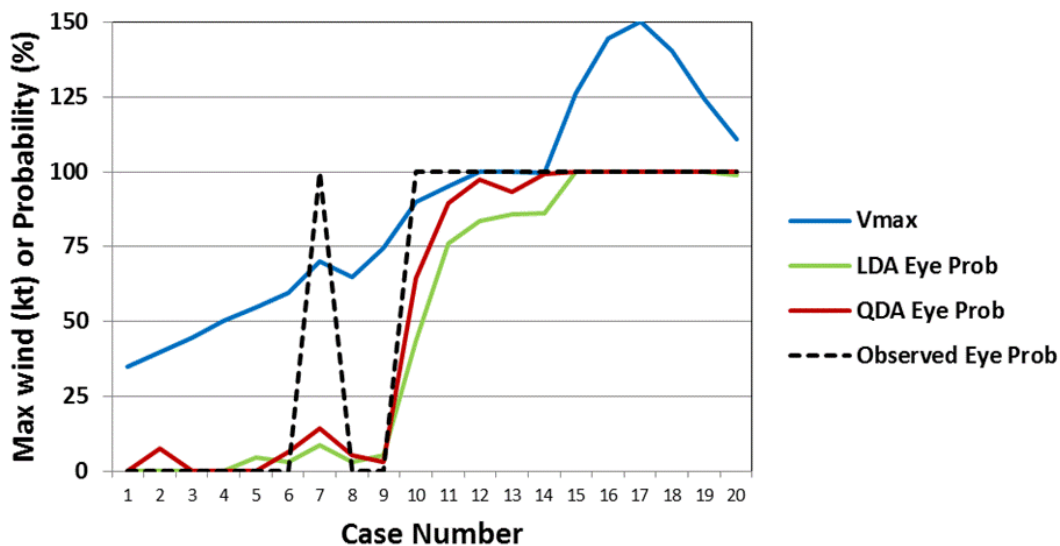

Figure 7. Algorithm probabilities/classifications vs truth for the lifetime of Hurricane Katrina, al122005.

The case number represents an IR image obtained at each synoptic time during the lifetime of Hurricane Katrina. Vmax (blue line) was obtained from the best track. The green and red lines are the estimated probability that an image contained an eye. The green line is provided by Linear Discriminant Analysis (LDA) and the red line is provided by Quadratic Discriminant Analysis (QDA). The black dashed line represents whether an eye was observed by a forecaster from TAFB while performing a Dvorak fix. LDA/QDA probabilities above 50% are classified as “eye-present” cases. LDA and QDA misclassified case 7 and LDA also misclassified case 10.

The algorithm has been further modified to use VIIRS IR data as input in addition to geostationary IR data. The additional information contained in high resolution VIIRS imagery may assist the algorithm in cases that are difficult to classify. The amount of currently available VIIRS IR data is not sufficient to fully retrain the algorithm. As a workaround, the algorithm was modified to use inverse squared distance interpolation to convert the VIIRS IR data to the 4km resolution grid the algorithm was trained on. Figure

8 shows a scatter diagram of the eye probabilities with VIIRS input versus that with GOES input for the 89 test cases from 2014-2015. The correlation coefficient between the two probability estimates was 0.995. Both the VIIRS and GOES versions algorithm had a MAE of 0.23. These results indicate that the GOES data can be replaced by the smoothed VIIRS data without changing the underlying algorithm. This is an encouraging result because it indicates that the GOES algorithm can be used as input to a correction step that uses additional features from full resolution VIIRS imagery. The correction algorithm will not rely on EOFs, so it can be developed from a much smaller sample. The correction algorithm will be part of the iterative procedure, as described below.

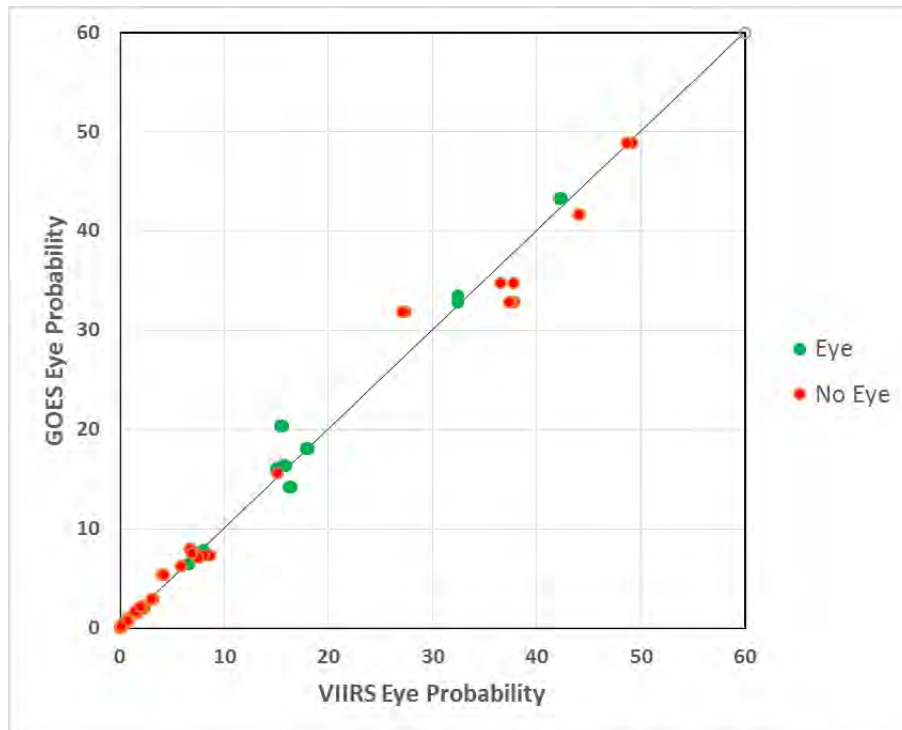

Figure 8. Scatter diagram of eye detection probabilities with VIIRS input versus that with GOES input for the 89 cases from 2014-2015. The cases with an eye (without an eye) as determined by the NHC Tropical Analysis and Forecast Branch (TAFB) are shown in green (red) points.

One of the very first steps performed by the eye-detection algorithm is selecting a small sub-set of data surrounding the tropical cyclone center. If the center location estimate is incorrect, this can lead to poor classification of the imagery. Currently, improving center location estimates is an open problem. Work has begun on a method to reduce the impact of poor center location estimates on algorithm performance. If the algorithm is run several times with each run using a small random offset from the provided center estimate, several probability estimates will be produced. These estimates can be averaged and may produce a more accurate estimate of whether the image contains an eye. Work will continue to develop this scheme and verify its impact on algorithm performance. Also, as described above, when sub-sampled, the VIIRS imagery produces results very similar to that from the GOES imagery. This indicates that when VIIRS imagery is available, the standard GOES-based algorithm can be used first, followed a by a second “correction” pass that refines the initial estimate using features from the full-resolution VIIRS imagery.

5--Moisture flux application using ATMS-MIRS and NUCAPS data

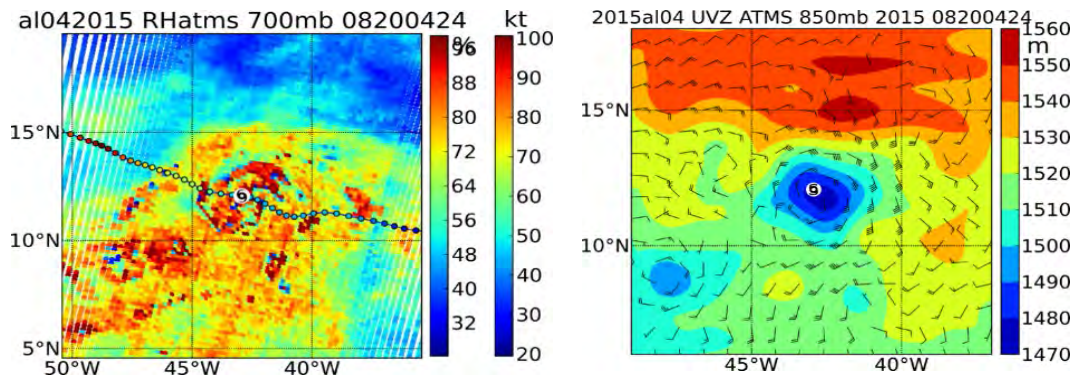

Figure 9. Left: ATMS-MIRS relative humidity at 700 hPa for hurricane Danny, al042015, on August 20, 2015, at 04:24UTC. The storm intensity at that time was 45 kt. Right: Matching balanced winds and geopotential height at 850 hPa derived from ATMS-MIRS using CIRA's operational algorithm.

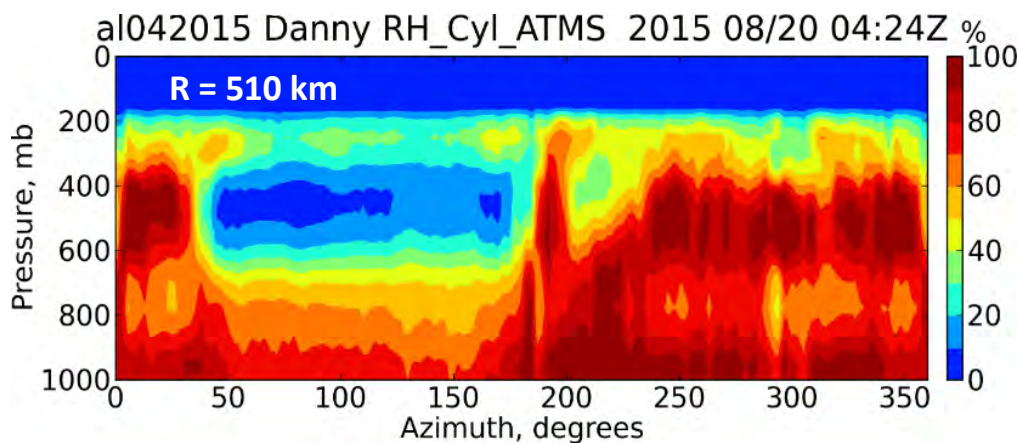

Figure 10. Relative humidity derived from ATMS-MIRS mixing ratio profiles at a cylinder around the center of hurricane Danny, al042015, on August 20, 2015, at 04:24UTC.

RH is shown approximately 2 degrees and 5 degrees longitude around the storm center, zero on the x-axis is north from the storm, and 90° is east from the storm center. These RH fields match RH at 700 hPa and winds shown in Figure 9.

Dry air intrusions are an important factor for TC intensity changes. The radial flux contribution to the time tendency of the total mass of water vapor contained within the volume $r = 0$ to R , $\lambda = 0^\circ$ to 360° , and pressure P_s to 100 hPa can be estimated as

$$MF(R) = \frac{R}{g} \int_{P_s}^{100 \text{ hPa}} \int_{0^\circ}^{360^\circ} q(R, \lambda, p) u(R, \lambda, p) d\lambda dp, \quad (1)$$

where R is the radius at which MF is evaluated; λ - azimuth; u - radial wind component; q - mixing ratio; p - pressure; P_s - surface pressure. The magnitude and direction of moisture flux at a given radius R from the TC center can be estimated from ATMS and/or NUCAPS, using relative humidity (RH) calculated from ATMS-MIRS and NUCAPS mixing ratio profiles, and GFS winds.

The code was developed to calculate and plot relative humidity on a cylinder at different distances from the storm center. Figure 9 shows an example of the different fields that will be used as input for the

moisture flux application. The example is for hurricane Danny from 2015 and has been used in January 2016 for the NHC PG presentation. As can be seen from Figure 10 that shows the RH around the storm, dry air is entering the storm environment from the east. While the environment remains mostly moist at 266 km from the storm center (Figure 10, upper), at 510 km (Figure 10, lower) there is a significant layer of dry air present at the middle levels (around 500 hPa). In addition, the software to calculate radial moisture flux using GFS winds and the code to estimate the integrated moisture flux convergence (MFC) using equation (1) has been developed and combined with the previously developed code to select matching ATMS and GFS data, and interpolate them to a cylindrical grid. As a next step, the MFC will be calculated for all cases available from 2012 to 2016 and the statistical relationship between Vmax and MFC at several distances from TC center will be evaluated and prepared to use for testing in the Rapid Intensification Index model.

6-- Evaluate NUCAPS data in TC environment

The evaluation of NUCAPS data by comparing them with dropsondes, ATMS-MIRS, and GFS temperature and moisture profiles has been completed. It was found that the NUCAPS temperature profiles tend to have a smaller bias and MAE compared to ATMS-MIRS profiles, especially away from TC center. NUCAPS moisture is also slightly better than ATMS-MIRS, except close to TC center, where NUCAPS has rather large errors. Overall, NUCAPS seems to provide data superior to ATMS, however, the number of available good NUCAPS soundings in the TC vicinity is usually much smaller compared to ATMS-MIRS, and might not be large enough to accurately sample the environment.

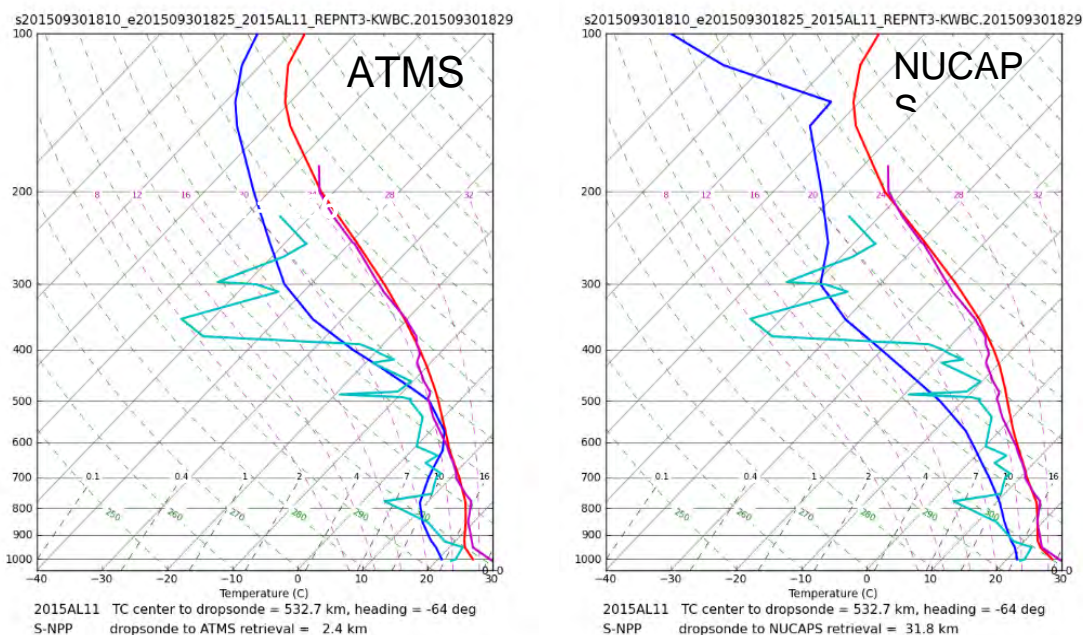

Figure 11. ATMS-MIRS (left) and NUCAPS (right) soundings collocated to dropsonde for al112015, major hurricane Joaquin, on September 30, 2015 at 18:25UTC. Red line: T (ATMS/NUCAPS), blue line: dew point Td (ATMS/NUCAPS); magenta line: T (dropsonde), cyan line: Td (dropsonde).

Figure 11 shows the collocation of a dropsonde with an ATMS-MIRS sounding (left) and NUCAPS sounding (right). The dropsonde is located 533 km away from the storm center. NUCAPS provides data for only 30 soundings across the swath. ATMS-MIRS has better horizontal resolution and provides 96 FOVs across the swath. However, both T, q from NUCAPS look more similar to the dropsonde than ATMS-MIRS, especially at the lower levels. For example, ATMS-MIRS tends to have a cold and dry bias at the surface. The cold and dry ATMS biases at the surface are clearly seen on the left plot. NUCAPS surface values of both T and Td are very similar to the dropsonde values. Both ATMS-MIRS and

NUCAPS T soundings look similar to the dropsonde T profile at the upper levels. The biggest difference between ATMS-MIRS and NUCAPS moisture is observed around the 550 hPa level. Moisture from that level down to about 850 hPa can be very important for TC intensity changes because that is where drying often occurs in association with the Saharan Air Layer and other areas of strong moisture gradients.

7—Development of “proxy visible” algorithm

Work continued on the development of the "proxy-visible" algorithm. Four IR channels that will be used for the development of the proxy visible algorithm were identified. These are VIIRS channels M13 (4.04 μm), M14 (8.55 μm), M15 (10.763 μm), and M16 (12.013 μm). New modules for reading and scaling M-band data have been developed, as well as the software to project and regrid data from the above four channels, to remove the bow-tie effect, and to combine developmental data for a single case into a single HDF5 file that was created for each of the 20 cases previously selected for the algorithm development. Figure 12 shows the TC-centered images for four M-band channels for the wp042015 case (on April 02 2015 at 16:40 UTC).

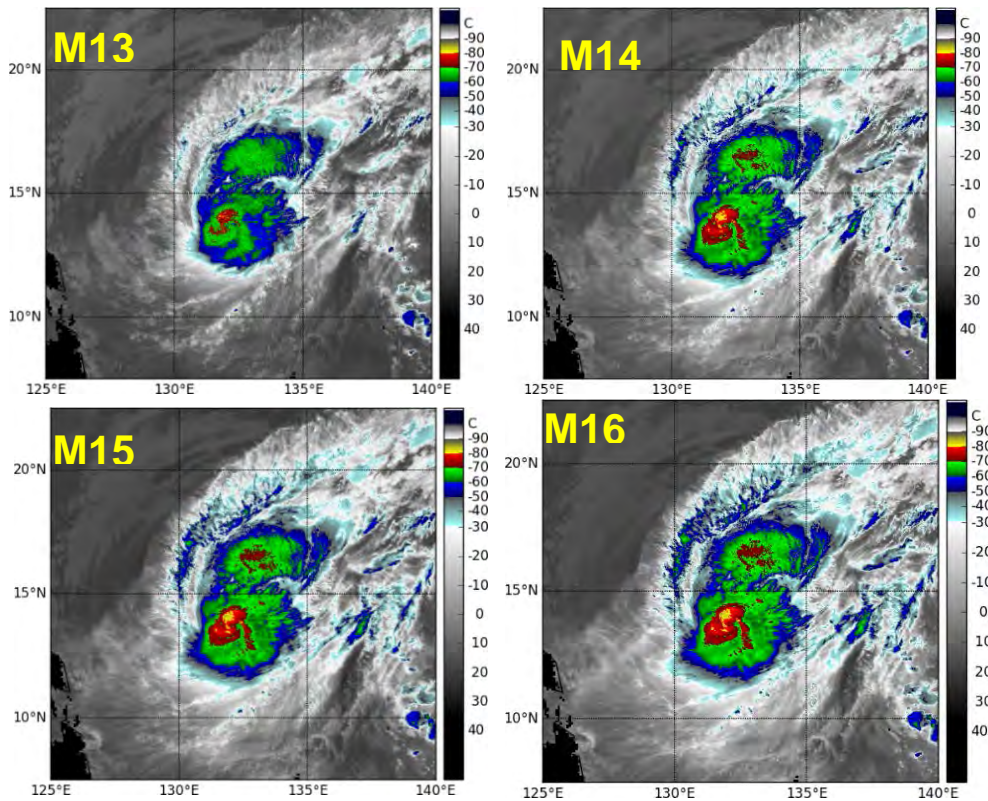

Figure 12. Four VIIRS M-bands (M13, M14, M15, and M16) for the Typhoon Maysak, wp042015 on April 02 2015 at 16:40 UTC.

8-- Estimate the utility of ATMS-MIRS/NUCAPS data for detecting warm core changes prior to RI

Work has begun on evaluating the utility of ATMS-MIRS data for detecting warm core changes prior to, and during RI. The database of all available ATMS-MIRS data and corresponding TC intensities for S-NPP passes within 800 km of a TC center has been created. A total of 1423 ATMS passes over TCs including 162 RI cases with intensity change of more than 25 kt have been identified. Several RI and non RI cases were selected from the database to look at the warm core changes. Figure 13 shows the vertical cross-section of azimuthally-averaged temperature for Hurricane Edouard and the corresponding intensity change for several times. The changes in the temperature field at the time of RI are clearly seen on these plots.

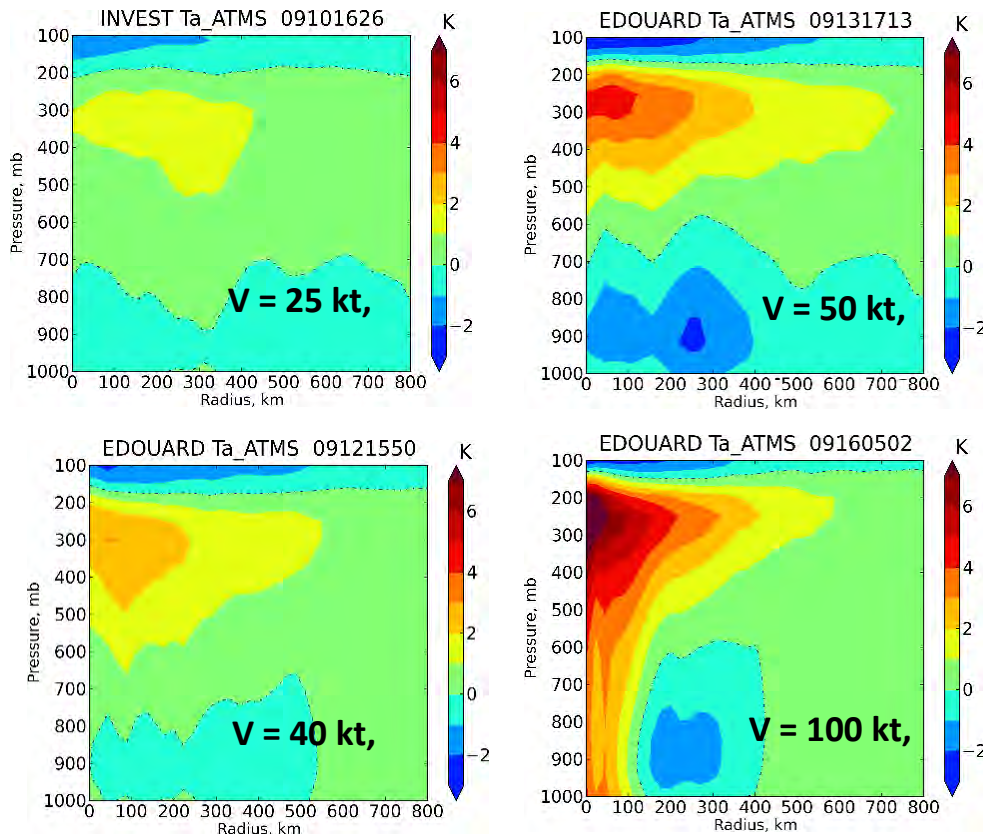

Figure 13. Azimuthally-averaged vertical temperature cross-section for Hurricane Edouard, a062014 for four different times, and the corresponding intensity change from the ATCF Best Track.

In addition, work begun on looking at the changes in the ATMS temperature fields to see if RI is associated with better vortex alignment. In order to see these changes, we need to look at vertical temperature cross-sections along- and cross-shear, rather than the azimuthally-averaged vertical profiles. In order to do that, the vertical shear values were obtained from the Statistical Hurricane Intensity Prediction Scheme (SHIPS) diagnostic files, available at http://rammb.cira.colostate.edu/research/tropical_cyclones/ships/developmental_data.asp. These files include the database of 850-200 hPa shear with the vortex removed and averaged from 0-500 km relative to 850 hPa vortex center (SHDC), as well as the heading of the above shear vector (SDDC). The cross-shear and along-shear changes were analyzed for the Edouard (a062014) case, and it was found that ATMS-MIRS data are capturing the warm core tilted downshear. Further testing that includes more cases and different ways of calculating anomalies is being conducted next quarter to determine the utility of ATMS data for detecting warm core changes during the RI.

9—Training

1--A training session on the use of VIIRS DNB imagery for TC forecasting has been included (by Dan Bikos) in the SHyMet Tropical course and published in the NOAA CLC.

Knaff J. and G. Chirokova, 2015: Use of VIIRS imagery for tropical cyclone forecasting. *VISIT Training Session is available online at*
http://rammb.cira.colostate.edu/training/visit/training_sessions/use_of_viirs_imagery_for_tropical_cyclone_forecasting. *SHyMet Tropical course is available online at*
http://rammb.cira.colostate.edu/training/shymet/tropical_topics.asp

2--Several applications developed as part of this project, including the moisture flux application, the eye-detection application, detecting worm core changes, and the VIIRS TC-centered DNB imagery have been presented at the NHC PG Review on February 17, 2017.

3—G. Chirokova presented a lecture covering several applications developed as part of this project at the JPSS Short Course at the 97th AMS Annual meeting

Publications: None

Presentations:

Chirokova, G., M. DeMaria, J. Dostalek, R. DeMaria, J. Knaff, K. Musgrave, and J. Beven: "Evaluation of the ATMS-MIRS and NUCAPS retrievals in the vicinity of Tropical Cyclones". 32nd AMS Conference on Hurricanes and Tropical Meteorology, 18 – 22 April 2016, San Juan, PR.

Chirokova G., J. Knaff, R. DeMaria, M. DeMaria, and J. Beven: "Use of the VIIRS Day-Night Band Imagery for Tropical Cyclone Analysis and Forecasting". 32nd AMS Conference on Hurricanes and Tropical Meteorology, 18 – 22 April 2016, San Juan, PR.

Chirokova G., M. DeMaria, J. Dostalek, R. DeMaria, J. Knaff, and J. Beven, 2016. ATMS-MIRS Retrievals in Tropical Cyclone Environments: Evaluation and Applications. StAR JPSS 2016 Annual Science Team Meeting, 8-12 August 2016, College Park, MD

Chirokova, G., A. Schumacher, and E. Berndt, 2017: JPSS Tropical Cyclone Products. Lecture at the JPSS Short Course at the AMS 97th Annual Meeting, 21 January 2017, Seattle, WA.

Chirokova, G., M. DeMaria, R.T. DeMaria, J. Knaff, J.F. Dostalek, and J.L. Beven, 2017: Use of JPSS ATMS, CrIS, and VIIRS data to improve tropical cyclone track and intensity forecasting. AMS 97th Annual Meeting, 21-26 January 2017, Seattle, WA.

Chirokova G., J. Knaff, D. Lindsey, R. DeMaria, M. DeMaria, J. Knaff, and J. Beven, 2016. Tropical Cyclone uses of VIIRS. StAR JPSS 2016 Annual Science Team Meeting, 8-12 August 2016, College Park, MD. Available at http://www.star.nesdis.noaa.gov/star/meeting_2016JPSSAnnual_agenda.php

DeMaria M., J. L. Beven, G. Chirokova, E. Dagg, R. DeMaria, J. Knaff and A. Schumacher, 2017: Current and Upcoming Proving Ground Demonstrations at NHC. February 17, 2017, NHC, Miami, Florida.

DeMaria R., J. Knaff, G. Chirokova, and J. Beven: "Automated Objective Tropical Cyclone Eye Detection". 32nd AMS Conference on Hurricanes and Tropical Meteorology, 18 – 22 April 2016, San Juan, PR.

Dostalek, J., G. Chirokova, J. Knaff, S. Longmore, R. DeMaria, A. Schumacher, and C. R. Sampson. "Recent and Future Updates to the Operational, Satellite-Based Tropical Cyclone Products Produced at the Cooperative Institute for Research in the Atmosphere". 32nd AMS Conference on Hurricanes and Tropical Meteorology, 18 – 22 April 2016, San Juan, PR.

Knaff J. A., T. Birner, G. Chirokova, L. Rivoire, and R. DeMaria: "Satellite Views of the Tropical Cyclone Lifecycle". 32nd AMS Conference on Hurricanes and Tropical Meteorology, 18 – 22 April 2016, San Juan, PR.

Seaman C., D. Lindsey, S. Miller, J. Knaff, G. Chirokova, J. Dostalek, A. Schumacher, K. Musgrave, L. Grasso, J. Forsythe, R. DeMaria, and D. Molenaar, 2016: CIRA/RAMMB Research Activities in Support of the OCONUS. 2016 GOES-R/JPSS OCONUS Satellite Proving Ground Technical Interchange Meeting, 27-30 June 2016, Honolulu, HI

PROJECT TITLE: CIRA Support to the JPSS Proving Ground and Risk Reduction Program: Cold Air Aloft Aviation Hazard: Detection Using Observations from the JPSS Satellites and Application to the Visualization of Gridded Soundings in AWIPS II

PRINCIPAL INVESTIGATOR: Jack Dostalek

RESEARCH TEAM: Rosemary Borger, Kevin Micke

NOAA TECHNICAL CONTACT: Satya Kalluri (NOAA/NESDIS) and Mitch Goldberg (NOAA/NESDIS/JPSS Program)

NOAA RESEARCH TEAM: Carrie Haisley (NOAA/NWS) and Gail Weaver (NOAA/NWS)

FISCAL YEAR FUNDING: \$25,000

PROJECT OBJECTIVES:

At high latitudes during the winter months, the air at altitudes used by passenger and cargo aircraft can reach temperatures cold enough (-65°C) such that the jet fuel used by the aircraft can begin to freeze. Currently, aviation forecasters rely on a combination of isolated aircraft reports, a sparse network of radiosondes, and global model fields for identifying and characterizing these cold air hazards. They have, however, expressed a need for additional data that can be used to fill in observational data gaps and/or confirm information that is seen in models. Direct-broadcast satellite soundings offer a potentially valuable source of observations that can greatly improve the information forecasters disseminate to pilots in real-time. Retrievals from the JPSS series of satellites, such as the NUCAPS algorithm which uses both the CrIS and ATMS instruments, offer the latest in retrieval capabilities. These retrievals may be combined with the additional coverage offered by the numerous satellites from which MIRS retrievals are available to effectively observe the areas of potentially dangerous cold air within jet aircraft flight tracks.

This project, a multi-agency effort with participants from SPoRT, CIRA, CIMSS, GINA, and the NWS, is ultimately tasked with providing satellite-derived cold air aloft visualization for display within AWIPS II. CIRA's primary contribution to this project, however, is to develop web-based tools for monitoring cold air aloft as a complement to the AWIPS II activities. Ideas can be more quickly implemented via web loops, and cold air aloft information can be received by users without AWIPS II. The work this reporting period was centered around three objectives: 1) Maintain and update the cold air aloft website as needed, 2) Incorporate data from additional retrieval algorithms, in particular the Dual Regression algorithm and the NUCAPS retrievals available from the S-NPP satellite, and 3) Along with the other project members, perform a testbed evaluation of the NUCAPS product.

PROJECT ACCOMPLISHMENTS:

Maintenance of Website:

In coordination with Carrie Haisley and Gail Weaver of the Anchorage, AK Center Weather Service Unit the domains covered by CIRA's cold air aloft loops were altered to be of most use for the Alaskan forecasters. There are four sets of two loops, each set consisting of images from a different data set. The four data sets are NUCAPS, ATMS-MIRS, AMSU-MIRS, and the GFS analyses. Figures 1 and 2 below demonstrate the two domains (Arctic Overview and Alaska) with the NUCAPS data.

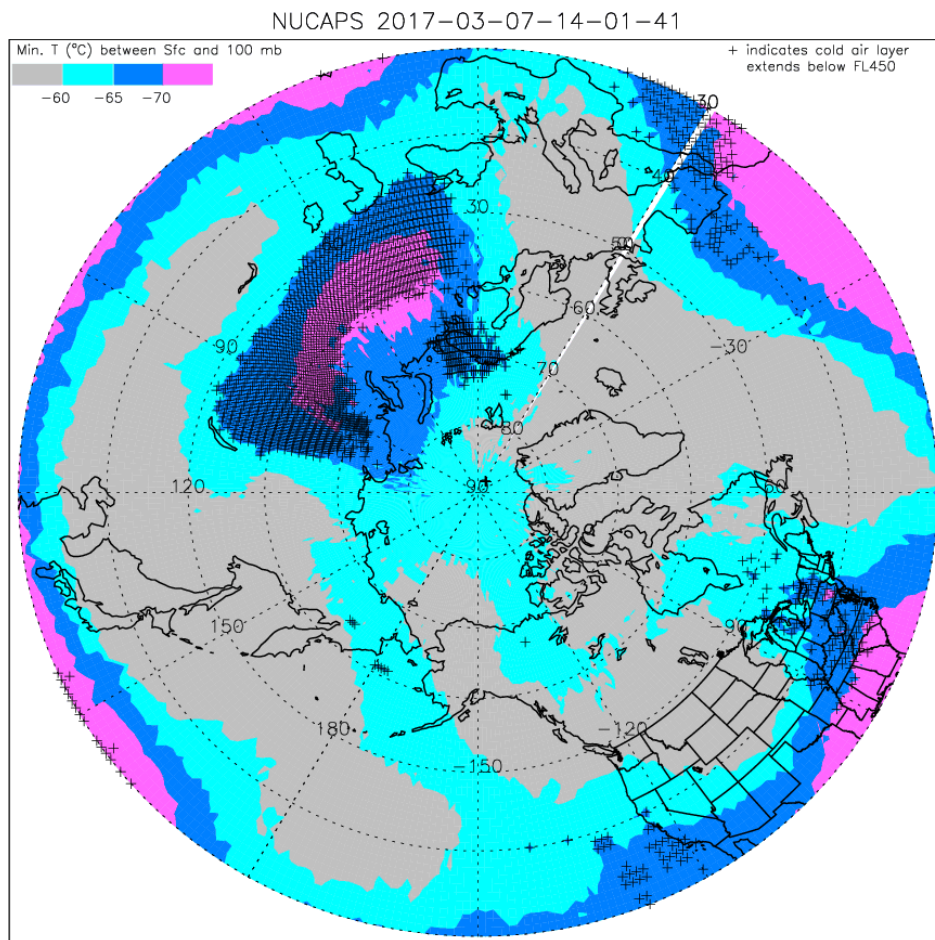

Figure 1. Arctic overview sector from 14:01:41 UTC on 7 March 2017 created from NUCAPS data. Colors represent coldest temperatures from the surface to 100 hPa. The '+' signs indicate where the cold air is found at or below Flight Level 450.

NUCAPS 2017-03-07-14-01-41

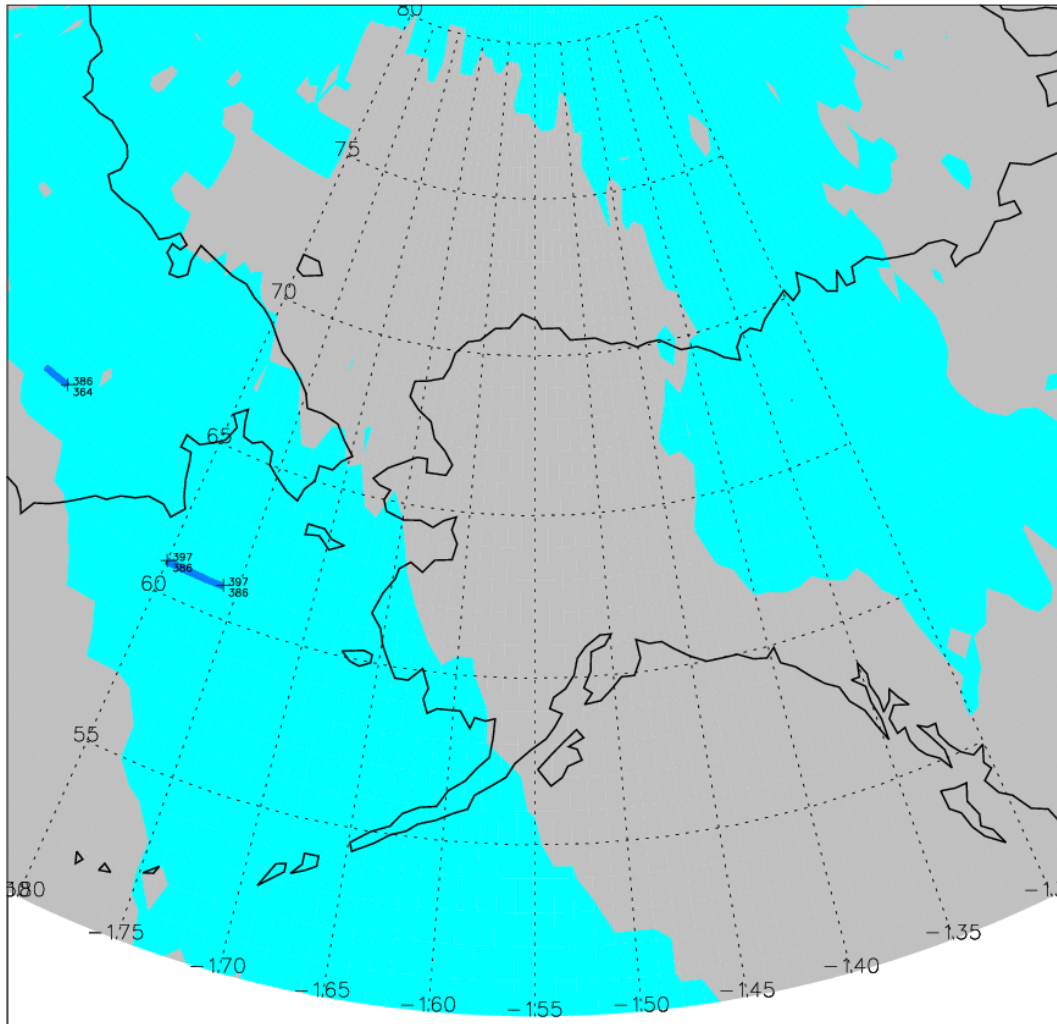

Figure 2. As in Figure 1, only for the Alaska sector. The numbers to the right of the '+' indicate the Flight Level bounds of temperatures below -65°C .

Incorporation of Different Retrieval Algorithms:

Initially, only the AMSU-MIRS retrievals were used to create the web page loops. Over the past year additional retrieval methods were processed for display on the cold air aloft web page. These include ATMS-MIRS retrievals, NUCAPS retrievals, and GFS analyses. At this time, it has not been determined whether or not to process retrievals from the Dual Regression algorithm.

NUCAPS Evaluation:

During the 2016-2017 winter season, a focused evaluation of the ability of the NUCAPS retrievals to capture cold air aloft events over Alaska was performed. Forecasters at the Anchorage, AK Center Weather Service Unit were asked to report on the usefulness of the AWIPS II and web displays of NUCAPS data in their decision making process when issuing cold air aloft Meteorological Impact Statements. Results of the evaluation will be used to implement changes in the products for the 2017-2018 season.

Publications: None

Presentations:

Dostalek, J., 2016: Using Polar-Orbiting Satellites to Monitor the Upper Atmosphere for Cold Air Pockets That Are Potentially Dangerous to Passenger Aircraft. Joint 21st Satellite Meteorology, Oceanography and Climatology Conference and 20th Conference on Air-Sea Interaction, Madison, WI, 15-19 August 2016.

Dostalek, J., 2016: Using Polar-Orbiting Satellites to Monitor the Upper Atmosphere for Cold Air Pockets That Are Potentially Dangerous to Passenger Aircraft. National Weather Association's 41st Annual Meeting held, Norfolk, VA, 10-15 September 2016.

PROJECT TITLE: CIRA Support to the JPSS Proving Ground and Risk Reduction Program: In Pursuit of the Shadows: VIIRS Day/Night Band Research Enabling Scientific Advances and Expanded Operational Awareness of the Nocturnal Environment

PRINCIPAL INVESTIGATOR: Steven Miller

RESEARCH TEAM: Curtis Seaman, Yoo-Jeong Noh, Louie Grasso, Scott Longmore, Cindy Combs, Natalie Tourville

NOAA TECHNICAL CONTACT: Satya Kalluri (NOAA/NESDIS)
and Mitch Goldberg (NOAA/NESDIS/JPSS Program)

NOAA RESEARCH TEAM: Dan Lindsey (NOAA/NESDIS/STAR/RAMMB)

FISCAL YEAR FUNDING: \$91,181

PROJECT OBJECTIVES:

The overarching goal of this project is to integrate 'low-light visible thinking' into the minds of the operational forecaster, providing familiarity with the new technology, and a new empowerment to forecasters as they contend with longstanding challenges of nocturnal environmental characterization. This research spans essential DNB tool development, novel user applications, instrument stewardship, and foundational research. Key components of this research are listed below:

1--Lunar Irradiance Modeling:

This proposal will continue the work to advance the model's phase-dependent albedo using lunar views, reducing biases. We will also verify and quality-control the model's performance as applied to the DNB radiances, and assist in its infusion to various NOAA nocturnal applications to expand the baseline suite of JPSS products.

2--Nocturnal Imagery Application Development:

We will continue to refine and explore new nocturnal applications involving the DNB, including: i) Dynamic Scaling Algorithm, ii) Disaster Monitoring, (anthropogenic light changes), iii) Cryospheric Applications (snow cover, sea ice), iv) Visibility Hazards (fog, fires/smoke, dust, ash), and v) Tropical Cyclones (exposed low-level circulation)

3--Sensor Performance Assessment & Preparation for JPSS-1 (J1):

This proposal will secure our participation in ongoing Cal/Val Team discussions, Technical Interchange Meetings, test/evaluate potential software solutions, and support studies concerning DNB data quality on J1 and beyond. These interactions will involve the broader community of Sensor Data Record

(SDR) Cal/Val and various industry partners involved in the ongoing performance assessment and waivers process.

4--Exploratory Studies:

We propose to expand the horizons of science by researching the information content present the DNB nightglow observations. This work will include the analysis and interpretation of gravity waves occurring globally as observed via specially scaled DNB nightglow imagery during the new-moon phase. We will also continue the search for widespread 'milky sea' marine bioluminescent events via strategic monitoring of historically active locations in Southwest Asia and Indonesia.

5--Training Opportunities:

From the rich pool of examples produced here we will formulate user training, leveraging established programs and tools such as VISIT, interactions with the Satellite Liaisons (in particular, the JPSS Satellite Liaison, Jorel Torres, the Alaska Region Liaison, Eric Stevens), Cooperative Institute managed web-based blogs, and other mechanisms such as subject matter expert consulting to the COMET program.

This project directly addresses NOAA's Weather Ready Nation objectives. The project also fits under the Satellite Algorithm Development, Training and Education theme of CIRA's current Cooperative Agreement with NOAA.

PROJECT ACCOMPLISHMENTS:

1--We are working on a journal paper summarizing the developments of the lunar irradiance model and its validation. We have been contacted by multiple researchers who have interest in using the refined model for their own research pursuits.

2--We have developed a merged "Day/Night Snow/Cloud Discriminator" that combines the previous daytime-only Snow/Cloud Discriminator with the recently developed nighttime version that utilizes the Day/Night Band. An example is shown in the figure below. This product is now available in near-real time on the RAMSDIS Online website. We are working with Eric Stevens (U. Alaska-Fairbanks/GINA) to determine the best way to distribute it to forecasters in Alaska, who have expressed high levels of interest in this product.

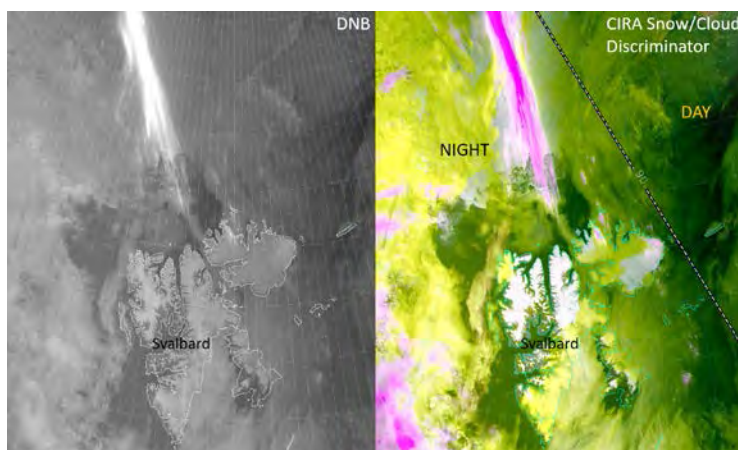

Figure 1. VIIRS Day/Night Band image (left) and Day/Night Snow/Cloud Discriminator (right) from 02:21 UTC 12 September 2016. The Snow/Cloud Discriminator uses the Day/Night Band along with 10 other VIIRS bands to discriminate snow and ice (white) from low clouds (yellow) and high clouds (magenta). The dashed line (right) represents the day/night terminator.

--DNB imagery is produced in near-real time on CIRA's RAMSDIS Online and TC Realtime webpages. CIRA-produced imagery is distributed by GINA and NASA SPoRT to NWS users in the Alaska Region, National Hurricane Center, Ocean Prediction Center and elsewhere.

3--We are working with the VIIRS Imagery Team and the JPSS Program to implement terrain-corrected geolocation for the Imagery Environmental Data Records (EDRs), including the Near Constant Contrast (NCC) EDR. We have demonstrated negative impacts on the NCC imagery caused by the lack of terrain correction in the EDRs. For example, fires detected in the NCC at night appear to move from one orbit to the next, purely due to a parallax-related artifact in high terrain, as the instrument line-of-sight is projected onto a smooth ellipsoid. This causes a displacement error in the apparent location of the fire. Correcting the geolocation for these terrain effects will benefit all EDR imagery on JPSS-1 and beyond.

4--We have documented numerous cases where ionospheric gravity waves have appeared Day/Night Band imagery as a result of airglow (Fig. 2). These waves are important for upper-atmosphere energy transport. Work has begun on the development of an automated gravity wave detection algorithm. We met a student of Prof. John Makela (Matthew Grawe; U. Illinois Urbana-Champaign) who is working on ionospheric waves. We may collaborate with him on wave detection techniques.

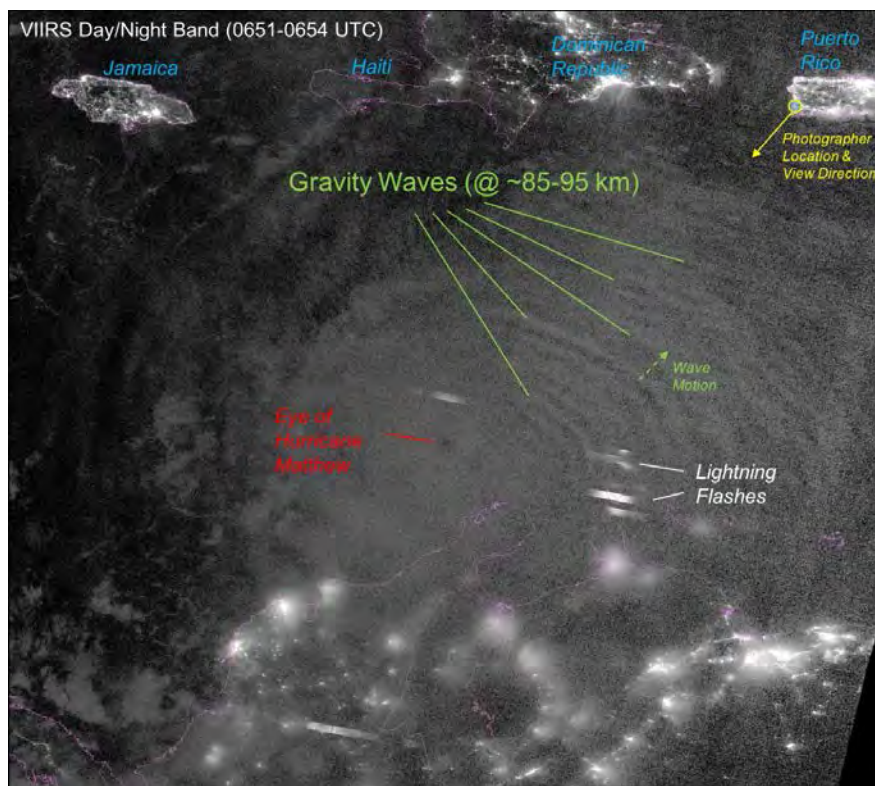

Figure 2. VIIRS DNB satellite image from 1 October 2016 at 0651 UTC shows gravity waves, lightning flashes and the eye of Hurricane Matthew. The arrow in the upper-right corner of the image shows the location of Frankie Lucena, a photographer who captured an image of these gravity waves as well as red sprites (stratospheric lightning) above the hurricane (Figure 3).

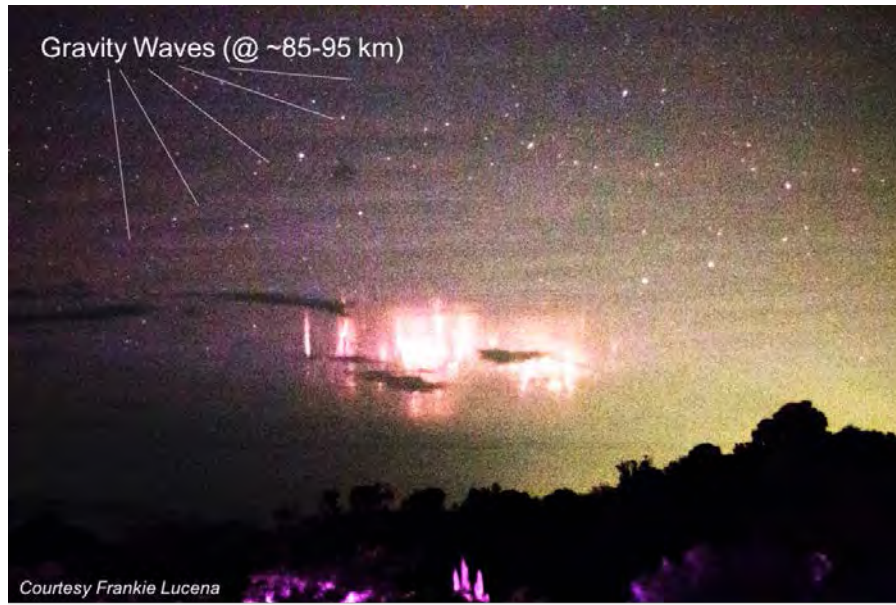

Figure 3. Photograph of mesospheric gravity waves at 85 to 95 km height and red sprite lightning flashes above thunderstorms which were created by Hurricane Matthew. (Photo by Frankie Lucena taken on 1 October 2016 at 0656 UTC).

--We continue to search for evidence of bioluminescence (milky seas) and have identified several cases with potential. More research is needed to verify the presence of bioluminescence in these cases.

5--We have done extensive training and outreach to users on the use of Day/Night Band (and NCC) imagery. A poster and oral presentation at the EUMETSAT Satellite Conference (26-30 September 2016) were very well received, with forecasters and researchers from KNMI, SMHI, EUMETSAT, Lithuania and South America all expressing an interest in our error function scaling algorithm for DNB imagery. This scaling algorithm has made it into operations in the NWS Alaska Region, thanks to a collaboration with CIMSS and GINA.

--JPSS Satellite Liaison Jorel Torres has become actively involved in the VISIT Training Blog, with 12 blog posts related to Day/Night Band applications. Curtis Seaman has also added 2 blog posts related to Day/Night Band applications to the VIIRS Imagery Team Blog. The CIRA Team frequently provides example DNB imagery and demonstrations of the use of DNB to WFO forecast offices. J. Torres and CIRA's WFO Liaison Ed Szoke participated in several WFO workshops and demonstrated DNB imagery to operational forecasters. J. Torres also participated in a "short course" at the AMS Annual Meeting (21-26 January 2017) where he trained users on DNB applications and use of NCC. Steve Miller has maintained close contact with the UCAR COMET program, which provides DNB training materials to a wide variety of users.

--Presentations on various applications of the DNB have been given at the AMS Annual Meeting, JPSS Annual Science Team Meeting, AMS Satellite Conference, National Weather Association Meeting, EUMETSAT Satellite Conference, and AGU Fall Meeting. William Straka (CIMSS) gave an invited seminar at EUMETSAT headquarters on DNB applications featuring numerous CIRA-produced examples. S. Miller also gave a presentation on the DNB to the Northern Colorado Astronomical Society. Informal presentations were also given to visitors from Chengdu University of Information Technology and Rick Anthes (UCAR President Emeritus).

--S. Miller taught nine class lectures for AT 652 (Remote Sensing) in the CSU Atmospheric Science department during the Fall 2016 semester. Several class lectures included DNB applications.

--This project continues outreach efforts with various media and social media outlets. CIRA produced DNB imagery is routinely featured on the @NOAASatellites Twitter and Facebook pages. S. Miller was also interviewed by The Huffington Post about airglow gravity waves. The cover of the November 2016 issue of the Bulletin of the American Meteorological Society featured a DNB image produced by S. Miller (Fig. 4).



Figure 4. The cover image of the November 2016 issue of BAMS produced by S. Miller.

Publications:

Albrecht, R., S. Goodman, D. Buechler, R. Blakeslee, and H. Christian, 2016: Where are the lightning hotspots on Earth? *Bull. Amer. Meteor. Soc.*, 97(11). doi:10.1175/BAMS-D-14-00193.1, BAMS Cover Image by Steve Miller.

Hillger, D. W., T. Kopp, C. J. Seaman, S. D. Miller, D. T. Lindsey, E. Stevens, J. Solbrig, W. Straka III, M. Kreller, A. Kuciauskas, and A. Terborg, 2016: User Validation of VIIRS Satellite Imagery. *Remote Sensing*, 8(11); doi:10.3390/rs8010011

Lai, C., J. Yue; J. Xu; W. Straka III; S. D. Miller; X. Liu, 2017: Suomi NPP VIIRS/DNB imagery of nightglow gravity waves from various sources over China. *Advances in Space Research*, in press. Manuscript Number: ASR-D-16-00683R1; Section: EM -Earth Magnetosphere/Upper Atmosphere.

Mills, S. and S. Miller, 2016: VIIRS Day/Night Band—Correcting striping and nonuniformity over a very large dynamic range. *J. Imaging* 2016, 2(1), 9; doi:10.3390/jimaging2010009

Presentations:

Chirokova, G., J. Knaff, D. Lindsey, R. DeMaria, M. DeMaria and J. Bevin, 2016: Tropical Cyclone Uses of VIIRS. STAR JPSS Annual Science Team Meeting, College Park, MD, 8-12 August 2016.

Miller, S.D., 2016: Satellite Research and Application Development at CIRA. NOAA/NESDIS CoRP Science Symposium, CIRA Science Project Overview. CIRA Executive Board Meeting, Fort Collins, CO, May 2016.

Miller, S., 2016: "Advances in Day/Night Band Science and Applications: Making Good on Promises of the Moon." 21st AMS Satellite Meteorology, Oceanography, and Climatology Conference, Madison, WI, 15-19 August 2016. Invited keynote presentation.

Miller, S. D., 2016: Day-Night Band. Science presentation for visitors of Chengdu University of Information Technology. Meeting held at CSU, Lory Student Center, Fort Collins, CO, July 2016.

Miller, S., C. Seaman, C. Combs, J. Solbrig, W. Straka III, A. Walther, Y.J. Noh, and A. Heidinger, 2016: "Status and Prospects for Low-Light Visible Sensing from the VIIRS Day/Night Band on Suomi NPP and JPSS-1." 2016 AGU Fall Meeting, San Francisco, CA, 12-15 December 2016. Oral presentation.

Miller, S. D., 2016: "Taking Back the Night with the VIIRS Day/Night Band." 2016 AGU Fall Meeting, San Francisco, CA, 12-15 December 2016. Invited oral presentation at NOAA Exhibit Booth.

Seaman, C., S. Miller, J. Torres, D. Lindsey, and D. Hillger: "VIIRS Imagery Applications at CIRA." 3rd Annual STAR/JPSS Science Team Meeting, College Park, MD, 8-12 August 2016. Oral presentation.

Seaman, C. J., D. T. Lindsey, S. D. Miller, J. A. Knaff, G. Chirokova, J. F. Dostalek, A. B. Schumacher, K. M. Musgrave, L. D. Grasso, J. Forsythe, R. DeMaria, D. A. Molenaar, 2016: CIRA/RAMMB Research Activities in Support of the OCONUS. OCONUS Technical Interchange Meeting, Honolulu, HI, June 2016.

Seaman, C. J., S. D. Miller and W. Straka III, Illuminating the Capabilities of the VIIRS Day/Night Band in the High Latitudes. 2016 EUMETSAT Meteorological Satellite Conference, Darmstadt. Germany, 26-30 September 2016. Oral presentation.

Seaman, C. J. and S. D. Miller: A Dynamic Scaling Algorithm for the Optimized Display of VIIRS Day/Night Band Imagery. 2016 EUMETSAT Meteorological Satellite Conference, Darmstadt. Germany, 26-30 September 2016. Poster presentation.

Seaman, C. J., S. D. Miller, D. T. Lindsey and D. W. Hillger: "JPSS and GOES-R Multispectral Imagery Applications and Product Development at CIRA." 97th AMS Annual Meeting, Seattle, WA, 22-26 January 2017. Poster presentation.

Seaman, C. J., W. Straka III, S. D. Miller, D. T. Lindsey and J. Torres: "Night Vision: Illuminating the Capabilities of the VIIRS Day/Night Band." 97th AMS Annual Meeting, Seattle, WA, 22-26 January 2017. Invited oral presentation at NOAA Exhibit Booth.

Straka, W., S. D. Miller, C. J. Seaman, D. T. Lindsey and J. Torres: "Usage of the VIIRS Day/Night Band as an Operational Tool." 97th AMS Annual Meeting, Seattle, WA, 22-26 January 2017. Oral presentation.

Straka, W., S. Miller and C. Seaman: "Overview of the Day and Night Band of VIIRS on Suomi-NPP with specific examples." Visiting Scientist Seminar, EUMETSAT, Darmstadt, Germany, 22 September 2016. Invited oral presentation.

Torres, J. B. Connell, and S. Miller, 2016: "JPSS Imagery and Products in AWIPS-II for NWS Forecasters." 21st AMS Satellite Meteorology, Oceanography, and Climatology Conference, Madison, WI, 15-19 August 2016. Poster Presentation.

Torres, J., B. Connell, and S. Miller: "JPSS Imagery and Products Available in AWIPS-II for NWS Forecasters." 41st Annual National Weather Association Meeting, Norfolk, VA, 10-15 September 2016. Oral Presentation.

Torres, J., B. H. Connell and S. D. Miller: "Utility of JPSS Products for NWS forecasters." 97th AMS Annual Meeting, Seattle, WA, 22-26 January 2017. Oral presentation.

PROJECT TITLE: CIRA Support to the JPSS Proving Ground and Risk Reduction Program: Improving NUCAPS Soundings for CONUS Severe Weather Applications via Data Fusion

PRINCIPAL INVESTIGATOR: Jack Dostalek

RESEARCH TEAM: John Haynes, Renate Brummer, Rosemary Borger, Kevin Micke, Natalie Tourville, Dave Watson

NOAA TECHNICAL CONTACT: Satya Kalluri (NOAA/NESDIS) and Mitch Goldberg (NOAA/NESDIS/JPSS Program)

NOAA RESEARCH TEAM: Dan Lindsey (NOAA/NESDIS/STAR/RAMMB) and Daniel Nietfeld (NOAA/OAR/ESRL)

FISCAL YEAR FUNDING: \$100,000

PROJECT OBJECTIVES:

Currently, the only observational platform having adequate vertical resolution of temperature and moisture for severe thunderstorm applications is the radiosonde. The vertical resolution is sufficient to detect sharp low-level temperature inversions and vertical gradients in moisture common during severe weather events. However, the major limitation of radiosonde data is inadequate temporal and spatial resolution. Balloons are launched only at 00 and 12 UTC (and occasionally at 18 UTC), and the launch sites are 300-500 km apart in the central U.S.

As part of the JPSS mission, under the direction of Chris Barnet, Science and Technology Corporation developed the NOAA Unique CrIS/ATMS Processing System, or NUCAPS. This algorithm uses data from the Cross Track Infrared Sounder (CrIS) in clear sky conditions and from the Advanced Technology Microwave Sounder (ATMS) in cloudy regions to retrieve global vertical profiles of atmospheric temperature and water vapor. These instruments are aboard the S-NPP satellite that was launched in November 2011, and are planned to be a part of the forthcoming JPSS satellites.

Given the requirement for NUCAPS to be available globally, it is a satellite-only retrieval and does not incorporate ancillary information other than surface pressure from the GFS model. The retrieved soundings are relatively smooth in the vertical and are unable to resolve sharp vertical gradients that are often found at the top of the boundary layers in a summertime severe weather environment.

NWP output continues to improve every year, especially with the advent of high resolution (e.g., <4 km grid spacing), convection-resolving models. But the models still struggle with important details such as surface to 850 mb moisture advection in the central plains of the CONUS. Surface analyses of temperature and water vapor are now available hourly at high resolution (2.5 km), from the Real-Time Mesoscale Analysis (RTMA). Strategically combining portions of the NWP output and RTMA data with the NUCAPS soundings will undoubtedly result in improved characterizations of the vertical profile of temperature and moisture than the NUCAPS soundings alone.

Work in 2016 focused on five objectives: 1) Launch radiosondes from northeast Colorado, timed with the S-NPP overpass, on days for which convection was likely, 2) Calculate error statistics of the NUCAPS data with respect to collocated radiosondes, 3) For the radiosonde data obtained in 1) collect corresponding NUCAPS, NWP, and RTMA data, 4) Begin creating the algorithm which modifies the NUCAPS soundings to generate a more accurate depiction of the pre-convective environment, and 5) Work on displaying the modified NUCAPS profiles in AWIPS II.

PROJECT ACCOMPLISHMENTS:

Northeast Colorado Radiosonde Launches:

In addition to the radiosondes collected from the NWS and SGP launches, 20 radiosondes were purchased for release by the project members. This additional dataset sampled the pre-convective atmosphere of the high plains environment of northeastern Colorado, which is in general different from the pre-convective environment of the central and southern plains, and the eastern United States. The opportunity was also taken to launch a few balloons when thunderstorms were not anticipated, to see how well the NUCAPS distinguishes between the two regimes. The launches were timed to coincide with the pass of the S-NPP satellite, with a typical launch time for the balloons of about one-half hour before the overpass.

Error Statistics:

Using a homogeneous sample from years 2014, 2015, and 2016, the performance of the NUCAPS retrievals and RAP profiles were compared with collocated radiosondes (within 50 km and 1 hour) for both temperature and dewpoint temperature. The bias and rmse as a function of pressure for the NUCAPS and RAP are shown in Figures 1 and 2. Looking at the temperature rmse, the NUCAPS retrievals are below 2 K from 100 mb to just above 2 K near the surface. The bias alternates between positive and negative, but is generally within 1 K. The RAP rmse is below 2 K and under 1 K for most of the middle atmosphere. The bias is around 1 K near the surface, and well below 1 K above the surface. Both the NUCAPS and the RAP show a poorer performance in measuring the vertical profile of the dewpoint temperature. For the NUCAPS, the rmse is generally between 2 and 6 K, with values above 7 K in the middle atmosphere. The struggle of NUCAPS in this region is due to the common existence of a sharp drop-off in moisture that is often seen between the low- and middle-levels. The coarse vertical resolution inherent in satellite retrievals makes it very difficult to capture such features. Biases for the NUCAPS dewpoint temperature are generally less than 4 K, with higher values at the drop-off in moisture just mentioned and near the tropopause. The RAP analyses also had difficulty in measuring the vertical distribution of water vapor. Although lower near the surface, the rmse was at least 5 K at all levels. Below 300 mb, the biases were less than 3 K, but were greater than 4 K at some pressures above this level. It appears that the RAP model also has trouble with the rapid decrease in moisture between the lower- and middle-levels.

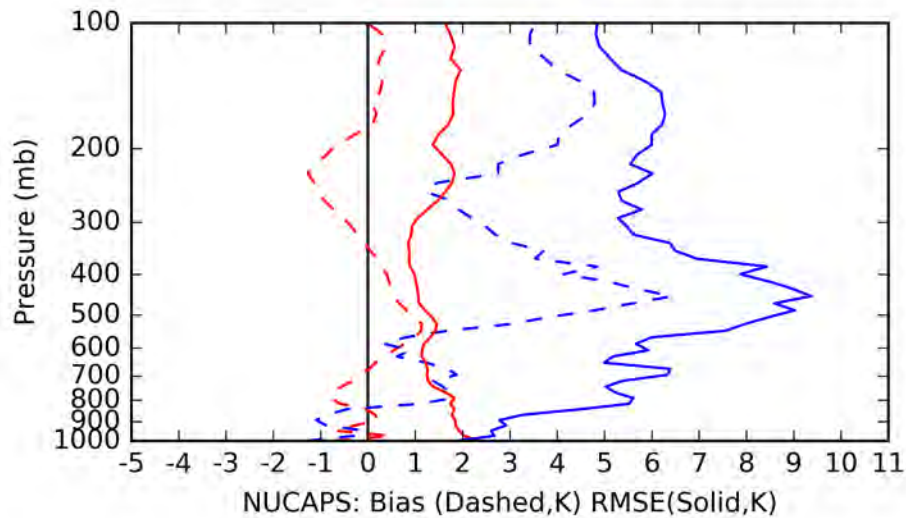

Figure 1. Bias and rmse between NUCAPS and collocated radiosonde as a function of pressure. Red lines are for temperature and blue lines are for dewpoint temperature.

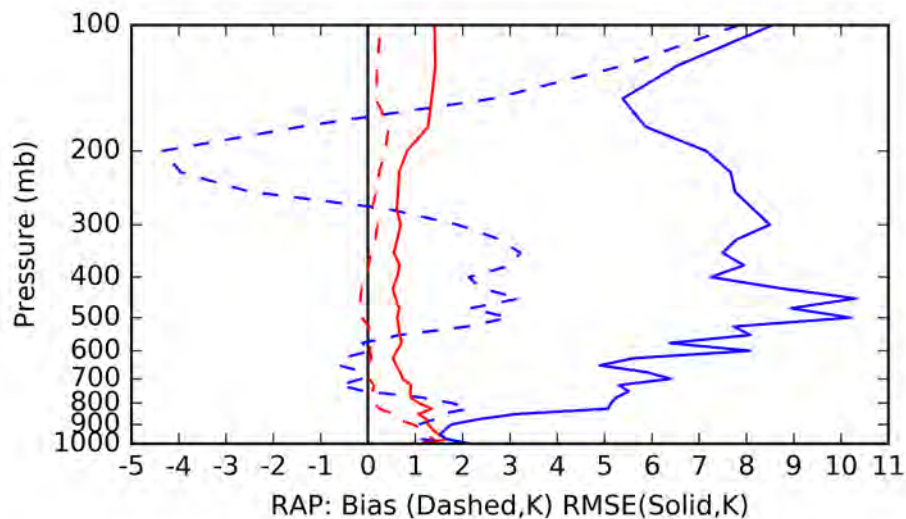

Figure 2. Bias and rmse between RAP and collocated radiosonde as a function of pressure. Red lines are for temperature and blue lines are for dewpoint temperature.

The figures demonstrate the greater accuracy of the RAP model over the NUCAPS retrievals. However, the RAP data used in these computations are the analyses, which likely assimilate some of the radiosonde data.

Ancillary Data Collection:

CIRA maintains an ongoing, real-time collection and archive capability for NUCAPS retrievals. Some case specific data from the RAP model and the RTMA have also been collected. For real-time application, both the RAP and the RTMA are available via NOAAPORT.

Algorithm to Modify NUCAPS Retrievals:

NUCAPS retrievals typically perform well in capturing the general shape of the temperature and moisture profile of the atmosphere, as seen in the example below. The red and blue lines in Figures 3 and 4 are the temperature and dewpoint temperature profiles, respectively, as measured by a radiosonde launched from Fort Collins, CO on 16 June 2016. The overlaid black lines are the temperature and dewpoint temperature retrievals from the NUCAPS algorithm. NUCAPS struggled, however, at the lowest levels – a characteristic not unusual in satellite retrievals.

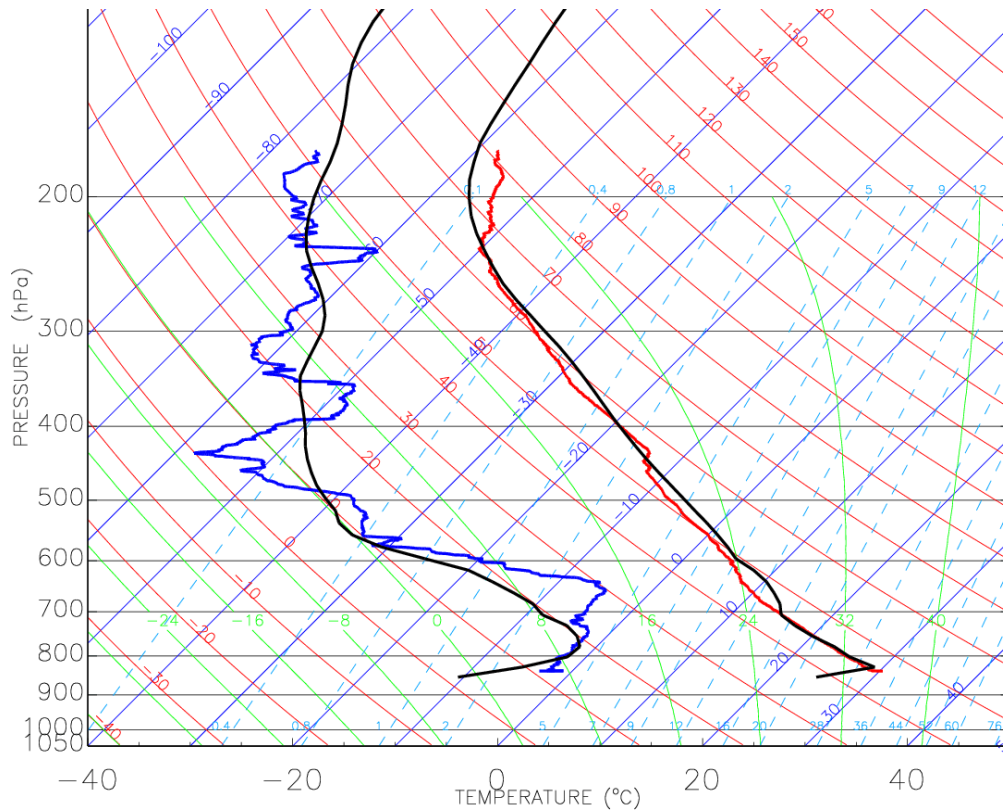

Figure 3. Vertical profile of temperature (red) and dewpoint temperature (blue) as measured by radiosonde. Black lines are the temperature and dewpoint temperature from a collocated NUCAPS retrieval. The NUCAPS retrieval captures the broad features of the temperature and moisture, but misses some of the fine details, and struggles near the surface.

In an attempt to correct these errors, a simple mixed layer algorithm was applied:

$$z_{i+1} = \left[z_i^2 + \frac{2}{\gamma} C_H |V| (\theta_{Skin} - \theta_{Air}) \Delta t \right]^{\frac{1}{2}}$$

Where

z : height of mixed layer

θ_{Skin} : Potential temperature of surface skin (GOES West sounder 11/12 μm)

θ_{Air} : Potential temperature of surface air (Surface observations)

$|V|$: Wind speed (Surface observations)

γ : Lapse rate of free atmosphere (12 UTC Denver Radiosonde)

C_H : Exchange coefficient

The mixed layer height was determined by applying the above equation from sunrise to 1900 UTC (just before the S-NPP overpass). Blending the mixed-layer temperature and moisture (using potential temperature and water vapor mixing ratio) with nearby surface observations results in the corrected profile shown below.

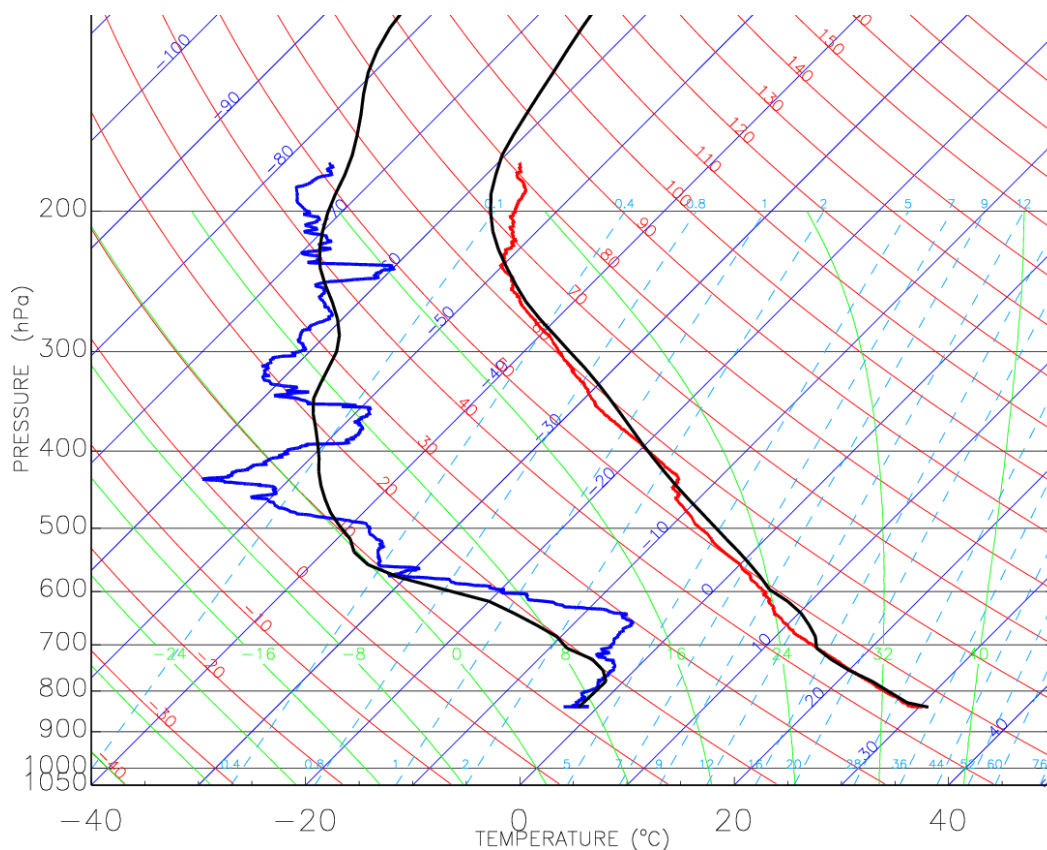

Figure 4. Same as above figure, but with the near-surface NUCAPS retrievals modified using a simple mixed-layer algorithm and surface observations.

For this case the simple algorithm worked quite well and as long as the assumption of a well-mixed boundary layer holds, it should be broadly applicable.

Modified NUCAPS Soundings in AWIPS II:

Work on making available the modified NUCAPS soundings in AWIPS II is well underway. Some difficulty has been encountered inside AWIPS II in relation to the system being able to distinguish the original NUCAPS retrievals from the modified retrievals. This issue is currently under investigation.

Publications: None

Presentations:

Dostalek, J., 2016: Using NUCAPS Retrievals to Diagnose Pre-Convective Environments over the United States. Joint 21st Satellite Meteorology, Oceanography and Climatology Conference and 20th Conference on Air-Sea Interaction, Madison, WI, 15-19 August 2016.

PROJECT TITLE: CIRA Support to the JPSS Proving Ground and Risk Reduction Program: JPSS Satellite Training for NOAA Users

PRINCIPAL INVESTIGATORS: Bernadette Connell and Steve Miller

RESEARCH TEAM: Jorel Torres, Ed Szoke, E. Dagg

TECHNICAL CONTACT: Satya Kalluri (NOAA/NESDIS) and Candice Jongsma (NOAA/OAR)

NOAA RESEARCH TEAM: Brian Motta and Anthony Mostek NOAA/ NWS/OCLO/ Forecast Decision Training Division, Leroy Spayd (NWS/OCLO)

FISCAL YEAR FUNDING: \$60,000

PROJECT OBJECTIVES:

This project supports a Satellite Liaison and research staff at the Cooperative Institute for Research in the Atmosphere (CIRA) as a critical link between the Joint Polar Satellite System (JPSS) program and National Oceanic Atmospheric Administration (NOAA) operational end users primarily at National Weather Service (NWS) Offices and National Centers. The Satellite Liaison is devoted to connecting satellite algorithm developers, trainers, and forecasters, enhancing multi-path communication, ensuring that operational needs are not lost in translation, while also steering and focusing the research and training directions to best serve operational needs.

The Liaison provides training for operational NWS forecast staff about multiple initiatives including NOAA-Unique Products, Day-Night Band, Visible Infrared Imaging Radiometer Suite (VIIRS) Imagery, Advanced Technology Microwave Sounder (ATMS), Cross-track Infrared Sounder (CrIS), NOAA Unique CrIS ATMS Products (NUCAPS), and Numerical Weather Prediction (NWP) data assimilation. This includes current JPSS Program initiatives such as Smoke and Fire, Hydrology and Flooding, Severe Convective Weather, Critical Weather Applications, and targeted specific NWS forecast and warning operations. The projects are coordinated with the NWS Office of the Chief Learning Officer (OCLO) in particular the Forecast Decision Training Division (FDTD).

Specific Objectives:

- 1-- Participate in JPSS Initiative teleconferences, take inventory of user needs and developer capabilities; map connections between the two.
- 2-- Interact and collaborate with training partners: the NWS OCLO, the Virtual Institute for Satellite Integrated Training (VISIT) and the Satellite Hydrology and Meteorology (SHyMet) training programs, the Short-term Prediction Research and Transition Center (SPoRT), COMET, and Satellite liaisons.
- 3-- Review draft JPSS Formal Training Program (Draft provided by Bill Ward and Jordan Gerth, January 2016), map existing training and training needs; prepare JPSS training tracking spreadsheet.
- 4-- Prepare training materials based on interactions with users, developers, and understanding of training requirements.
- 5-- Participate in Domestic Science Conferences (NWA/AGU/AMS) and travel locally to Boulder and Cheyenne WFOs.

PROJECT ACCOMPLISHMENTS:

- 1--Participate in JPSS Initiative teleconferences, take inventory of user needs and developer capabilities; map connections between the two.

The satellite liaison, J. Torres, participated in monthly JPSS Initiative teleconferences: River and Ice Flooding, Fire and Smoke, NUCAPS, and Artic. The conference calls bring researchers together to discuss progress and issues associated with their research projects or the transition of products to operations. Some relevant outcomes noted over the past year:

--Collaborations with Eric Stevens, from the Geographic Information Network of Alaska (GINA) at the University of Alaska, focused on the use of NUCAPS soundings for the NUCAPS initiative and the Alaska Fire Initiative. As part of this effort, quick-guides were developed for “NUCAPS in AWIPS II: How to Access Data & Edit Soundings” and “How To Access Pop-Up Skew-T Data”. There are plans to incorporate these into the Integrated Training Tool (ITT) which was developed by SPoRT for AWIPS-II version 16.4.1. The quick guides are located at the following link.
ftp://rammftp.cira.colostate.edu/torres/Quick_Guide/



Figure 1. NUCAPS in AWIPS-II Quick Guide.

-- Participation in the Field Campaign during the Spring and Summer 2016: 'Improving NUCAPS Soundings for CONUS Severe Weather Applications via Data Fusion' field campaign. As part of this experiment, radiosondes were launched across the Colorado Front Range to provide in-situ measurements to compare with NUCAPS derived soundings. Partners on the project include D. Lindsey, J. Dostalek, J. Haynes, C. Barnet, D. Nietfeld and G. Chirokova.

-- Near-Constant Contrast Imagery of the May 2016 Fort McMurray Wildfires was presented at the 10 June 'Fire and Smoke' Initiative call. The imagery highlighted the utility and capabilities of NCC and how forecasters can access the data in the AWIPS-II interface. This imagery and discussion points were posted on the VISIT Blog in late May.

-- One of the ways to test the flow of imagery and products into the Advanced Weather Interactive Processing System (AWIPS) environment is through Data Operations Exercises (DOE) conducted by the Total Operational Weather Readiness – Satellites (TOWR-S) Group. On the Fire and Smoke Initiative teleconference on 20 October, Aerosol Detection information was shared with researchers A. Huff and S. Kondragunta. This included the locations of participating DOE-4 sites at Weather Forecast Offices (WFOs) and the upcoming polar products relevant to them (e.g. Active Fires and Aerosol Detection) that will be flowing into AWIPS-II. Of particular concern is a terrain correction that is needed for the Near Constant Contrast (NCC) product derived from the Day-Night Band (DNB) on the VIIRS instrument. The CIRA JPSS Visualization and Imagery Team is expediting this process.

-- On the 10 October 2016 NUCAPS call, feedback from the GOES-R/JPSS Satellite workshop held in conjunction with the 41st Annual National Weather Association Meeting on 13 September in Norfolk, Virginia was used to plan for the “Experiencing JPSS Capabilities” Short Course held in association with the 97th American Meteorological Society Meeting on 21 January in Seattle, Washington.

2-- Interact and collaborate with training partners: the NWS Office of the Chief Learning Officer (OCLO), the VISIT and SHyMet training programs, COMET, Satellite liaisons.

Background: The primary user that this project targets for training is the NWS forecaster. The NWS Office of the Chief Learning Officer (OCLO) oversees training of its employees and has several divisions devoted to this task: The Training Center (NWSTC), the Warning Decision Training Division (WDTD), and the Forecast Decision Training Division (FDTD). The NWS OCLO designed and launched a Satellite

Foundation Course for GOES-R/16 (SatFC-G) and is planning a similar type of foundation course for JPSS. A Satellite Training Advisory Team (STAT) consisting of Science Operations Officers (SOOs), satellite liaisons, representatives from the NWS OCLO, and training developers, were brought together to guide the design, development, tracking, review, and implementation of the course. Training developers included those associated with the VISIT and SHyMet programs at the Cooperative Institute for Research in the Atmosphere (CIRA) and the Cooperative Institute for Meteorological Satellite Studies (CIMSS), as well as COMET, the Short-term Prediction Research and Transition Center (SPoRT), the Cooperative Institute for Mesoscale Meteorological Studies (CIMMS), and OCLO.

--During the past year, this project participated in weekly STAT calls to provide input on the development of the SatFC-J and to observe the process for the SatFC-G in order to gather feedback relevant to the design of the SatFC-J. The progress of SatFC-J is presented in objective 3 below.

--Participation in virtual meetings of the Total Operational Weather Readiness – Satellites (TOWR-S) project to keep abreast of the deployment timelines of JPSS imagery and products that are planned for broadcast over the Satellite Broadcast Network (SBN) for use in AWIPS-II. The intent of tracking the timelines for product availability in AWIPS-II is to ensure that user training is also available.

--CIRA local interactions with NOAA personnel ensure data access and display capabilities on AWIPS-II to be able to adequately address training activities.

--CIRA hosted and participated in the 'AWIPS-II Experimental Products Development Team (EPDT) Introduction Class Fall 2016'. The 3-day course was held 7-9 December 2016 and was led by S. Longmore (CIRA) and D. Molenaar (NOAA/STAR/RAMMB at CIRA). J. Torres and D. Bikos (both at CIRA) presented 'Weather Event Simulator-2 (WES-2) Demonstration' on 9 December. Users were shown how to process polar-orbiting data ingested by the Satellite Broadcast Network (SBN). Once the data is processed, the user can then create and save case studies in the Weather Event Simulator-2 (WES-2).

3--Review draft JPSS Formal Training Program (Draft provided by Bill Ward and Jordan Gerth, January 2016), map existing training and user training needs; prepare JPSS training tracking spreadsheet.

-- Using the "Plan for Formal Training Program on the Joint Polar Satellite System (JPSS) and Global Change Observation Mission (GCOM) for National Weather Service Operational Meteorologists by Bill Ward and Jordan Gerth (January, 2016)", a first draft of the Satellite Foundation Course for JPSS (SatFC-J) training tracking spreadsheet was prepared in May 2016. The targeted length for the foundational course is 4 hours with the goal of having the course available to forecasters by the launch of JPSS-1.

--During a STAT meeting held 6-9 September in Boulder, Co, training groups were matched to the 3 overarching objectives that were captured in the training tracking spreadsheet. (see Figure 2 at right for objectives)

-- During the last quarter of calendar year 2016, a list of JPSS relevant training objectives was initiated to be used to direct training. The various training groups at CIRA, CIMSS, COMET, and SPoRT have reviewed and made contributions to the list. The list has been shared with SOOs to get their feedback.

Figure 2. Satellite Foundation Course for JPSS (SatFC-J) Training Plan Overview

Objective 1: Introducing Suomi-NPP, JPSS, GCOM, GPM

Objective 2: Introduction to Microwave Remote Sensing

Objective 3: Basic Forecast Applications

(Optional) Product Applications:

Section 1: Fires/Ash/Aerosols

Section 2: Rain Rate/TPW

Section 3: Cryosphere

Section 4: Wind/Waves

Section 5: Additional Products

--It is noted that in December 2016, the STAT group started receiving feedback on both the GOES-R preparatory course for SOOs and from the SatFC for GOES-R. Around the same time it was announced that JPSS-1 would launch no earlier than the 4th Quarter of FY 17. In light of both feedback and delayed launch, the rapid development of training materials was essentially put on hold pending review of feedback and assessment of the way forward to improve the design, development, and implementation of SatFC-J. An in-person meeting of the STAT team for SatFC-J is scheduled for the last week in April 2017.

4--Prepare training materials based on interactions with users, developers, and understanding of training requirements.

--Blogs

The following Blogs highlighted imagery and products associated with the NCC imagery, River and Ice Flooding, Fire and Smoke, NUCAPS, and Artic and have been posted on the VISIT site:

<http://rammb.cira.colostate.edu/training/visit/blog/>

- Madagascar: Tropical Cyclone Enawo
- 7-8 February 2017, New Orleans Power Outage
- More Precipitation for the West Coast, 3 February 2017
- Post Atmospheric River Events in California, 011317
- Lake Effect Snow: Buffalo and Rochester, NY, 121416-121516
- Nantahala National Forest Wildfires 11-11-16
- South-Central Colorado: Junkins Fire
- Hurricane Matthew 100616
- 19 June - 8 July 2016: Beaver Creek Fire, Jackson County, Colorado
- NCC Imagery, Colorado Fires in July
- VIIRS Flood Detection Product: Gulf Coast Flooding, August 2016
- Hurricane Season in the Atlantic: Invest Area 99L and TS Gaston
- Puerto Rico Power Outage
- Fort McMurray Wildfires and the Near-Constant Contrast (NCC) Imagery
- NUCAPS, Part One: Introduction
- NUCAPS, Part Two: Field Campaign and Observations
- Synthetic Imagery from the NAM Alaska Nest 4 km

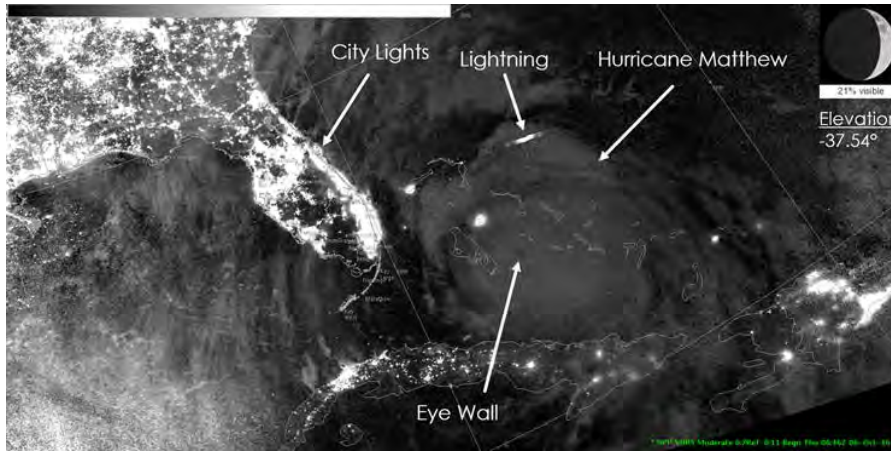

Figure 3. The NCC product showing various features of Hurricane Matthew (lightning and the eyewall) and city lights.

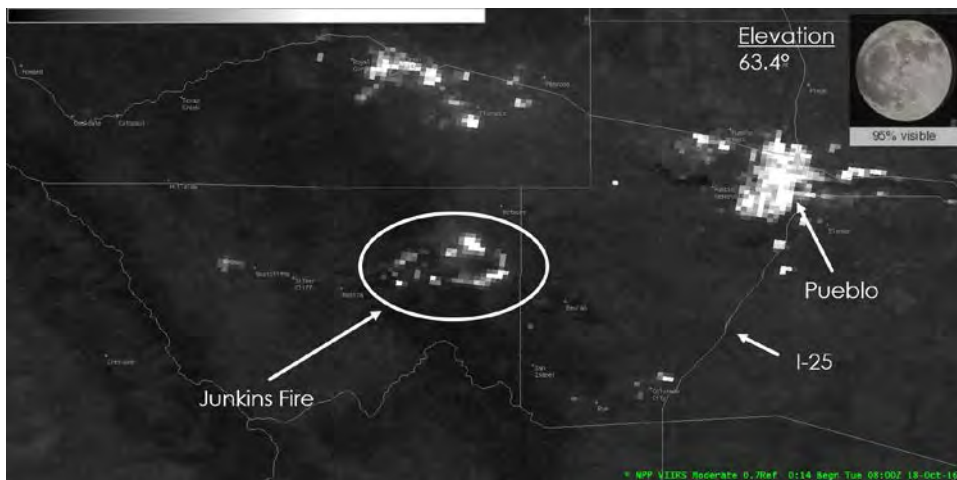

Figure 4. The NCC product showing the Junkins fire compared with nearby city lights.

--Modules

- Development has begun on two of the modules for the SatFC-J course: "Basics of Microwave Remote Sensing" and "Oxygen and water vapor absorption bands".

5--Participate in Domestic Science Conferences (NWA/AGU/AMS) and travel locally to Boulder, Colorado and Cheyenne, Wyoming WFOs

-- See the presentations listed below.

-- Participation in the 3rd NOAA Satellite Proving Ground/User-Readiness Meeting from 9-13 May 2016 held at the National Weather Center in Norman, Oklahoma.

-- Participation in the OCONUS Direct Broadcast (DB) Workshop and Proving Ground Meeting in Honolulu, Hawaii on 27-30 June 2016.

-- Participation in the Satellite Training Advisory Team (STAT) meeting in Boulder, Colorado, 6-9 September 2016.

-- Assistance provided for logistics, data collection, and production of the webpage as well as attendance at the NWA GOES-R/JPSS Satellite Workshop held on 13 September 2016.

-- Visit to WFO-Boulder to attend their Winter Weather Workshop, Boulder, Colorado, 7 October 2016.

Information was presented on 'JPSS in Operations'. Forecasters were given access to the presentations, supplemental links, and quick guides.

-- Visit to WFO-Cheyenne, Cheyenne, Wyoming, 1 December 2016. Met with R. Cox (SOO, WFO-Cheyenne) and his team, gave them access to the presentations and the quick guides involving NUCAPS

and NCC. Also, debriefed them on the Integrated Training Tool (ITT) that will be able to help forecasters utilize on-the-spot training guides in AWIPS-II. The ITT will be in the new AWIPS-II build 16.4.1 coming out in early 2017.

-- Public outreach opportunity: Radiosondes were launched from Poudre High School and the Fort Collins Museum of Discovery on two separate days in June. Both are located in Fort Collins, Colorado. This was part of the 'Improving NUCAPS Soundings for CONUS Severe Weather Applications via Data Fusion' field campaign, which is launching radiosondes across the Colorado Front Range in order to compare temperature and moisture profiles from radiosondes with satellite derived NUCAPS sounding profiles.

Publications: None

Presentations:

Bikos, D. and J. Torres: Training on the Weather Event Simulator (WES-2) provided for the Experimental Products Development Team at CIRA, 9 December 2016.

Connell, B., D. Bikos, S. Lindstrom, E.J. Szoke, S. Bachmeier, J. Torres, E. Dagg, T. Mostek, B. Motta, M. Davison, and L. Veeck, 2016: Satellite User Readiness Through Training: VISIT, SHyMet, and WMO VLab. AMS 21st Satellite Meteorology Conference, Madison, WI, 15-19 August. Poster.

Connell, B., D. Bikos, S. Lindstrom, J. Torres, E. J. Szoke, E. L. Dagg, A. B. Schumacher, A. S. Bachmeier, A. Mostek, B. C. Motta, M. Davison, and L. Veeck, 2017: Satellite user readiness through training: VISIT, SHyMet, WMO VLab and liaisons. 13th Annual Symposium on New Generation Operational Environmental Satellite Systems, Seattle, WA, Amer. Meteor. Soc., 23-26 January 2017. Presentation.

Szoke, E., D. Bikos, R. Brummer, H. Gosden, D. Molenaar, D. Hillger, S. Miller, D. Lindsey, J. Tores and C. Seaman, 2016: What happens next for CIRA's NWS Proving Ground activities after the launch of GOES-R. 41st NWA Annual Meeting, Norfolk, VA, 12-15 September. Poster.

Torres, J. 2016: JPSS in Operations. SOO Development Course. Norman, OK, 22-23 August. Presentation.

Torres, J. 2017: NOAA CLASS Demonstration. AMS Short Course: Experiencing JPSS Capabilities. Seattle, Amer. Meteor. Soc., 21 January 2017. Presentation.

Torres, J. 2016: JPSS Training. 2016 Annual Science Team Meeting. College Park, MD, 8-12 August. Presentation.

Torres, J., B. Connell, and S. Miller, 2016: Uniqueness of JPSS Products for NWS decision support activities. AMS 21st Satellite Meteorology Conference, Madison, WI, 15-19 August. Poster.

Torres, J., B. Connell, and S. Miller, 2016: JPSS Imagery and Products in AWIPS-II for NWS Forecasters. 41st NWA Annual Meeting, Norfolk, VA, 12-15 September. Poster.

Torres, J., B. Connell, and S. Miller, 2017: Utility of JPSS Products for NWS Forecasters. 13th Annual Symposium on New Generation Operational Environmental Satellite Systems, Seattle, WA, Amer. Meteor. Soc., 23-26 January 2017. Presentation.

PROJECT TITLE: CIRA Support to the JPSS StAR Science Program: S-NPP VIIRS EDR Imagery Algorithm and Validation Activities and S-NPP VIIRS Cloud Validation

PRINCIPAL INVESTIGATOR: Steve Miller

RESEARCH TEAM: Yoo-Jeong Noh, Curtis Seaman, Matt Rogers, John Forsythe, Scott Longmore, Louie Grasso, Stan Kidder, Steve Finley, Natalie Tourville, Hiro Gosden, Dave Watson, Kevin Micke, Renate Brummer, Rosemary Borger

NOAA TECHNICAL CONTACT: Satya Kalluri (NOAA/NESDIS) and Lihang Zhou (NOAA/NESDIS)

NOAA RESEARCH TEAM: Don Hillger, Dan Lindsey (NOAA/NESDIS/STAR/RAMMB)

FISCAL YEAR FUNDING: \$432,126

PROJECT OBJECTIVES:

The Suomi National Polar-orbiting Partnership mission (NPP), serving as risk-reduction to the Joint Polar Satellite System (JPSS) and providing continuity to the National Aeronautics and Space Administration's (NASA) Earth Observing System (EOS) climate mission, was launched successfully on 28 October 2011. The Visible/Infrared Imaging Radiometer Suite (VIIRS) on board Suomi NPP provides atmospheric, cloud, and surface imagery for both weather and climate applications. VIIRS is the next-generation to the Advanced Very High-Resolution Radiometer (AVHRR) that has flown on board the Polar-Orbiting Environmental Satellites (POES) since NOAA-15 in 1998. VIIRS was originally designed to merge the capabilities of the Defense Meteorological Satellite Program (DMSP) Operational Linescan System (OLS) and the NASA Moderate-resolution Imaging Spectroradiometer (MODIS).

This is a multi-agency research project with teams involved from NOAA/NESDIS/STAR, CIRA, CIMSS, NRL, NCEI-Boulder, NGAS, and Aerospace. CIRA's research in this area is divided into two distinct elements: Project I) Support of VIIRS Imagery Validation Activities and Project II) Support of VIIRS Cloud Validation Activities. Progress on each element is detailed below.

These projects directly address NOAA's Weather and Water goal, which seeks to serve society's needs for weather and water information. This research also falls within the NOAA-defined CIRA thematic area of Satellite Algorithm Development, Training and Education, as calibration/validation is an integral and critical first step in the algorithm development process. Outcomes of the current research may in some cases lead to adjustments in the original algorithm to correct issues discovered during the calibration/validation analysis.

Project 1--Support of the VIIRS Imagery Validation Activities

Research Objectives:

- 1-- Report on the analysis of the VIIRS Imagery EDR software, imagery, and image products produced from that imagery – Either as uncovered, or end of term.
- 2-- Document any EDR software and imagery issues that might be uncovered, whether in the image data, or products derived from that imagery – Either as uncovered, or end of term.
- 3-- Contribute to StAR long-term monitoring website, with Imagery products over either CONUS or Alaska.
- 4-- Provide real-time web displays of VIIRS imagery and products that will serve as a source of material for training of NWS and other meteorologists, especially for those spectral bands that are new to the operational satellite data stream.

5-- Provide monthly reports on the VIIRS Imagery EDR Team activities and spending

Achievements:

1--When changes to the JPSS ground system are made, test data are provided to the VIIRS Imagery Team for analysis. Reports of the findings are provided to the JPSS Program Office.

2--VIIRS imagery is produced in near real-time on the RAMSDIS Online website, as well as on location at the various partner agencies and institutes (NRL, CIMSS, NCEI-Boulder, etc.), and this imagery is routinely monitored for artifacts. One example VIIRS artifact is shown in Figure 1. These events are documented and reported to the JPSS Program Office. Presentations are provided at the STAR JPSS Annual Science Team Meeting, which is held every August. We work with the VIIRS SDR Team and JPSS Program Office to resolve any issues with the imagery.

3--VIIRS Day/Night Band (DNB) imagery is produced on a daily basis for the STAR JPSS Long Term Monitoring (LTM) website (https://www.star.nesdis.noaa.gov/jpss/EDRs/products_Imagery.php). This imagery includes nighttime DNB imagery over Alaska, which has been defined by the JPSS Program as a Key Performance Parameter (KPP). An example is shown in Figure 2.

4--VIIRS images and imagery products are produced in near real-time on the RAMSDIS Online website. The imagery and its applications are discussed on various blogs, including the VIIRS Imagery and Visualization Team Blog (<http://rammb.cira.colostate.edu/projects/npp/blog/>), the Seeing the Light: VIIRS in the Arctic Blog (<http://rammb.cira.colostate.edu/projects/alaska/blog/>), and the VISIT Meteorological Interpretation Blog (<http://rammb.cira.colostate.edu/training/visit/blog/>). Collectively, these blogs have featured 19 blog posts discussing VIIRS imagery and its applications in the past year.

Team members provide a VIIRS “Image of the Month” to the JPSS Program Office. VIIRS images are also provided to various media and social media outlets (Figure 3), including the @NOAASatellites Twitter and Facebook accounts whenever high impact weather or interesting images occur and upon request.

5--Monthly teleconferences are held with all participating Imagery Team members. Reports on VIIRS Imagery Team activities are provided on a weekly, monthly and quarterly basis.

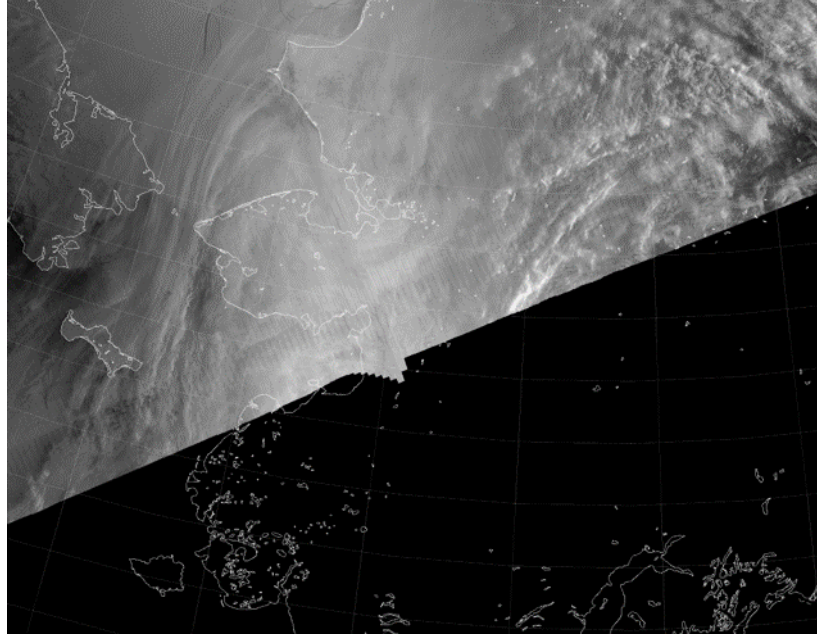

Figure 1. An attitude error causes a shift in the instrument scans relative to the nominal VIIRS swath (16:04 UTC 25 March 2016).

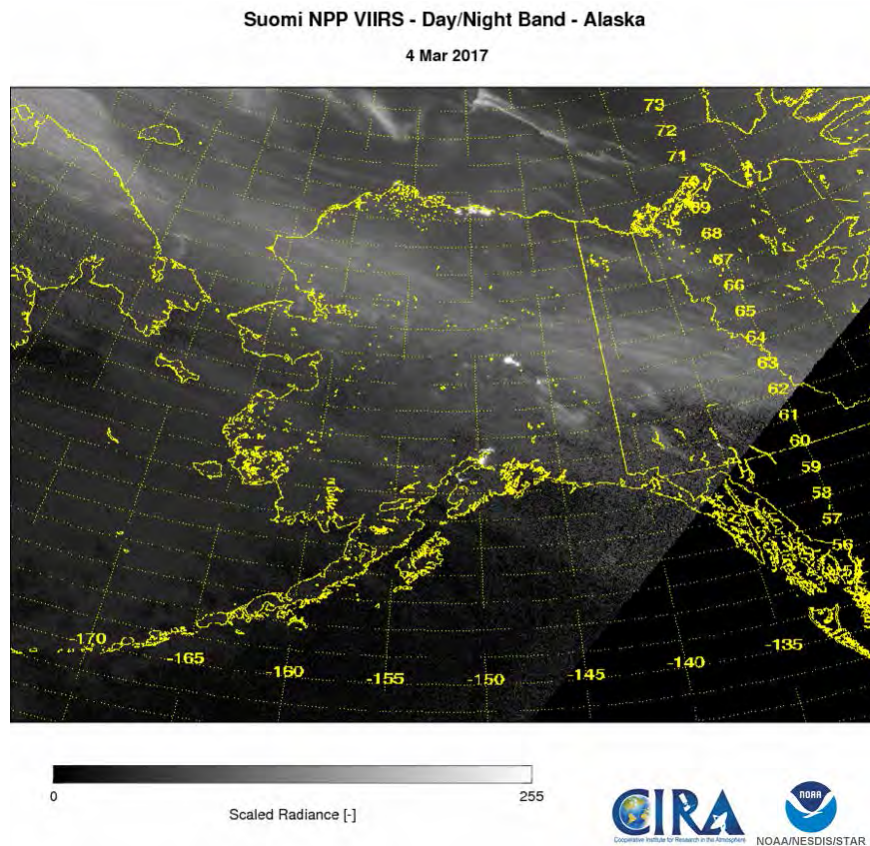

Figure 2. Example DNB image provided to the STAR JPSS LTM website (4 March 2017).

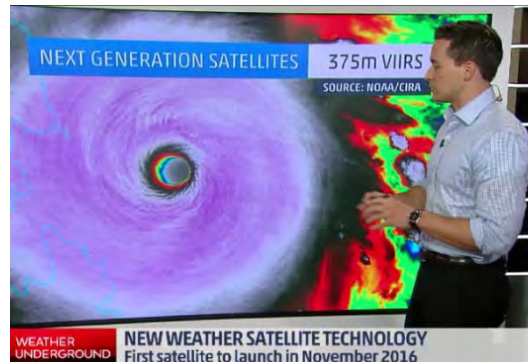

Figure 3: CIRA-produced VIIRS image shown on The Weather Channel.

Project 2--Support of the VIIRS Cloud Validation Activities

Research Objectives:

- 1-- Demonstrate and continue to quality control a revised cloud geometric thickness algorithm based on statistical, semi-empirical, and model-fusion techniques, which has been adopted as the NOAA Enterprise algorithm and supplant the currently operational IDPS algorithm for calculating Cloud Base Height (CBH)
- 2-- Examine algorithm refinements: i) improved performance in deep convective clouds using climatological data, and ii) improved performance in thin cirrus clouds using retrieved optical thickness and CloudSat/CALIPSO data
- 3-- Prepare, submit, and shepherd through the peer-review process scientific journal articles
- 4-- Support the JPSS VIIRS Cloud Cal/Val Team in its transition of the revised algorithm software to the operational NOAA Enterprise environment, and confirm its correct operation.
- 5- Support the JPSS VIIRS CloudCal/Val Team in its development of an enhanced Cloud Cover and Layers product suitable for use by operational users such as the Aviation Weather Center and the Alaska Region.
- 6-- Continue to evaluate nighttime CBH leveraging NLCOMP nighttime cloud optical thickness using Atmospheric Radiation Measurement (ARM) program active sensor measurements, focusing on lidar data from the Northern Slope of Alaska (NSA) and Southern Great Plains (SGP) sites. Support the JPSS VIIRS Cloud Cal/Val Team in any other developments related to nighttime cloud properties and associated applications.
- 7-- Prepare reports, contribute materials to presentations, and participate in conferences as requested/coordinated by Team Lead.

Achievements:

- 1--We continue the algorithm enhancements for optimal CGT and CBH estimates. A few modifications of the algorithm codes have been implemented with support from CIMSS colleagues to improve error flags and cloud base for deep convective clouds. The Algorithm Theoretical Basis Document (ATBD) has been updated accordingly.

2--The performance evaluations which have been conducted against CloudSat were extended by adding CALIPSO data. The 2B-GEOPROF-LIDAR product is no longer available since the CloudSat battery anomaly in 2011, which made it difficult to maintain tight formation flying of CALIPSO and CloudSat, but they are still within the same orbit. The matchup validation tool has been updated to accommodate CALIPSO data (Level2 1-km Cloud Layer product) for more robust validation. Considering each sensor's characteristics in detecting clouds, CALIPSO data was utilized particularly for optically thin clouds and low water clouds that are often missed by CloudSat. The algorithm performance has been reconfirmed by combining CloudSat/CALIPSO data as shown in Figure 4. For September-October 2013 matchup cases, the number of detected clouds greatly increases from 5518 to 8738 profiles (within spec) by CALIPSO for thin clouds and from 8730 to 40840 for low water clouds.

3--Two journal papers submitted to Journal of Atmospheric and Oceanic Technology are now in print, which are detailing: i) evaluation of the IDPS CBH environmental data record against CloudSat (led by Curtis Seaman), and ii) description and demonstration of new algorithm for CBH estimation (led by Yoo-Jeong Noh).

4--Since the first version of the CBH algorithm as part of the NOAA Enterprise cloud algorithms was delivered to The NESDIS/STAR Algorithm Scientific Software Integration and System Transition Team (ASSISTT) last year, the algorithm is being tested in the NOAA operational environment. The CIRA and CIMSS teams continue to examine the ASSISTT output and provide feedback/updates for its correct operation and monitoring within the operational frame.

5--In collaboration with CIMSS, the CGT information has been added to the CCL algorithm in the CLAVR-x system which previously employed the cloud top data only. Figure 5 shows an example of the improved VIIRS layer cloud fractions implemented at CIRA into AWIPS II (11 May 2016 at 1202 UTC). The CBH information can be used to modulate the layered cloud fraction (high/mid/low) by introducing additional cloud coverage at lower levels of the profile often missed by the old CCL retrieval. We have received feedback about our products from AWC Satellite Liaison Amanda Terborg and discussed potential collaborations for the algorithm improvement.

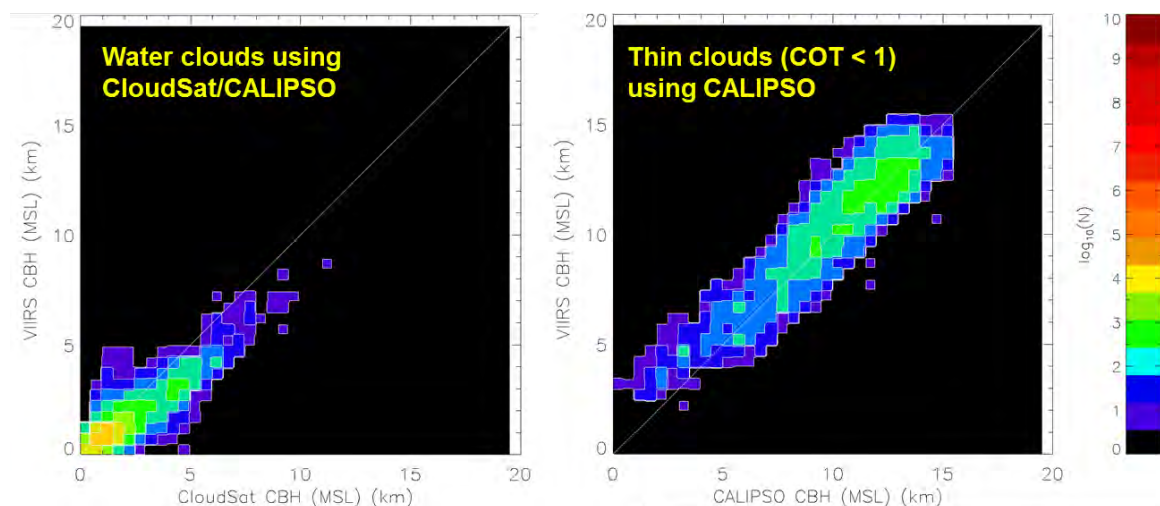

Figure 4. Two-dimensional histograms (scatterplots) of VIIRS-retrieved and A-Train-observed CBHs for September – October 2013 matchups. CloudSat/CALIPSO combined data are used for water clouds (left), and CALIPSO only data are compared with VIIRS CBHs for optically thin clouds (right), considering the detection characteristics of the sensors. Colors represent the number of matching points (N) per bin on the logarithmic scale provided, and are valid for all cloud types globally where the cloud top height retrieval was accurate (within spec: CTH errors less than 1 km for optically thick clouds and less than 2 km for optically thin clouds).

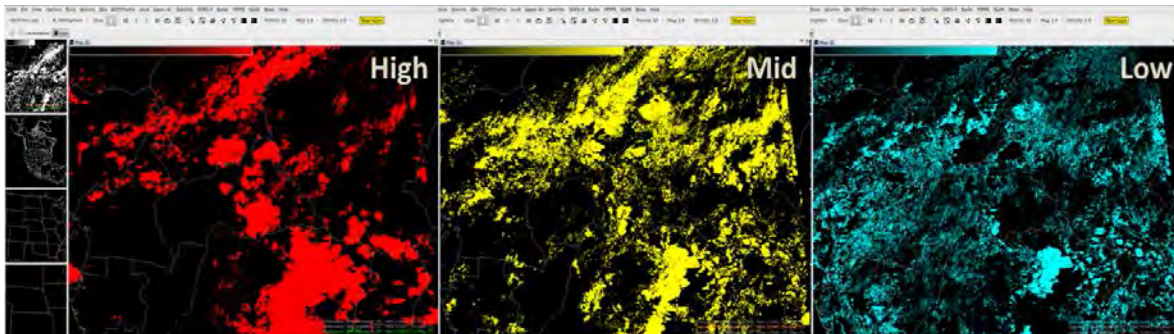

Figure 5. AWIPS II display of the new VIIRS Cloud Cover Layers products improved by using the cloud base information.

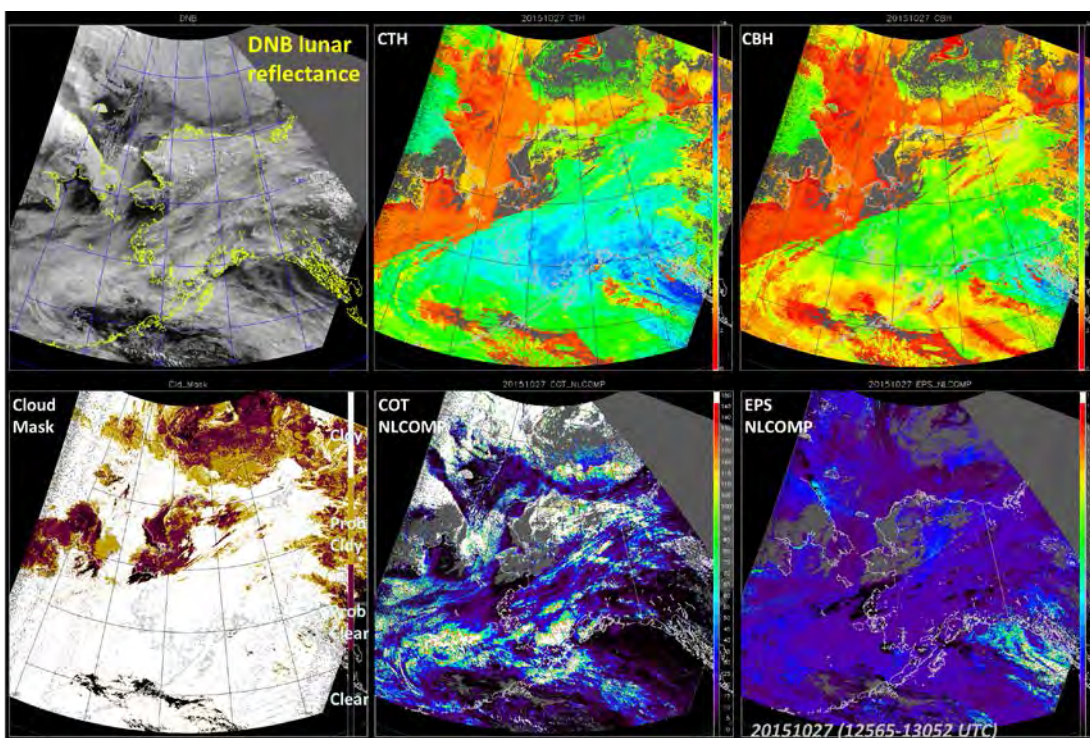

Figure 6. Nighttime cloud properties utilizing lunar reflectances from VIIRS DNB (with supplementary NWP data) over Alaska on 27 October 2015 (1256 – 1305 UTC).

6--Nighttime cloud properties for CBH are retrieved by utilizing lunar reflectances from VIIRS DNB data with supplementary NWP data (Figure 6). Since CloudSat is operational during daytime only due to a battery anomaly, ground-based measurements at the Atmospheric Radiation Measurement (ARM) sites have been utilized to assess the performance of the CBH algorithm at night. Data from ceilometer and micropulse lidar (MPL) at the ARM site on the North Slope of Alaska (NSA) were compared with nighttime VIIRS CBHs as shown in Figure 7 (polar winter in 2015-2016). A matchup window of 1-km distance and 5-minute time lag is used between ARM and VIIRS data. Local weather conditions are checked using temperature and precipitation observations at the site. CALIPSO data with near-simultaneous collocation are added for multi-layered cloud cases which may have high clouds aloft beyond the ground measurements. From the comparison, it was obtained $r^2 = 0.47$ for ceilometer CBHs and $r^2 = 0.41$ for

MPL CBHs when CTHs from MPL and VIIRS are within 2-km error range. Precipitation cases were excluded in the analysis. We continue to conduct multi-month statistical analyses of performance and case studies. The preliminary validation results were presented at the AGU annual meeting.

7--The CIRA team participated in the VIIRS Cloud Cal/Val teleconferences and regularly contributed input materials to Andrew Heidinger for team reviews and reports to support the JPSS VIIRS Cloud Cal/Val Team. An overview presentation of the CBH and CCL algorithms and Cal/Val activities was given at 2016 STAR JPSS Annual Science Team Meeting.

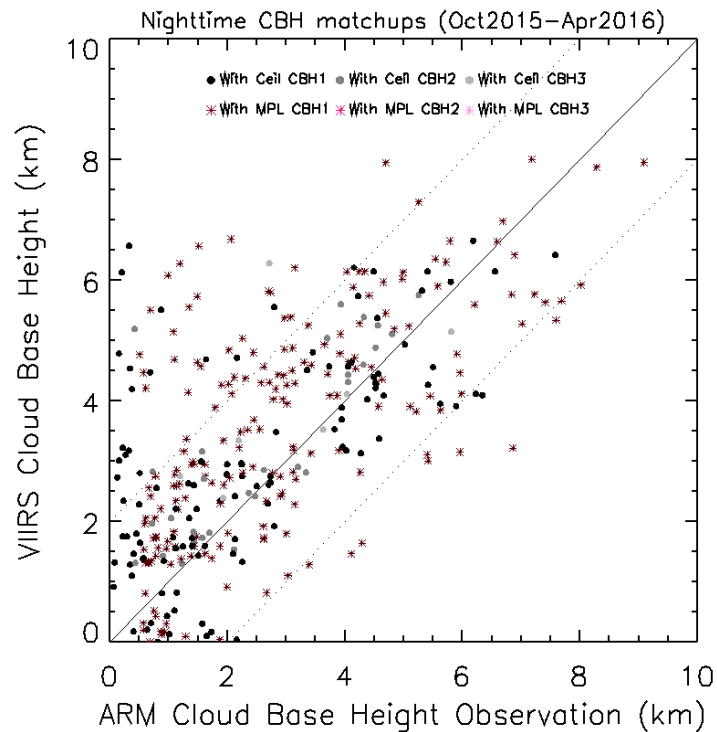

Figure 7. Initial evaluation results for nighttime CBH algorithm performance using ARM ceilometer data from the NSA site. The brown/red symbols represent comparisons with ARM MPL CBHs and black/gray circles are ARM ceilometer CBHs (black for the first layer and gray for the second layer). CBH measurements are considered only when CTHs from MPL and VIIRS are within 2-km error range.

Publications:

Albrecht, R., S. Goodman, D. Buechler, R. Blakeslee, and H. Christian, 2016: Where are the lightning hotspots on Earth? *Bull. Amer. Meteor. Soc.*, 97(11). doi:10.1175/BAMS-D-14-00193.1, NOTE: BAMS Cover Image by Steve Miller

Hillger, D. W., T. Kopp, C. J. Seaman, S. D. Miller, D. T. Lindsey, E. Stevens, J. Solbrig, W. Straka III, M. Kreller, A. Kuciauskas, and A. Terborg, 2016: User Validation of VIIRS Satellite Imagery. *Remote Sensing*, 8(11); doi:10.3390/rs8010011

Lai, C., J. Yue; J. Xu; W. Straka III; S. D. Miller; X. Liu, 2017: Suomi NPP VIIRS/DNB imagery of nightglow gravity waves from various sources over China. *Advances in Space Research*, in press. Manuscript Number: ASR-D-16-00683R1; Section: EM -Earth Magnetosphere/Upper Atmosphere.

Mills, S. and S. D. Miller, 2016: VIIRS Day/Night Band—Correcting striping and nonuniformity over a very large dynamic range. *J. Imaging* 2016, 2(1), 9; doi:10.3390/jimaging2010009

Noh, Y. J., J. M. Forsythe, S. D. Miller, C. J. Seaman, Y. Li, A. K. Heidinger, D. T. Lindsey, M. A. Rogers, and P. T. Partain, 2017: Cloud base height estimation from VIIRS. Part II: A statistical algorithm based on A-Train satellite data. *J. Atmos. Ocean. Tech.*, doi: 10.1175/JTECH-D-16-0110.1.

Seaman, C. J., Y. J. Noh, S. D. Miller, A. K. Heidinger, and D. T. Lindsey, 2017: Cloud base height estimation from VIIRS. Part I: Operational algorithm validation against CloudSat. *J. Atmos. Ocean. Tech.*, doi: 10.1175/JTECH-D-16-0109.1.

Presentations:

Chirokova, G., J. Knaff, D. Lindsey, R. DeMaria, M. DeMaria and J. Bevin, 2016: Tropical Cyclone Uses of VIIRS. STAR JPSS Annual Science Team Meeting, College Park, MD, 8-12 August 2016.

Hillger, D., 2016: VIIRS Imagery EDR Overview. STAR JPSS Annual Science Team Meeting, College Park, MD, 8-12 August 2016.

Hillger, D. W., T. J. Kopp, C. J. Seaman, S. D. Miller, D. T. Lindsey and J. Torres, 2017: Validating VIIRS Imagery from JPSS-1. 97th AMS Annual Meeting, Seattle, WA, 23-26 January 2017.

Miller, S. D., 2016: Day-Night Band. Science presentation for visitors of Chengdu University of Information Technology. Meeting held at CSU, Lory Student Center, Fort Collins, CO, July 2016.

Miller, S.D., 2016: Satellite Research and Application Development at CIRA. NOAA/NESDIS CoRP Science Symposium, CIRA Science Project Overview. CIRA Executive Board Meeting, Fort Collins, CO, May 2016.

Miller, S.D., 2016: Taking Back the Night with the VIIRS Day/Night Band. Invited presentation at NOAA Exhibit Booth. AGU Annual Fall Meeting, San Francisco, 12-16 December 2016.

Miller, S. D., C. Combs, W. C. Straka III, C. J. Seaman, M. Setvak, A. Heidinger, A. Walther, Y. J. Noh, 2016: Advances in Day/Night Band Science and Applications: Making Good on Promises of the Moon. Joint 21st AMS Satellite Meteorology, Oceanography, and Climatology Conference, Madison, WI, 15-18 August 2016. Invited Key-Note Presentation

Miller, S. D., C. J. Seaman, C. Combs, J. Solbrig, W. Straka, A. Walther, Y-J. Noh, A. Heidinger, 2016: Status and Prospects for Low-Light Visible Sensing from the VIIRS Day/Night Band on Suomi NPP and JPSS-1. AGU Annual Fall Meeting, San Francisco, 12-16 December 2016.

Noh, Y. J., 2016: Use of satellite and in-situ observations for evaluating and improving the representation of cloud processes in NWP models. 4th International workshop on next-generation NWP models: gray-zone and advanced approaches for high-impact weather, Jeju, Korea, 25-27 May 2016.

Noh, Y. J., S. D. Miller, J. M. Forsythe, C. J. Seaman, D. T. Lindsey, A. K. Heidinger, and Y. Li, 2016: The newly operational VIIRS Cloud Base and CCL (Cloud Cover/Layers). STAR JPSS Annual Science Team Meeting, College Park, MD, 8-12 August 2016.

Noh, Y. J., S. D. Miller, C. J. Seaman, J. M. Forsythe, D. T. Lindsey, A. K. Heidinger, and Y. Li, 2016: Improvement of Satellite Cloud Base Height and Cloud Cover/Layers Products. 7th Asia-Oceania/2nd AMS-Asia/2nd KMA Meteorological Satellite Users' Conference, Songdo City, Incheon, Korea, 21-28 October 2016.

Noh, Y. J., S. D. Miller, C. J. Seaman, J. M. Forsythe, R. Brummer, D. T. Lindsey, A. Walther, A. K. Heidinger, and Y. Li, 2016: Validation of VIIRS cloud base heights at night using ground and satellite measurements over Alaska. 2016 AGU Fall Meeting, San Francisco, CA, 12-16 December 2016.

Seaman, C. J., D. T. Lindsey, S. D. Miller, J. A. Knaff, G. Chirokova, J. F. Dostalek, A. B. Schumacher, K. M. Musgrave, L. D. Grasso, J. Forsythe, R. DeMaria, D. A. Molenaar, 2016: CIRA/RAMMB Research Activities in Support of the OCONUS. OCONUS Technical Interchange Meeting, Honolulu, HI, June 2016.

Seaman, C. J., S. D. Miller, W. C. Straka III, 2016: Illuminating the Capabilities of the VIIRS Day/Night Band in the High Latitudes. 2016 EUMETSAT Meteorological Satellite Conference, Darmstadt, Germany, 26-30 September 2016.

Seaman, C., S. Miller, J. Torres, D. Hillger and D. Lindsey, 2016: VIIRS Imagery Applications at CIRA. STAR JPSS Annual Science Team Meeting, College Park, MD, 8-12 August 2016.

Seaman, C. J., S. D. Miller, D. T. Lindsey and D. W. Hillger, 2017: JPSS and GOES-R Multispectral Imagery Applications and Product Development at CIRA. 97th AMS Annual Meeting, Seattle, WA, 23-26 January 2017.

Seaman, C. J. and W. Straka, III, 2017: Night Vision: Illuminating the Capabilities of the VIIRS Day/Night Band. 97th AMS Annual Meeting, Seattle, WA, 23-26 January 2017. (Invited NOAA Exhibit Booth presentation).

Torres, J., 2016: JPSS Training Plan. STAR JPSS Annual Science Team Meeting, College Park, MD, 8-12 August 2016.

Torres, J., B. Connell, and S. Miller: "JPSS Imagery and Products Available in AWIPS-II for NWS Forecasters." 41st Annual National Weather Association Meeting, Norfolk, VA, 10-15 September 2016. Oral Presentation.

Torres, J., B. H. Connell, and S. D. Miller, 2017: Utility of JPSS Products for NWS Forecasters. 97th AMS Annual Meeting, Seattle, WA, 23-26 January 2017.



PROJECT TITLE: CIRA Support of NOAA's Commitment to the Coordination Group for Meteorological Satellites: Enhancing the International Virtual Laboratory

PRINCIPAL INVESTIGATORS: Bernadette Connell

RESEARCH TEAM: Luciane Veeck, Erin Dagg, and Dan Bikos

TECHNICAL CONTACT: Satya Kalluri (NOAA/NESDIS) and Candice Jongsma (NOAA/OAR)

NOAA RESEARCH TEAM: Anthony Mostek NOAA/ NWS/OCWWS Training Division

FISCAL YEAR FUNDING: \$35,000

PROJECT OBJECTIVES:

The World Meteorological Organization (WMO) Virtual Laboratory for Education and Training in Satellite Meteorology (VLab) is a collaborative effort joining major operational satellite operators across the globe

with WMO regional training centers of excellence in satellite meteorology. Those regional training centers serve as the satellite-focused training resource for WMO Members. Through its cooperative institute for Research in the Atmosphere (CIRA) at Colorado State University (CSU), NOAA/NESDIS sponsors Regional Training Centers of Excellence (CoE) in Argentina, Barbados, Brazil, and Costa Rica. The top-level objectives of the VLab are:

- 1--To provide high quality and up-to-date training and supporting resources on current and future meteorological and other environmental satellite systems, data, products and applications;
- 2--To enable the regional training centers to facilitate and foster research and the development of socio-economic applications at the local level through the National Meteorological and Hydrological Services. Enhanced training and coordination of training accomplished under this project will prepare forecasters, researchers, and managers on how to utilize imagery and products to provide services and training in these areas.

Specific Objectives:

- 1--Participate in the bi-annual meeting in Barbados in May 2016 and quarterly virtual meetings of the WMO VLab Management Group (VLMG).
- 2--Provide partial support for the WMO Technical Support Officer position.
- 3--Provide virtual JPSS imagery and product examples and partial support for monthly international virtual Regional Focus Group sessions.
- 4--Participate in the GNC-A coordination group, and evaluate JPSS/LEO products to be made available through GNC-A.
- 5--Users will utilize McIDAS-V to display and interpret either real-time or archive JPSS imagery and products.

PROJECT ACCOMPLISHMENTS:

1--Participate in the bi-annual meeting in Barbados in May 2016 and quarterly virtual meetings of the WMO VLab Management Group, and CIRA participated in the eighth WMO VLab Management Group (VLMG-8) meeting on 9-13 May hosted by the Caribbean Institute for Meteorology and Hydrology (CIMH) in Barbados. Funding for travel to this meeting was provided by the CIMH project "Programmes for Building Regional Climate Capacity in the Caribbean (<http://rcc.cimh.edu.bb/>) and the SHyMet Training Grant.

The main items from the meeting were:

- VLab efficiency
- Satellite skills and knowledge for operational meteorologists
- Language translation of training resources
- Evaluation of training impact
- User readiness (particularly relevant for JPSS-1)
- Climate services
- Weather ready nations, a global training campus, and continuation projects and expansion over the coming year.



Figure 1. Participants attending the WMO VLab Management Group meeting at CIMH in Barbados during 9-13 May.

The motivation behind VLab activities is to build a strong training foundation to make it is easier to get messages, information, and data to the user. The meeting was well attended by 13 Centres of Excellence: Argentina, Australia, Barbados, Brazil, China (Beijing and Nanjing), Costa Rica, Kenya, Niger, Oman, Republic of Korea, Russian Federation, South Africa, and Morocco. Only one satellite operator was represented directly (EUMETSAT). NOAA was represented through its collaborator at CIRA; INPE and CONAE were represented through their CoE representatives. CIRA participated in virtual VLMG meetings on 20 September 2016 and 18 January 2017.

2--This project provides partial monetary support (2 months) for a WMO VLab Technical Support Officer (TSO), Luciane Veeck. Her efforts provide a very important stabilizing factor for the global coordination of training efforts under the umbrella of the WMO VLab. Member countries have access to her resources through the entire year. Luciane was also supported through CIRA under a WMO grant and another CIRA project during the past year. Highlights of her work that benefit the WMO community and the US include:

- Maintenance of the VLab central website and the VLab calendar of events <http://vlab.wmo.int>
- VLMG-8 meeting support (9-13 May 2016) – Coordination and organization of meeting logistics and agenda, collection of Satellite Operator and Centre of Excellence Status reports, analysis of reports, and participation in the meeting. Follow up activities included writing, reviewing and publishing the meeting summary report and tracking action items. The full report can be downloaded from the VLab website listed above under Publications/VLMG reports.
- WMO Education and Training (WMO-ETR) Online Course for Trainers 2016 – The WMO Online Course for Trainers of Regional Associations III (South America) and IV (North and Central America and the Caribbean) ran 29 March - 26 June 2016. In coordination with WMO ETR staff, other WMO trainers, and B. Connell, the TSO facilitated “Unit 11: Facilitated Learning”, and “Unit 12: Organizing and Delivering Training” during 13-30 June.
- CALMet Moodle Users Course Development – Collaboration occurred with the WMO ETR and with the Community for the Advancement of Learning in Meteorology (CALMet) throughout the past year to give continuation to the design of the Moodle course. Moodle is a free open source Course Management System (CMS). The course (Units 1, 2 and 3) was launched as part of CALMet Online 2016, with an online demo presentation on 27 September 2016.
- Climate Virtual Round Table (VRT) Global Event – Support for the organizing of the Climate VRT involved revision of slides, discussion of opportunities for engagement in online presentations, as well as the need for additional resources in easy to use formats.
- A VLab status report and presentation slides were prepared for the WMO 44th Plenary Session of the Coordinating Group for Meteorological Satellites (CGMS-44), which took place in Biot, France (6-10 June 2016). The full report can be downloaded from the VLab website listed above under Publications/Other reports. The slides were presented at CGMS-44 by Stephan Bojinski, the WMO Space Programme Representative.



--The revised Satellite Skills and Knowledge for Operational Meteorologists document was submitted to the WMO Commission for Basic Systems (CBS).

https://www.dropbox.com/s/j2fuwqk89ltu3at/SatESkills_V2.pdf?dl=0

--Coordination and collaboration efforts were directed towards developing a survey to determine the best training approaches to Red Green Blue (RGB) image creation and interpretation. EUMETSAT hosted the survey and VLMG members provided input and comments to the survey questions. All VLab members were given the opportunity to respond to the survey during the period 12 December 2016 to 8 January 2017.

3--Provide virtual JPSS imagery and product examples and partial support for monthly international virtual Regional Focus Group sessions.

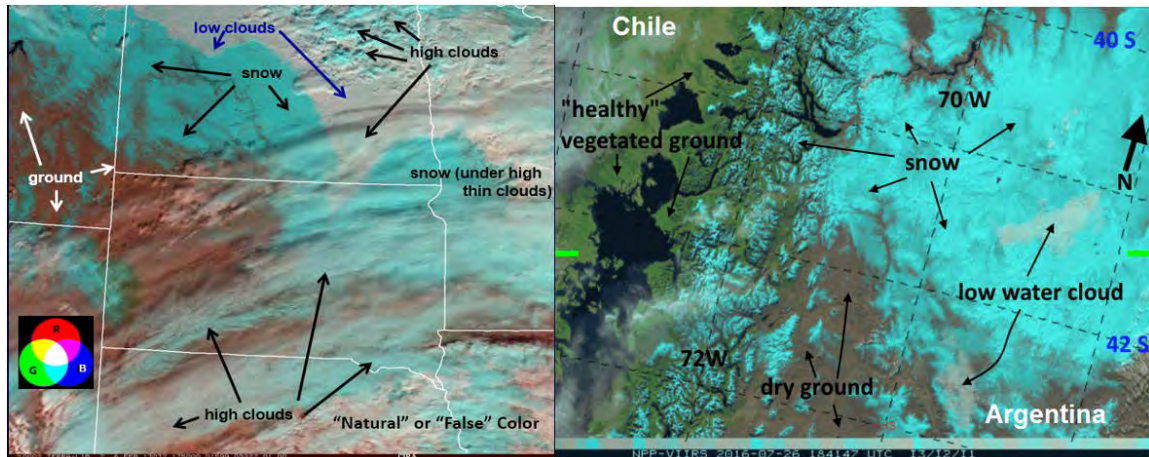

Figure 2. During the July session, an example of natural color RGB imagery (image on the left above) and the channels used to make it (not shown) were described. This was followed by a real time natural RGB image that was on RAMSDIS at the time (image on the right above). Labels have been added to distinguish features here.

-The WMO Virtual Laboratory Regional Focus Group of the Americas and Caribbean conducted 12 monthly bilingual (English/Spanish) weather briefings. The briefings made use of VISITview software to present GOES and POES satellite imagery from CIRA and GoToWebinar for voice communication over the Internet. Over the calendar year 2016, the participants from the U.S. included: CIRA, the NWS International Desk at NCEP/WPC, NWS/Office of the Chief Learning Officer (OCLO) Forecast Decision Training Division (FDTD), the NWS Training Center, the UCAR/JOSS-NWS International Activities Office, and UCAR/COMET. Thirty countries outside the US participated: Argentina, Bahamas, Barbados, Belize, Bolivia, Brazil, Cape Verde, Cayman Islands, China, Colombia, Costa Rica, Dominica, Ecuador, El Salvador, Germany, Guatemala, Haiti, Honduras, Mexico, Netherlands, Panamá, Paraguay, Peru, Russia, Slovakia, Spain, Suriname, Trinidad and Tobago, Uruguay, and United Kingdom. M. Davison and J. Galvez at the NCEP International Desks led the discussions (10 and 2 respectively). Participants offered comments and questions for their regions. The number of countries participating each month ranged between 7 and 18 (average 11); and the number of participants each month ranged between 8 and 48 (average 25).

The sessions were recorded and can be accessed here:

http://rammb.cira.colostate.edu/training/rmtc/fg_recording.asp

4--Participate in the GNC-A coordination group and evaluate JPSS/LEO products to be made available through GNC-A.

GEONETCast-Americas (GNC-A) is a great way to provide instructional material to users as well as provide products. It is a low cost alternative to many users in countries that still do not have adequate

internet access. It is also a good backup for emergency preparedness. The lower bandwidth capability prohibits sending level 1B type imagery, but potential products for users are those that are considered to meet the 9 GEO societal benefit areas.

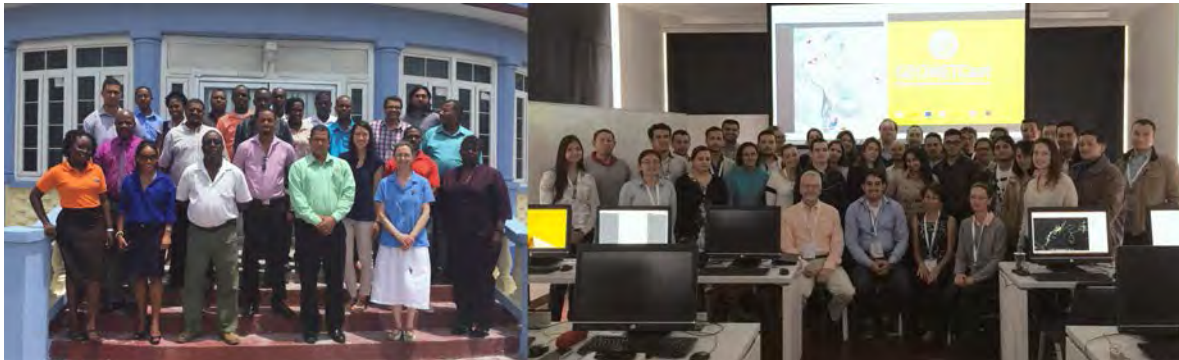

Figure 3. Participants attending the Satellite Data Training workshop at CIMH in Barbados during 3-6 May (left) and participants attending the AmeriGEOSS: GEONETCast workshop at Universidad Nacional de Colombia in Bogota Colombia during 7-10 June (right)

CIRA integrated GEONETCast Americas (GNC-A) product dissemination information into two workshops that occurred in May and June 2016. The 3-6 May workshop took place in Barbados at the Caribbean Institute of Meteorology and Hydrology and focused on building regional climate capacity in the Caribbean. This JPSS VLab project leveraged travel support from the CIMH project “Programmes for Building Regional Climate Capacity in the Caribbean (<http://rcc.cimh.edu.bb/>). CIRA and CIMH organized and delivered the “Satellite Data Training” workshop.

The 7-10 June workshop took place in Colombia at the National University in Bogota as part of the AmeriGEOSS activities for 2016. GEO-Colombia hosted the event. Funding for travel came from the CIRA SHyMet project.

The products of interest shared between the groups include precipitation estimation, vegetation health, and dust and ash detection. We used the opportunity to give a brief overview of Suomi-NPP to inform on the launch of JPSS-1 as well as encourage feedback from current and potential users on what JPSS products are desirable for the GNC-A broadcast.

5--Users will utilize McIDAS-V to display and interpret either real-time or archive JPSS imagery and products.

Updates and improvements were made to VIIRS related instruction materials and lab examples for access to imagery through NOAA CLASS. The data visualization tool is McIDAS-V. We were able to download and read NDVI data and incorporate this in the Colombia workshop in June (mentioned above). On a related note, INPE in Brazil has a direct receive antenna and has been creating a 10-day NDVI product for south America and sending it across GNC-A. We were able to load and display this data set in McIDAS-V as well.

Publications: None

Presentations:

Connell, B., 2016: New Satellite Sensors and capabilities: GOES-R and JPSS-1. Training Workshop on Satellite Data. Caribbean Institute for Meteorology and Hydrology, St. James, Barbados, 3-6 May. Presentation.

Connell, B., and R. Alfaro, 2016: Satellite overview: Current GOES vs GOES-R & current Polar products vs. next generation JPSS-1. GEONETCast Americas Workshop. Universidad Nacional de Colombia, Bogotá, Colombia, 7-10 June. Presentation.

Connell, B., D. Bikos, S. Lindstrom, E.J. Szoke, S. Bachmeier, J. Torres, E. Dagg, T. Mostek, B. Motta, M. Davison, and L. Veeck, 2016: Satellite User Readiness Through Training: VISIT, SHyMet, and WMO VLab. AMS 21st Satellite Meteorology Conference, Madison, WI, 15-19 August. Poster.

Connell, B. 2017: NOAA's Contributions to International Activities for Training in Satellite Meteorology via the WMO VLab. JPSS Science Seminar Series, 18 January. Virtual Presentation.

Connell, B., D. Bikos, S. Lindstrom, J. Torres, E. J. Szoke, E. L. Dagg, A. B. Schumacher, A. S. Bachmeier, A. Mostek, B. C. Motta, M. Davison, and L. Veeck, 2017: Satellite user readiness through training: VISIT, SHyMet, WMO VLab and liaisons. 13th Annual Symposium on New Generation Operational Environmental Satellite Systems, Seattle, WA, Amer. Meteor. Soc., 23-26 January.

Connell, B., L. Veeck, M. Davison, K.-A. Caesar, and V. Castro, 2017: The Impact of Regional Focus Group (RFG) Activities on the Use of Current Satellite Data and Images by Meteorological Personnel with Implications for New Satellite Use. 13th Annual Symposium on New Generation Operational Environmental Satellite Systems, Seattle, WA, Amer. Meteor. Soc., 23-26 January. Poster.

PROJECT TITLE: CIRA Support for the Organization of the 2016 Group for High Resolution Sea Surface Temperature (GHRSSST) XVII Meeting

PRINCIPAL INVESTIGATOR: Christian Kummerow

RESEARCH TEAM:

NOAA TECHNICAL CONTACT: Peter Minnett, U. of Miami – Chair of the GHRSSST Science Team.

NOAA RESEARCH TEAM: Ryan Wattam, Eileen Maturi and Paul DiGiacomo

FISCAL YEAR FUNDING: \$57,148

PROJECT OBJECTIVE:

Support GHRSSST, including travel support and logistics for the meeting to take place in Washington DC on 6-10 June 2016

PROJECT ACCOMPLISHMENTS:

The meeting was well attended. The introductory slide is shown below. The full meeting details can be viewed at:

<http://adf5c324e923ecfe4e0a6a79b2e2bae065313f2de67bbb078a3.r67.cf1.rackcdn.com/GHRSSST%20XVII/GHRSSST-XVII-agenda-v7-1.pdf>



GHR SST XVII
Washington DC, USA
6 – 10 June 2016

Draft Agenda v7 – 31st May 2016



Meeting hosted by:



in association with NOAA

PROJECT TITLE: CIRA Support to RAMMB Infrastructure for GOES-R Rebroadcast Data Collection at CIRA/CSU - EOY StAR Project

PRINCIPAL INVESTIGATOR: Renate Brummer and Michael Hiatt

RESEARCH TEAM: Renate Brummer, Michael Hiatt, Natalie Tourville

NOAA TECHNICAL CONTACT: Satya Kalluri (NOAA/NESDIS) and Candice Jongsma (NOAA/OAR)

NOAA RESEARCH TEAM: Don Hillger and Deb Molenaar (NESDIS/STAR/RAMMB)

FISCAL YEAR FUNDING: \$75,000 (FY15)

PROJECT OBJECTIVES:

CIRA had successfully requested previous NESDIS/StAR and GOES-R funding which paid for part of the cost for a new GOES-R Groundsystem Infrastructure (including multiple ingest server/processors, high-speed user storage devices, NAS storage devices). Colorado State University has provided matching funds for a 4.5 Meter S-Band Antenna and its installation next to the CIRA building in Fort Collins.

PROJECT ACCOMPLISHMENTS:

EOY StAR funds received in FY15 (with carry-over lasting into FY16) were used in FY16 to purchase the remaining parts needed to build a functioning short-term and long-term GOES-16 data archive. This archive consists of a high-performance 30-day NAS storage system (116TB) for all incoming GOES-16 data and two long-term standard NAS storage systems (96 TB each) for long-term GOES-16 data storage of selected data sets.

By the beginning of March 2017, CIRA successfully began to collect real-time data from the ABI. The data is being used by the CIRA GOES-R/GOES-16 teams to generate GOES-16 satellite imagery, GOES-16 derived products, to share GOES-16 products with operational forecasters, to post real-time imagery and products on CIRA's webpage and to store the imagery in a specially configured on-site long-term archive.

Publications: None

Presentations: None

PROJECT TITLE: CIRA Support for Research and Development for GOES-R Risk Reduction for Mesoscale Weather Analysis and Forecasting and Training

PRINCIPAL INVESTIGATOR: Steve Miller

RESEARCH TEAM: Dan Bikos, Renate Brummer, Cindy Combs, Bernie Connell, Robert DeMaria, Jack Dostalek, John Forsythe, Brody Fuchs, Hiro Gosden, Louie Grasso, John Haynes, Michael Hiatt, Scott Longmore, Kevin Micke, Kate Musgrave, Yoo-Jeong Noh, Karly Reimel, Matt Rogers, Steven Rutledge, Andrea Schumacher, Curtis Seaman, Natalie Tourville, Dave Watson.

NOAA TECHNICAL CONTACT: Satya Kalluri (NOAA/NESDIS) (NOAA/NESDIS)
and Steve Goodman (NOAA/NESDIS/GOESR Program Office))

NOAA RESEARCH TEAM: Don Hillger, John Knaff, Dan Lindsey, Deb Molenaar (all NESDIS/STAR)
and Mark DeMaria (NWS/NCEP/NHC)

FISCAL YEAR FUNDING: \$766,276

PROJECT OBJECTIVES:

The GOES-R era is part of a global observing system that includes polar-orbiting satellites with comparable spatial and spectral resolution instrumentation. The GOES-R/GOES-16 Advanced Baseline Imager (ABI) offers vastly improved spectral, spatial and temporal resolution relative to the current GOES I-P series satellites. The Geostationary Lightning Mapper (GLM), together with the ABI, also offer the potential to significantly improve the analysis and forecasts of mesoscale weather and natural hazards. GOES-R was successfully launched on Nov. 19, 2016, and was renamed to GOES-16 when it reached geostationary orbit a few weeks later. This annual report combines twelve CIRA research projects conducted in the areas of GOES-R Risk Reduction (R3). The overall goal of these science studies is to contribute to the reduction of time needed to fully utilize GOES-R/GOES16, provide the necessary proxy data to the algorithm groups for testing proposed algorithms and therefore to contribute to an improved algorithm selection and algorithm refinement, and –now with GOES-16 in orbit- to transition CIRA’s decision aid products to ABI.

CIRA’s GOES-R projects directly address NOAA’s Weather Ready Nation (WRN) objectives. The projects also fit under the Satellite Algorithm Development, Training and Education theme of CIRA’s Cooperative Agreement with NOAA.

This Annual Report covers twelve different projects which were part of the proposal titled “CIRA Support for Research and Development for GOES-R Risk Reduction for Mesoscale Weather Analysis and Forecasting and Training”:

Project 1--Diagnosis and Anticipation of Tropical Cyclone Behavior from New and Enhanced GOESR Capabilities. (third year project)

Project 2--Using total lightning data from GLM/GOES-R to improve real-time tropical cyclone genesis and intensity forecasts. (third year project)

Project 3--GOES-R ABI Multi-Spectral Imagery for Visibility Hazard Assessment via Himawari AHI. (second year project)

Project 4--Probabilistic Forecasting of Severe Convection through Data Fusion (*second year project*)

Project 5 --CIRA/CSU Participation in GOESR Post Launch Testing (*new project*)

Project 6 --CSU/Atmospheric Science Department Participation in GOESR Post Launch Testing (*new project*)

Project 7--GOES-R AWG Imagery Team (*continuation project*)

Project 8--GOES-R AWG Cloud Team (*continuation project*)

Project 9--CSU/Atmospheric Science Department Colorado Lightning Mapping Array / GLM Project
(continuation project)

Project 10--CIRA GOESR Ground System hardware support (*continuation project*)

Project 11--GOESR Program ADEB Senior Advisory Support (*continuation project*)

Project 12--GOESR/RAMMB Administrative Support (*continuation project*)

PROJECT ACCOMPLISHMENTS:

Project 1-- Diagnosis and Anticipation of Tropical Cyclone Behavior from New and Enhanced GOESR Capabilities.

The objectives of this Tropical Cyclone Behavior project were:

- 1--Interpretation of variations of cloud-top microphysics associated with TCs
- 2--Improve the statistical inference of TC structure from IR imagery
- 3--Methods to anticipate TC eye formation

1--Composites based on effective radius, despite variations in intensity and vertical wind shear, show a consistent and not unexpected signal showing that the smallest cloud-top effective radius composites have larger reflectivity throughout the atmosphere.

Further stratification of effective radius of intensifying (in the next 24h) and those that were in favorable environments for further intensification proved difficult to interpret.

CloudSat TC database was updated through 2016.

2--Finalized development of statistical relationships between the winds and the IR imagery. The 2014 version of HWRF was used to develop statistical relationships between the model winds and the synthetic imagery created as part of the post processing. There are both encouraging and discouraging results. Encouraging results: This method appears to fit the model wind fields quite well and may provide an outstanding method to produce a 3-D TC vortex for use in data assimilation (DA). The horizontal cross sections of wind structure produced by using observed IR imagery produce what appear to be realistic wind structures. Discouraging results: The size of hwrf storms is too large, thus this method produces structural features that are under less than rigorous inspection about a 1/3 too big. If scaling is applied these seem to be reasonable estimates of what nature is producing and may be useful for real-time assessment of TC structure (not model structure).

This method was presented at the International workshop on measuring high-wind speeds over the ocean (poster). Documentation of the method will likely occur in Year 3.

3--A statistical method to forecast eye formation probabilities has been developed and is currently running in real time on the TC-realtime web page. The results thus far have been encouraging. The documentation of the forecast algorithm development is well underway and should be submitted by April 2017.

Follow up on previous GOES-R funding:

A method to forecast wind radii and MSLP in the SHIPS model framework has been developed, has been run in real-time in 2016, and is slated to be transitioned to JTWC in June 2017. The method has been documented in Knaff et al. (2017)

Project 2--Using total lightning data from GLM/GOES-R to improve real-time tropical cyclone genesis and intensity forecasts.

The objectives of this project were:

- 1--Continue investigating ways to calibrate ENTLN and WWLLN lightning flash data
- 2--Test asymmetric WWLLN lightning predictors in the tropical cyclone rapid intensification index (RII)
- 3--Test WWLLN lightning predictors in the tropical cyclone genesis index (TCGI)

PROJECT ACCOMPLISHMENTS:

1--Spatial detection efficiency grids supplied by Dr. S. Rudlosky (NOAA/NESDIS) were used to calibrate both the WWLLN and ENTLN flash data from 2011-2014. A statistical comparison of WWLLN and ENTLN tropical cyclone-centered lightning predictors revealed that inner core ($r=0-200\text{km}$) and outer region ($r=200-400\text{km}$) azimuthal average flash density is very highly correlated (Pearson's correlation coefficient = 0.9). These results suggest that applications using longer-term azimuthal average lightning predictors will likely yield similar results regardless of whether WWLLN or ENTLN lightning data is used. Since the WWLLN data is available for a longer period of time (2005-present, versus 2011-present available from ENTLN), the remainder of the statistical research for this project has used WWLLN flash data.

2--Preliminary testing of storm motion-relative and 850-200mb shear-relative inner core and outer region lightning predictors helped us identify downshear-left average inner core lightning density as a predictor with the potential for improving the current lightning-based RII. However, further testing by replacing azimuthal average inner core lightning density with this asymmetric predictor resulted in a degradation of the skill of the lightning-based RII.

3--Azimuthal average lightning density from $r=0-200\text{km}$, $r=0-300\text{km}$, and $r=0-500\text{km}$ were tested as potential predictors in a statistical tropical cyclone formation product, the TC genesis index (TCGI). Although preliminary testing found a potential statistical relationship between increased $r=0-500\text{km}$ azimuthal average lightning density and TC formation, lightning density was not found to be a statistically significant predictors during TCGI development.

Project 3--GOES-R ABI Multi-Spectral Imagery for Visibility Hazard Assessment via Himawari AHI.

This project develops multi-spectral lofted dust, snow cover, and blended imagery products tailored to the GOES-R Advanced Baseline Imager (ABI), using the Advanced Himawari Imager (AHI) as a material test bed. These value-added applications translate complex/ambiguous scenes into visually intuitive graphical depictions that enhance the target parameter while preserving the meteorological context and full spatial resolution of the sensor. They bear direct relevance to the challenges of visibility hazard forecasting and both complement and augment high-priority baseline products. The applications realize the promise of 10+ years of research and development on the polar-orbiting satellite constellation (including the MODerate-resolution Imaging Spectroradiometer [MODIS] sensors on Terra and Aqua, and the Visible/Infrared Imaging Radiometer Suite [VIIRS] on the Suomi National Polar-orbiting Partnership satellite). Demonstrated to National Weather Service (NWS) forecasters in AWIPS via the GOES-R Satellite Proving Ground (PG; Goodman et al., 2012), these applications exemplify the power of multi-spectral imagery for scene characterization, albeit at the sampling limitations of the polar-orbiting platform. The new algorithms will require some modification to account for differences in the response functions of AHI/ABI vs. the heritage polar-orbiting sensors. Anticipated availability of GOES-R ABI in

year 2 of this project (2QFY2016) will enable software transition and direct comparisons between the AHI and ABI.

CIRA has been acquiring Himawari-8 AHI data from the NOAA/NESDIS/STAR data feed since July 2015, and a suite of AHI imagery products have been developed and are produced in real time. A webpage dedicated to real time AHI imagery products has been added to CIRA's RAMSDIS Online website (<http://rammb.cira.colostate.edu/ramsd/online/himawari-8.asp>) and has quickly become a very popular page on the website. Requests for imagery products and sectors have come from wide variety of users, including: NWS (Alaska Region, Pacific Region, AWC and OPC/WPC), the Anchorage Volcanic Ash Advisory Center (VAAC), as well as international users from Australia, Japan, the Philippines, portions of southeast Asia, Indonesia, and even Europe.

PROJECT ACCOMPLISHMENTS:

1--We continue to produce many multispectral imagery products from AHI in realtime, including Hybrid Atmospherically Corrected (HAC) True Color/Geocolor, Natural Color RGB, Airmass RGB, Dust RGB, Fire Temperature RGB, two Ash RGBs, and the "split window difference" (useful for dust and ash). These are made available on our RAMSDIS Online website linked above. Geocolor and the Airmass RGB are distributed via AWIPS and heavily used by forecasters at the Aviation Weather Center, Ocean Prediction Center and Weather Prediction Center (Figure 1).

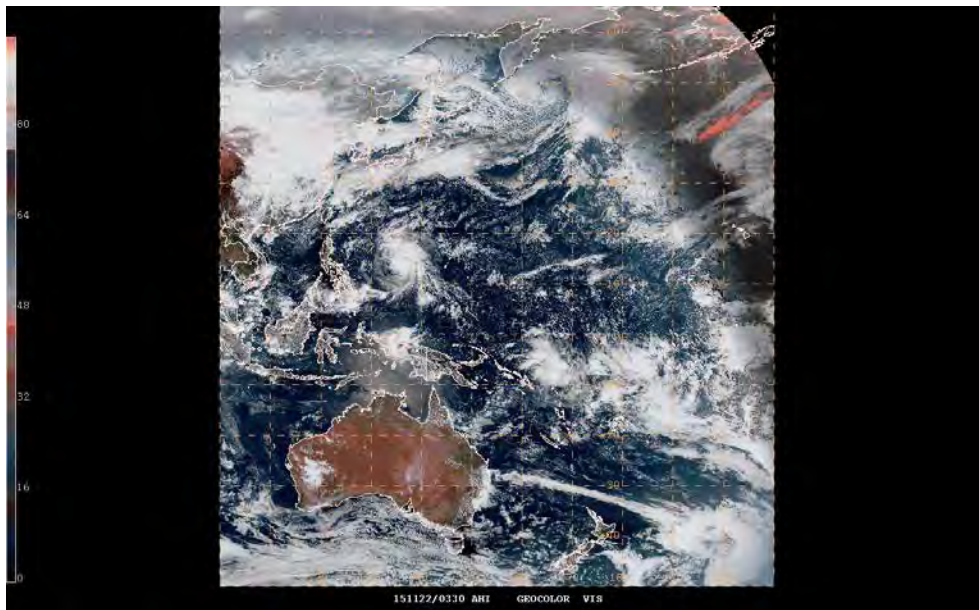

Figure 1. Screen capture of CIRA's Geocolor product from Himawari as viewed in NAWIPS, the operational display software used by the NWS Ocean Prediction Center.

During the past year, new sectors and new products have been added. We now produce imagery from all 16 AHI bands for the China sector, per a request from NWS Pacific Region ESSD Chief Bill Ward. The Natural Color RGB, Airmass RGB and Geocolor products are now available for the rapid scan (2.5 min) floating sector. Additional sectors have been added for Southeast Asia, Marshall Islands, Bangladesh, the Philippines, and a broad scale "South Pacific Islands" sector covering the region from American Samoa to the Solomon Islands (Figure 2).

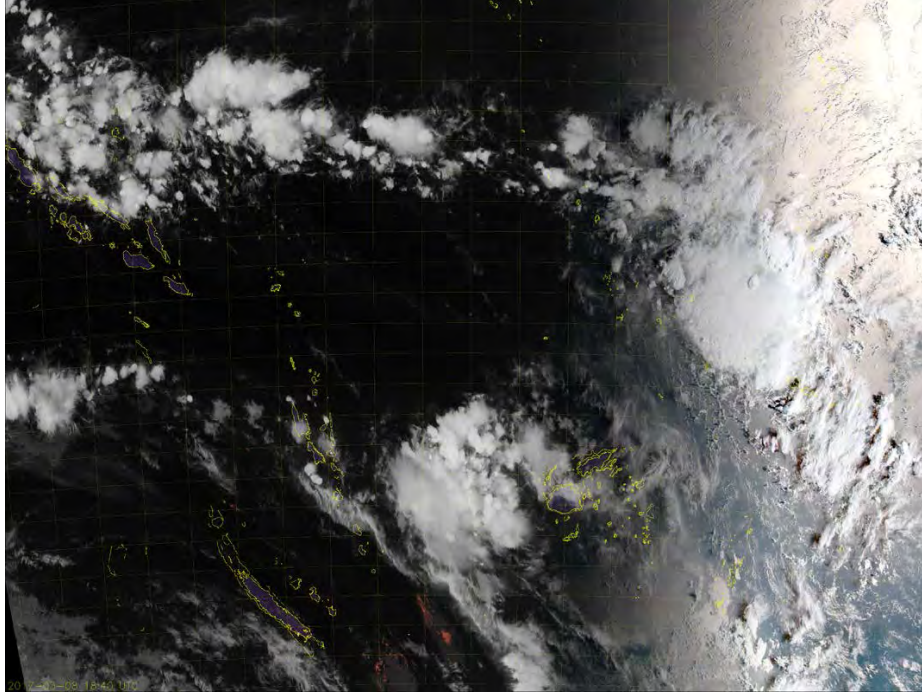

Figure 2. Example AHI Geocolor image of the South Pacific Islands sector at sunrise over Fiji (18:40 UTC 8 March 2017).

2--Development of the AHI Dynamic Enhancement Background Reduction Algorithm (DEBRA) dust detection algorithm is nearly complete and will be made available on RAMSDIS Online shortly. An example of an AHI DEBRA dust case over north-eastern China can be seen in Figure 3 below.

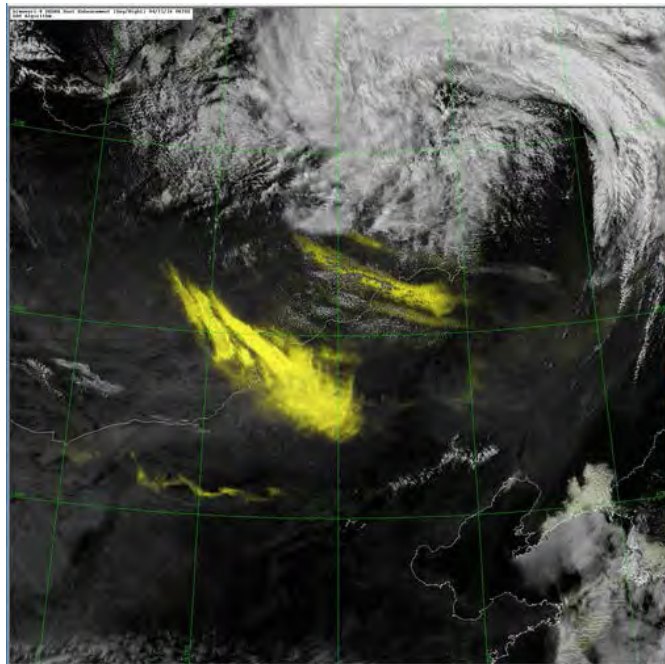

Figure 3. AHI DEBRA dust detection over north-eastern China on 21 April 2016.

3--With the successful launch of GOES-R (GOES-16), work has begun to transition these multispectral products from AHI to ABI. Synthetic HAC (SHAC) True Color from ABI (see description under Project 7 – GOES-R AWG Imagery Team) was used as the “first light” image distributed in the first press release made by the GOES-R Program Office (Figure 4) and was shown by numerous media outlets and nearly every GOES-R related talk at the AMS Annual Meeting in January 2017. SHAC True Color and Geocolor are now running in realtime, although this data will not be made publicly available until the ABI has reached “provisional” maturity status.

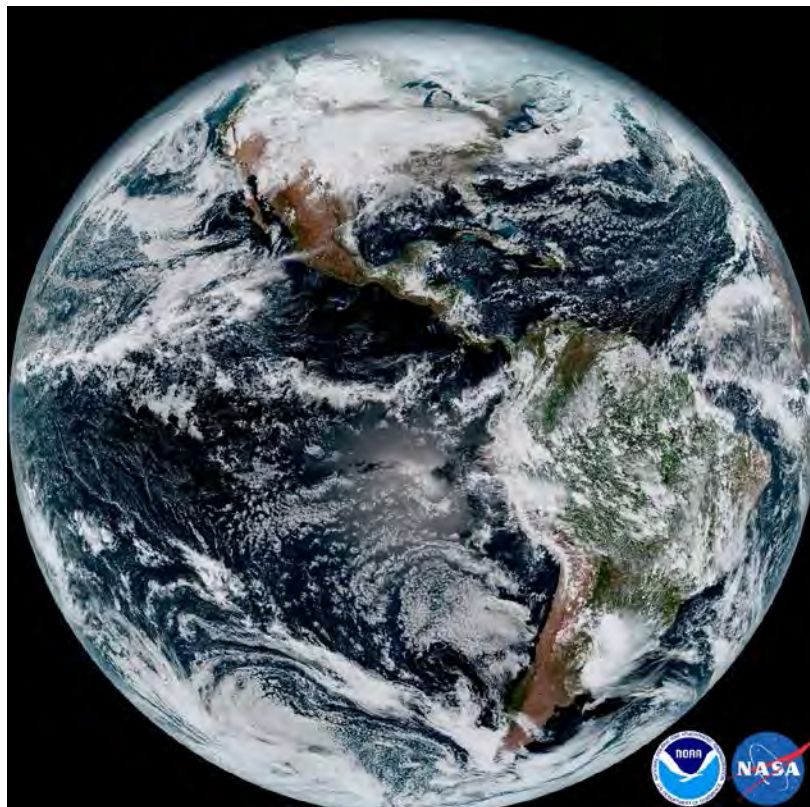

Figure 4. The first SHAC True Color image produced from ABI data (15 January 2017). This image was part of the initial GOES-R press release, and was featured on numerous media outlets including the Weather Channel, CNN and the Washington Post.

Work has also begun on the ABI transition of other CIRA RGB composites currently produced for AHI.

4--We maintain the “Himawari Loop of the Day” website (http://rammb.cira.colostate.edu/ramsdisk/online/loop_of_the_day/himawari.asp), which highlights interesting applications of AHI imagery - including the multispectral applications developed under this project. A compilation of the “Top 10 Himawari Loops of the Day” has been very popular with site visitors. With ABI data now available, a new GOES-16 Loop of the Day website was turned on beginning 2 March 2017. This page may be viewed at http://rammb.cira.colostate.edu/ramsdisk/online/loop_of_the_day/. These “Loop of the Day” websites are a valuable training resource and help introduce users to the variety of AHI and ABI applications.

Project 4 -- Probabilistic Forecasting of Severe Convection through Data Fusion

This CIMSS-CIRA collaboration project builds upon recent research in the field of severe convective forecasting, by incorporating the University of Wisconsin Cloud-Top Cooling concept, GOES-derived cloud-top properties, Multi-Radar Multi-Sensor derived products, and high-resolution NWP-derived fields.

PROJECT ACCOMPLISHMENTS:

ProbSevere, a real-time statistical model developed at CIMSS/Univ. of Wisconsin, uses information from a variety of sources to predict the probability that individual storms will produce severe weather. Feedback on the model has been overwhelmingly positive from the National Weather Service. Forecasters have also requested that the model predict individual severe storm hazards for hail, wind, and tornadoes. CIRA's primary task in the project has been to assist in the development of near storm environment predictors for hail. To accomplish this, data from the Rapid Refresh numerical model was archived and analyzed, along with the other data collected at CIMSS. A version of the ProbSevere model to be run locally at CIRA was developed, and it is being used to help determine and test the near storm environment predictors for large hail. This information has been provided back to the model's primary developers at CIMSS.

Project 5--CIRA/CSU Participation in GOESR Post Launch Testing

This PLT project focusses on a Colorado Front Range / High Plains study in support of GOES-R Post Launch Testing (PLT). The challenging and unique aspects of convection (both isolated and organized) over this region in terms of i) unique storm morphology, ii) production of large, damaging hail, iii) unique cloud-top microphysical properties, iv) extreme lightning flash rates, v) propensity for inverted charge structures, and vi) evolution of unorganized late afternoon convection into nocturnal mesoscale convective systems (MCS) make a strong case for examining ABI/GLM performance.

PROJECT ACCOMPLISHMENTS:

The Geostationary Lightning Mapper (GLM) aboard the GOES-16 satellite will begin sending data in March 2017. CIRA's project in the post-launch test is to compare the GLM data to both ground-based and space-based data in order to help in its verification. The ground-based data comes from the Colorado Lightning Mapping Array (COLMA), and this portion is being completed in collaboration with Prof. Steve Rutledge and his group at Colorado State University. A real time data feed from COLMA has been established to CIRA and is ready to go. The additional space-based data used in the project comes from GOES-16's Advanced Baseline Imager (ABI). Over the first 3 months of 2017, readers for ABI data have been written and are also now in place for the arrival of the GLM data. We expect that data to begin flowing very soon, at which time the verification work will commence.

Project 6 -CSU/Atmospheric Science Department Participation in GOESR Post Launch Testing

Project 6 is the contribution of Prof. Steven Rutledge's team (CSU/Atmospheric Science Department) to the GOESR Post Launch Testing project.

PROJECT ACCOMPLISHMENTS:

This award provided support for personnel from the CSU Radar Meteorology Group to participate in the GOES-R PLT project. At the time of this Annual Report, GOES-16 Geostationary Lightning Mapper (GLM) data has not been available yet to conduct any GLM PLT research. CSU personnel have participated in the planning of the Cal/Val field campaign, including S. A. Rutledge who has been involved in planning via several telecons. CSU is prepared to support one flight of the ER-2 research aircraft, which will take place if favorable weather is present over northeast CO during the ER-2 westward ferry back to Palmdale,

CA. The CSU-CHILL radar will be operated under this support as well. We hope to collect data in a High Plains supercell storm, particularly one that is characterized by high flash rates and an inverted charge structure. Of interest in this data collection will be to compare lightning flash rates from GLM to flash rates derived from COLMA. CSU-CHILL radar data on storm structure and intensity will be analyzed in concert with the ABI data to link cloud top signatures from ABI to hail formation, etc.

Project 7--GOES-R AWG Imagery Team

The GOESR AWG Imagery Team project involved the development of Rayleigh-corrected look-up tables for producing an ABI Synthetic Green Band, thereby enabling production of GOES-R True Color imagery.

The CIRA team used Himawari-8 AHI data to produce the required look-up tables enabling translation to ABI. The green band resident on AHI was used as a source of both training and validation development of a synthetic green band. CIRA AWG Visualization Team members collaborated with NOAA-NESDIS and UW-CIMSS colleagues to support this development and evaluation through the delivery of AHI data, both post-launch test data and real-time data stream.

PROJECT ACCOMPLISHMENTS:

--We have developed the Hybrid, Atmospherically Corrected (HAC) True Color algorithm for Himawari-8 AHI. This algorithm produces improved True Color imagery using a correction for Rayleigh scattering and the "hybrid green" approach that combines bands 2 and 4 to improve the appearance of land surfaces. A paper discussing this algorithm was published in BAMS and was featured on the cover of the October 2016 issue (Figure 5).



Figure 5. The cover of the October 2016 issue of BAMS highlighting our HAC True Color algorithm.

--HAC True Color imagery is now the daytime component of CIRA's Geocolor product, which is produced in real-time on the RAMSDIS Online website. AHI Geocolor is also distributed to forecasters via AWIPS and has become a popular product at the Aviation Weather Center (AWC) and Ocean Prediction Center (OPC) of the National Weather Service.

--Work continues on development of the Synthetic Hybrid, Atmospherically Corrected (SHAC) True Color for GOES-R ABI. This algorithm uses information from the blue, red and near-IR vegetation bands to predict the reflectance in the green visible band, and was trained on Himawari-8 AHI data. Rayleigh-correction and the "hybrid green" approach are then applied to create synthetic True Color imagery for GOES-16, which is lacking the green-wavelength visible band. While not complete, the early attempts to produce synthetic True Color imagery from GOES-16 have been a success. An example of CIRA's SHAC True Color Imagery from ABI can be seen in Figure 4 (Project 3) and below in Figure 6.

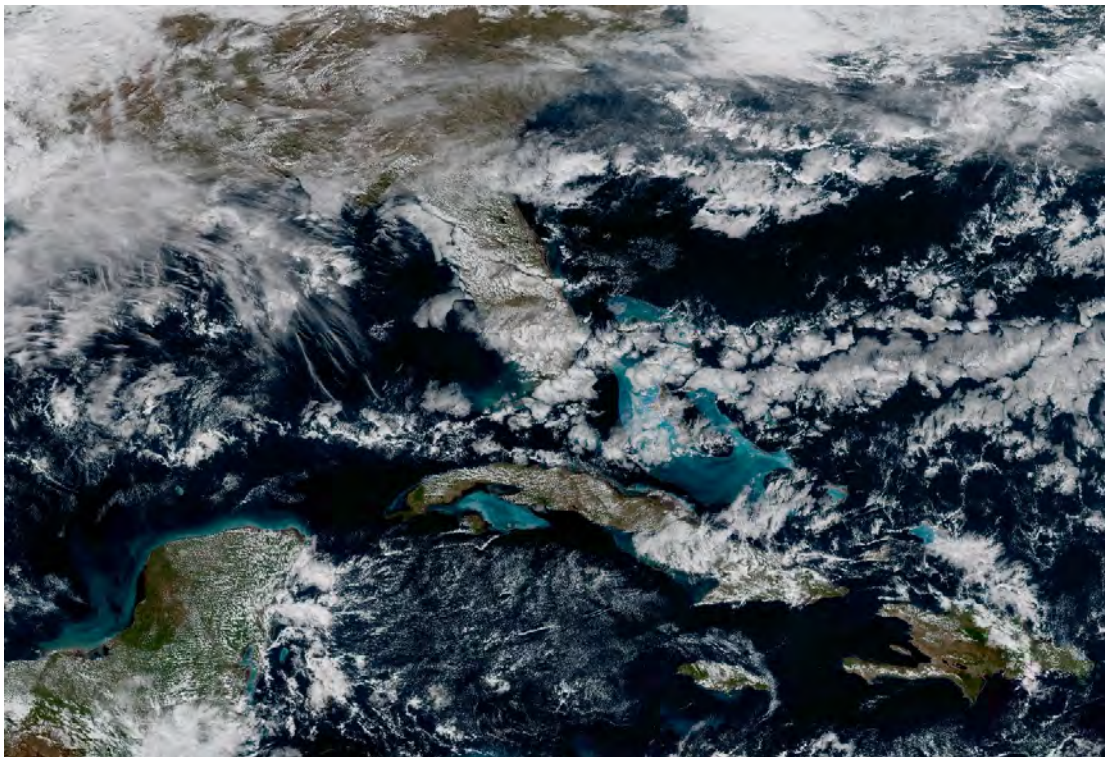

Figure 6. CIRA SHAC True Color image produced from ABI data (15 January 2017 at 1807 UTC).

IRA's "first light" SHAC True Color images from ABI were shown by many media outlets and in nearly every ABI-related talk presented at the 2017 AMS Annual Meeting. SHAC True Color imagery from CIRA were also used in the first official ABI press release from the GOES-R Program Office. The list of media outlets to show CIRA-produced SHAC True Color imagery from GOES-16 includes CNN, CBS News, The Weather Channel, The Washington Post, and The Today Show (Figure 7).



Figure 7. Al Roker of The Today Show discussing the “first light” ABI true color imagery on air (16 January 2017).

Project 8--GOES-R AWG Cloud Team

This project is a collaborative work between Andrew Heidinger of NOAA/NESDIS/STAR/ASPB and his colleagues at the Cooperative Institute for Meteorological Satellite Studies (CIMSS) and the Cooperative Institute for Research in the Atmosphere (CIARA) led by Steve Miller. On behalf of the GOES-R Cloud Application Team, we will generate a cloud geometric thickness product (CGT) applicable to the Advanced Baseline Imager (ABI). This product can be combined with cloud top height (CTH) to infer a cloud base height (CBH) for the topmost cloud layer, and further aggregated to provide an enhanced cloud cover-layers (CCL) product that accounts for the vertical extent of clouds. Our aim is to begin developing and optimizing these products, and ultimately deliver working versions of the scientific code to the Algorithm Working Group (AWG) Algorithm Integration Team for operational code translation and integration.

The specific work entails translation to the geostationary platform of an algorithm originally developed for the polar-orbiting Suomi National Polar-orbiting Partnership (S-NPP) Visible Infrared Imaging Radiometer Suite (VIIRS) sensor. First we will apply an existing version of the algorithm to Himawari-8 Advanced Himawari Imager (AHI), as a way of evaluating the performance in advance of GOES-R ABI. Then, when ABI data become available, we will evaluate algorithm performance on this new sensor. Given the timeframe of ABI launch and first light data availability, we anticipate that these comparisons will be conducted toward the end of the current funding period. Because the CGT, CBH, and CCL products require upstream products as input, the timing of our evaluations for GOES-R are contingent upon the availability of those other products. By working within the framework of the NOAA Clouds from AVHRR Extended (CLAVR-x) processing system, in collaboration with Andrew Heidinger and his development team, we anticipate that these upstream inputs will be available during the Post Launch Test (PLT) and Post Launch Test Product Testing (PLPT) period.

The CIARA Cloud Team focused on the following tasks:

- 1-- Continue development of CBH/CGT integrated within the CLAVR-x system
- 2-- Configure CGT algorithm to work on AHI data stream

3-- Conduct matchups to CloudSat/CALIPSO and preliminary evaluation of AHI performance to prepare for application of algorithm to GOES-R ABI

PROJECT ACCOMPLISHMENTS:

1-- As part of the JPSS Cloud Cal/Val efforts, the CIRA team has developed a new statistical CBH/CGT algorithm based on A-Tran satellite data and successfully implemented in the CLAVR-x system in collaboration with CIMSS colleagues. The current algorithm is now being tested by the NESDIS/STAR Algorithm Scientific Software Integration and System Transition Team (ASSISTT) in the operational environment. A few updates for further algorithm refinements have been implemented, including error flags and cloud base for deep convective clouds. An evaluation of this algorithm and comparison with the original CBH/CGT algorithm produced by the JPSS program have been published.

2-- We have applied the new CBH/CGT algorithm to AHI data and are in the process of evaluating the performance in advance of GOES-R ABI data. The AHI original data was converted to the NetCDF format which can be ingested into the current CLAVR-x system, with support from the CIMSS team. The cloud properties including CTH, CBH, and CGT were retrieved in CLAVR-x for AHI cases (Figure 8), and results have been examined. As GOES-R (now GOES-16) was successfully launched on 19 November 2016, we will become involved in the PLT phase of the GOES-R program, which includes reconfiguring our code to work with the GOES-R data stream.

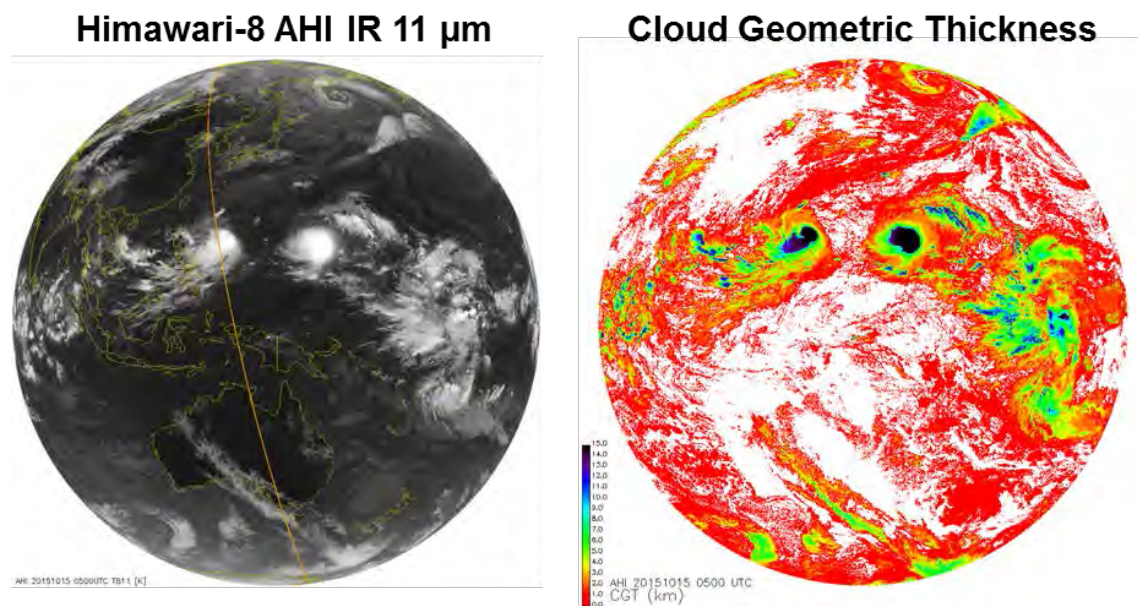

Figure 8. Himawari-8 AHI IR image (left) and cloud geometric thickness (right) at 0500 UTC on 15 October 2015. The CloudSat overpass is indicated with the orange line in the left panel.

3-- We evaluate the performance on AHI with the same strategies adopted for evaluation of the S-NPP VIIRS CBH algorithm using CloudSat matchups. The CGT information from the CBH algorithm is used to improve the CCL product. We developed a beta version of the new CCL algorithm to provide lower-level cloud coverage information. The new CCL algorithm was applied to Himawari-8 AHI for case study evaluations using CloudSat data. Figure 9 below presents an example of the new cloud layer product with the additional Low+Mid, Mid+High, and Low+Mid+High flags applied to the AHI case shown in Figure 8. The vertical cross-section of CloudSat data is shown in the 3-D view for comparison against the AHI retrieval. As shown in the figure, the algorithm can provide the additional information on the presence of lower cloud layers around deep convective clouds of cyclones which are missed by the previous CCL algorithm based on the cloud top data only (Low, Mid, and High flags).

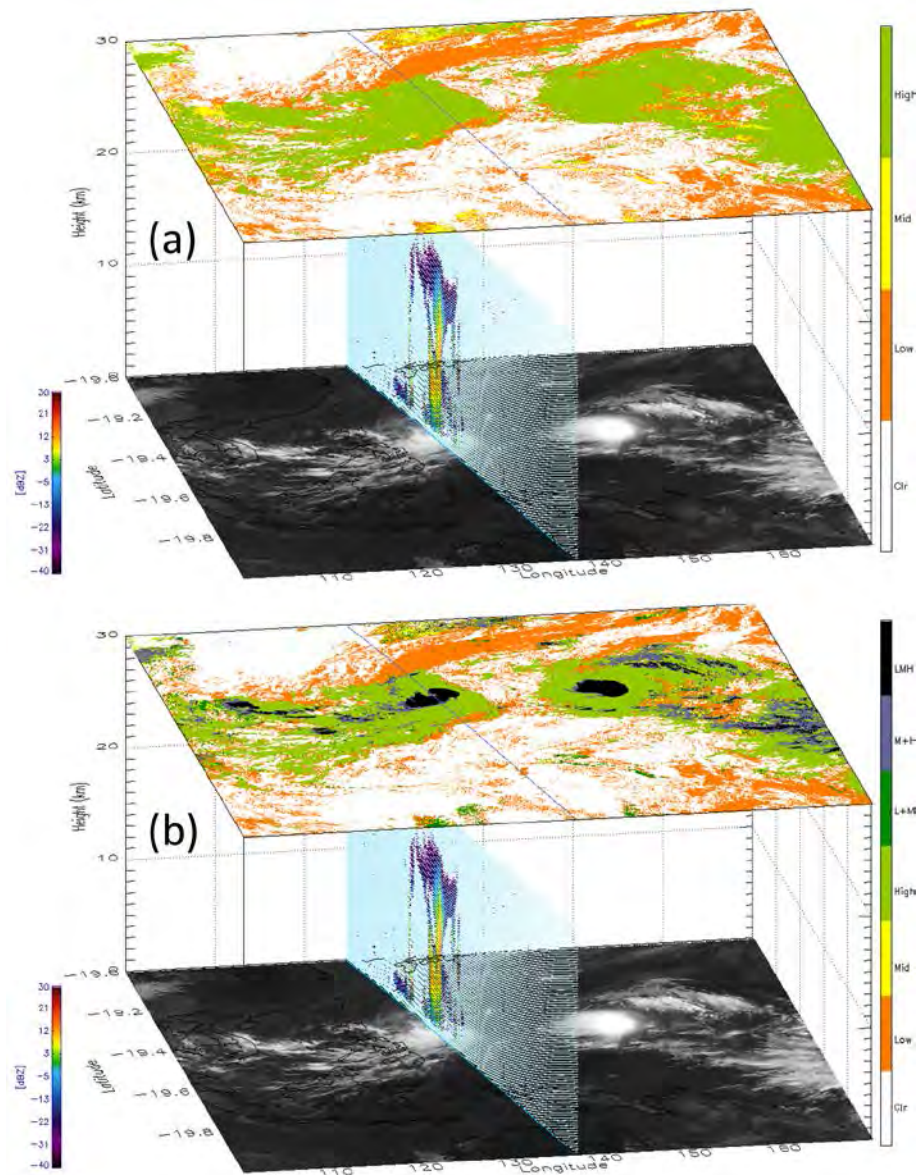

Figure 9. Improvement of Himawari-8 AHI Cloud Cover/Layer (CCL) products by using cloud geometric thickness information: (a) the original CCL (Low, Mid, and High flags) and (b) the new CCL with three additional cloud layer flags (Low+Mid, Mid+High, and Low+Mid+High) at 0500 UTC on 15 October 2015 over the Pacific Ocean. The vertical cross-section of CloudSat reflectivity data is shown across the AHI 11- μ m IR image in the 3-D view for comparison against the AHI retrieval.

Project 9--CSU/Atmospheric Science Department Colorado Lightning Mapping Array/GLM Project

With the successful launch of GOES-R/GOES-16 carrying the Geostationary Lightning Mapper (GLM), many new opportunities for nowcasting severe weather utilizing GLM lightning observations were established. For example, NWS offices can now further integrate lightning data into their warning decision process. Before such applications can achieve their full potential, it is important to validate the GLM observations against other lightning measurements. Equally important is the conduct of studies

documenting GLM lightning flash rate behavior to observed changes in convective storm behavior, including evolution of radar echo patterns. Steve Rutledge's CSU Atmospheric Science team is taking part in both of these activities.

PROJECT ACCOMPLISHMENTS:

During the past year, Karly Reimel has made excellent progress on her M.S. thesis research. Her work is aimed at identifying the role of real time lightning observations in helping to improve the forecast lead times for non-supercell and supercell tornadoes. She has carried out detailed radar and lightning analyses for two landspout and two supercell cases within the confines of the COLMA. CSU-CHILL and NEXRAD data have also been utilized in this study. As consistent with previous work, lightning clearly marks the updraft phase ahead of non-supercell tornado formation, where it is hypothesized that pre-existing vorticity such as a convergence boundary or gust front is tilted into the vertical by actions of the storm updraft. Lightning flash rates clearly peak just prior to the landspout and decrease quickly associated with dissipation of the landspout. Essentially the behavior in lightning is dictated by the storm updraft. The supercell cases both show a decrease in lightning just prior to the tornado or coincident with the tornado. We hypothesize that decreasing flash rates may be associated with intensification of the rear flank downdraft that is a source of low level vorticity. We have also shown a link between the height of the peak LMA sources to storm intensity for both non-supercell and supercell tornadoes.

The COLMA has also been maintained by this grant support. Currently all stations are on line and working well in advance of the upcoming GLM Cal/Val project. Personnel from NMIMT recently visited several COLMA stations to replace hardware and assure they are ready for this spring's field program. COLMA data continues to be used in the DEN and CYS NWS Offices.

Project 10--CIRA GOESR Ground System hardware support

CIRA had successfully requested previous NESDIS/StAR and GOES-R Groundsystem funding which paid for part of the cost for a new GOES-R Groundsystem Infrastructure (including multiple ingest server/processors, high-speed user storage devices, standard NAS storage devices). Colorado State University has provided matching funds for a 4.5 Meter S-Band Antenna and its installation next to the CIRA building in Fort Collins.

PROJECT ACCOMPLISHMENTS:

This GOES-R Groundsystem project requested funds for CIRA to purchase the necessary GOES-R ingest servers which run the open source software called Community Satellite Processing Package (CSPP). The CSPP software handles ingesting and processing the satellite data feed received from the GOES-R antenna system. The University of Wisconsin Madison Space Science and Engineering Center (SSEC) has designed a special GOES-R CSPP device called a SSEC Data Ingestor (SDI) Appliance. The SDI appliance is a complete solution for processing the GOES-R GRB data stream and further enhanced over standard CSPP solutions by providing highly reliable customized hardware and McIDAS ADDE compatibility. With this GOES-R Groundsystem funding CIRA purchased two SDI GRB appliance hardware pieces and the SSEC ingest software from SSEC/Wisconsin. CIRA also purchased the SDI GRB Support, ADDE Option. The ADDE option includes McIDAS ADDE access, and all software and system updates for 1 year. The set-up of the SDI GRB Appliance hardware at CIRA was successfully carried out by CIRA's Primary Ground Station Engineer. Starting in March 2017, CIRA began to collect real-time data from the GOES-16 ABI.

Project 11--GOESR Program ADEB Senior Advisory Support.

Professor Tom Vonder Haar, Member of the National Academy of Engineering, continues to serve on the Independent Advisory Committee (IAC) for GOES-R. The IAC reports directly to the GOES-R SDEB. It supports tasks assigned to them and by the GOES-R Program Scientist, Dr. Steve Goodman. The range

of advisory tasks include all aspects of the Program such as algorithm development and testing; Instrument and Product Cal/Val both before and after launch; User preparation and outreach; Science and operational applications; and combined products from GOES and JPSS.

PROJECT ACCOMPLISHMENTS:

During this reporting period, Professor Vonder Haar supported the GOES-R Program as an ADEB Advisor at discussions in Fort Collins, CO. He also attended the 2017 AMS Annual Meeting in Seattle where he attended GOES-R presentations and poster sessions. Professor Vonder Haar also reviewed the “first look” data from ABI as it was studied and processed by CIRA’s GOES-R Team.

Project 12--GOESR/RAMMB Administrative Support

Consistent with our long-standing Memorandum of Understanding between NOAA and Colorado State University, the CIRA GOES-R project includes a budget specifically to support administrative and clerical personnel directly associated with the technical and managerial administration of this project. This support is “quid pro quo” for the reduced indirect cost rate agreed upon in the long-standing subject memoranda. Kathy Fryer will provide communication support, assist in the acquisition and distribution of reference materials relevant to the conception and execution of the project, collection of reports and conference papers. In addition, CIRA also provides some administrative support for the wider GOES-R program, including tracking of project progress reports. CIRA also provides federal travel documentation and makes all of the travel arrangements for the Federal RAMMB Employees.

Publications:

Albrecht, R., S. Goodman, D. Buechler, R. Blakeslee, and H. Christian, 2016: Where are the lightning hotspots on Earth? *Bull. Amer. Meteor. Soc.*, 97(11). doi:10.1175/BAMS-D-14-00193.1, NOTE: BAMS Cover Image by Steve Miller

Knaff, J. A., C. R. Sampson, and G. Chirokova, 2017: A Global Statistical-Dynamical Tropical Cyclone Wind Radii Forecast Scheme. *Wea. Forecasting*. DOI: <http://dx.doi.org/10.1175/WAF-D-16-0168.1>

Knaff, J.A., C.J. Slocum, K.D. Musgrave, C.R. Sampson, and B. Strahl: 2016: Using routinely available information to estimate tropical cyclone wind structure. *Mon. Wea. Rev.*, 144, 1233-1247, doi:10.1175/MWR-D-15-0267.1

Line, W., T. J. Schmit, D. Lindsey, and S. Goodman, 2016: Use of Geostationary Super Rapid Scan Satellite Imagery by the Storm Prediction Center. *Weather and Forecasting*, 31, 483-494, doi:10.1175/WAF-D-15-0135.1.

Miller, S. D., T.J. Schmit, C. Seaman, D. Lindsey, M. Gunshor, R. Kors, Y. Sumida, and D. Hillger, 2016: A Sight for Sore Eyes: The Return of True Color Imagery to Geostationary Satellites. *Bull. Amer. Meteor. Soc.*, 97(10), 1803-1816, doi:10.1175/BAMS-D-15-00154.1
NOTE: BAMS Cover Article

Noh, Y. J., J. M. Forsythe, S. D. Miller, C. J. Seaman, Y. Li, A. K. Heidinger, D. T. Lindsey, M. A. Rogers, and P. T. Partain, 2017: Cloud base height estimation from VIIRS. Part II: A statistical algorithm based on A-Train satellite data. *J. Atmos. Ocean. Tech.*, doi: 10.1175/JTECH-D-16-0110.1.one.

Seaman, C. J., Y. J. Noh, S. D. Miller, A. K. Heidinger, and D. T. Lindsey, 2017: Cloud base height estimation from VIIRS. Part I: Operational algorithm validation against CloudSat. *J. Atmos. Ocean. Tech.*, doi: 10.1175/JTECH-D-16-0109.1.

Presentations:

Brummer, R., S. D. Miller, D. Lindsey, C. Seaman, E. Szoke, A. Schumacher, and J. Torres, 2016: GOES-R and JPSS Satellite Proving Ground Activities at CIRA (poster). 2016 EUMETSAT Meteorological Satellite Conference, Darmstadt, Germany, 26-30 September 2016.

Lindsey, D.: Himawari-8: Improvements in Temporal and Spatial resolution, and development of True Color Imagery. COMET AHI User Training Workshop, Boulder, CO, 14 November 2016. Invited oral presentation.

Lindsey, D.: Himawari-8 - Using New Spectral Bands for Meteorological Applications. COMET AHI User Training Workshop, Boulder, CO, 14 November 2016. Invited oral presentation.

Lindsey, D.: Himawari and GOES-R: Ushering in a New Generation of Geostationary Satellites. Metro State University, Denver, CO, 15 November 2016. Invited guest class lecture.

Miller, S. D., 2016: Himawari-8. Science presentation for visitors of Chengdu University of Information Technology, China. Meeting held at CSU, Lory Student Center, Fort Collins, CO, July 2016.

Miller, S.D., 2016: Satellite Research and Application Development at CIRA. NOAA/NESDIS CoRP Science Symposium, CIRA Science Project Overview. CIRA Executive Board Meeting, Fort Collins, CO, May 2016.

Miller, S., T. Schmit, C. Seaman, M. Gunshor, D. Lindsey, D. Hillger and Y. Sumida, 2016: Himawari-8 AHI Lays a Foundation for True Color Capabilities on GOES-R ABI. 2016 Proving Ground User Readiness Meeting, Norman, OK, 10 May 2016. Oral presentation.

Miller, S. D., D. T. Lindsey, C. J. Seaman, T. J. Schmit, M. M. Gunshor, D. W. Hillger, Y. Sumida, 2016: Himawari-8 AHI Proves "Instrumental" in Preparations for Enhanced GOES-R ABI Imagery Applications. Joint 21st AMS Satellite Meteorology, Oceanography, and Climatology Conference, Madison, WI, 15-18 August, 2016.

Miller, S. D., D. Lindsey, C. Seaman, T. Schmit, M. Gunshor, D. Hillger and Y. Sumida: Anticipating GOES-R ABI Multi-spectral Imagery Capabilities via Himawari-8 AHI. 2016 EUMETSAT Meteorological Satellite Conference, Darmstadt, Germany, 26-30 September 2016. Oral presentation.

Noh, Y. J., S. D. Miller, J. M. Forsythe, C. J. Seaman, D. T. Lindsey, A. K. Heidinger, and Y. Li, 2016: The newly operational VIIRS Cloud Base and CCL (Cloud Cover/Layers). STAR JPSS Annual Science Team Meeting, College Park, MD, 8-12 August 2016.

Noh, Y. J., S. D. Miller, C. J. Seaman, J. M. Forsythe, R. Brummer, D. T. Lindsey, A. Walther, A. K. Heidinger, and Y. Li, 2016: Validation of VIIRS cloud base heights at night using ground and satellite measurements over Alaska. 2016 AGU Fall Meeting, San Francisco, CA, 12-16 December 2016.

Noh, Y. J., S. D. Miller, C. J. Seaman, J. M. Forsythe, D. T. Lindsey, A. K. Heidinger, and Y. Li, 2016: Improvement of satellite Cloud Base Height and Cloud Cover/Layers products. 7th Asia-Oceania/2nd AMS-Asia/2nd KMA Meteorological Satellite Users' Conference, Songdo City, Incheon, Korea, 21-28 October 2016.

Schumacher, A.B., 2017: Improving Real-Time Rapid Intensity Forecasts with Total Lightning Data, 97th Annual Meeting of the American Meteorological Society, 23-27 January 2017, Seattle, WA.

Seaman, C. J., D. T. Lindsey, S. D. Miller, J. A. Knaff, G. Chirokova, J. F. Dostalek, A. B. Schumacher, K. M. Musgrave, L. D. Grasso, J. Forsythe, R. DeMaria, D. A. Molenaar, 2016: CIRA/RAMMB Research

Activities in Support of the OCONUS. OCONUS Technical Interchange Meeting, Honolulu, HI, June 2016. (Invited speaker.)

Seaman, C. J., S. D. Miller, D. T. Lindsey, D. W. Hillger, 2016: Multi-spectral Imagery for the New Generation Geostationary Satellites: Applications for AHI, ABI and AMI. Australia-Oceania Meteorological Satellite User's Conference (AOMSUC), held jointly with the Korean Meteorological Administration (KMA) Satellite User's Conference, 24-27 October 2016, Incheon, South Korea.

Seaman, C. J., S. D. Miller, D. T. Lindsey and D. W. Hillger, 2017: JPSS and GOES-R Multispectral Imagery Applications and Product Development at CIRA (poster). 97th AMS Annual Meeting, Seattle, WA, 22-26 January 2017.

Seaman, C., S. Miller, D. Lindsey and D. Hillger: Multi-spectral applications and RGB composites for the new generation geostationary weather satellites. Yonsei University, Seoul, South Korea, 28 October 2016. Invited seminar presentation.

Szoke, E., D. Bikos, B. H. Connell, H. Gosden, S. D. Miller, J. Torres, R. L. Brummer, D. T. Lindsey, D. W. Hillger, D. A. Molenaar, C. J. Seaman, 2017: CIRA's Contribution to the NWS GOES-R Proving Ground: A Look Back at Pre-Launch Activities and a Look Ahead to Post-Launch Interactions. 97th AMS Annual Meeting, Seattle, WA, 22-26 January 2017.

PROJECT TITLE: CIRA Support for Tropical Cyclone Model Diagnostics and Product Development - Hurricane Forecast Improvement Project (HFIP)

PRINCIPAL INVESTIGATORS: Kate Musgrave, Wayne Schubert

RESEARCH TEAM: Andrea Schumacher, Robert DeMaria, Chris Slocum

TECHNICAL CONTACT: Fred Toepfer (NOAA/NCEP/EMC)

NOAA RESEARCH TEAM: John Knaff (NOAA/NESDIS/STAR) and Mark DeMaria (NWS/NCEP/NHC)

FISCAL YEAR FUNDING: \$315,000

PROJECT OBJECTIVES:

The National Oceanic and Atmospheric Administration (NOAA) initiated the Hurricane Forecast Improvement Project (HFIP) to reduce the errors in tropical cyclone track and intensity forecasts. This reduction will be accomplished through improved coupled ocean-atmosphere numerical hurricane models, better use of observations through advanced data assimilation techniques and ensemble forecasts. Model diagnostic techniques will also be developed to determine the sources of model errors and guide future improvements. The CIRA team performed tasks for three objectives that contribute to this HFIP effort. Details on these tasks are described in the next section.

The CIRA HFIP activities directly address NOAA's Weather Ready Nation objectives. This research falls within the NOAA-defined CIRA thematic area of Satellite Algorithm Development.

PROJECT ACCOMPLISHMENTS: Covering July 2016-March 2017

1—SHIPS/LGEM/RII Improvements

--Tasks associated with this objective fall into three general areas. The first area involves updating the SHIPS/LGEM/RII database with the 2016 season, and is ongoing. In addition to collecting the 2016 season, the GOES infrared database was extended backwards from 1995 to 1985. Code upgrades were implemented in the SHIPS/LGEM/RII code to include new satellite predictors from the GOES infrared principle components. The second area focuses on testing the inclusion of the ECMWF in SPICE. Previous work focused on implementing the ECMWF version of SHIPS/LGEM/RII on WCOSS. Using the SHIPS and LGEM forecasts run from ECMWF fields in the 2016 Atlantic and East Pacific hurricane seasons, a version of SPICE was built that combines the SHIPS and LGEM forecasts produced from the output of the GFS and ECMWF models. Figure 1 displays the preliminary results from the 2016 season. In the Atlantic (top panel), SHIPS has better mean absolute error (MAE) and bias throughout the forecast period than LGEM, for both GFS and ECMWF versions. The unweighted version of SPICE outperforms the weighted versions at longer forecast times. In the East Pacific (bottom panel), while LGEM generally showed lower MAE than SHIPS, the underforecast bias was higher for LGEM than for SHIPS, which had an underforecast bias of less than 5 kt at all forecast leads. While the MAE associated with the unweighted and weighted versions of SPICE were similar, the bias was less in the unweighted version, similar to the Atlantic results. In general, the GFS versions of SHIPS and LGEM outperformed the ECMWF versions, which might be due to the use of coefficients in the ECMWF version that are trained from the GFS fields. The third area focuses on providing rapid intensification guidance as part of the HFIP Ensemble Product Tiger Team. Retrospective RII and SPICE-RII guidance was provided for 2013-2015 Atlantic and East Pacific tropical cyclones (TCs). Real-time RII and SPICE-RII guidance was also provided for the 2016 demonstration period from August 1 through November 1 2016. The guidance is being updated and expanded to additional thresholds and will undergo further testing.

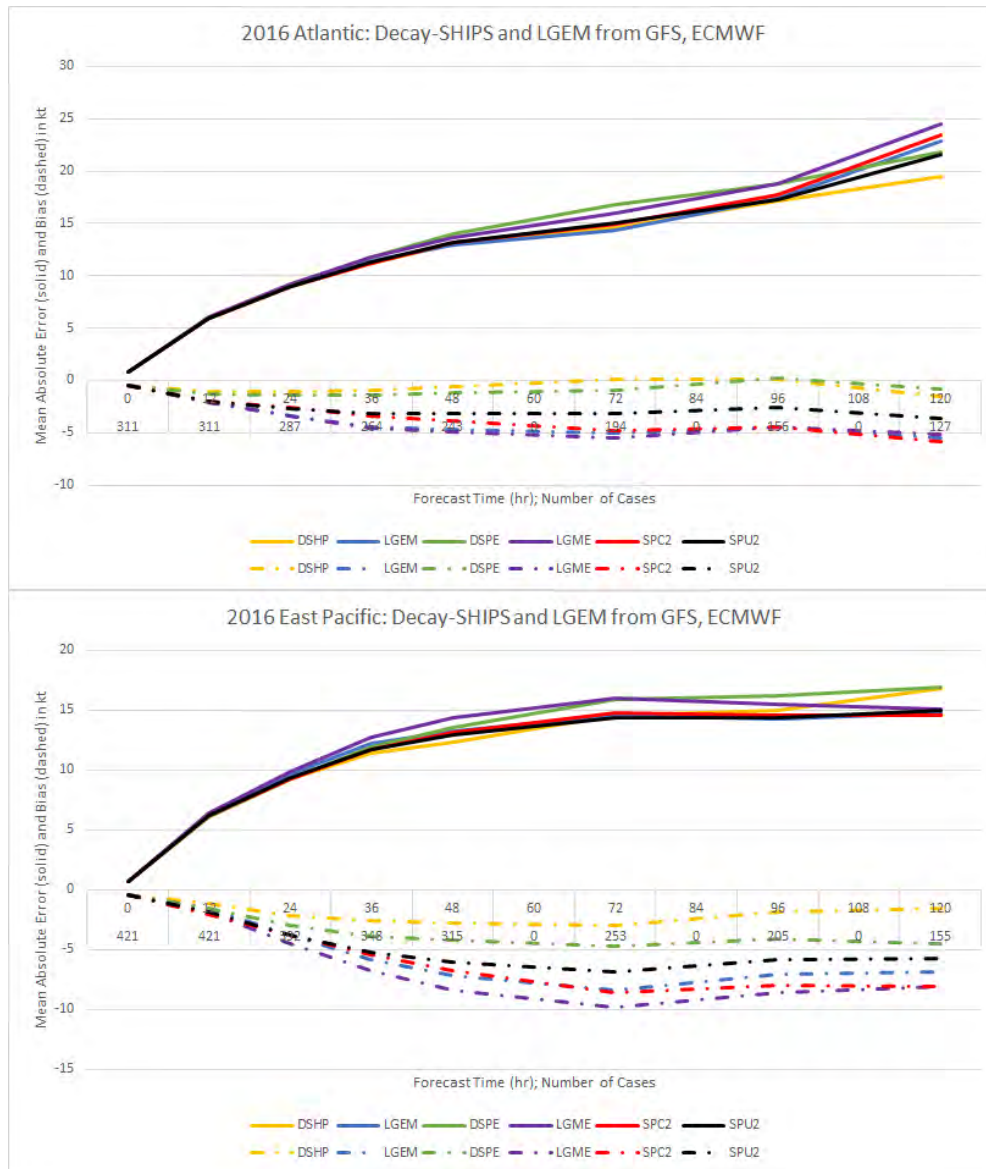

Figure 1. The mean absolute error (MAE, solid) and bias (dashed), in kt, for the 2016 Atlantic (top panel) and East Pacific (bottom panel) hurricane seasons, of the statistical-dynamical tropical cyclone intensity guidance Decay-SHIPS (DSHP) and LGEM, run from GFS and ECMWF (DSPE, LGME) model fields. Also shown are weighted (SPC2) and unweighted (SPU2) versions of SPICE, run from the ensemble of SHIPS and LGEM runs from GFS and ECMWF.

2—Improving the Monte Carlo Wind Speed Probability Model for Pre-Genesis

--To support the upcoming implementation of advisory products for potential tropical cyclones, a version of the Monte Carlo Wind Speed Probability (MCWSP) model was developed for weaker systems. While the distributions of WSP for weaker TCs (up to 50 kt maximum sustained winds) and stronger systems (over 50 kt maximum sustained winds) are different, the distribution of WSP for weaker systems was not sufficiently different from the overall distribution of WSP to be implemented as a separate model. An example for pre-Hurricane Hermine is shown in Figure 2, with the overall WSP distribution in the left panel, the weaker system WSP distribution in the middle panel, and the stronger system WSP distribution in the

right panel. After feedback from NHC, work is underway to develop a new cone of uncertainty based off the WSP distribution.

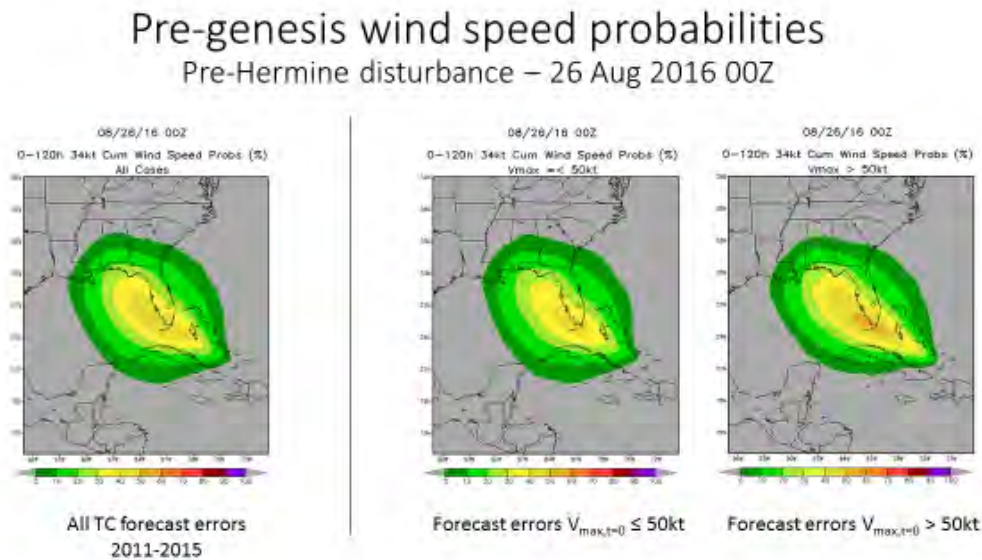

Figure 2. Model output for two idealized wind profiles (black) used to initialize and force a simple dynamical framework. The boundary layer response is shown for shock developing (blue) and non-shock developing (orange) cases.

3—Developing a Common Framework for Wind Speed Probabilities and Storm Surge Probabilities

--Work is underway to assess the framework needed to run the TC storm surge probabilities from the output of the MCWSP model, in order to unify the representation of the wind field in both TC wind and surge products. Current work is examining the radius of maximum winds (RMW) produced by the MCWSP model, which is a critical component of the surge model. The RMWs have been produced from the MCWSP model for 2016 Atlantic and East Pacific TCs and are being assessed.

Publications:

Knaff, J. A., C. J. Slocum, K. D. Musgrave, C. R. Sampson, and B. R. Strahl, 2016: Using routinely available information to estimate tropical cyclone wind structure. *Mon. Wea. Rev.*, 144:4, 1233-1247. doi: <http://dx.doi.org/10.1175/MWR-D-15-0267.1>

Presentations:

DeMaria, M., G. Chirokova, J. Knaff, K. D. Musgrave, and M. L. Bozeman, 2016: Recent improvements to NHC's statistical-dynamical tropical cyclone intensity prediction models. 32nd AMS Conference on Hurricanes and Tropical Meteorology, April 17-22, San Juan, PR.

Musgrave, K. D., M. DeMaria, and B. D. McNoldy, 2016: Global expansion of a statistical-dynamical ensemble for tropical cyclone intensity prediction (Poster). 32nd AMS Conference on Hurricanes and Tropical Meteorology, April 17-22, San Juan, PR.

Musgrave, K. D., M. DeMaria, and J. Kaplan, 2016: Examination of tropical cyclone rapid intensification guidance with multiple dynamical model inputs. 32nd AMS Conference on Hurricanes and Tropical Meteorology, April 17-22, San Juan, PR.

Schumacher, A. B., and M. DeMaria, 2016: Incorporating global model uncertainty information into the Monte Carlo Wind Speed Probability Model. 32nd AMS Conference on Hurricanes and Tropical Meteorology, April 17-22, San Juan, PR.

Slocum, C. J., 2016: Diagnosing large-scale tropical cyclone model moisture and exploring impacts on track and intensity (Poster). 32nd AMS Conference on Hurricanes and Tropical Meteorology, April 17-22, San Juan, PR.

Slocum, C. J., 2016: Forced, balanced model of tropical cyclone intensification. 32nd AMS Conference on Hurricanes and Tropical Meteorology, April 17-22, San Juan, PR.

PROJECT TITLE: CIRA Support of the Virtual Institute for Satellite Integration Training (VISIT) And Supplemental CIRA Support of the Virtual Institute for Satellite Integration Training (VISIT)

PRINCIPAL INVESTIGATORS: Dan Bikos and Bernadette Connell

RESEARCH TEAM: Edward Szoke, Erin Dagg, Kevin Micke, Rosemary Borger, and Tim David

NOAA TECHNICAL CONTACT: Satya Kalluri (NOAA/NESDIS) and Candice Jongsma (NOAA/OAR)

NOAA RESEARCH TEAM: Dan Lindsey (NOAA/NESDIS/STAR/RAMMB)

FISCAL YEAR FUNDING: \$172,000

PROJECT OBJECTIVES:

The primary objective of the VISIT program is to accelerate the transfer of research results based on atmospheric remote sensing data into National Weather Service (NWS) operations. This transfer is mainly accomplished through web based and distance learning methods. The primary distance learning methods utilized include teletraining and recorded modules. Teletraining is a "live" training session utilizing the VISITview software and a conference call to promote interaction between instructor and students. The audio / video playback format plays within a web-browser and is popular because it may be taken by a student individually whenever they choose. The combination of live teletraining and audio / video playback versions (Fig. 1) reaches out to as broad an audience as possible given the busy schedule of NWS forecasters. There have been over 7000 training completions over the past year and over 32,000 VISIT training completions since April 1999. Most student feedback suggests a direct applicability to current forecast problems. CIRA is also actively involved in tracking of participants, and the collection and summarization of course feedback material. Because the VISIT program has been successful within the NWS, it is being leveraged for other training activities in the US (Satellite Hydrology and Meteorology Courses (SHyMet), and the GOES-R/16 Proving Ground) and is being utilized by the International community in training programs under the World Meteorological Organization (WMO). For more information on the VISIT program, see: <http://rammb.cira.colostate.edu/visit/>

Specific Objectives:

- 1--Develop and deliver teletraining, recorded modules, and blog entries on the utilization of new satellite products that are available on AWIPS. This includes collaborating with and offering assistance to the GOES-R and JPSS satellite proving ground projects and other NOAA offices in the development and delivery of training materials.
- 2--Conduct monthly virtual "VISIT Satellite Chat" sessions.
- 3--Keep training participation metrics through the NOAA Commerce Learning Center
- 4--Attend meteorological and education conferences and symposiums and participate in other relevant organizational meetings. Engage in Community Outreach.

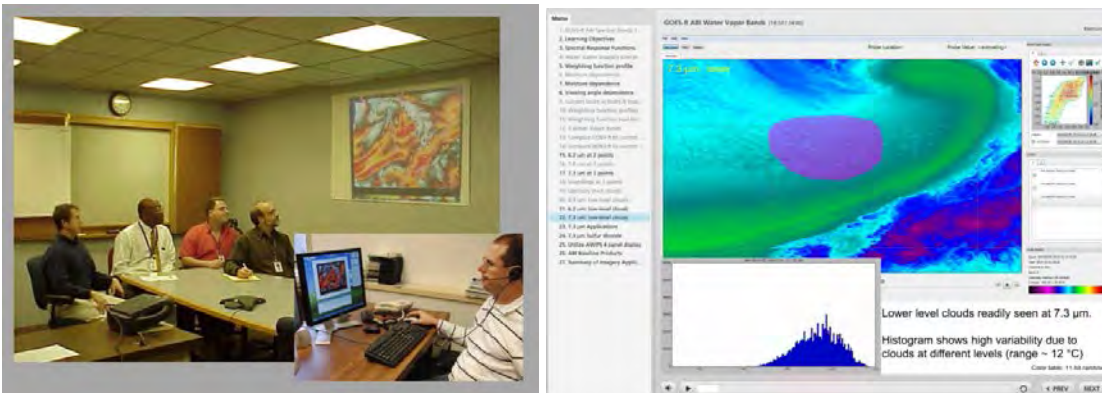

Figure 1. Live VISIT teletraining (left), and audio / video playback VISIT training module from SatFC-G course (right).

PROJECT ACCOMPLISHMENTS:

1--Training sessions:

SatFC-G: Satellite Foundational Course for GOES-R



- SatFC-G: "GOES-R General Circulation Patterns".
- SatFC-G: "GOES-R Atmospheric Rivers".
- SatFC-G: "Comparing NWP Synthetic Satellite Imagery to Observed Satellite Imagery".
- SatFC-G: "GOES-R Baseline product: Rainfall rate".
- SatFC-G: "GOES-R ABI Water Vapor Bands".
- SatFC-G: "GOES-R Cyclogenesis Life Cycle".
- SatFC-G: "GOES-R Cumulus Growth".
- SatFC-G: "GOES-R Marine and Polar Mesolows".
- SatFC-G: "GOES-R Mountain waves and orographic enhancement".
- SatFC-G: "GOES-R Boundary-forced convection".
- SatFC-G: "GOES-R Low-level jet features".
- SatFC-G: "GOES-R Pre-convective Cloud Features".
- SatFC-G: "GOES-R Pre-convective Environment".
- SatFC-G: "GOES-R Introduction to Mesoscale and Synoptic Sections".
- SatFC-G: "GOES-R Hurricane Intensity Estimate".
- SatFC-G: "GOES-R Mesoscale Convective Systems".
- SatFC-G: "GOES-R Discrete Storms".

Other:

- “Earth Networks Total Lightning Network (ENTLN) on AWIPS”.
- “Designing an Effective Survey: A beginning course for physical scientists”.

VISIT blog:

--The blog is intended to open the doors of communication between the Operational, Academic and Training Meteorology communities. The blog averages around 170 views per month and is located here: <http://rammb.cira.colostate.edu/training/visit/blog/>

2--VISIT Satellite Chat:

--Since February 2012, the VISIT team has led chat sessions to discuss recent significant weather events with the objective of demonstrating satellite products that can be applied to operational forecasting. These sessions are brief and often lead to products being made available or further discussed in the VISIT blog. In the past year, the following presenters led these sessions:

- Sheldon Kusselson (retired NOAA/NESDIS) titled “Satellite Derived Layered Precipitable Water (LPW) and Total Precipitable Water (TPW) products: Applications for the West Coast this 2016-2017 Winter Season”.
- Michael Jurewicz (NOAA/NWS WFO Binghamton, NY) titled “The “Super” Lake-Effect Event of 19-21 November 2016 across Western/Central New York”.
- Scott Lindstrom (CIMSS/SSEC/UW) on the Oregon tornado event of 14 October 2016.
- Andrea Schumacher (CIRA/CSU NHC Satellite Liaison) and Michael Folmer (Satellite Liaison for OPC/SAB/TAFB/WPC) on Hurricane Matthew.
- Brad Pierce (NOAA/NESDIS/STAR) title “High Resolution Trajectory-Based Smoke Forecasts of the Fort McMurray wildfire using VIIRS Aerosol Optical Depth”.
- Michael Folmer (Satellite Liaison for OPC/SAB/TAFB/WPC) titled “February Hurricane-Force Events: OPC perspective on GOES-14 SRSOR”.
- Matt Elliot (NOAA/NWS WFO Sterling, VA) on AWIPS Lightning Outages.

Recorded sessions are located here (example shown in Fig. 2):
http://rammb.cira.colostate.edu/training/visit/satellite_chat/

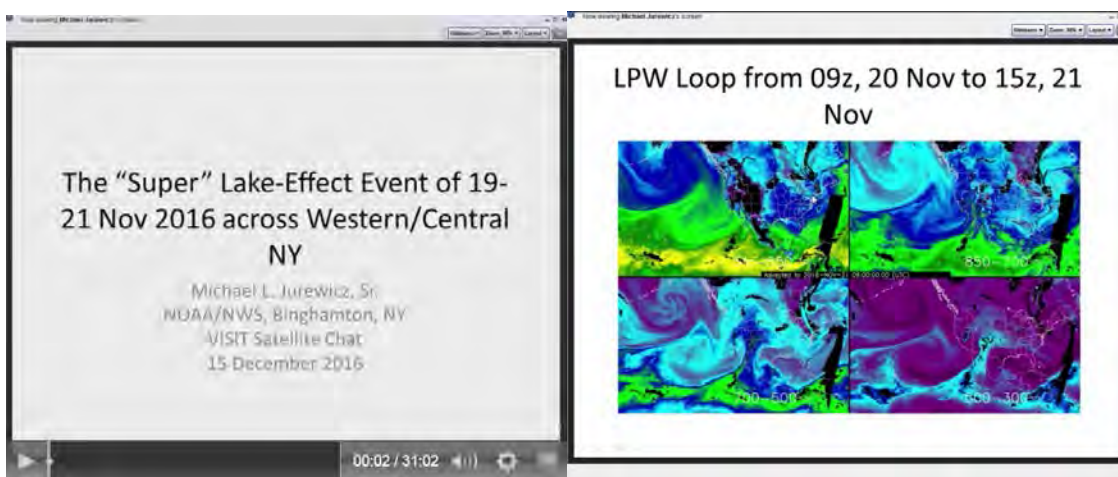

Figure 2. Live VISIT Satellite Chat session recording made available on VISIT web-pages.

3--VISIT training metrics April 1, 2016 – February 14, 2017:

- Live teletraining: 40 sessions delivered to 110 participants.
- Audio / video playback (through NOAA’s Learning Management System as well as directly through CIRA’s web interface): 7189 participants.

4--Community Outreach:

--Outreach activities at NOAA/Boulder: Ed Szoke gave an hour long weather talk at "8th Grade Science Days" on 6 and 11 October and to a visiting 5th Grade class on 3 November. He also participated in the NOAA Family Tour day on 20 December. Ed Szoke has also been advising (as a Committee Member) a Master's student in meteorology at the University of Colorado in Boulder, Matt Steiner, with his defense scheduled for March 2017.

Publications: None

Presentations:

Bikos, D., and S. Lindstrom, 2016: Status of recent / near future VISIT / SHyMet as it relates to the Satellite Foundational Course for GOES-R (SatFC-G). NOAA Satellite Proving Ground / User Readiness Week, 9-13 May, Norman, Oklahoma.

Bikos, D., S. Lindstrom, S. Bachmeier, E. Szoke, B. Connell, E. Dagg, B. Ward, A. Mostek, 2016: VISIT / SHyMet contributions to the Satellite Foundational Course (SatFC-G). Poster, National Weather Association (NWA) Annual Meeting, 10-15 September, Norfolk, Virginia.

Bikos, D. and J. Torres: Training on the Weather Event Simulator (WES-2) provided for the Experimental Products Development Team at CIRA, 9 December 2016.

Connell, B., D. Bikos, S. Lindstrom, J. Torres, E. J. Szoke, E. L. Dagg, A. B. Schumacher, A. S. Bachmeier, A. Mostek, B. C. Motta, M. Davison, and L. Veeck, 2017: Satellite user readiness through training: VISIT, SHyMet, WMO VLab and liaisons. 13th Annual Symposium on New Generation Operational Environmental Satellite Systems, Seattle, WA, Amer. Meteor. Soc., 23-26 January 2017, Talk.

Connell, B., D. Bikos, S. Lindstrom, E.J. Szoke, S. Bachmeier, J. Torres, E. Dagg, T. Mostek, B. Motta, M. Davison, and L. Veeck, 2016: Satellite User Readiness Through Training: VISIT, SHyMet, and WMO VLab. AMS 21st Satellite Meteorology Conference, Madison, WI, 15-19 August, Poster.

Jurewicz Sr., M. L., C. M. Gitro, S. J. Kusselson, J. M. Forsythe, A. S. Jones, S. Kidder, D. Bikos, and E. J. Szoke, 2017: Synoptic comparison of two high-impact predecessor rainfall events: Tropical Storm Lee/Hurricane Katia of September 2011 and Hurricane Joaquin of October 2015. AMS 28th Conference on Weather and Forecasting/24rd Conference on Numerical Weather Prediction, Seattle. Amer. Meteor. Soc., 23-25 January 2017, Talk.

Szoke, E.J., 2016: Talks on GOES-R Proving Ground updates at the Boulder Weather Forecast Office (WFO) Winter Workshops on 30 September & 7 October 2016.

Szoke, E.J., 2016: Talk on GOES-R Proving Ground updates at the Cheyenne Weather Forecast Office (WFO) on 1 December 2016.

Szoke, E. J., S. G. Benjamin, C. R. Alexander, E. P., J. M. Brown, D. Barjenbruch, R. Kleyla, and B. Meier, 2017: An examination of HRRR and HRRRX performance and utility for two similar and challenging Colorado snowstorms. AMS 28th Conference on Weather and Forecasting/24rd Conference on Numerical Weather Prediction, Seattle, Amer. Meteor. Soc., 23-26 January 2017, Talk.

Szoke, E., S. G. Benjamin, C. R. Alexander, E. P., J. M. Brown and S. Weygandt, 2016: The latest on the HRRR model after a recent upgrade. 41st NWA Annual Meeting, Norfolk, VA, 12-15 September, Talk.

Szoke, E., D. Bikos, R. Brummer, H. Gosden, D. Molenaar, D. Hillger, S. Miller, D. Lindsey, B. Connell and C. Seaman, 2016: CIRA's current and future contributions to the GOES-R Proving Ground as we

approach the launch of GOES-R. AMS 21st Satellite Meteorology Conference, Madison, WI, 15-19 August, Poster.

Szoke, E., D. Bikos, R. Brummer, H. Gosden, D. Molenaar, D. Hillger, S. Miller, D. Lindsey, J. Tores and C. Seaman, 2016: What happens next for CIRA's NWS Proving Ground activities after the launch of GOES-R. 41st NWA Annual Meeting, Norfolk, VA, 12-15 September, Poster.

Szoke, E., D. Bikos, R. Brummer, H. Gosden, D. Molenaar, D. Hillger, S. Miller, D. Lindsey, J. Tores and C. Seaman, 2017: CIRA's contribution to the NWS Proving Ground: A look back at pre-launch activities and a look ahead to post-launch interactions. 13th Annual Symposium on New Generation Operational Environmental Satellite Systems, Seattle, WA, Amer. Meteor. Soc., 23-26 January 2017, Talk.

Ward, B., A. Mostek, R. Van Til, L. Spayd Jr., F. W. Alsheimer, M. T. Stavish, D. Nietfeld, B. C. Carcione, N. Eckstein, W. Abshire, P. Dills, G. T. Stano, J. G. LaDue, M. A. Bowlan, D. Bikos, B. H. Connell, E. Szoke, E. L. Dagg, S. Bachmeier, S. Lindstrom, J. Gerth, and T. Schmit, 2017: The Satellite Foundational Course for GOES-R: A collection of lessons to prepare National Weather Service forecasters for GOES-R. AMS 28th Conference on Weather and Forecasting/24rd Conference on Numerical Weather Prediction, Seattle, Amer. Meteor. Soc., 23-26 January 2017, Talk.

PROJECT TITLE: CSU/CIRA Support for ATMS SI Traceable Calibration Effort

PRINCIPAL INVESTIGATORS: Christian Kummerow, Thomas Vonder Haar

RESEARCH TEAM: Wes Berg, ATS, John Forsythe and Heather Cronk

NOAA TECHNICAL CONTACT: Fuzhong Weng, NOAA/NESDIS

NOAA RESEARCH TEAM: Ninghai.Sun NOAA/NESDIS/STAR/SMCD

FISCAL YEAR FUNDING: \$99,517

PROJECT OBJECTIVE:

To assess the calibration differences between ATMS water vapor channels and the corresponding channels on the newly available GMI instrument on board the GPM satellite. Given GPM's 65° inclination, frequent coincident overpasses are available with NPP/ATMS. We plan to use a double difference approach to compare radiances during these satellite coincidences. Specifically, we will perform the following tasks:

--Apply geophysical retrievals from a 1DVAR retrieval developed for GPM GMI as a basis for double difference computations to assess the accuracy and stability of ATMS and GMI channel differences. Compare with double difference results based on geophysical parameters from ECMWF interim reanalysis.

--Investigate calibration changes/differences using specified double difference approach for both NPP ATMS SDR reprocessing and ATMS on board JPSS1 once data becomes available.

--Double differences between ATMS and SAPHIR data from Megha-Tropiques will also be computed to investigate calibration consistency for channels without GMI counterparts.

--Investigate impact of differences between state-of-the-art radiative transfer models on the resulting double differences. This will include both ocean emissivity models for window and/or semi-transparent water vapor channels as well as atmospheric absorption models.

--Use in-situ observed from field programs including DYNAMO in late 2011 to investigate differences between simulated and observed brightness temperatures over clear-sky and non-precipitating ocean scenes to compare with 1DVAR results (using TRMM TMI) and investigate radiative model sensitivities.
 --Report results to the ATMS SDR team.

PROJECT ACCOMPLISHMENTS:

During the past year much of the focus of this project has been on developing and adapting a 1DVAR geophysical retrieval algorithm for non-precipitating ocean scenes and using the retrieved parameters to investigate double differences between GPM GMI and NPP ATMS. Previous double difference comparisons have relied on geophysical parameters from global model analyses such as the ECMWF Interim reanalysis. Results to date indicate that geophysical parameters including water vapor profile information from the 1DVAR retrieval significantly reduce the scatter in the double differences between sensors versus using model analyses. This is particularly important for channels with significant sensitivity to water vapor and the associated vertical profile. Figure 1 shows a comparison between using the 1DVAR versus ECMWF Interim reanalysis for a 3-month comparison of double differences between GPM GMI and MHS on board METOP-A.

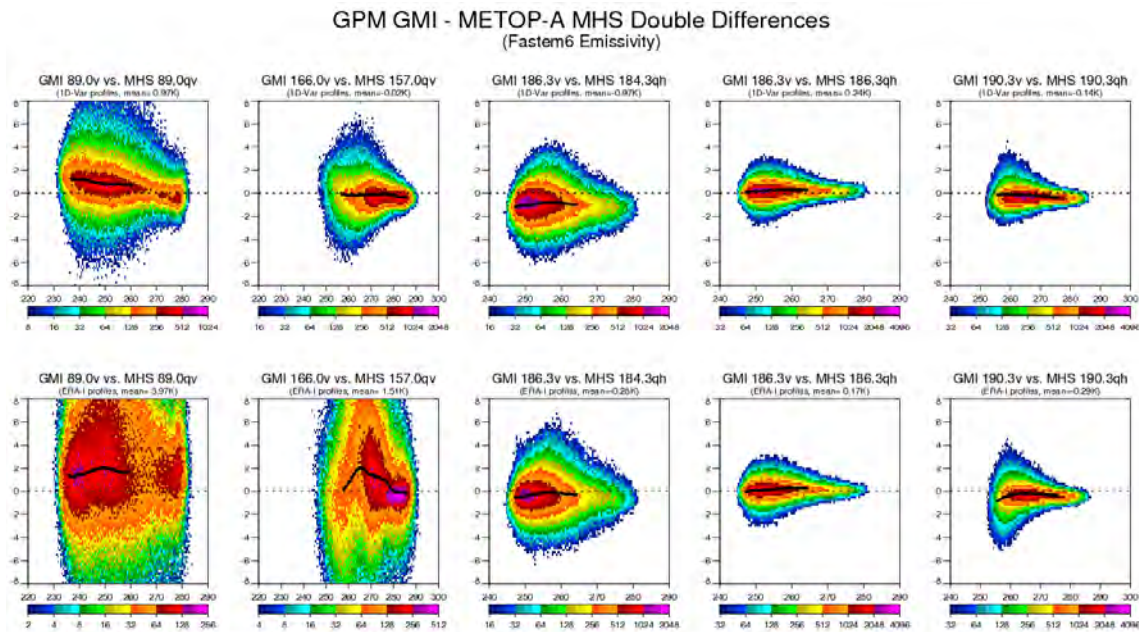

Figure 1. Comparison of double difference results between GPM GMI and METOP-A MHS using 1DVAR retrievals (top row) and ECMWF Interim reanalysis (bottom row). Colors indicate density of individual values while black line shows mean double difference values binned by GMI Tb (x-axis).

Initial comparisons between GPM GMI and NPP ATMS were done using both the 1DVAR and ERA-Interim parameters. In addition, two different ocean surface emissivity models were used include one from Remote Sensing Systems (RSS) and the latest FASTEM6 model in the Community Radiative Transfer Model (CRTM). Results are shown in Table 1.

Table 1. Double differences between GPM GMI and NPP ATMS using different geophysical parameters (1DVAR and ERA-Interim) and ocean emissivity models (RSS and FASTEM6).

Geophys Params	Emis Model	23qv	31qv	88qv	165qh	183±1qh	183±1.8qh	183±3qh	183±4.5qh	183±7qh
1D-Var	FASTEM6	-1.51	-1.61	1.05	0.27	-1.88	-0.46	0.56	1.20	0.42
1D-Var	RSS	-0.14	-0.42	-0.31	1.03	-1.89	-0.47	0.56	1.20	0.40
ERA-Interim	FASTEM6	-1.25	-1.90	4.43	0.88	-1.37	-0.33	0.38	0.72	0.15
ERA-Interim	RSS	0.11	-0.67	3.13	1.57	-1.39	-0.33	0.37	0.73	0.13

The results shown in Table 1 indicate significant sensitivity to the ocean emissivity model for the window channels. The results also show that the 1DVAR retrievals have the most impact on the 88 and 165 GHz channels, which have significant sensitivity to water vapor as well as the ocean surface. Investigation of the model and parameter sensitivity is ongoing using in-situ surface flux and radiosonde observations taken during the DYNAMO campaign over the equatorial Indian ocean in late 2011.

Finally, Figure 2 shows a comparison of double differences as a function of ATMS scan position using the RSS and FASTEM6 emissivity models. While the opaque water vapor channels show no sensitivity as expected, there are significant differences in both the mean and cross-track patterns for the window and semi-transparent water vapor channels.

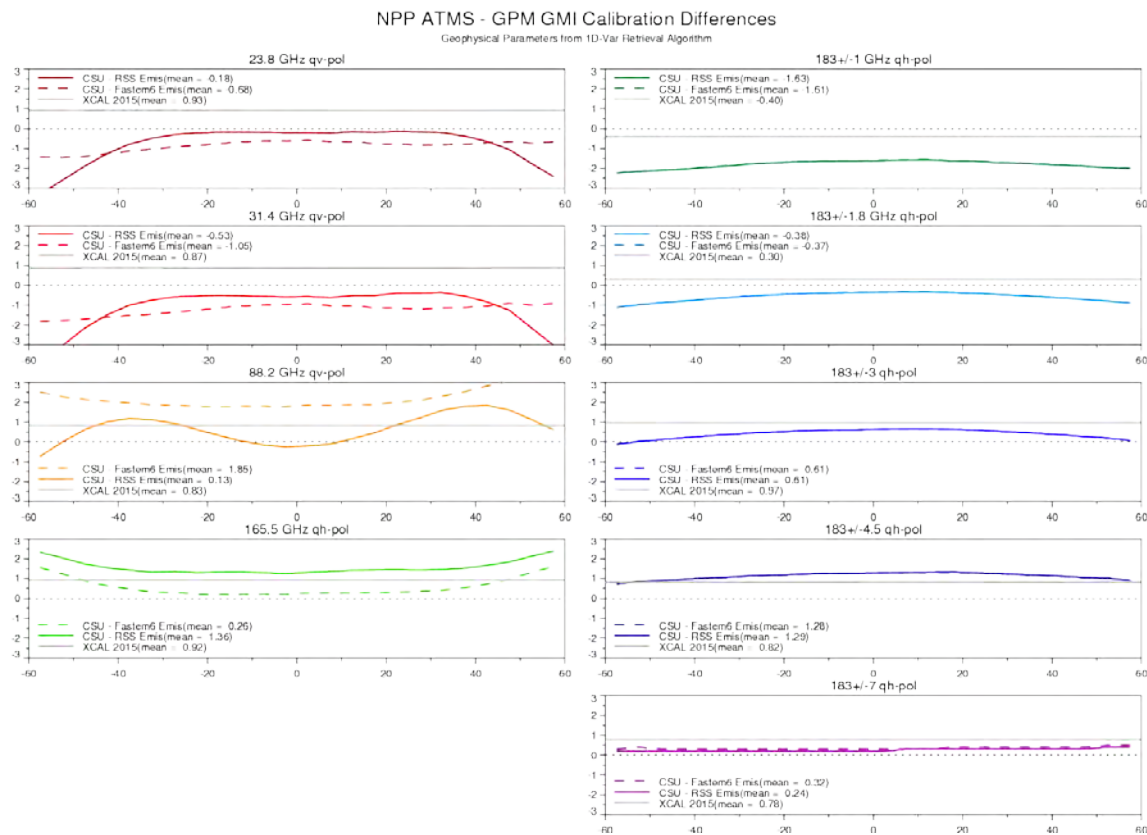

Figure 2. Double differences between GPM GMI and NPP ATMS as a function of ATMS scan position using both the RSS and FASTEM6 ocean emissivity models.

During the past year we have also regularly attended the ATMS SDR bi-weekly telecons and have presented some results from the GPM XCAL team and a workshop on errors and uncertainties in the 183 GHz channels.

Publications:

Brognez, H., English, S., Mahfouf, J.-F., Behrendt, A., Berg, W., Boukabara, S., Buehler, S. A., Chambon, P., Gambacorta, A., Geer, A., Ingram, W., Kursinski, E. R., Matricardi, M., Odintsova, T., Payne, V., Thorne, P., Tretyakov, M., and Wang, J.: A review of sources of systematic errors and uncertainties in observations and simulations at 183GHz, *Atmos. Meas. Tech. Discuss.*, doi:10.5194/amt-2016-9, in review, 2016.

Duncan, D.I. and C. D. Kummerow, 2016: A 1DVAR Retrieval Applied to GMI: Algorithm Description, Validation, and Sensitivities. *J. Geophys. Res.: Atmospheres*, 121, 7415-7429.

PROJECT TITLE: CSU/CIRA Support for ATMS SI Traceable Calibration Effort: Part 2

PRINCIPAL INVESTIGATORS: Christian Kummerow, Thomas Vonder Haar

RESEARCH TEAM: Wes Berg, ATS, John Forsythe and Heather Cronk

NOAA TECHNICAL CONTACT: Fuzhong Weng, NOAA/NESDIS

NOAA RESEARCH TEAM: Ninghai.Sun NOAA/NESDIS/STAR/SMCD

PROJECT OBJECTIVES:

1--Examine differences in total precipitable water (TPW) retrievals between various passive microwave retrieval algorithms which may be used in reference environmental data record creation. The retrievals which were compared are the 1DVAR method of Elsaesser and Kummerow (2008; referred to as EK2008), the NOAA Microwave Integrated Retrieval System (MIRS, Boukabara et al. 2011), and the 1DVAR GPM GMI retrieval developed at CSU (Duncan and Kummerow, 2016).

2--Demonstrate creation of global TPW fields using current a current operational sensor (DMSP F18 SSMS) and quantify the impact of sensor intercalibration on TPW retrievals via the new GPM GMI sensor.

PROJECT ACCOMPLISHMENTS:

1--Daily fields of TPW were retrieved for July 2014 and January 2015 from DMSP F18 and GPM GMI. A series of difference maps and scatter plots were created for the three algorithms compared.

2--Using monthly average difference maps (Figure 1), our investigation revealed regional biases in TPW introduced by the assumptions in the EK2008 retrieval. As compared to the MIRS retrievals, EK2008 TPW is higher along the ITCZ region and lower in the mid-latitudes. As compared to GMI, EK2008 retrieves higher values of TPW at almost all latitudes, with a particularly high bias in the ITCZ region. There are pockets in the Northern Hemisphere mid-latitudes and near Antarctica where EK2008 values of TPW are less than GMI. These areas are more pronounced in January 2015.

3--Monthly average scatter plots (shown in Figure 2) reveal that, compared to MIRS in the same location, EK2008 retrieved TPW is generally higher for high (> 50mm) values. For mid-values of TPW (30-35mm), the MIRS retrieved TPW tends to be higher than EK2008, a phenomenon that is more apparent in the monthly averages. When comparing EK2008 to GMI retrievals, there is a much less coherent correlation in the daily TPW values but for the monthly averages, there is a tendency for the EK2008 TPW value to be higher than GMI as values of TPW increase.

4--These results provide valuable insights into the regional difference of passive microwave retrievals of TPW which could be used to guide future construction of multidecadal reference environmental data records.

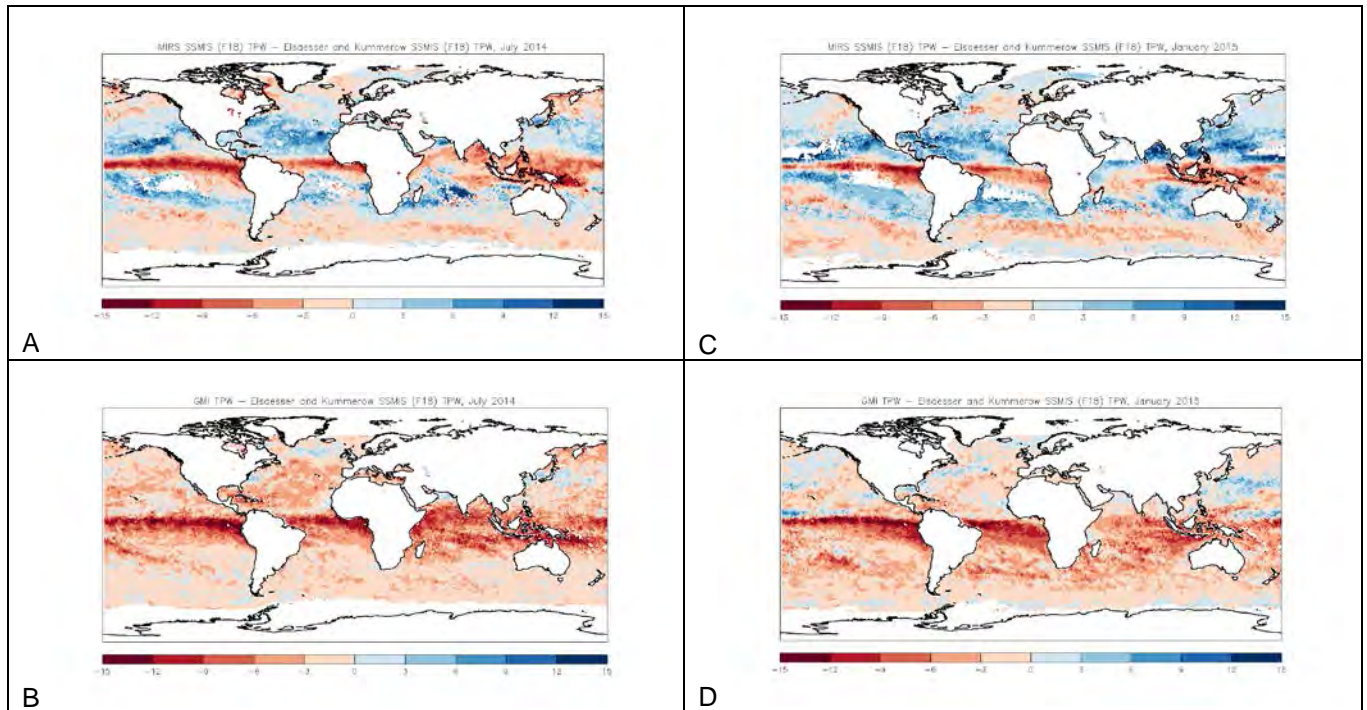

Figure 1. Monthly average TPW difference maps for MIRS F18 - EK2008 and GMI - EK2008 for July 2014 (A and B, respectively) and January 2015 (C and D, respectively).

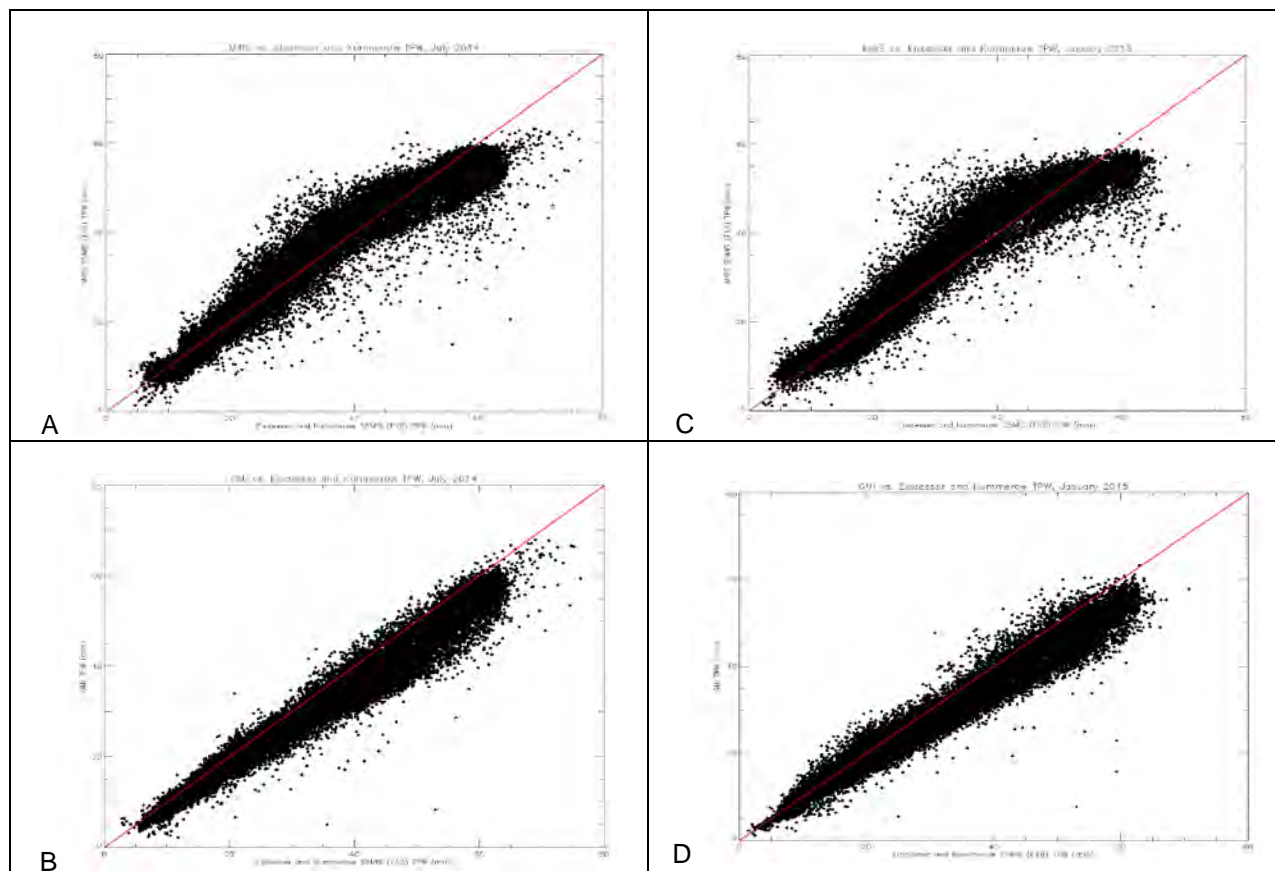

Figure 2. Monthly average TPW scatter plots for MIRS F18 - EK2008 and GMI - EK2008 for July 2014 (A and B, respectively) and January 2015 (C and D, respectively). EK2008 plotted on abscissa.

PROJECT ACCOMPLISHMENTS:

During the past year we have also regularly attended the ATMS SDR bi-weekly telecons and have presented some results from the GPM XCAL team and a workshop on errors and uncertainties in the 183 GHz channels.

Another element of this project is to demonstrate the capability of the Duncan and Kummerow (2016 – DK16) 1DVAR retrieval for additional sensors. The total precipitable water (TPW) retrieval from GMI shows performance which rivals benchmark products, with RMS errors of < 3 mm. The 1DVAR retrieval has been implemented on ATMS data in near-realtime, and implementation on older Special Sensor Microwave / Imager (SSM/I) data is in progress. This effort provides the groundwork to create future multidecadal water vapor datasets with the 1DVAR retrieval. A key task as discussed in DK16 is the specification of the instrument and model error covariance matrix using many comparisons of simulated versus measured radiances. A diagonal measurement error covariance matrix is used for the initial ATMS implementation. Nine of 22 ATMS channels are used (23, 31, 88, 165 and the 183 GHz channels).

A comparison of the ATMS 1DVAR TPW versus the NOAA operational Microwave Integrated Retrieval System (MiRS) TPW product is shown in Figure 3. This is from a S-NPP overpass over the Pacific Ocean on 28 March 2017 at 1115 UTC. Both retrievals use the CRTM, but MiRS uses all sensor channels and retrieves temperature and precipitation profiles as well as the water vapor profile which is

integrated to provide TPW. Only matchups with high 1DVAR confidence and low chi-squared values are shown. While the correlation is very high (0.99), the RMS and bias are slightly above 4 mm. Future refinements to the 1DVAR measurement error covariance matrix will likely improve the 1DVAR performance.

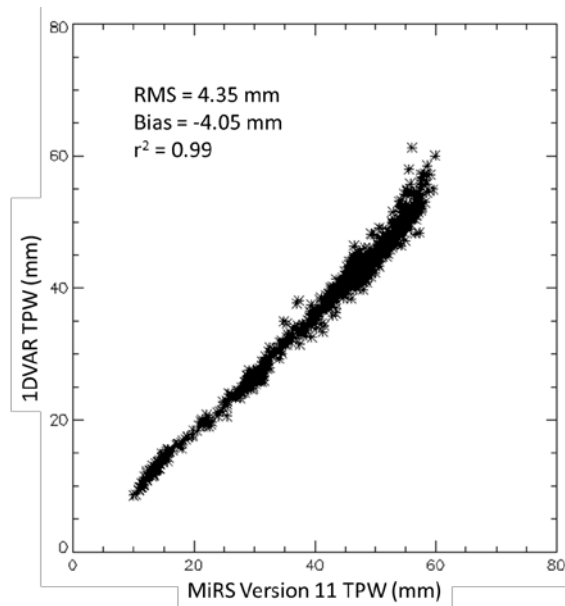

Figure 3. ATMS 1DVAR TPW versus MiRS TPW for 28 March 2017

Boukabara, S.-A., et al., 2011: MiRS: An All-Weather 1DVAR Satellite Data Assimilation and Retrieval System. *IEEE Trans. Geosci. Remote Sens.*, **49**, 3249-3272.

Brognez, H., English, S., Mahfouf, J.-F., Behrendt, A., Berg, W., Boukabara, S., Buehler, S. A., Chambon, P., Gambacorta, A., Geer, A., Ingram, W., Kursinski, E. R., Matricardi, M., Odintsova, T., Payne, V., Thorne, P., Tretyakov, M., and Wang, J.: A review of sources of systematic errors and uncertainties in observations and simulations at 183GHz, *Atmos. Meas. Tech. Discuss.*, doi:10.5194/amt-2016-9, in review, 2016.

Duncan, D.I. and C. D. Kummerow, 2016: A 1DVAR Retrieval Applied to GMI: Algorithm Description, Validation, and Sensitivities. *J. Geophys. Res.: Atmospheres*, **121**, 7415-7429.

Elsaesser, G. S. and C. D. Kummerow, 2008: Towards a fully parametric retrieval of the non-raining parameters over the global ocean. *J. Appl. Meteor. & Climatol.*, **47**, 1590 – 1598.

PROJECT TITLE: NESDIS Environmental Applications Team, I-Wen Chu – Research Scientist

PRINCIPAL INVESTIGATORS: Steven Miller, Cliff Matsumoto

RESEARCH TEAM: Mike Chu

NOAA TECHNICAL CONTACT: Menghua Wang

NOAA RESEARCH TEAM: Menghua Wang (NOAA Team Lead)

FISCAL YEAR FUNDING (NEAT Total): \$2,104,544

PROJECT OBJECTIVES:

- Complete the full evaluation of all SNPP VIIRS reflective solar bands (M1-M11 not including M9) sensor data, including the imagery bands I1-I3.
- Develop a new variant of the current standard calibration methodology for reflective solar bands.
- Perform VIIRS instrument characterization and calibration for ocean color data processing and applications.
- Examine instrument performance and bring to attention any new effects.

PROJECT ACCOMPLISHMENTS:

- Completed the evaluation of the sensor data record for SNPP VIIRS M1-M8 generated by the team and validated its accuracy to mid-2016 (Submitted for publication).
- Successfully evaluated the performance stability of SNPP VIIRS M11 never before done.
- Discovered and proven, in collaboration with Dr. Junqiang Sun, a significant physical effect in “solar diffuser” that introduces serious errors into the SNPP VIIRS sensor data (published).

Publications:

Chu, M., J. Sun, and M. Wang. An exposition on the solar diffuser degradation non-uniformity effect for SNPP VIIRS and Terra/Aqua MODIS. Proc. SPIE 2016, 9972, 99721E.

Chu, M., J. Sun, and M. Wang. Radiometric evaluation of the SNPP VIIRS reflective solar band sensor data records via inter-sensor comparison with Aqua MODIS. Proc. SPIE 2016, 9972, 99721R.

Sun, J., M. Chu, and M. Wang. Degradation nonuniformity in the solar diffuser bidirectional reflectance distribution function. *Appl. Opt.* 2016, 55,6001-6016.

PROJECT TITLE: NESDIS Environmental Applications Team, Yanni Ding, Post Doc - NOAA L3U SST Products and Monitoring in ARMS

PRINCIPAL INVESTIGATOR(S): Steve Miller, Cliff Matsumoto

RESEARCH TEAM: Yanni Ding

NOAA TECHNICAL CONTACT: Alexander Ignatov

NOAA RESEARCH TEAM: Alexander Ignatov, Irina Gladkova, Michael Grossberg, Calvin Chu, Fazlul Shahriar, Boris Petrenko, Yury Kihai, Peter Hollemans, Kai He

FISCAL YEAR FUNDING (NEAT Total): \$2,104,544

PROJECT OBJECTIVE:

Sustain and improve NOAA ACSPO (Advanced Clear-Sky Processor for Ocean) Regional Monitor for SST system (ARMS); Optimize ACSPO Level 3U (U=Uncollated) (L3U) SST code for VIIRS; Generalize L3U code to process other high-resolution sensors (MODIS, AVHRR FRAC).

PROJECT ACCOMPLISHMENTS:

ACSPO Regional Monitor for SST: ARMS (www.star.nesdis.noaa.gov/sod/sst/arms/) was updated to version 2. The interface of the new system is shown in Figure 1.

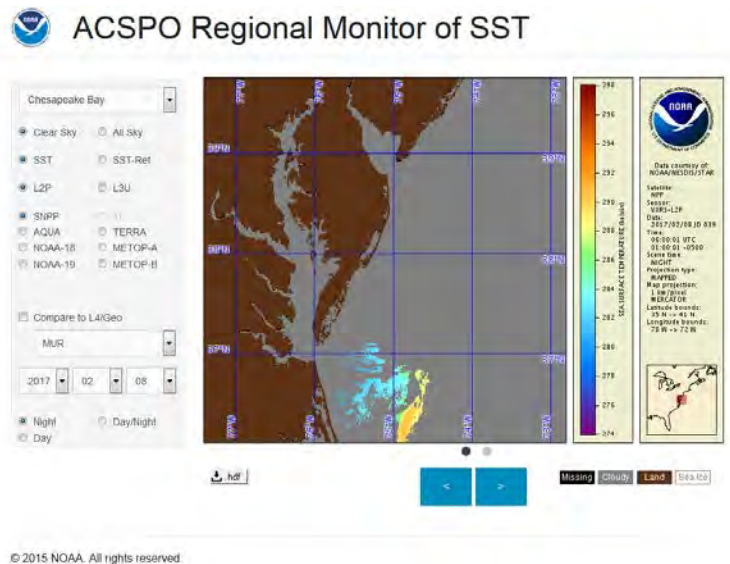

Figure 1. A screenshot of the ARMS system version 2.

The ARMS system monitors performance of ACSPO SST in selected challenging regions of the ocean (dynamic and coastal zones, cloudy areas, and high latitudes) from several polar platforms and sensors, including SNPP VIIRS, Terra and Aqua MODISs, and several AVHRRs onboard NOAA18/19 and Metop A/B. For Metop-A and -B, both GAC and FRAC products are included.

In v1, only one L3U SST product (from SNPP VIIRS) was displayed, and only L2P products were available for all other sensors. With the current NOAA SST move towards a unified line of L3U products from all sensors, two data level buttons “L2P” and “L3U” are now available (see Fig. 1). Once L3U products from other platforms and sensors are available, they will be added to ARMS.

Another improvement in v2 is the inclusion of several Level 4 (L4) products (including JPL MUR, Met Office OSTIA and NOAA Geo Polar Blended), and several ACSPO geostationary SSTs (from Himawari-8 AHI, and GOES-16 ABI). Functionality is in place to inter-compare various polar and geostationary L2/L3 ACSPO SSTs, and L4s. L4 SSTs is available for all twenty special regions (including “Monterey Bay” region, newly added by users’ request). AHI covers three special regions (South China Sea, Kuroshio Current and Korea Strait) falling in its retrieval domain, and ABI covers 10 special regions along the US West Atlantic Ocean and East Pacific Ocean. When the “Compare to L4/Geo” button is checked, the corresponding geostationary SSTs closest in time would display or daily L4.

In ARMS v2, all SST images now have better resolution than in v1.

The ARMS system was presented at the 17th GHRSSST meeting in June 2016 and at the JPSS meeting in August 2016.

VIIRS L3U (“uncollated”) SST product:

L3U v2 code has been tested, optimized and experimentally run at NOAA. Similarly, to L2P, the L3U product is reported in 10-min granules. The size of L3U data is significantly smaller than L2P (< 1GB/day compared to ~27 GB). The average running time to convert one 10-min ACSPO L2P into L3U granule is ~16 sec in v2, faster than for v1.

The L2P-to-L3U code employs bi-lateral weighted averaging. The SST value at each grid cell is computed based on spatial proximity to the cell, as well as on the proximity of the SST value to a median SST of the spatially-close L2 swath values. This approach is known to reduce noise in the imagery, while preserving the edges, thus minimizing distortions to the high-resolution SST structure present in swath L2P data.

A full set of masking flags (cloud and ice masks, etc.), which was missing in v1, is now added in v2, and reported in L3U granules, consistently with ACSPO L2P GDS2 files. The L2P flags are processed based on the “majority rule”. Each individual bit of L2P flags is set to 1, if 50% of contributing L2P pixels have flag=1, and to 0 otherwise.

As in v1, only data with best quality level (QL=5) are reported in L3U. QL is set to 5 in two cases: 1) when the Gaussian weight of L2P pixels with QL=5 exceeds the Gaussian weight of L2P pixels with QL<5, or 2) if the absolute difference between the SST calculated by a nearest neighbor method and SST retrieved from bi-lateral weighted averaging, does not exceed 1.5K. The 2) is introduced to preserve good pixels which may be conservatively rejected by 1).

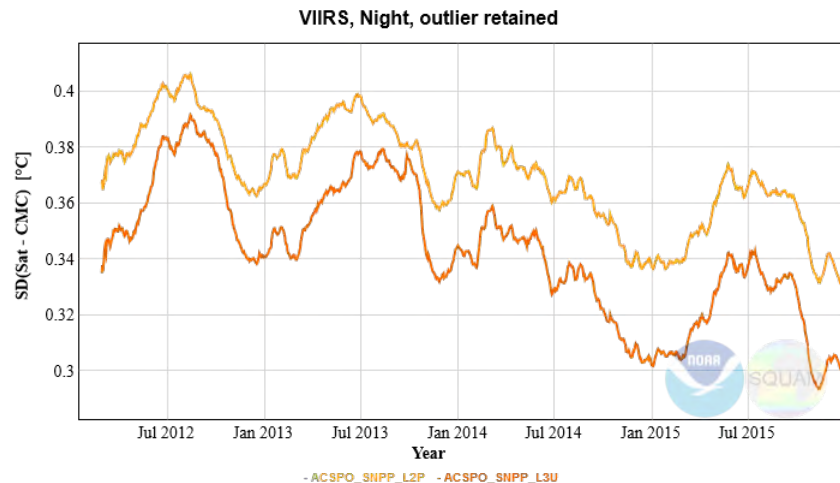

Figure 2. Time series of standard deviation of VIIRS L3U – CMC L4 and L2P – CMC L4. Data are running one-month smoothing.

In conjunction with other team members, reanalysis and near-real-time VIIRS L3U SSTs are continuously monitored in the NOAA SST Quality Monitor v2 (SQUAM; www.star.nesdis.noaa.gov/sod/sst/squam2) system. When comparing to CMC L4 SST, the standard deviation of L3U v2 SST is consistently smaller than L2P with an average reduction of ~ 0.3 Kelvin (Fig. 2). The spatial patterns of SST are more accurately preserved in v2 (cf. the locations of fronts in L2P and L3U, in Fig. 3). The data coverage in L3U is a little bit higher than L2P with an increase around 4%.

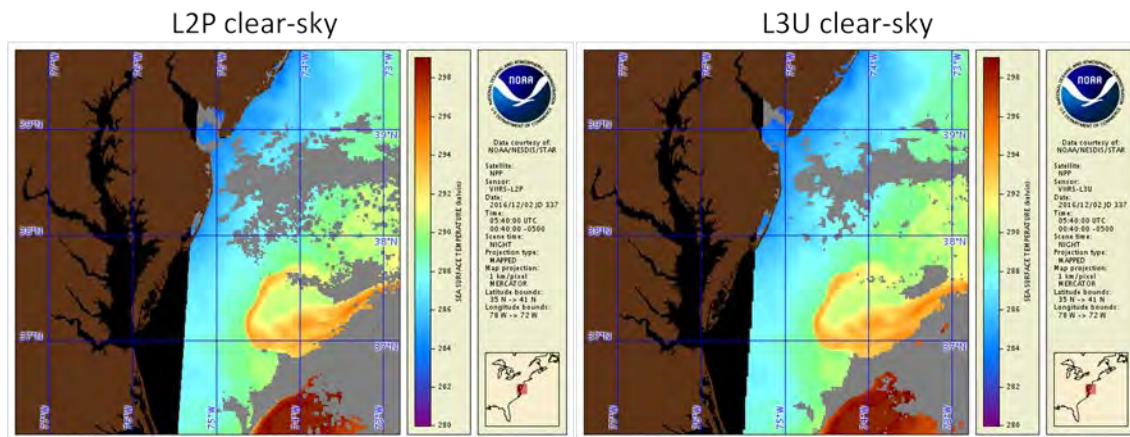

Figure 3. An example showing location of fronts in L2P and L3U v2 SST product.

Work is underway to generate consistent L3U products for other platforms, with 0.02° resolution for high-resolution sensors (AVHRR FRAC, MODIS) and 0.08° for AVHRR GAC, using the same algorithm, with adjusted window size and the weighting parameters, depending upon sensors.

Publications:

Ignatov, A., I. Gladkova, Y. Ding, F. Shahriar, Y. Kihai, X. Zhou, JPSS VIIRS Level 3 Uncollated SST Product at NOAA, *J. Appl. Remote Sens.*, in review.

Presentations:

Ding, Y., A. Ignatov, M. Grossberg, I. Gladkova, and C. Chu: Toward Regional Validation and Potential Enhancements to NOAA Polar SST Products, SPIE, Apr. 2016, Baltimore, MD (Oral).

Ding, Y., A. Ignatov, M. Grossberg, I. Gladkova, and C. Chu: Toward Regional Validation and Potential Enhancements to NOAA Polar SST Products, 17th GHRSSST meeting, Jun. 2016, Washington, D.C. (poster).

Ding, Y., I. Gladkova, F. Shahriar, B. Petrenko, A. Ignatov, and Y. Kihai: ACSPO VIIRS L3U version 2 SST product, 17th GHRSSST meeting, Jun. 2016, Washington, DC (Poster).

Ding, Y., I. Gladkova, A. Ignatov, B. Petrenko, Y. Kihai, F. Shahriar, ACSPO VIIRS L3U SST Product, 2016 JPSS Annual Mtg., 8-12 Aug 2016, College Park, MD (Oral).

Ding, Y., A. Ignatov, M. Grossberg, I. Gladkova, C. Chu, Towards Regional Validation and Potential Enhancements to VIIRS SST Product, 2016 JPSS Annual Mtg., 8-12 Aug 2016, College Park, MD (Oral).

Ignatov, A., B. Petrenko, Y. Kihai, M. Kramar, I. Gladkova, P. Dash, X. Liang, X. Zhou, Y. Ding, K. He, J. Stroup, J. Sapper, Current Status and Future Enhancements to ACSPO SST Products at NOAA, 17-21 April 2016, Baltimore, MD (Oral).

Ignatov, A., Y. Kihai, B. Petrenko, I. Gladkova, M. Kramar, X. Zhou, Y. Ding, J. Sapper, NOAA ACSPO SST Products, GHRSSST XVII, 6-10 June 2016, Washington, DC (Oral).

Ignatov, A., B. Petrenko, Y. Kihai, M. Kramar, I. Gladkova, P. Dash, X. Liang, X. Zhou, Y. Ding, K. He, J. Stroup, J. Sapper, Enterprise SST Products at NOAA, 2016 Living Planet Symposium, 9-14 May 2016, Prague, Czech Republic. (Oral.)

Ignatov, A., B. Petrenko, I. Gladkova, Y. Kihai, Y. Ding, X. Zhou, K. He, P. Dash, X. Liang, JPSS SST STAR Progress Report, 2016 JPSS Annual Mtg., 8-12 Aug 2016, College Park, MD (Oral.)

PROJECT TITLE: NESDIS Environmental Applications Team (NEAT) and NEAT Expansion, Suryakanti Dutta, Research Associate - JCSDA Observing System Assessment Standing Capability

PRINCIPAL INVESTIGATORS: Steve Miller, Clifford Matsumoto

RESEARCH TEAM: Suryakanti Dutta and Stephanie Guedj

NOAA TECHNICAL CONTACT: Thomas Auligne, Director, JCSDA; James. G. Yoe, Chief Administrative Officer, JCSDA

NOAA RESEARCH TEAM: N/A

FISCAL YEAR FUNDING (NEAT Total): \$2,104,544

PROJECT OBJECTIVE:

- 1--Implementation of new infrastructure for performing comprehensive OSE "on demand".
- 2--Porting of 4D-EnVar on the new environment designed for JCSDA.
- 3--Generation of statistically significant results from a single case-study.
- 4--Data Denial and addition experiments to study Observation memory and evaluate the impact of GPS-RO and AMSU-A on analysis and forecast skills.

PROJECT ACCOMPLISHMENTS:

1--Completion of the preliminary work needed for implementation of operational OSE's:
In the first phase of work, it was required to define resources needed to implement a robust operational Observing System Assessment Standing Capability for extreme events. One part of this preparation needed to decide over the resolution of the NWP model (both analysis and the forecast) and the HPC system for optimal use of the resources available. Resolution sensitivity experiments were conducted for impact assessment of the model resolution over forecast skill at both global and regional scale. Machine sensitivity tests were also performed by comparing the results simulated on three different HPC systems.

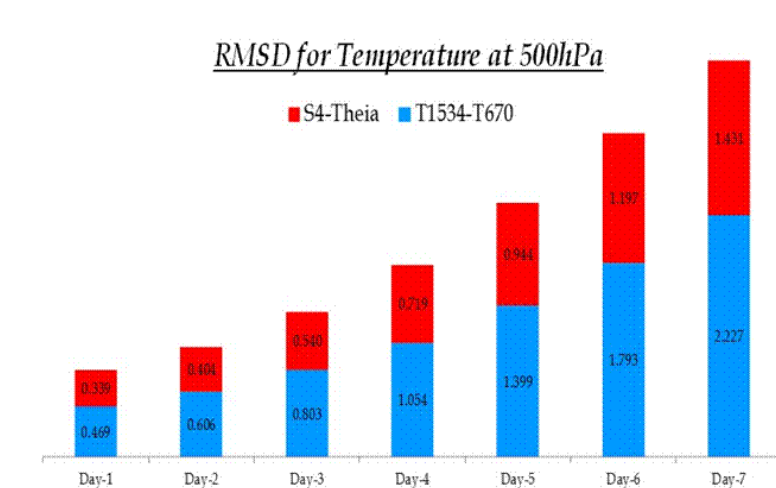

- Blue Bar corresponds to the RMSD from Resolution Sensitivity Experiment.
- Red Bar corresponds to the RMSD from Machine Sensitivity Experiment (S4 vs. Theia)

2—Porting and testing of 4Den-Var (GSI/GFS) in the NASA HPC 'DISCOVER':
 4D-EnVar (GSI / GFS) codes of version 13.0.1 and latest version 13.0.4 are ported in the NASA HPC 'DISCOVER'. These codes have been tested in the resolutions of GFS-T670/GSI-T254 and GFS-T1534/GSI-T574. The codes are running stable. The results have been validated.

3--Preliminary investigation on GPSRO impacts on 3D-EnVar:
 Two separate experiments were performed.

i--First experiment highlighted the observation memory in the 3D-EnVar system and the probable impact on the analysis.

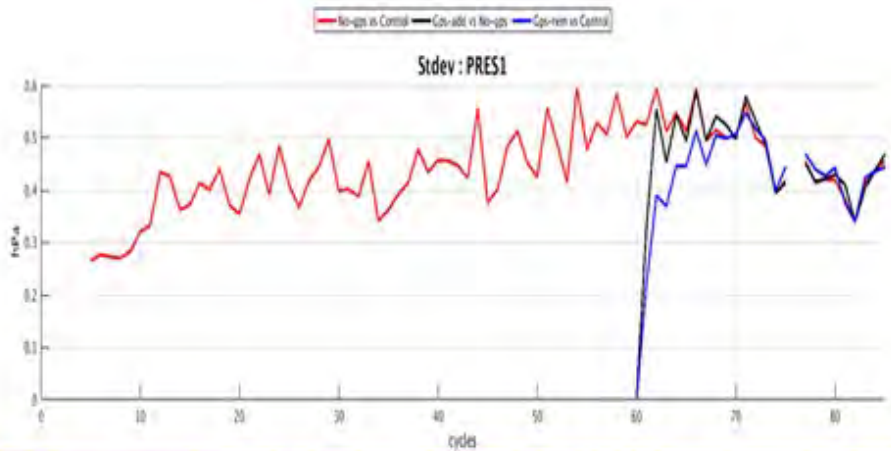

⇒ 10 cycles are need to converge to the "original" atmospheric state (valid for almost all parameters: TMP, HGT, U, V)...

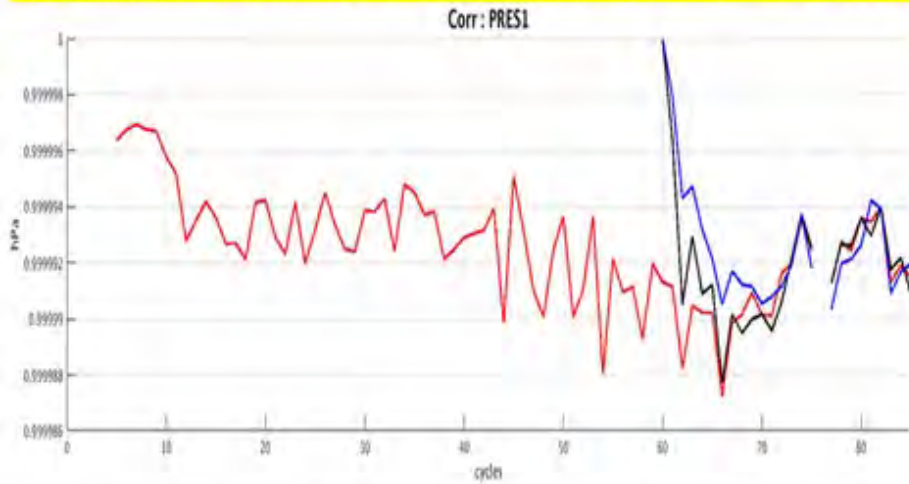

Time-Series of 6h Analysis: Standard Deviation and Correlation for Surface Pressure (hPa).

Impact of GPS-RO Denial

6h-Analysis Bias profiles of HGT (gpm) changes when GPS-RO are removed

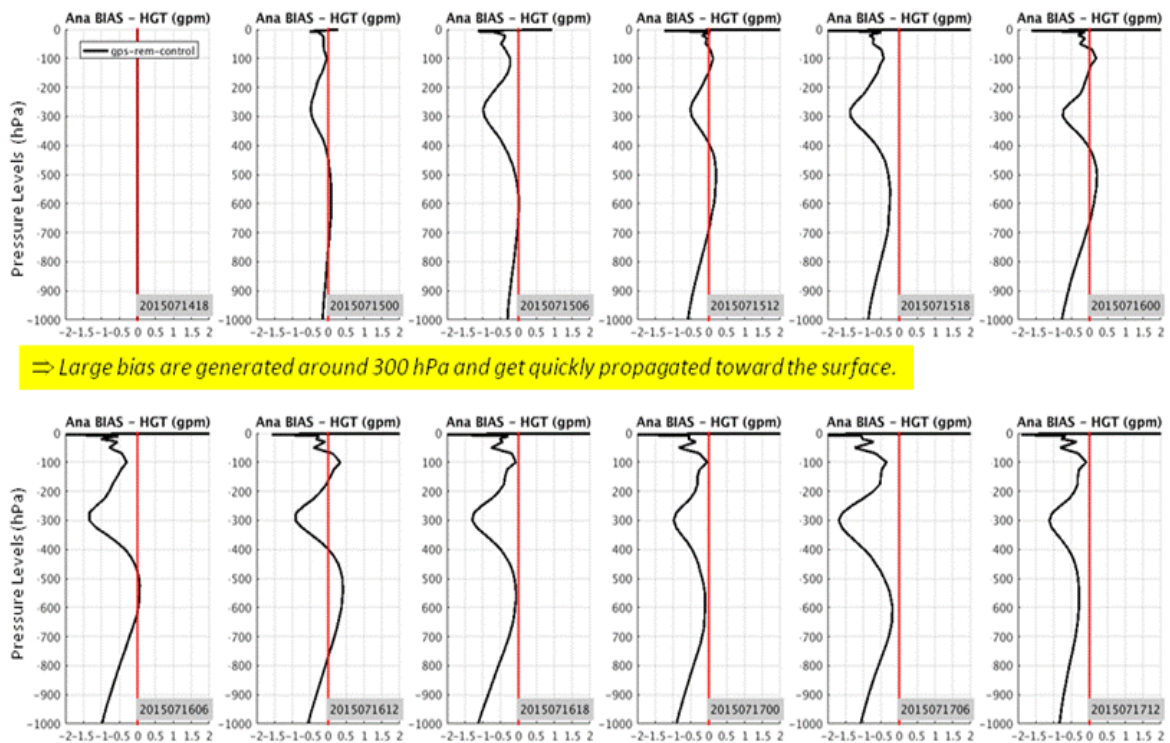

ii--Second experiment highlighted the impact of GPSRO data over the severe weather event Monster Storm – 2016 (Snow Storm). Two simulations were made: Control run and the GPSRO denied Experiment run. The effect of denying GPSRO data over the simulation of the snow storm was analyzed. Verification showed impact corresponding to bias, anomaly correlation and RMSE better cited over mid to upper atmosphere. Near the surface relative humidity and temperature at 2m remains un-affected. Precipitable water (gm/m^2) content is found to have higher values simulated without the GPSRO data assimilated

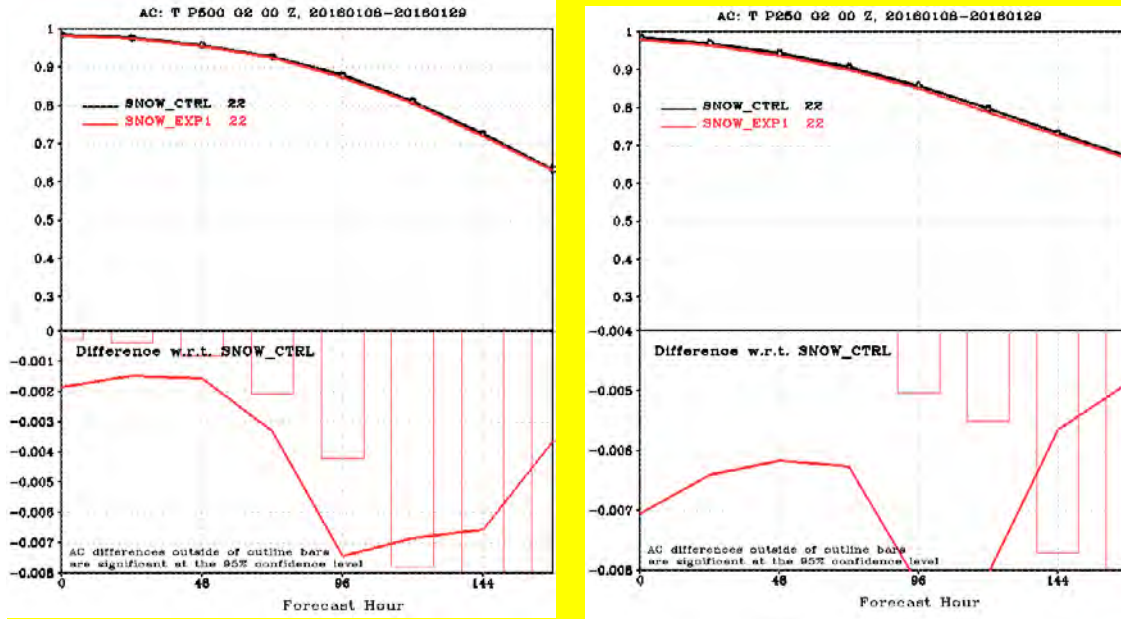

Temperature Anomaly Correlation at 500 and

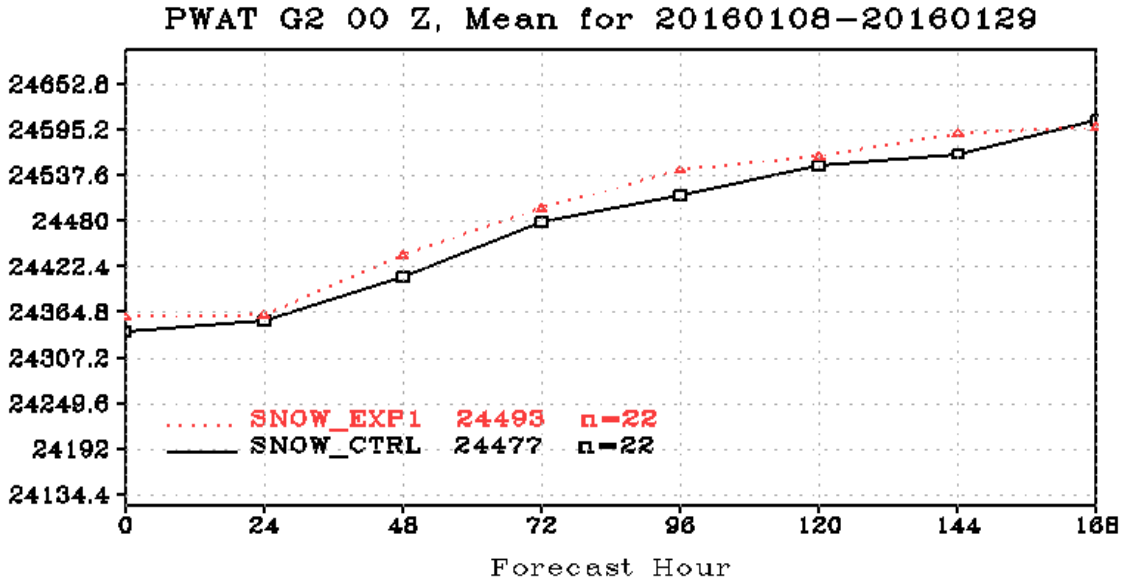

Mean Precipitable Water (gm/m^2) over the Globe.

4—Test cycles with Observation Perturbation in GSI & Ensemble Data Assimilation

The second phase of work required developing a system for generating statistically significant results from a single case of an extreme weather event. Ensemble Data Assimilation (EDA) is the first step towards this goal. For EDA observation perturbation is required in the Global Data Assimilation cycles. Test cycles were conducted to test the observation perturbation individually. Only the conventional observation types were perturbed. Satellite winds are filtered out from perturbation due to their large observation errors. Satellite radiance also remains unperturbed.

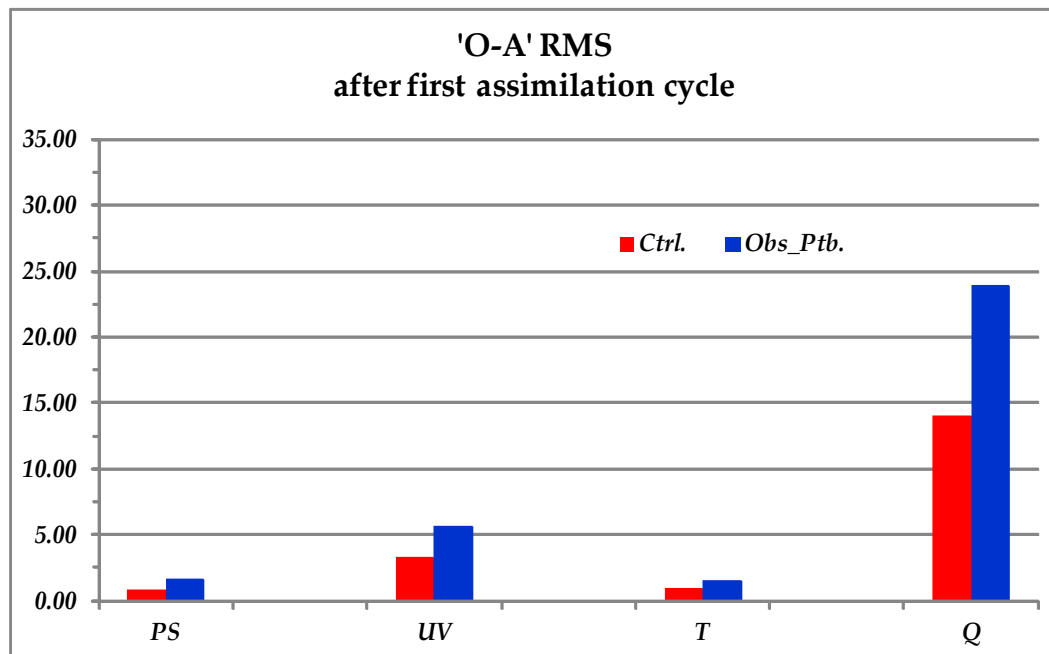
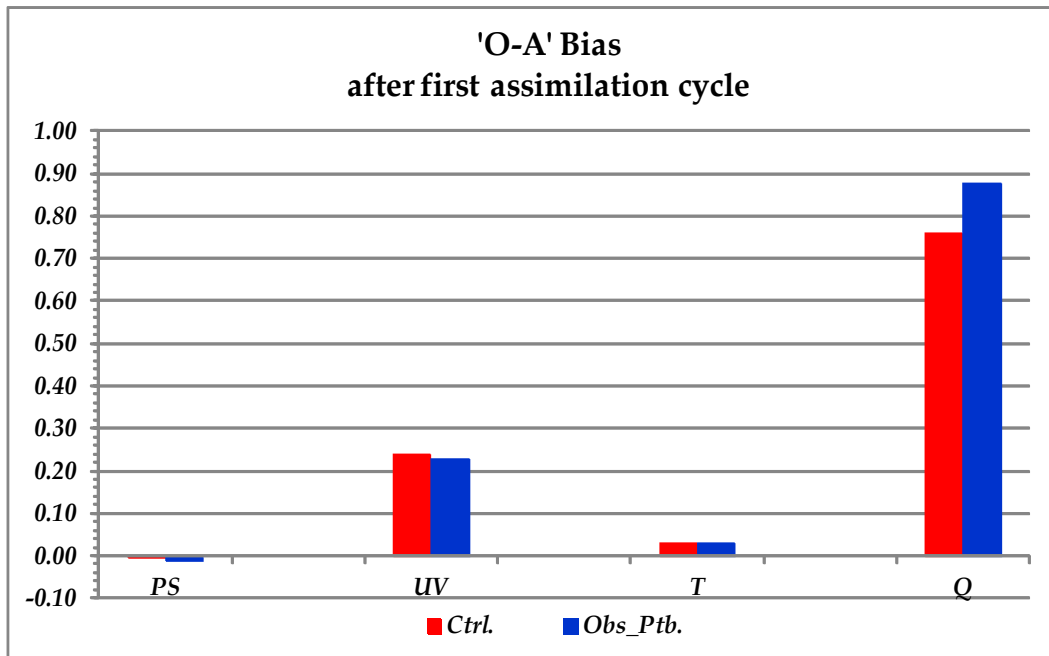

For Ensemble Data Assimilation, 10 members from Hybrid EnKF are considered as first guess for the GSI analysis. 10 individual analyses and subsequently 9 hour forecasts from each analysis are made for initiating the assimilation cycle.

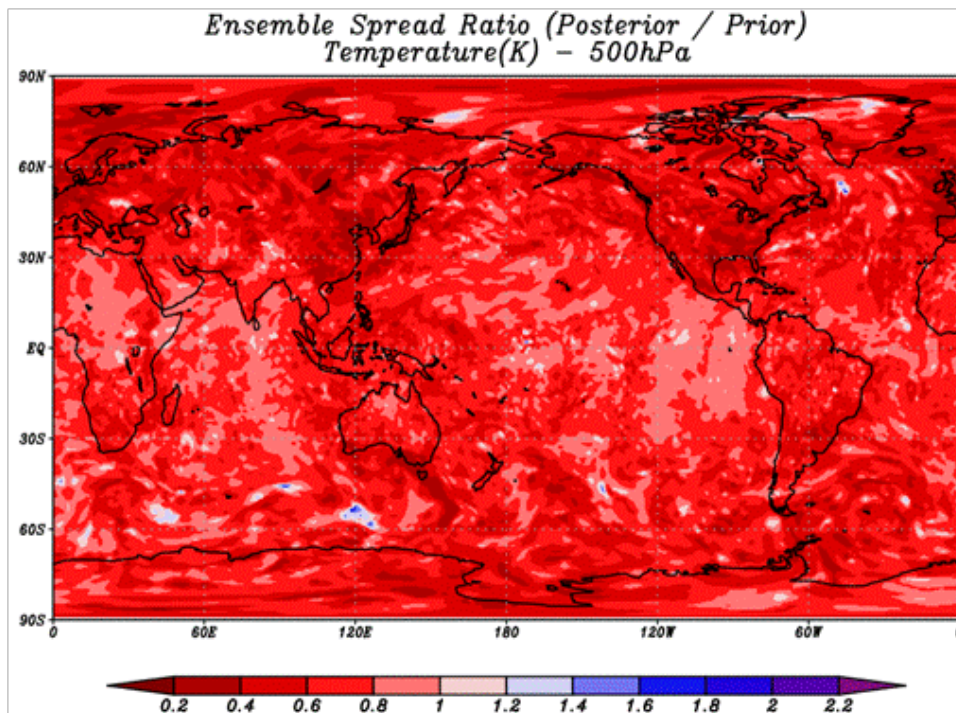
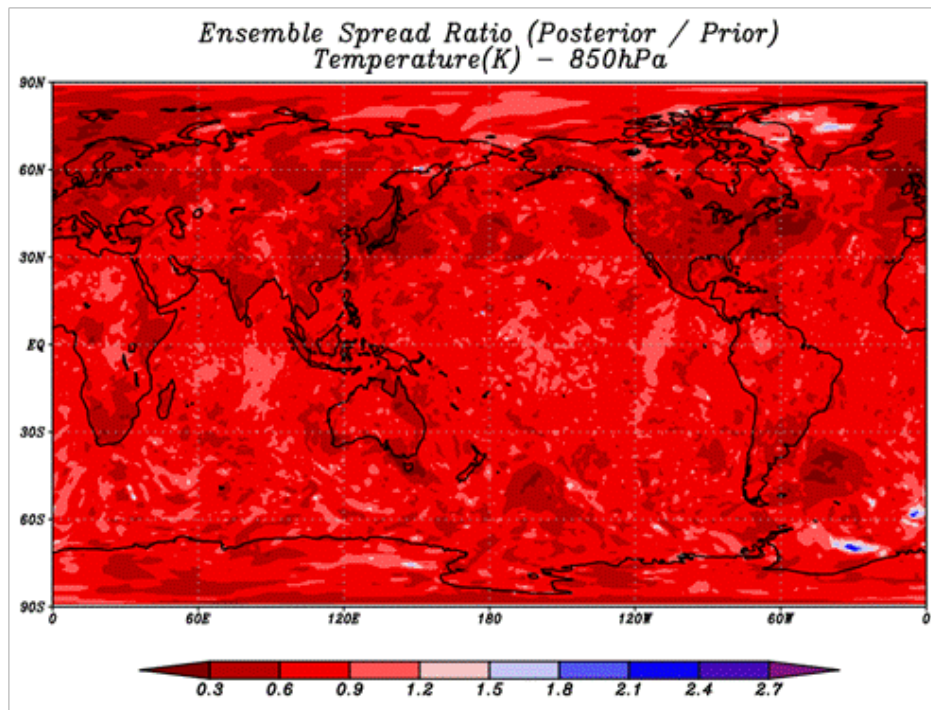

Publications:

Guedj, Stephanie, Suryakanti Dutta, David Groff and Thomas Auligne, 2017: 'JCSDA Observing System Assessment Standing Capability Development (JOSASC), 97th AMS Annual Meeting, Seattle, January 22-26, 2017.

PROJECT TITLE: NESDIS Environmental Applications Team (NEAT) and NEAT Expansion, Lide Jiang, Research Scientist

PRINCIPAL INVESTIGATORS: Steve Miller, Cliff Matsumoto

RESEARCH TEAM: Lide Jiang

NOAA TECHNICAL CONTACT: Menghua Wang, STAR/SOCD/MECB

NOAA RESEARCH TEAM: Menghua Wang

FISCAL YEAR FUNDING (NEAT Total): \$2,104,544

PROJECT OBJECTIVES:

- 1--JPSS NPP VIIRS project support, including VIIRS ocean color Level-1 -> Level-2 -> Level-3 data processing, reprocessing and distribution
- 2--Implement new and improved ocean color algorithms in MSL12 and apply them to ocean color related studies
- 3--Implement new sensor processing capability in MSL12 and produce ocean color products
- 4--COMS GOCI ocean color data application study - surface current derivation with feature tracking method
- 5--Near-real-time and science quality ocean color data support

PROJECT ACCOMPLISHMENTS:

- 1--JPSS NPP VIIRS project support, including VIIRS ocean color Level-1 -> Level-2 -> Level-3 data processing, reprocessing and distribution:
- 1.1--Implemented I-band high/low resolution processing capability for VIIRS-SNPP in MSL12 (Fig.1);
 - 1.2--Identified and resolved another polarization correction bug for VIIRS-SNPP ocean color EDR in MSL12;
 - 1.3--Identified and resolved the missing NO₂ absorption issue for VIIRS-SNPP ocean color EDR in MSL12;
 - 1.4--Updated OCI chlorophyll merging algorithm and related coefficients for VIIRS-SNPP in MSL12;
 - 1.5--Began the routine of daily generation of science quality VIIRS ocean color data based on STAR ocean color team's calibration;
 - 1.6--Finished the second VIIRS-NPP whole mission reprocessing with newest MSL12 package.

1.7--Develop an online tool to monitor F-factor and F-factor ratio for various versions of ocean color SDR and IDPS SDR of VIIRS-SNPP;

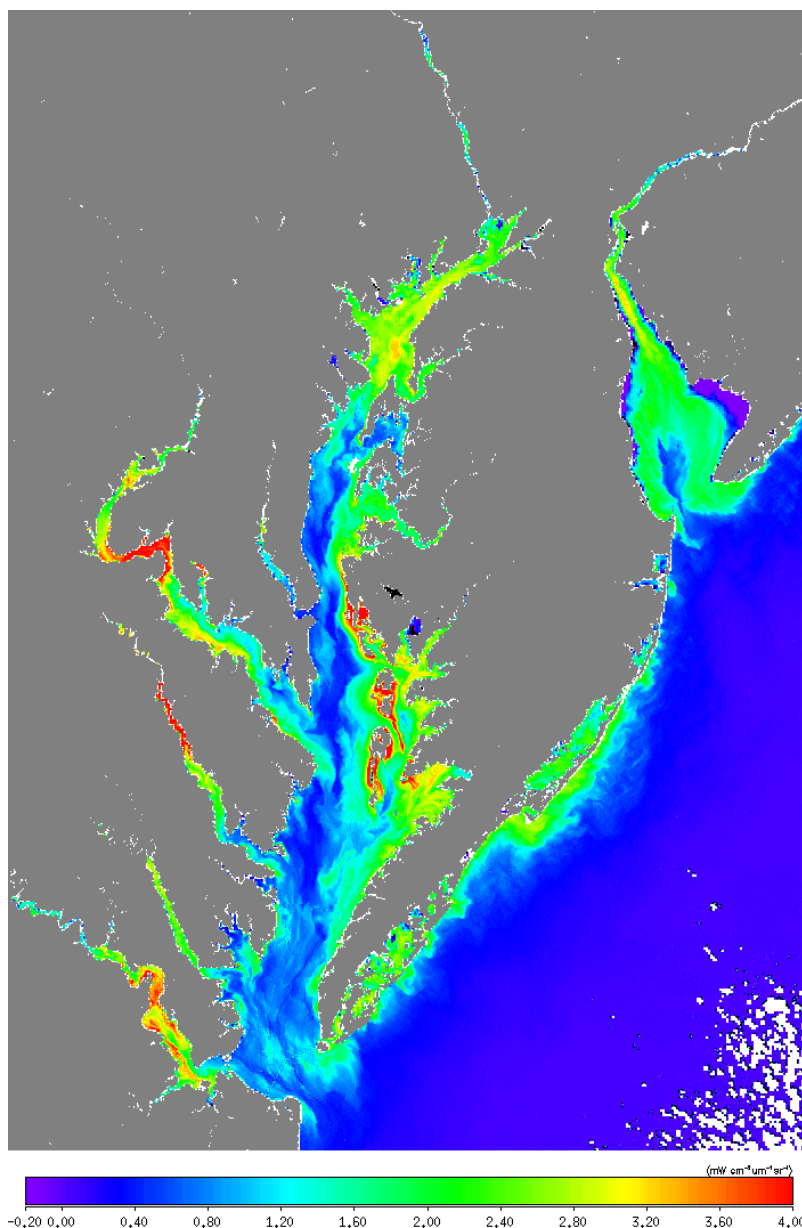

Figure 1. VIIRS I1 band normalized water-leaving radiance nLw(638) in Delmarva region on April 3, 2016 at 18:01 UTC.

2--Implement new and improved ocean color algorithms in MSL12 and apply them to ocean color related studies:

2.1--Implemented Sensor-independent LUTs for diffusive transmittance, Rayleigh reflectance and aerosol phase function for MSL12;

2.2--Integrated GOCI/COMS processing capability into MSL12;

2.3--Integrated OLCI/Sentinel-3 processing capability into MSL12;

2.4--Integrated OLI/Landsat8 processing capability into MSL12;

2.5--Updated sensor files for the above new sensors with more accurate relative spectral response (RSR) weighted Rayleigh optical thickness, water absorption and backscattering

2.6--Implemented a new atmospheric processing scheme for OLCI: NIR+SWIR BMW

2.7--Enable NIR/SWIR atmospheric correction band specification through parameter file for MSL12;

2.8--Implemented epsilon-corrected atmospheric correction for pixels with negative short-wavelength nLws;

2.9--Implemented Rayleigh optical thickness variation with latitude-dependent gravity into MSL12;

3--COMS GOCI ocean color data application study - surface current derivation with feature tracking method

3.1--Retrieve diurnal hourly current maps (Fig.2) in Bohai Sea from GOCI Kd(490) product using Maximum Cross-Correlation feature tracking method and evaluate its performance using in-situ measurement and modeled data;

3.2--Revise the manuscript, which was accepted by IEEE Transactions on Geoscience & Remote Sensing.

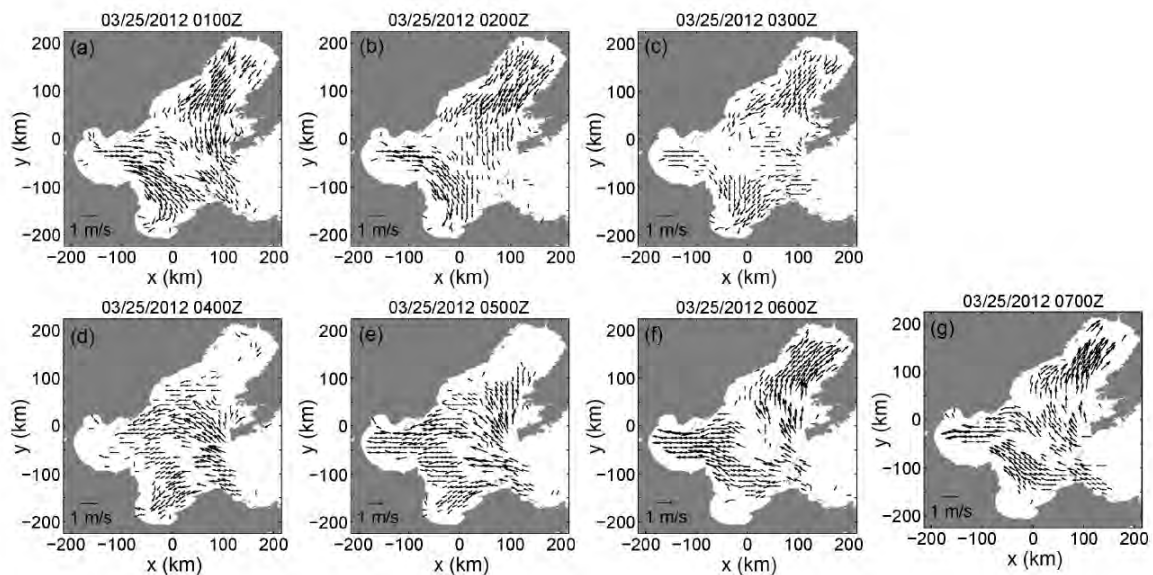

Figure 2 (a)–(g). GOCI-derived diurnal hourly current maps in the Bohai Sea during 01:00–07:00 UTC on March 25, 2012. Vectors are sampled 2:1 for better presentation.

4--Near-real-time and science quality ocean color data support

4.1--Provided science quality VIIRS Level-2 ocean color data in support of the Cal/Val Team members including Chuanmin Hu from University of South Florida and Robert Arnone from University of Southern Mississippi

4.2--Provided NOAA Coral Reef Watch with regional Level-3 data in mapped format (converted from binned format) near coral reef sites including Puerto Rico, Great Barrier Reef, American Samoa, Hawaii and Southwest Pacific.

Publications:

Jiang, L. and M. Wang, "Diurnal currents in the Bohai Sea derived from the Korean Geostationary Ocean Color Imager", IEEE Trans. Geosci. Remote Sens., 55, 1437-1450 (2017).
doi:10.1109/TGRS.2016.2624220this link opens in a new window

Wang, M., W. Shi, **L. Jiang**, and K. Voss, "NIR- and SWIR-based on-orbit vicarious calibrations for satellite ocean color sensors", *Opt. Express*, 24, 20437-20453 (2016). doi:10.1364/OE.24.020437

Wang, M., **L. Jiang**, X. Liu, S. Son, J. Sun, W. Shi, L. Tan, K. Mielsons, X. Wang, and V. Lance, "VIIRS ocean color products: A progress update", *Proc. IGARSS '16*, pp.5848-5851 (2016). doi:10.1109/IGARSS.2016.7730528

PROJECT TITLE: NESDIS Earth Applications Team – Shuyan Liu, Research Scientist -Tropical Cyclone Model Diagnostics and Product Development

PRINCIPAL INVESTIGATORS: Steve Miller, Cliff Matsumoto

RESEARCH TEAM: Shuyan Liu

NOAA TECHNICAL CONTACT: Quanhua Liu, NOAA/NESDIS/STAR

NOAA RESEARCH TEAM: Christopher Grassotti, Cooperative Institute for Climate and Satellites-MD/Earth System Science Interdisciplinary Center, University of Maryland

Junye Chen, Cooperative Institute for Climate and Satellites-MD/Earth System Science Interdisciplinary Center, University of Maryland

FISCAL YEAR FUNDING (NEAT Total): \$2,104,544

PROJECT OBJECTIVES:

- 1--Developing, extending, improving, and validating all data products from MiRS
- 2--Managing the MiRS software and website.

PROJECT ACCOMPLISHMENTS:

- 1--Validated MiRS retrieved rain rate by NCEP Stage-IV rain rate data.
- 2--Validated MiRS retrieved Cloud Liquid Water by GPROF GPM data.
- 3--Upgraded the products publishing on MiRS website at daily basis from V11.1 to V11.2.

Publications:

Ferraro R., P. Meyers, P. Chang, Z. Jelenak, C. Grassotti, and **Liu S.**, 2017: Application of GCOM-W AMSR2 and S-NPP ATMS hydrological products to a flooding event in the United States, *JSTAR special issue*, accepted.

Liu S., C. Grassotti, J. Chen, and Q. Liu, 2017: GPM products from the Microwave Integrated Retrieval System (MiRS), *IEEE Journal of Selected Topics in Applied Earth Observations and Remote Sensing*, under review.

PROJECT TITLE: NESDIS Earth Applications Team – Xiaoming Liu, Research Scientist - Ocean Color Algorithm Development and Ocean Process Study with Satellite Ocean Color Remote Sensing

PRINCIPAL INVESTIGATORS: Steve Miller, Cliff Matsumoto

RESEARCH TEAM: Xiaoming Liu

NOAA TECHNICAL CONTACT: Menghua Wang

NOAA RESEARCH TEAM: Menghua Wang

FISCAL YEAR FUNDING (NEAT Total): \$2,104,544

PROJECT OBJECTIVES:

- 1--Calibration/Validation and monitoring of VIIRS ocean color products
- 2--Conduct ocean color related applications and research

PROJECT ACCOMPLISHMENTS:

- 1--Calibration/Validation and monitoring of VIIRS ocean color products

--Routinely monitored the time series of VIIRS ocean color data products in regions of interests, including Hawaii, South Pacific Gyre, Chesapeake Bay and U.S. east coast regions. The in situ data at four NOAA-funded stations including MOBY, AERONET-CSI, AERONET-LISCO and AERONET-USC, are routinely compared with VIIRS ocean color products. In addition, in situ data from 16 more AERONET ocean color stations around the world (including MVCO, GLORIA, VENICE, BLYTH, COVE, LAKE-ERIE, GALATA, GOT, GUSTAV, HELSINKI, IEODO, LUCINDA, PALGRUNDEN, SOCHEONGCHO, THORNTON, and ZEEBRUGGE) are also recently added to the monitoring system for comparison with VIIRS ocean color data. These processes are automated on our Linux servers and posted on the web weekly. For example, Figure 1 shows updated the time series of ocean color products at Hawaii as an example.

--The VIIRS ocean color products in the global oligotrophic waters and deep waters, which are important to evaluate the VIIRS ocean color calibrations, are continuously monitored. Figure 2 shows the updated time series of nLw(443) (top panel) and nLw(551) (lower panel) in the global oligotrophic waters as examples. The nLw(443) in the global oligotrophic waters has been very stable since the beginning of launch (top panel). However, a significant downward trend in the nLw(551) based on IDPS SDR (purple line lower panel) can be seen clearly. In comparison, the nLw(551) based on science quality Ocean Color SDR (blue line) are significantly improved. The global mean of ocean color products in the global oligotrophic waters and deep waters are very sensitive to VIIRS calibrations, and the anomalies in the calibration can be detected from the time series of the global mean. The global monitoring process are automatically generated on Linux server and put on the web server for online access. In web interface was also significantly improved for more user friendly interaction.

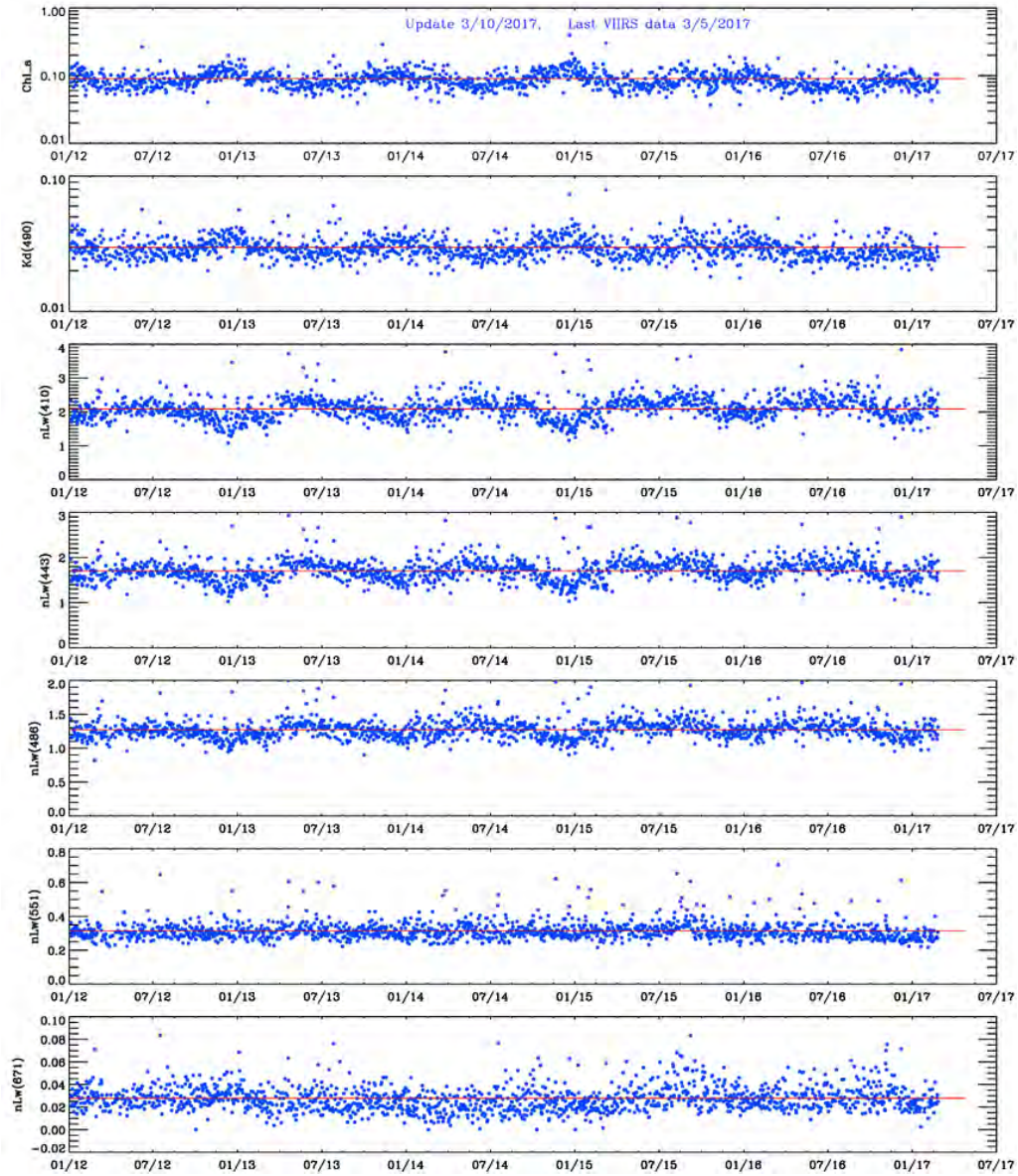

Figure 1. Near-real-time monitoring of VIIRS ocean color data of the Hawaii region. (<http://www.star.nesdis.noaa.gov/sod/mecb/color/CalVal.php>).

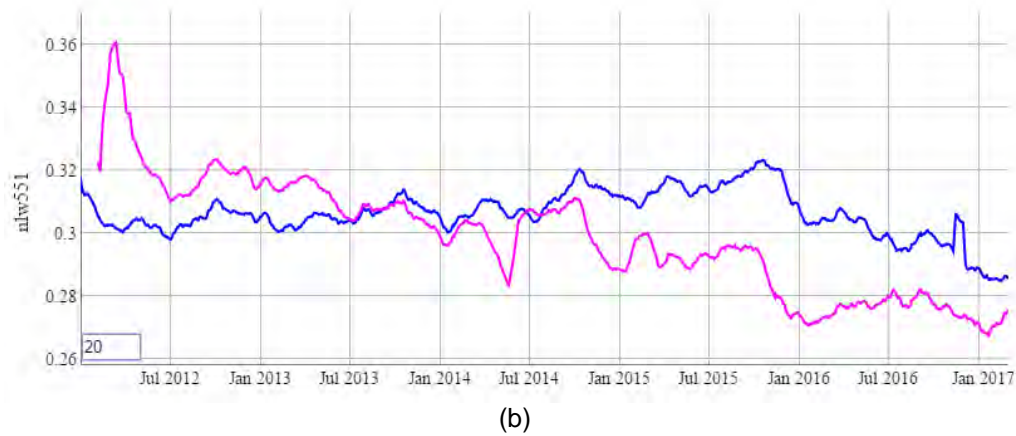
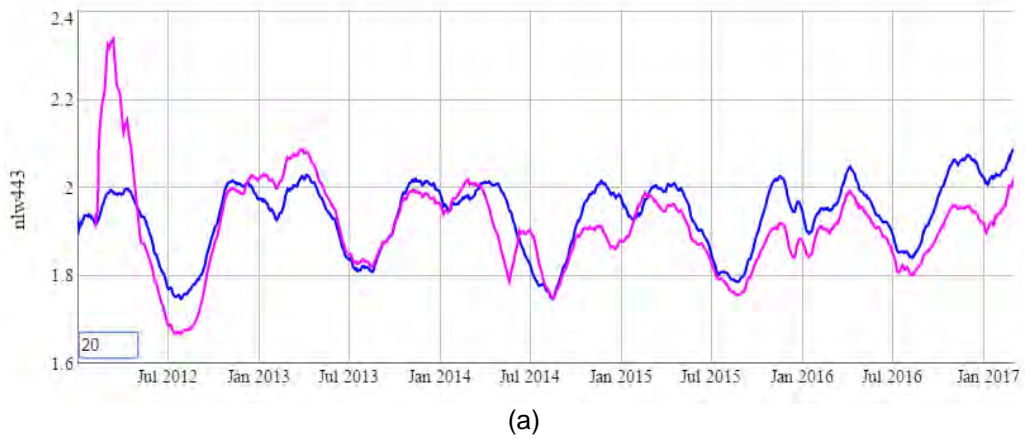

Figure 2. Time series of (a) nLw(443) (top panel) and (b) nLw(551) (lower panel) in the global oligotrophic waters for VIIRS science quality data stream (blue lines) and near-real-time data stream (purple lines).

--VIIRS ocean color products in global oligotrophic waters are also compared with those derived from MODIS. Figure 3 shows the time series of VIIRS ocean color products (blue) compared with those from MODIS-Aqua (red) over global oligotrophic waters using the 8-day global 9-km Level-3 file from 2012 to 2016. Figures 3(a)–3(d) are VIIRS-MODIS comparisons for ocean color products of $nL_w(443)$, $nL_w(551)$, Chl-a, and $K_d(490)$, respectively, over global oligotrophic waters. It is particularly noted that VIIRS and MODIS have very close spectral bands for 443 nm and 551 nm, and thus both $nL_w(443)$ and $nL_w(551)$ should be comparable for VIIRS and MODIS. In general, VIIRS ocean color products are in good agreement with those of MODIS in the global oligotrophic waters. For $nL_w(443)$, VIIRS has been very stable since 2012, but MODIS shows a slightly downward trend from 2012 to 2015, which could be due to the sensor degradation in MODIS blue bands. $nL_w(551)$ times series are very flat for both VIIRS and MODIS. The Chl-a and $K_d(490)$ time series are consistent in seasonal variations, and are very stable from 2012 to 2015 for both VIIRS and MODIS, but they both drop significantly in 2016, for which the cause needs to be further investigated.

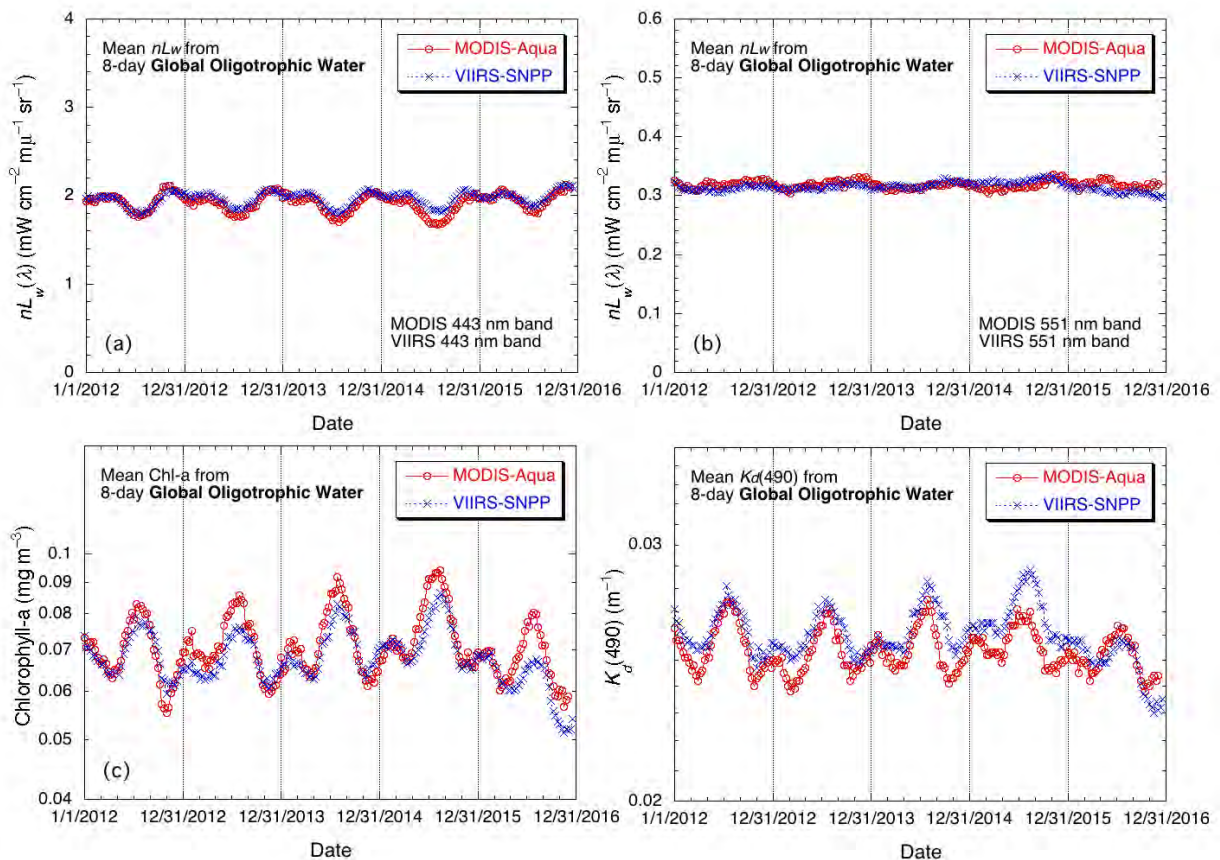

Figure 3. Time series of VIIRS ocean color products (blue) compared with those from MODIS Aqua (red) over global oligotrophic waters with 8-day mean values for ocean color products of (a) $nL_w(443)$, (b) $nL_w(551)$, (c) Chl-a, and (d) $K_d(490)$.

--Prepared VIIRS ATBD: Menghua Wang, Xiaoming Liu and Lide Jiang, "THE VIIRS OCEAN COLOR PRODUCT ALGORITHM THEORETICAL BASIS DOCUMENT", VERSION 1.0, NOAA/NESDIS/STAR, March 1, 2017

2--Conduct ocean color related applications and research

--Liu, X. and M. Wang, "Analysis of ocean diurnal variations from the Korean Geostationary Ocean Color Imager measurements using the DINEOF method", *Estuarine Coastal Shelf Sci.*, 180, 230-241 (2016). doi:10.1016/j.ecss.2016.07.006

Abstract: High-frequency images of the water diffuse attenuation coefficient at the wavelength of 490 nm ($K_d(490)$) derived from the Korean Geostationary Ocean Color Imager (GOCI) provide a unique opportunity to study diurnal variation of the water turbidity in coastal regions of the Bohai Sea, Yellow Sea, and East China Sea. However, there are lots of missing pixels in the original GOCI-derived $K_d(490)$ images due to clouds and various other reasons. Data Interpolating Empirical Orthogonal Function (DINEOF) is a method to reconstruct missing data in geophysical datasets based on Empirical Orthogonal Function (EOF). It utilizes both temporal and spatial coherencies of data to infer a solution at the missing locations. In this study, the DINEOF is applied to GOCI-derived $K_d(490)$ data in the Yangtze River mouth and the Yellow River mouth regions, and the DINEOF reconstructed $K_d(490)$ data are used to fill in the missing pixels. In fact, DINEOF had been used to fill in the gaps in ocean color chlorophyll-a and turbidity data from the Sea-viewing Wide Field-of-View Sensor (SeaWiFS), Moderate Resolution Imaging Spectroradiometer (MODIS), and Spinning Enhanced Visible and InfraRed Imager (SEVIRI) in previous studies. Our GOCI validation results show that the bias between the reconstructed data and the original $K_d(490)$ value is quite small ($< \sim 5\%$). The standard deviation of the reconstructed/original ratio is ~ 0.25 and ~ 0.30 for the mouths in the Yangtze River and Yellow River, respectively. In addition, GOCI high temporal resolution measurements in $K_d(490)$ can capture sub-diurnal variation due to the tidal forcing. The spatial patterns and temporal functions of the first three EOF modes are also examined. The first EOF mode characterizes the general mean spatial distribution of the region, while the second and the third EOF modes represent the variations due to the tidal forcing in the region.

Publications:

Liu, X. and M. Wang, "Reconstruction of Missing Pixels in VIIRS Ocean Color Images Using the Data Interpolating Empirical Orthogonal Function (DINEOF)", *Ocean Optics XXIII*, October 2016, Victoria, BC, Canada

Wang, M., L. Jiang, X. Liu, S. Son, J. Sun, W. Shi, L. Tan, K. Mielsons, X. Wang, and V. Lance, "VIIRS ocean color products: A progress update", *Proc. IGARSS '16*, pp.5848-5851 (2016). doi:10.1109/IGARSS.2016.7730528

PROJECT TITLE: NESDIS Environmental Applications Team, Zhiyong Liu, Post Doc - Noise Estimation in NOAA SST products

PRINCIPAL INVESTIGATORS: Steve Miller, Cliff Matsumoto

RESEARCH TEAM:

NOAA TECHNICAL CONTACT: Alexander Ignatov

NOAA RESEARCH TEAM: Zhiyong Liu, Alexander Ignatov, Irina Gladkova, Yury Kihai

FISCAL YEAR FUNDING (NEAT Total): \$2,104,544

PROJECT OBJECTIVE:

The aim of this project is to evaluate noise level in different SST products produced by NOAA from SNPP VIIRS, Aqua and Terra MODIS, and MetOp-A and -B AVHRR, using a semi-variogram technique. Estimation of noise in individual SST products is a first step towards their merging and creating collated products.

PROJECT ACCOMPLISHMENTS:

An example semi-variogram is shown in Figure 1.

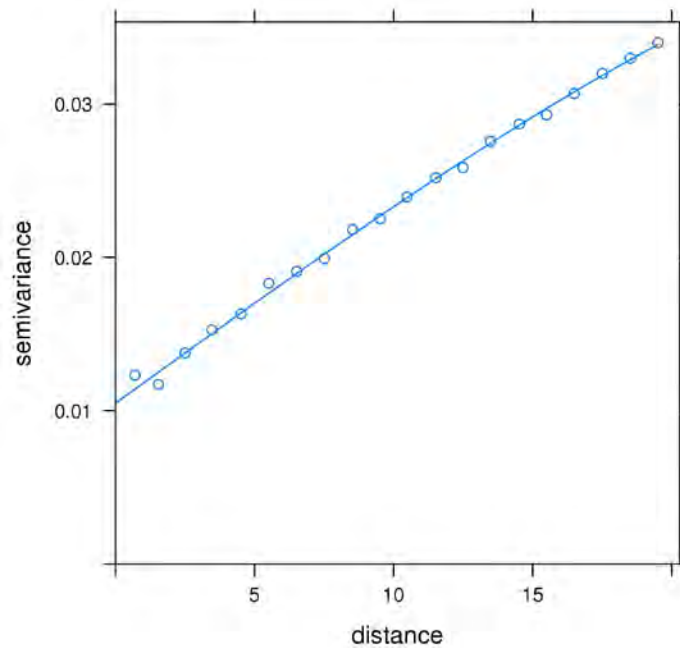

Figure 1. Semi-variogram derived from a 10-min VIIRS daytime granule on 2016-12-02 (daytime) at latitude 0°. Y axis shows semi-variance of VIIRS SST.

If SST noise is zero, the nugget (intercept) is supposed to be zero at zero lag distance. In reality, the nugget variance is always positive, due to noise in SST. Spherical model was used to fit the semi-variogram and estimate the nugget. Linear fits is also being explored, if proves more robust and accurate than any non-linear fits.

Sigma of SST noise (square root of nugget variance) was analyzed as a function of latitude, SST, and satellite view zenith angle (VZA), and compared across platforms, and between daytime and nighttime SST. For each bin of the corresponding dependencies, box-plot was used.

Figures. 2-6 show sigmas as a function of VZA during the daytime. For VIIRS and two MODIS, the curve is U-shaped (concave), suggesting increasing sigmas from nadir towards the swath edge.

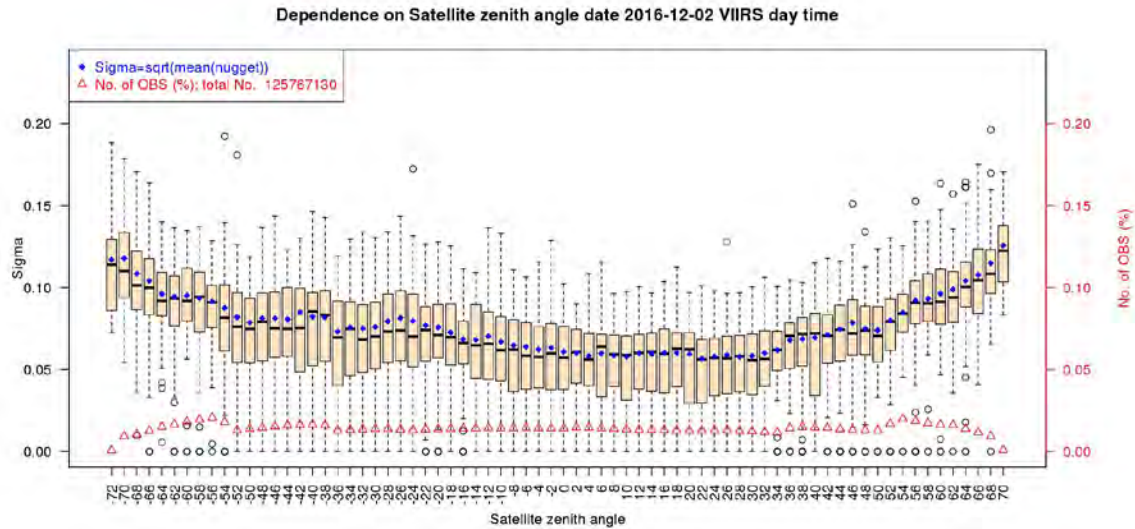

Figure 2. Box plot of the sigma values as a function of satellite view zenith angle for the VIIRS (a), MODIS-aqua (b), MODIS-terra (c), MetOp-A (d), MetOp-B (e) on 2016-12-02 (daytime). The solid lines within the box indicate the median values; the upper and lower boundaries represent the 75th and 25th percentiles; the whiskers above and below the box represent the 90th and 10th percentiles; the blue diamond-shapes indicate the sigmas based on mean nugget values (i.e., mean $\sigma = \sqrt{\text{mean}(\text{nugget})}$); the red triangle-shapes show the number of observations (%).

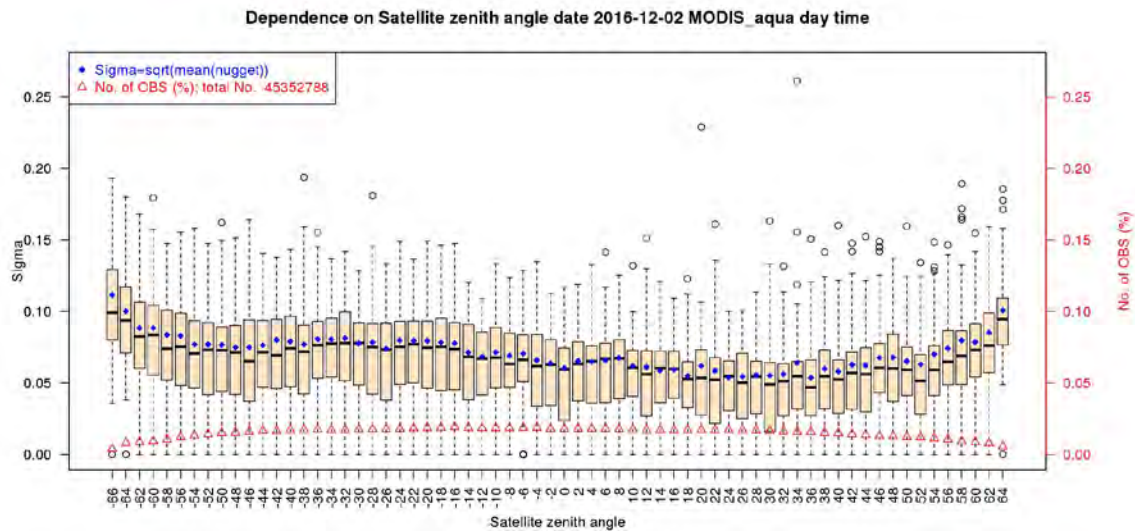

Figure 3. As in Figure 2 but for the MODIS-aqua.

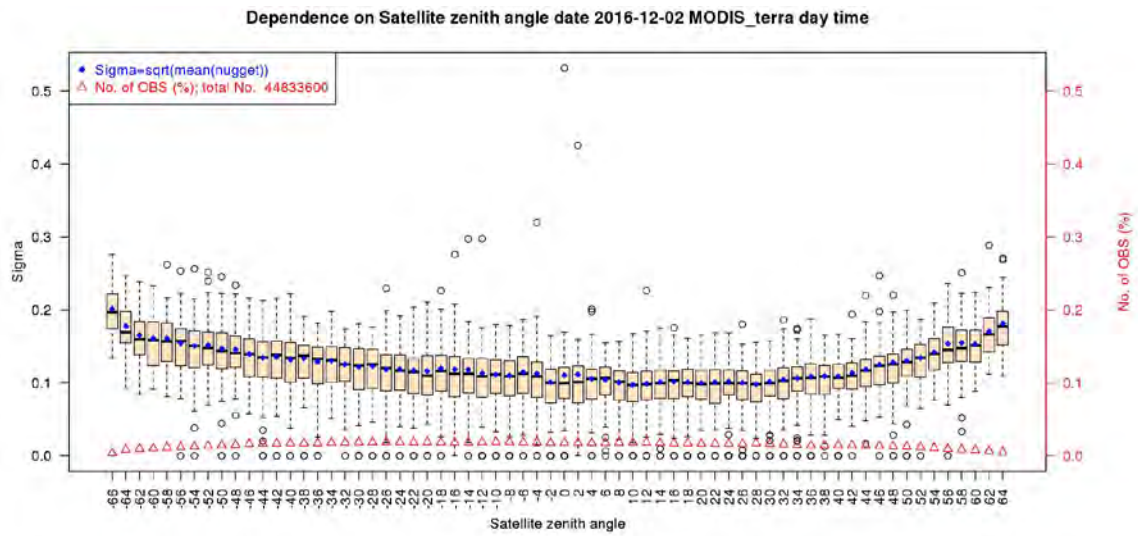

Figure 4. As in Figure 2 but for the MODIS-terra.

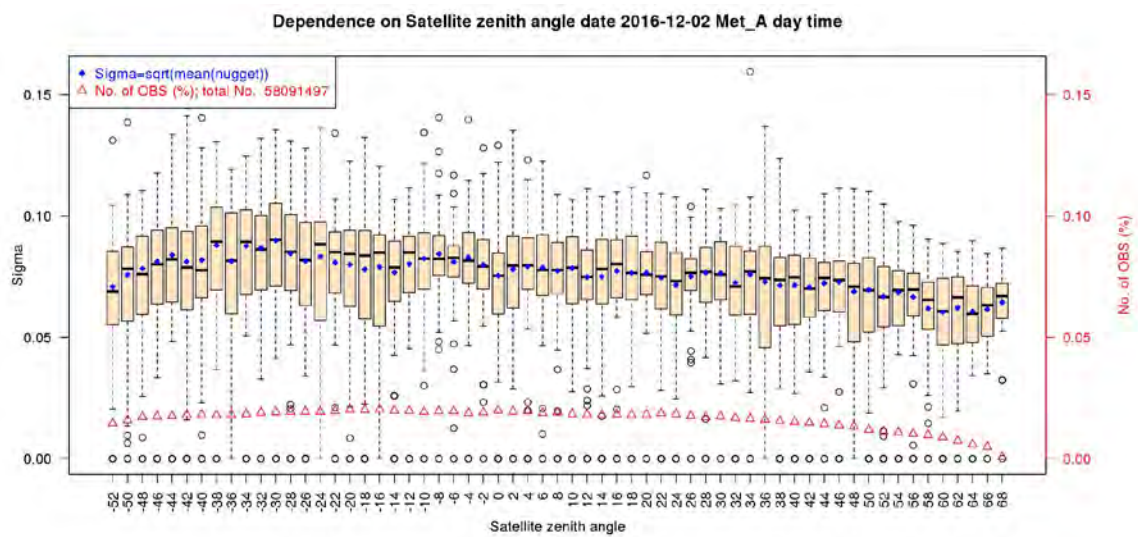

Figure 5. As in Figure 2 but for the MetOp-A.

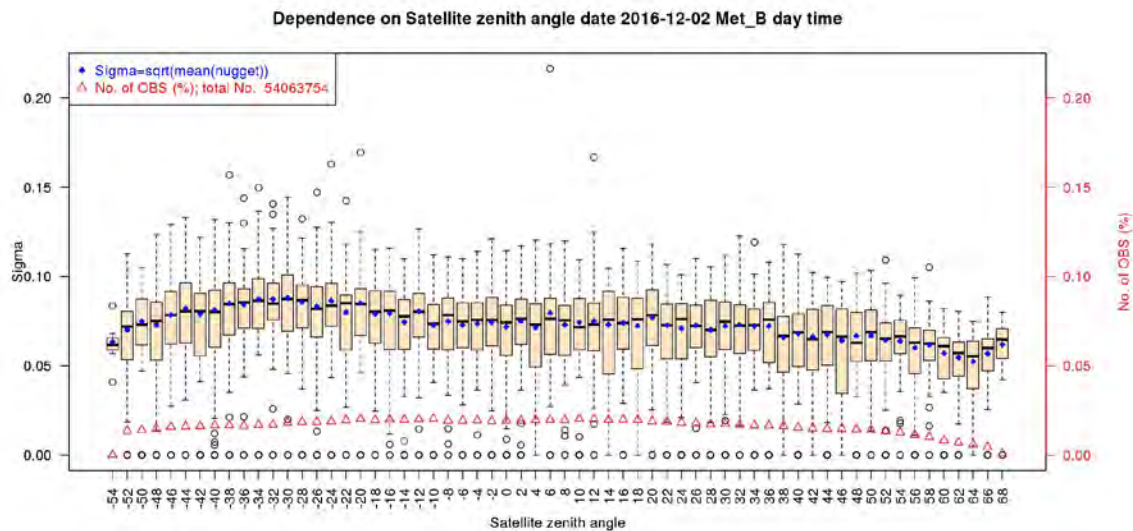

Figure 6. As in Figure 2 but for the MetOp-B .

The increasing trend in sigmas with increasing VZA is expected and is likely related to the use of angular terms employed in the ACSPO nighttime Multichannel SST (MCSST) algorithm. Those terms will amplify the noise in brightness temperatures progressively more towards the swath edge. Also, the discontinuities in sigmas for VIIRS may be related to different aggregation zones and stronger bow-tie distortions. However, the curves for the two MetOp sensors have a convex shape, which is counterintuitive and inconsistent with the expectations. Work is underway to understand the root cause of these results and fix.

PROJECT TITLE: NESDIS Environmental Applications Team, Wei Shi, Research Scientist - NPP VIIRS Calibration and Validation, Ocean Color Algorithm Development and Ocean Process Study with Satellite Ocean Color Remote Sensing

PRINCIPAL INVESTIGATORS: Steve Miller, Cliff Matsumoto

RESEARCH TEAM: Wei Shi

NOAA TECHNICAL CONTACT: Menghua Wang

NOAA RESEARCH TEAM: Menghua Wang

FISCAL YEAR FUNDING (NEAT Total): \$2,104,544

PROJECT OBJECTIVES:

- 1--Development of new satellite ocean color algorithm
- 2--NPP VIIRS calibration and validation
- 3--Application of satellite ocean color data for coastal and in-land water ecosystem monitoring

PROJECT ACCOMPLISHMENTS:

During this period, I conducted research on NIR and SWIR-Based on-orbit vicarious calibrations for satellite ocean color sensors. Research was also conducted to study the stabilization of SNPP VIIRS ocean color products after vicarious calibration. I also conducted the study to derive the total suspended matter concentration from the near-infrared-based inherent optical properties over turbid waters.

--Consistence of the NIR and SWIR-Based On-Orbit Vicarious Calibrations for Satellite Ocean Color Sensors.

--Study of the stabilization of SNPP VIIRS ocean color products after vicarious calibration.

--Derive the vicarious gains for VIIRS ocean color data processing.

--Deriving total suspended matter concentration from the near-infrared-based inherent optical properties over turbid waters: A case study in Lake Taihu.

Publications:

Title: The NIR and SWIR-Based On-Orbit Vicarious Calibrations for Satellite Ocean Color Sensors

Author(s): Shi, Wei; Wang, Menghua

Wang, M., W. Shi, L. Jiang, and K. Voss, "NIR- and SWIR-based on-orbit vicarious calibrations for satellite ocean color sensors", *Opt. Express*, 24, 20437-20453 (2016). doi:10.1364/OE.24.020437

Abstract: The near-infrared (NIR) and shortwave infrared (SWIR)-based atmospheric correction algorithms are both used in satellite ocean color data processing, with the SWIR-based algorithm particularly for the ocean color data processing over turbid coastal and inland waters. In this study, we describe the NIR- and SWIR-based on-orbit vicarious calibration approaches for satellite ocean color sensors, and compare results from these two on-orbit vicarious calibrations using satellite measurements from the Visible Infrared Imaging Radiometer Suite (VIIRS) onboard the Suomi National Polar-orbiting Partnership (SNPP). Vicarious calibration gains for VIIRS spectral bands are derived using the in situ normalized water-leaving radiance $nL_w(\lambda)$ spectra from the Marine Optical Buoy (MOBY) in the waters off Hawaii. The SWIR vicarious gains are determined using VIIRS measurements from the South Pacific Gyre region, where ocean waters are the clearest and generally stable. Specifically, vicarious gain sets for VIIRS spectral bands of 410, 443, 486, 551, and 671 nm derived from the NIR method using the NIR 745 and 862 nm bands, the SWIR method using the SWIR 1238 and 1601 nm bands, and the SWIR method using the SWIR 1238 and 2257 nm bands are (0.979954, 0.974892, 0.974685, 0.965832, 0.979042), (0.980344, 0.975344, 0.975357, 0.965531, 0.979518), and (0.980820, 0.975609, 0.975761, 0.965888, 0.978576), respectively. Thus, the NIR-based vicarious calibration gains are consistent with those from the two SWIR-based approaches, with discrepancies within ~0.1% (mostly within ~0.05%) from three data processing methods. In addition, the NIR vicarious gains (745 and 862 nm) derived from the two SWIR methods are (0.982065, 1.00001) and (0.981811, 1.00000), respectively, with the difference ~0.03% at the NIR 745 nm band. This is the fundamental basis for the NIR-SWIR combined atmospheric correction algorithm, which has been used to derive improved satellite ocean color products over open oceans and turbid coastal/inland waters. Indeed, the difference of the NIR- and SWIR-derived $nL_w(\lambda)$ spectra are negligible after applying the same consistent vicarious calibration gains in the ocean color data processing. Therefore, a unified vicarious gain set for VIIRS bands M1–M8 and M10–M11, i.e., (0.979954, 0.974892, 0.974685, 0.965832, 0.979042, 0.982065, 1.00000, 1.01812, 0.994676, 1.20252), has been implemented in the VIIRS ocean color data processing for routine ocean color production. Using the unified vicarious gain set, VIIRS mission-long ocean color data have been successfully reprocessed using the NIR-, SWIR-, and NIR-SWIR-based atmospheric correction algorithms in the ocean color data processing system.

OCIS codes: (010.0010) Atmospheric and oceanic optics; (010.1285) Atmospheric correction; (010.0280) Remote sensing and sensors; (010.4450) Oceanic optics.

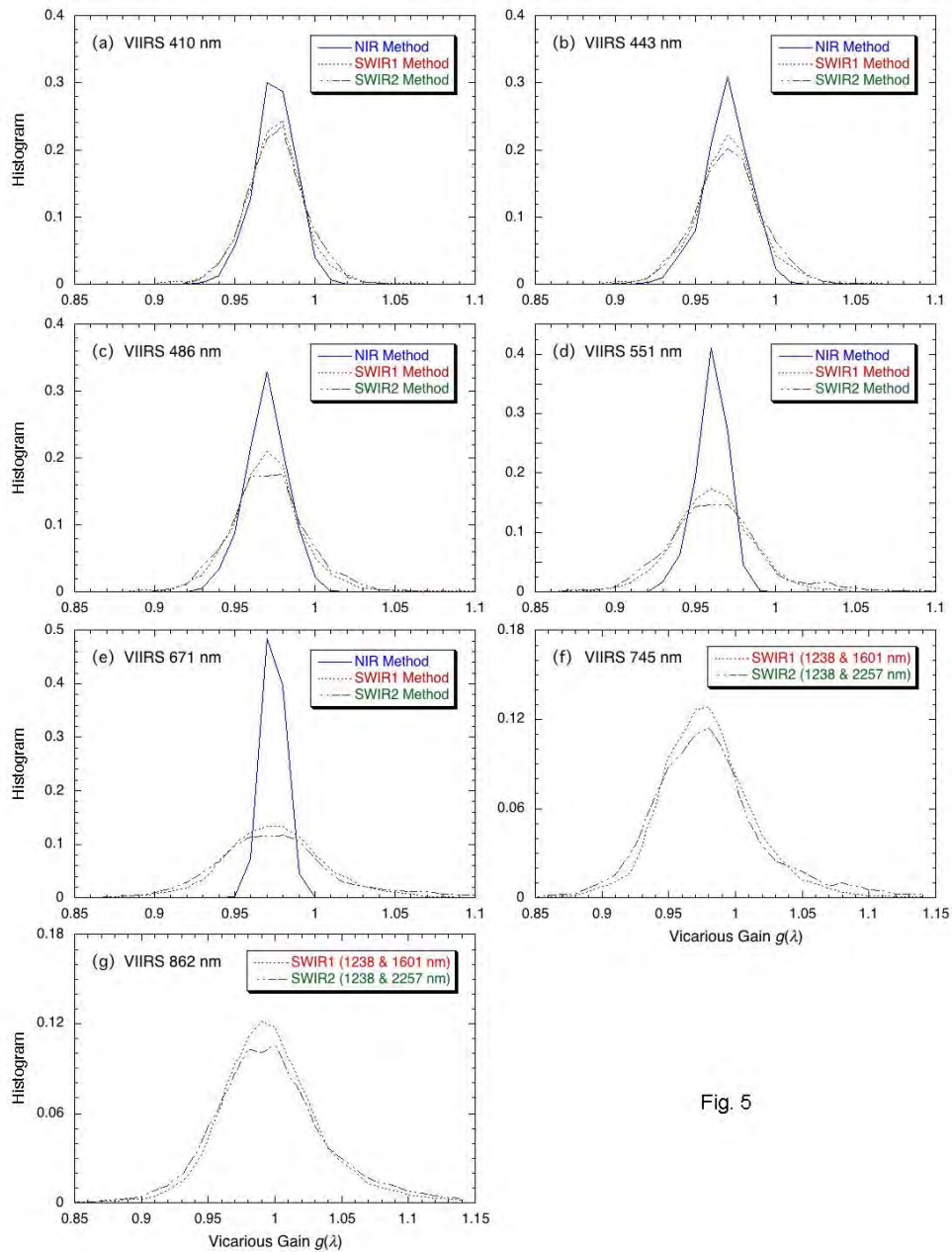

Fig. 5

Figure Caption. Comparisons of histogram results in the derived vicarious gains between using the NIR-based method, SWIR1-based and SWIR2-based methods for VIIRS bands at the wavelength of (a) 410 nm, (b) 443 nm, (c) 486 nm, (d) 551 nm, and (e) 671 nm. Plot (f) and plot (g) show histograms for the SWIR1-based vicarious gains $g^{(SWIR1)}(\lambda)$ and SWIR2-based vicarious gains $g^{(SWIR2)}(\lambda)$ at the VIIRS two NIR bands of 745 nm and 862 nm.

Title: On the stabilization of SNPP VIIRS ocean color products after vicarious calibration
 Author(s): Wang, M., W. Shi **et al.**
In Progress

Abstract: Using matchups between SNPP VIIRS and MOBY *in-situ* data, we compute the time series of accumulated vicarious calibration gains for VIIRS ocean color data processing in 3-month time intervals from NPP launch in late 2011 to early 2016. Comparison of the non-calibrated VIIRS Earth Data Record (EDR) and calibrated VIIRS EDR shows water-leaving radiance for $nL_w(410)$, $nL_w(443)$, $nL_w(486)$ and $nL_w(551)$ are overestimated by over 8% and $nL_w(671)$ significantly underestimated. We demonstrate that $nL_w(\lambda)$ and other L2 products are reasonably good following initial calibration 3-6 months after launch even though it takes ~ 2 years to derive the stable vicarious calibration gains. High-quality $nL_w(\lambda)$ and other L2 products with minimal biases and deviations can be achieved one year after launch. This study demonstrates the ocean color products from future satellite missions such as the JPSS follow-on missions can reach reasonably good quality in 6 months following the vicarious calibration with MOBY *in-situ* measurements for both research purpose and operational applications as long as the on-orbit VIIRS calibration and characterization are well conducted, and the sensor radiometric stability, degradation are characterized and monitored accurately.

Figure 5

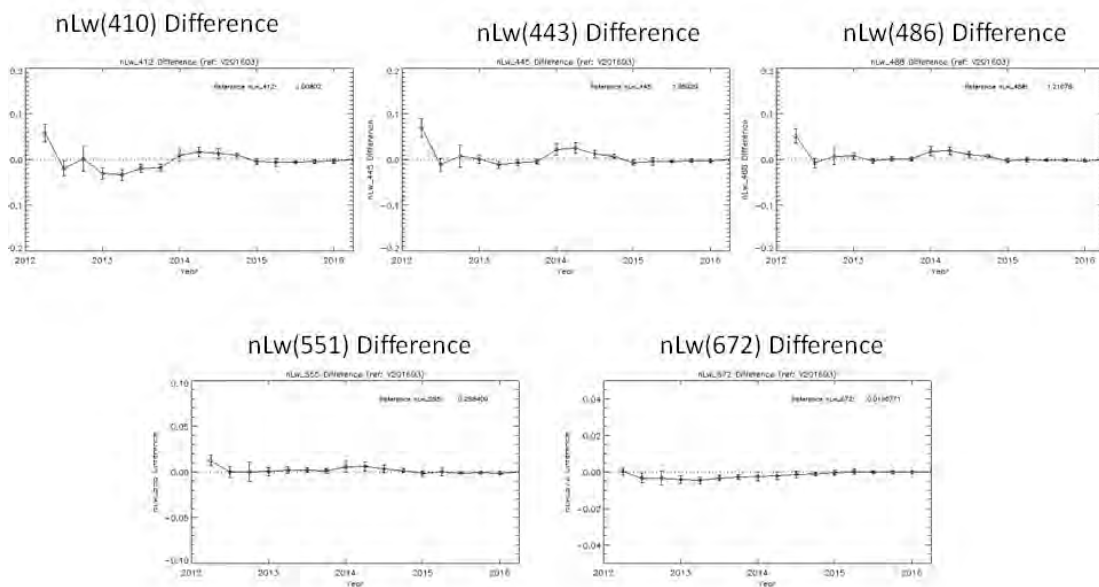

Figure Caption:

Time series of the mean and standard deviation values of water-leaving radiance difference between the VIIRS reference science quality $nL_w^{ref}(\lambda)$ and the $nL_w^{temp}(\lambda)$ produced with the temporal VC gain set of $g^{temp}(\lambda)$ in a time interval of 3 months for (a) $nL_w^{temp}(410) - nL_w^{ref}(410)$, (b) $nL_w^{temp}(443) - nL_w^{ref}(443)$, (c) $nL_w^{temp}(486) - nL_w^{ref}(486)$, (d) $nL_w^{temp}(551) - nL_w^{ref}(551)$, and (e) $nL_w^{temp}(671) - nL_w^{ref}(671)$.

Title: Deriving total suspended matter concentration from the near-infrared-based inherent optical properties over turbid waters: A case study in Lake Taihu

Author(s): Wang, M. and W. Shi

In progress

Abstract: Normalized water-leaving radiance spectra $nL_w(\lambda)$, particle backscattering coefficient $b_{bp}(\lambda)$ in the near-infrared (NIR) wavelengths, and the total suspended matter (TSM) concentration over turbid waters are analytically correlated. To demonstrate the use of $b_{bp}(\lambda)$ in the NIR wavelengths in the coastal and inland waters, we use *in-situ* optics and TSM data to develop two TSM algorithms from measurements of the Visible Infrared Imaging Radiometer Suite (VIIRS) on the Suomi National Polar-orbiting Partnership (SNPP) using backscattering coefficients at the two NIR bands $b_{bp}(745)$ and $b_{bp}(862)$ in Lake Taihu. The correlation coefficients between the modeled TSM concentrations from $b_{bp}(745)$ and $b_{bp}(862)$ and the *in-situ* TSM are 0.93 and 0.92, respectively. These two NIR-based TSM algorithms are used to compute the satellite-derived TSM concentrations to study the seasonal and interannual variability of the TSM concentration in Lake Taihu between 2012 and 2016. Advantages of the NIR-based TSM algorithms are also discussed, and they have the potential to be used for TSM concentrations in the waters with similar NIR $nL_w(\lambda)$ spectra as those in Lake Taihu.

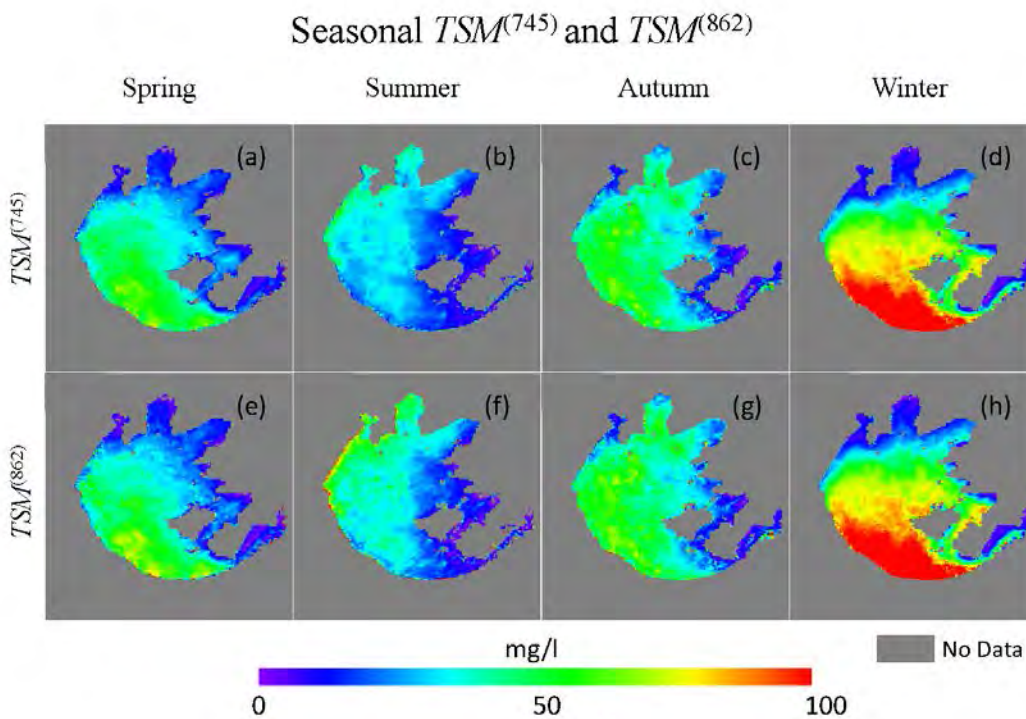

Figure 6

Figure caption: Seasonal climatology $TSM^{(745)}$ images (a–d) and $TSM^{(862)}$ images (e–h) for spring, summer, autumn, and winter, respectively.

PROJECT TITLE: NESDIS Research Scientist and Post Doc Program, Seunghyun Son, Research Scientist II

PRINCIPAL INVESTIGATORS: Steve Miller, Cliff Matsumoto

RESEARCH TEAM: Seunghyun Son

NOAA TECHNICAL CONTACT: Menghua Wang, STAR/SOCD/MEB

NOAA RESEARCH TEAM: Menghua Wang

FISCAL YEAR FUNDING (NEAT Total): \$2,104,544

PROJECT OBJECTIVES:

- 1--Processing and validation/evaluation of the JPSS VIIRS data
- 2--Development of bio-optical and biogeochemical algorithms for the satellite ocean color data use in the various ocean waters (clear open ocean, coastal and inland waters).
- 3--Processing and validation/evaluation of the Korean GOCI data.

PROJECT ACCOMPLISHMENTS:

- 1--The VIIRS data sets from various processing methods (e.g., IDPS-EDR, OC-SDR-EDR, NOAA-MSL12) have been being processed over the various clear ocean and coastal/inland waters (Hawaii region, South Pacific Gyre, US east coast, Yellow & East China seas, Mediterranean Sea, etc.). In situ bio-optical data were compared for validation of the VIIRS data in various regions.
- 2--New developed chlorophyll-a algorithm for VIIRS data was implemented to the VIIRS routine processing. The results have been presented in international meetings and published in a scientific journal.
- 3--Regional algorithms for Sea-Ice mask and turbidity for use of satellite ocean color data in the Great Lakes are updated, and the optical properties in the Great Lakes are characterized. The results were regenerated and will be submitted to a peer-reviewed journal.
- 4--The Korean GOCI data sets have been reprocessed over the Northwestern Pacific area, and evaluated and compared with VIIRS data. The results were presented in an international workshop.

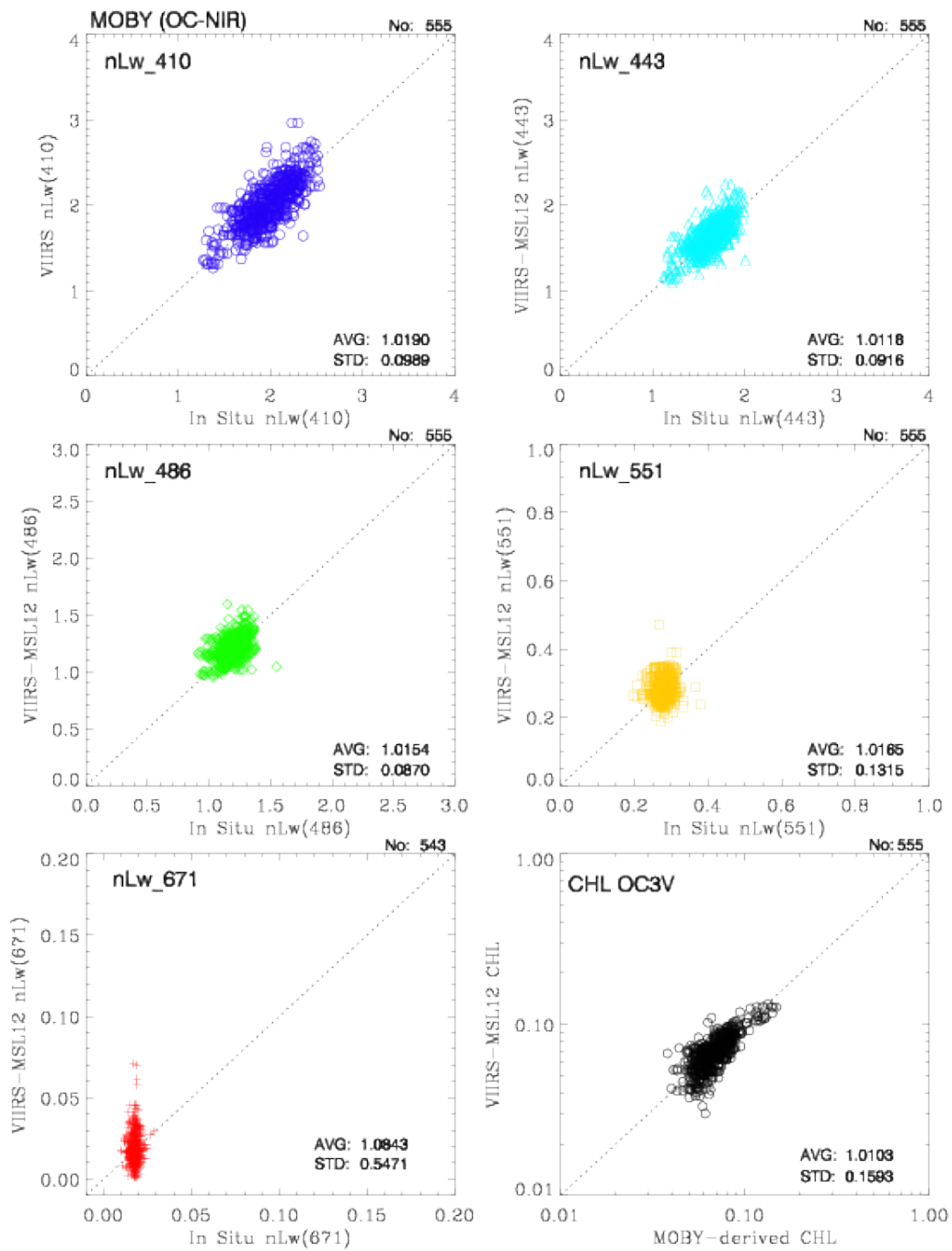

Figure 1. Matchup comparison between MOBY in situ and VIIRS-derived $nL_{dw}(\lambda)$ and Chl-a measurements using the OC-SDR NIR processing.

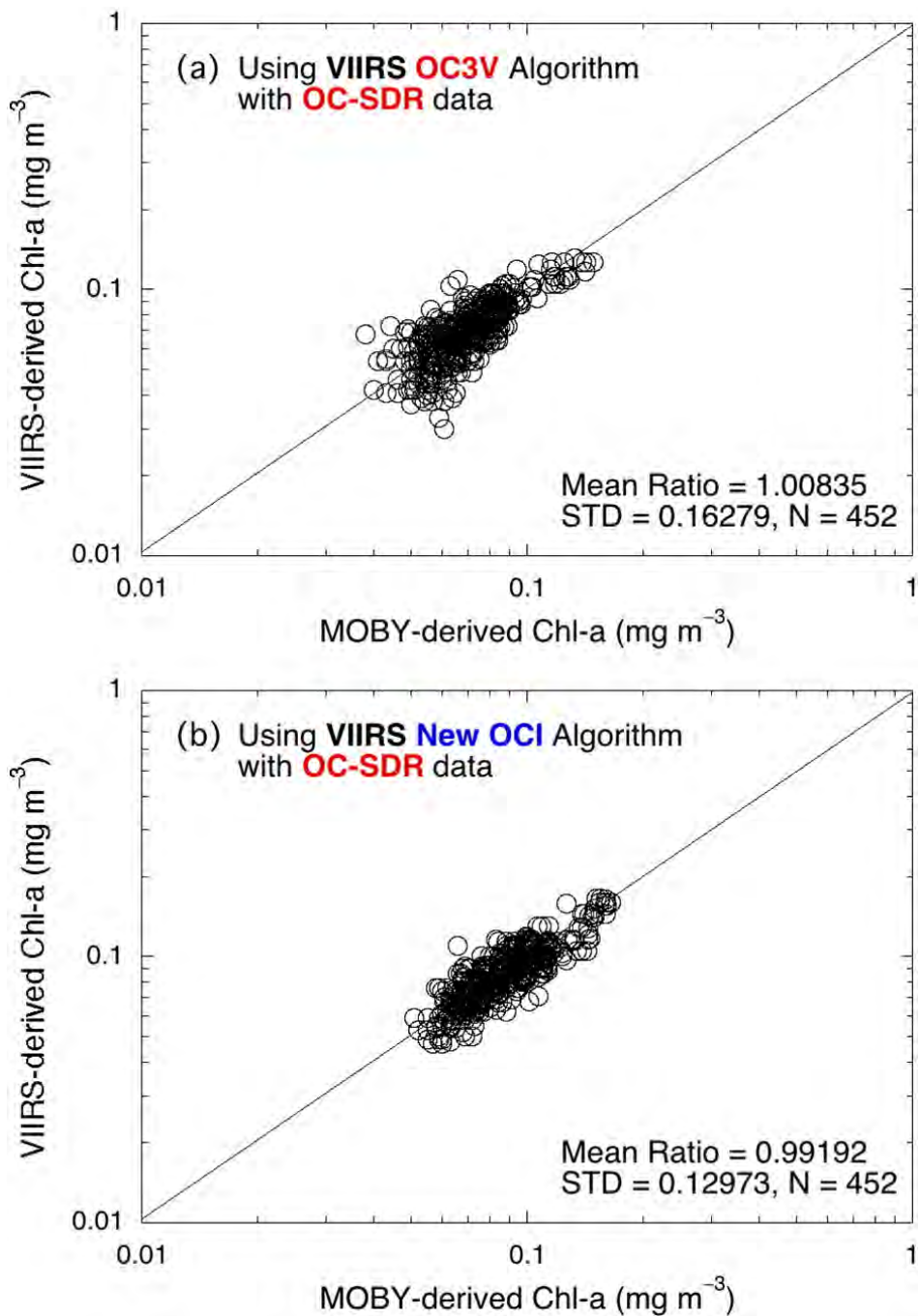

Figure 2. VIIRS-derived Chl-a data compared with those derived from the in situ MOBY optics data using the same Chl-a algorithm of (a) OC3V and (b) the new OCI algorithm.

VIIRS-NSW Climatology (2012–2015) Images

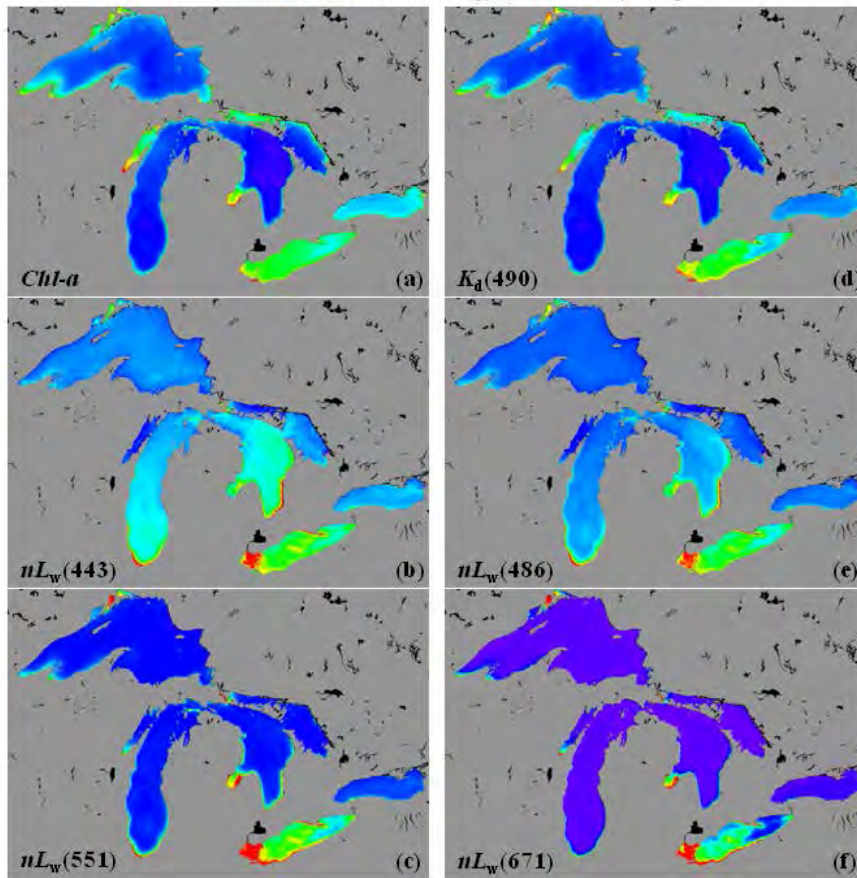

Figure 3. Climatology composite (February 2012 to December 2015) images of the VIIRS-derived (a) *Chl-a*, (b) $K_d(490)$, (d) $nL_w(443)$, (d) $nL_w(486)$, (e) $nL_w(551)$, and (f) $nL_w(671)$ using the NIR-SWIR atmospheric correction algorithm and the new ice detection method in the Great Lakes.



Climatology Monthly $nL_w(443)$ Images (Jan. 2012 - Dec. 2015)

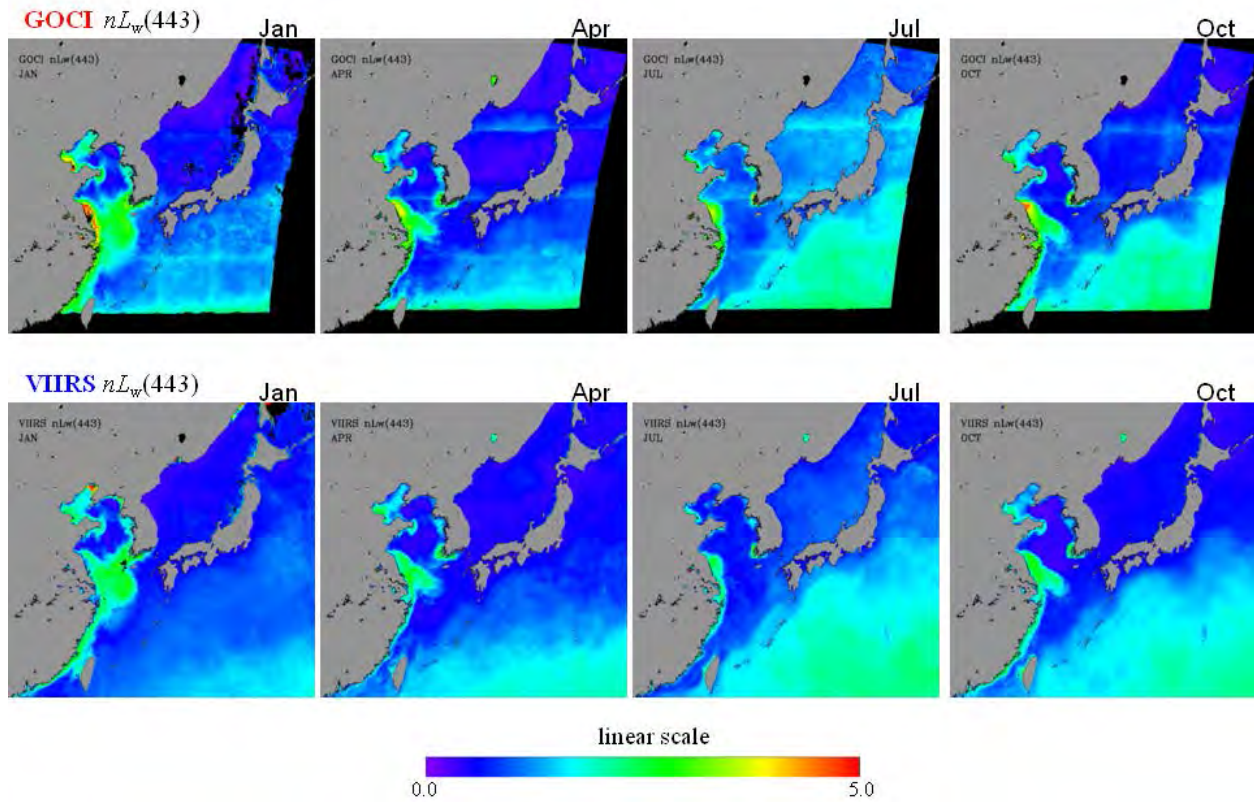

Figure 4. Climatology (January 2012 to December 2015) monthly composite images of GOCI-derived (upper column) and VIIRS-derived (lower column) $nL_w(443)$ for the months of January, April, July, and October in the Northwestern Pacific area (GOCI coverage).

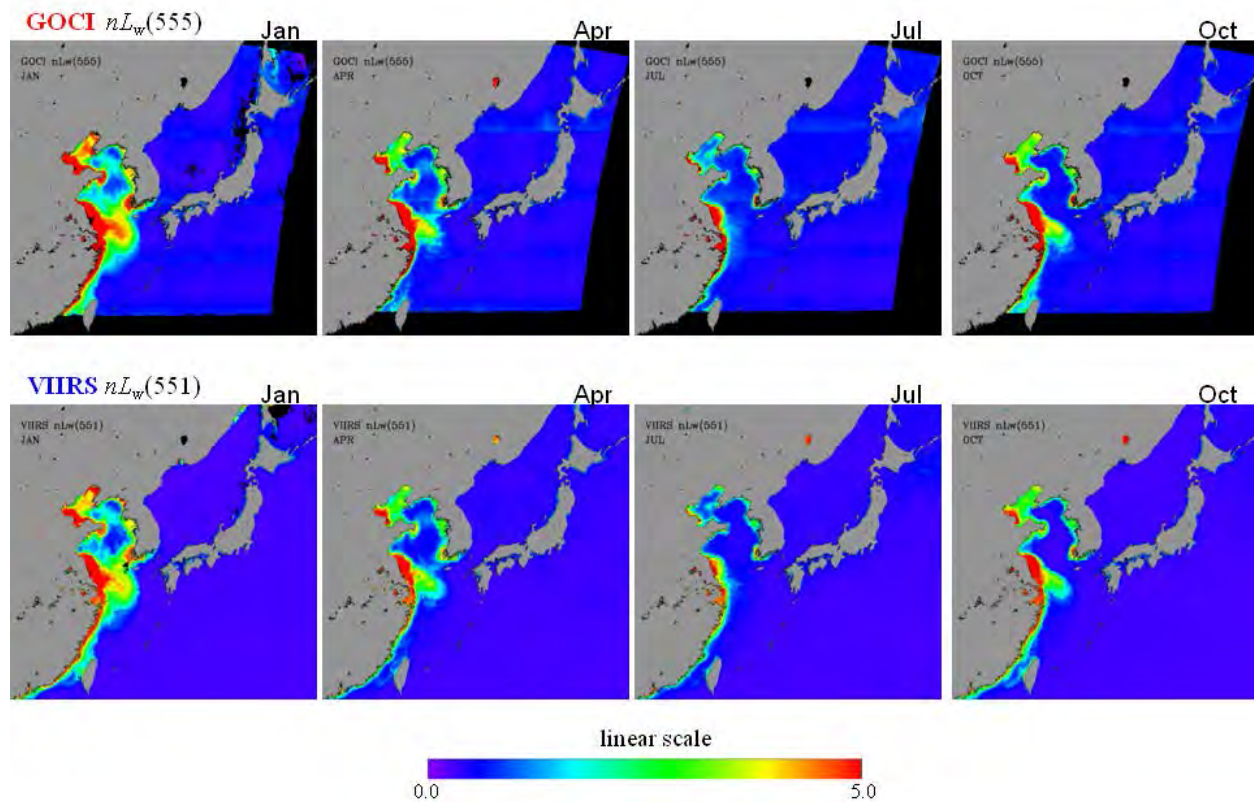

Figure 5. Climatology (January 2012 to December 2015) monthly composite images of GOCI-derived $nL_w(555)$ (upper column) and VIIRS-derived $nL_w(551)$ (lower column) for the months of January, April, July, and October in the Northwestern Pacific area (GOCI coverage).

Publications:

Wang, M. and S. Son, 2016). VIIRS-derived chlorophyll-a using the ocean color index method, Remote Sensing of Environment, 182, 141-149.

Presentations:

Mikelsons, K., S. Son and, M. Wang, Evaluation of Sentinel-3 OLCI data products through comparison with SNPP-VIIRS and MOBY in-situ data (at the ESA Sentinel-3 Validation Team Meeting, ESA ESRIN, Frascati, Italy, February 15-17, 2017).

Son, S. and M. Wang, VIIRS-derived chlorophyll-a using ocean color index method (at the 4th Asian/13th Korean-Japan Workshop on Ocean Color, Burapa University, Thailand, December 13–16, 2016).

Son, S. & M. Wang, Evaluation of VIIRS Ocean Color Products in Open Ocean and Coastal/Inland Waters (at Ocean Optics XXIII Meeting 2016, Victoria, Canada, October 25-31, 2016).

Son, S. & M. Wang, Comparison of GOCI and VIIRS ocean color products in the Western Pacific region (at International GOCI Symposium 2016 – 4th GOCI PI Workshop & 2nd GOCI-II Workshop, Jeju, South Korea, September 27-30, 2016).

Wang, M, J. Lide, X. Liu, S. Son, J. Sun, W. Shi, L. Tan, K. Mikelsons, X. Wang & V. Lance, VIIRS Ocean Color Products: A Progress Update (at the IGARRS 2016 Meeting, Beijing, China, July 10-15, 2016).

Wang, M., K. Mikelsons, L. Jiang, X. Liu, & **S. Son**, Satellite ocean color data monitoring tool (at the 4th Asian/13th Korean-Japan Workshop on Ocean Color, Burapa University, Thailand, December 13-16, 2016).

Wang, M., X. Liu, J. Lide, S. Son, J. Sun, K. Mikelsons, W. Shi, L. Tan, X. Wang & V. Lance. VIIRS mission-long ocean color data reprocessing (at the 4th Asian/13th Korean-Japan Workshop on Ocean Color, Burapa University, Thailand, December 13-16, 2016).

PROJECT TITLE: NESDIS Environmental Applications Team, Liqin Tan, Research Associate

PRINCIPAL INVESTIGATORS: Steve Miller, Cliff Matsumoto

RESEARCH TEAM: Liqin Tan (CIRA/CSU)

NOAA TECHNICAL CONTACT: Menghua Wang (NOAA)

NOAA RESEARCH TEAM: Menghua Wang (NOAA team lead)

FISCAL YEAR FUNDING (NEAT Total): \$2,104,544

PROJECT OBJECTIVES:

--Performing VIIRS instrument characterization and calibration for ocean color (OC) data processing and applications. Evaluating the effect of VIIRS instrument performance on the science data quality and quantify the impact

--Understanding, evaluation, and refining VIIRS ocean color (OC) data processing system

PROJECT ACCOMPLISHMENTS:

--Collaborated with VIIRS SDR team and monitored the development of VIIRS instrument calibration activities, operational IDPS SDR production, and Discrepancy Records (DRs). Participated in VIIRS SDR team weekly teleconference. Attended NASA mandatory training for accessing to JPSS data in eRooms and MIS.

--Routinely downloading the required ANC/AUX data and searching for missing IDPS operational RDR from various data sources for our SNPP and J1VIIRS calibration and characterization analysis and SDR data processing. Continue collecting /archiving IDPS Fast-Track VIIRS SDR GEO/Calibration LUTs, SNPP VIIRS-SDR-F-Predicted-LUTs, SNPP VIIRS-RSBAUTOCAL-HISTORY-AUXs, Predicted SNPP Ephemeris data, J1 VIIRS SDR GEO/Calibration and RSBAutoCal LUTs, the RSR data, and J1/J2 VIIRS pre-Launch polarization sensitivity measurement data etc.

--Compiled and built the new ADL4.2_Mx8.11 code on our Linux system. Traced and studied the VIIRS SDR code changes /updates.

--Enhanced my ADL-based RDR to SDR data reprocessing tool for better efficiency and control. Updated the tool with ADL4.2_Mx8.11. It can be used to run RDR to SDR Cal process in both manual mode and RSBAutoCal mode.

--Communicated with the VIIRS SDR Team and obtained their calibration reprocessing data (input RSB LUTs, and output VIIRS-RSBAUTOCAL-HISTORY-AUX files).

--Modified and enhanced my VIIRS SDR RSBAutoCal process tool and upgraded it with ADL4.2_Mx8.11. Given an initial VIIRS-RSBAUTOCAL-HISTORY-AUX file and the required RSBAutoCal LUT set, the updated RSBAutoCal process tool can be used to automatically reprocess OBC-IP of selected solar-event ("sweet spots") into updated VIIRS-RSBAUTOCAL-HISTORY-AUX (as the input to the VIIRS SDR Cal process) for specified period, to simulate the IDPS VIIRS SDR RSBAutoCal process.

--Wrote scripts to invoke GRAVITE LUT_Converter software package and converted IDPS SNPP VIIRS SDR LUTs (for both ADL4.2_Mx8.10 and ADL4.2_Mx8.11) and the preliminary J-1 VIIRS SDR LUTs binary files into text format for verification and calibration analysis.

--Converted SNPP VIIRS RDR granules into verified RDR HDF5 files and retrieved the earth view dn data for MOBY site of January, 2016.

--Modified my F-LUTs compiling tool to be more convenient to use. Compiled our team's VIIRS RSB calibration F LUTs (OC F LUTs) versions OC04 and OC04 into IDPS/ADL compatible binary format to be used in IDPS/ADL RDR to SDR data processing.

--Performed daily OC Team operational SNPP VIIRS OC EDR products status monitoring (VIIRS Global Ocean Color Composite Images, both Near-Real-Time stream and Science-Quality stream) and data quality check.

--Performed data comparison of SNPP VIIRS OC EDR Level 3 products generated from Ozone inputs.

--Supported the JPSS J1 pre-launch SDR calibration data analysis for OC EDR.

Publications:

Wang, M., L. Jiang, X. Liu, S. Son, J. Sun, W. Shi, L. Tan, K. Mikelsons, X. Wang, and V. Lance, "VIIRS ocean color products: A progress update", *Proc. IGARSS '16*, pp.5848-5851 (2016). doi:10.1109/IGARSS.2016.7730528

PROJECT TITLE: PROJECT TITLE: NESDIS Environmental Applications Team (NEAT) and NEAT Expansion, Sirish Uprety, Research Associate - Suomi NPP VIIRS calibration and validation

PRINCIPAL INVESTIGATORS: Steven Miller, Cliff Matsumoto

RESEARCH TEAM: Sirish Uprety

NOAA TECHNICAL CONTACT: Changyong Cao (5825 University Research Ct., College Park, MD)

NOAA RESEARCH TEAM: Changyong Cao (NOAA/NESDIS/STAR) and Sirish Uprety (CIRA, CSU)

FISCAL YEAR FUNDING (NEAT Total): \$2,104,544

PROJECT OBJECTIVES:

On-orbit calibration and validation of Suomi NPP VIIRS:

- 1--Support the operational calibration of VIIRS DNB by generating and supplying monthly look up tables.
- 2--Develop the capability to generate and analyze the VIIRS DNB monthly calibration parameters using VROP and onboard calibrator data.
- 3--Analyze the impact of Airglow in DNB calibration
- 4--Continuously monitor and evaluate the S-NPP VIIRS radiometric performance using SNO-x.
- 5--Provide the feedbacks on VIIRS performance on regular basis to VIIRS cal/val team and through publications.
- 6--VIIRS SDR team reporting (weekly and quarterly)

PROJECT ACCOMPLISHMENTS:

- 1--Support the operational calibration of VIIRS DNB by generating and supplying monthly look up tables

Day/night band (DNB) onboard the SNPP Visible Infrared Imager Radiometer Suite (VIIRS) is the advancement for nighttime imaging capability. To accommodate the imaging during both day and night, it consists of three gain stages (Low/Medium/High gain stage) with dynamic range spanning over 8 orders of magnitude. The calibration parameters for LGS are determined using solar diffuser. However, for MGS and HGS, the gain values are obtained through cross calibration approach which is performed once a month during new moon near terminator region where gain switches among 3 gain stages. Similarly, the dark offset for all three gain stages are also determined once a month during new moon. Figure 1 left shows the DNB dark ocean data during new moon for HGS. In addition, dark offsets are also determined using onboard calibrator data along with deep space view based on pitch maneuver (performed in February 2012). It is possible that the dark offset and gain ratio can change over time. Thus these parameters are analyzed, monitored and updated every month. There are two VIIRS recommended operating procedures (VROP 702, 705) that are performed once every month. Earth view data collected during these VROP are used to estimate the dark offsets and gain ratio for MGS and HGS. We have started to support the operational DNB calibration by supplying the DNB calibration coefficients, Dark Offset and Gain Ratio on monthly basis.

- 2--Started analyzing the impact of Airglow in DNB calibration

Airglow is a faint light emission phenomenon that occurs at different altitudes in the upper atmosphere. Airglow values vary with time and location mainly due to the changes in atmosphere and solar activity. Majority of airglow emissions happen at an altitude of ~90km. DNB dark offset which is used in radiometric calibration are estimated from observations over Pacific Ocean during new moon. However, the presence of airglow increases the uncertainty in offset calculation by overestimating the dark offset by

an amount equivalent to that of airglow. This causes direct impact in calibrated data such that the radiance values are underestimated in the absolute scale. The impact is prominent at low light radiance. Similarly, airglow contamination also increases uncertainty in DNB straylight correction. This study focuses on analyzing the airglow using DNB measurements. In addition, the impact on operational calibrated radiance product and how the absolute accuracy can be improved especially at low light radiance is under analysis.

3--Improve the monthly DNB calibration for low light radiance

DNB dark offset which is estimated monthly using observations over dark ocean during new moon are contaminated by air glow. This causes the overestimation of offset and hence the calibrated radiance gets lower. There is one instance on Feb. 20, 2012 when the instrument was pitch maneuvered to collect deep space data. The benefit of deep space measurement is that it is not contaminated by airglow Figure 3 shows the timing of pitch data along with digital number (DN) for few frames. Earlier studies have shown that DNB pitch maneuver data can be used to estimate the dark counts (DN0) that is free of airglow contamination. Airglow free deep space data produces dark offset values to be smaller than that estimated using dark ocean. The dark offset obtained from pitch maneuver based deep space data can be used along with onboard calibrator data to estimate the dark offset. This leads to improved calibration with reduction in the negative radiance pixels present in IDPS SDR. In addition, the study will be helpful for analyzing J1 VIIRS DNB calibration after launch.

4--Continuously monitor and evaluate the S-NPP VIIRS radiometric performance using SNO-x.

The VIIRS calibration needs to be independently evaluated validated more frequently to ensure that the data quality is well within the specification. Radiometric performance of VIIRS is continuously monitored through intercomparison with AQUA MODIS. Figure 4 shows the VIIRS bias estimated till the end of 2016 for blue bands (M1-M3). The figure shows that bias trends are not stable over time. However, the bias is mostly within 2%. M1 is biased high whereas M2 and M3 are biased low. Larger jumps in bias exist mainly due to LUT updates. VIIRS data are currently under reprocessing phase. Once reprocessed, the changes in bias due to calibration updates and anomalies should disappear and result in more stable and accurate bias time series.

5--VIIRS SDR team reporting

Prepared VIIRS weekly and quarterly reports to provide continuous update on VIIRS calibration and validation activities.

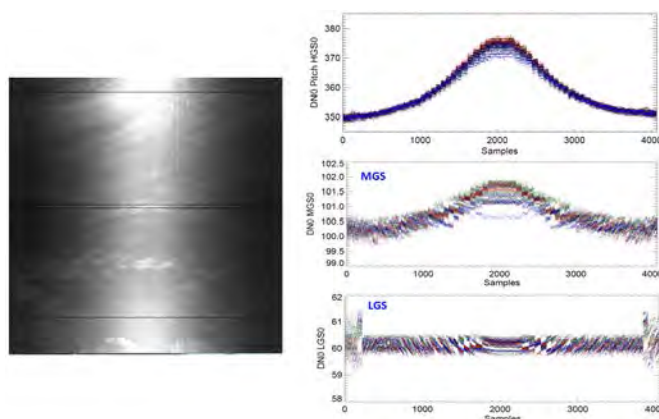

Figure 1. Left: Dark ocean observation from VROP 705 collection and Right: dark offsets estimated for 3 gain stages using dark ocean view.

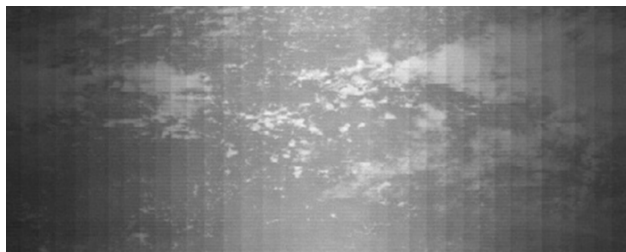

Figure 2. Nighttime DNB raw image over Pacific Ocean during new moon. Airglow illuminated cloud features are clearly seen.

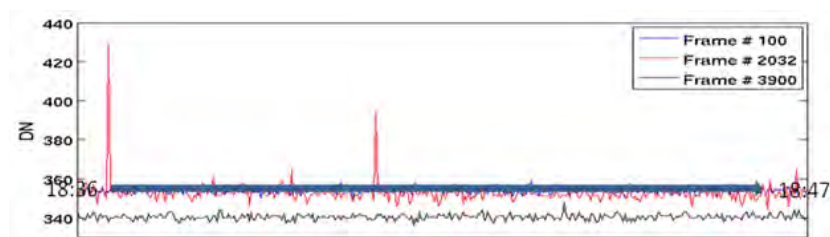

Figure 3. Pitch maneuver based deep space view data for 3 samples as a function of time.

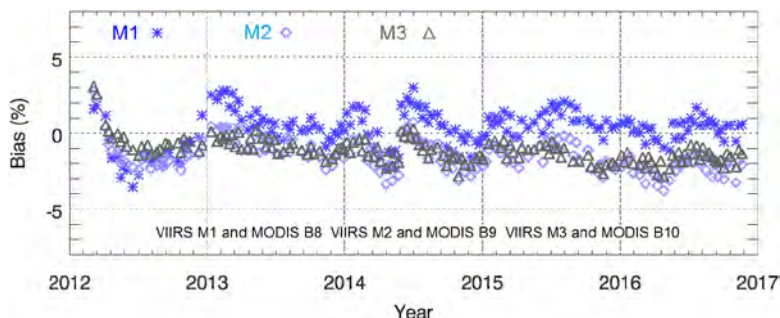

Figure 4. VIIRS bias estimated over desert for M1-3 using extended SNOs

Publications:

Qiu, S., Shao, X., Cao, C., Uprety, S. (2016). Feasibility demonstration for calibrating Suomi-NPP VIIRS Day/Night Band using Dome C and Greenland under moon light. *Journal of Applied Remote Sensing* 10(1) 016024 doi: 10.1117/1.JRS.10.016024.

Uprety, S., Cao, C., & Blonski, S. (2016). Retrospective analysis of Suomi NPP VIIRS radiometric bias for reflective solar bands due to operational calibration changes. *International Journal of Remote Sensing* *International Journal of Remote Sensing* Vol. 37, Iss. 22.

Uprety, S., & Cao, C. (2016). Radiometric comparison of Greenhouse Gases Observing Satellite (GOSAT) TANSO-FTS and Suomi NPP VIIRS 1.6 μ m CO₂ absorption band. *Journal of Atmospheric and Oceanic Technology* doi: <http://dx.doi.org/10.1175/JTECH-D-15-0157.1>.

Uprety, S., Blonski, S., & Cao, C. (2016). On-orbit radiometric performance characterization of S-NPP VIIRS reflective solar bands, Proc. SPIE 9881, doi:10.1117/12.2223788.

PROJECT TITLE: NESDIS Environmental Applications Team (NEAT), Xiao-Long Wang, Research Associate - Software Development for Satellite Data Analysis and Processing

PRINCIPAL INVESTIGATORS: Steve Miller, Cliff Matsumoto

RESEARCH TEAM: Xiao-Long Wang, Lide Jiang, Xiaoming Liu, Wei Shi, Liqin Tan, SeungHyun Son, and Mike Chu

NOAA TECHNICAL CONTACT: Menghua Wang

NOAA RESEARCH TEAM: NOAA SOCD

FISCAL YEAR FUNDING (NEAT Total): \$2,104,544

PROJECT OBJECTIVE:

Develop Ocean Color Data Application & Processing System (OCDAPS) to support VIIRS, GOCI, OLCI, and LANDSAT Ocean color products image visualization, data manipulation and processing.

PROJECT ACCOMPLISHMENTS:

Actively made progresses to support various satellite sensor image visualization (VIIRS, GOCI, OLCI and LANDSAT etc.) with capability for data analysis and processing.

1--Constantly improved various satellite image data visualization, analysis and processing. Supported VIIRS, GOCI, OLCI, MODIS and LANDSAT Ocean Color products in image display, image data manipulation, multiple band image difference computation, data quality flags view, geo-registration, image mapping and re-projection, graphic IO utility, true-color image generation and netCDF input/output,

2--Provided full support for satellite data format transaction from HDF4/HDF5 to netCDF4 in OCDAPS data processing. Support various options in data output (data with navigation info, data only or navigation info only).

3--Created more helping functions to help team users in image analysis and comparisons. Such as target image in global position, various displayed image smooth/filtering, enhance image colors with missing value setup, etc.

4--Updated and improved OCDAPS system documentation and user guide in HTML files. Provide expandable web-links for user help.

5--Improved graphic plotting functions for more control options in scattering and histogram plots.

6--Performed supported for VIIRS/MODIS multiple granule image data aggregation and mapping (with bow-tie removal) for large scale image analysis.

7--Provided sample command scripts to support team member's routine analysis in global or regional ocean color monitoring with batch automatically generated multiple Ocean Color satellite imagery.

8--Continuously building comprehensive system GUI mode / command mode support to perform current and future new satellite data computations and image data analysis and processing for group user's routine batch jobs and command scripts.

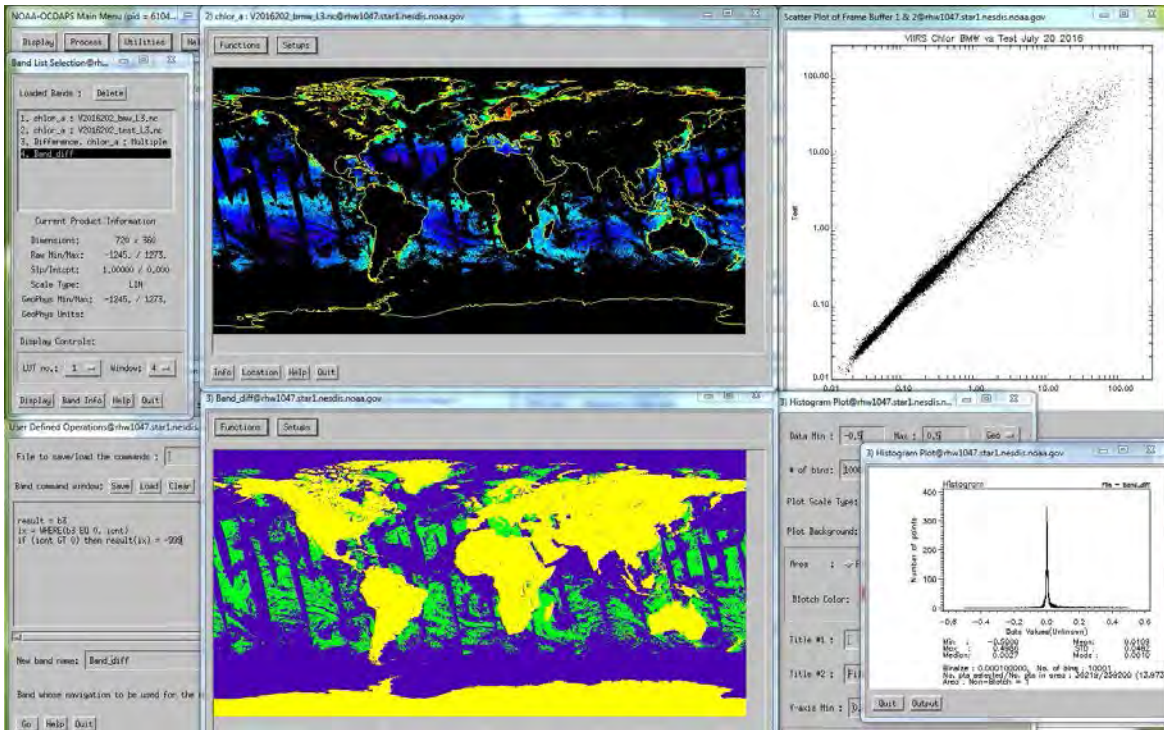

Figure 1. OCDAPS image analysis on VIIRS global L3 Chlorophyll concentration 2 band comparisons from two different algorithms (BMW vs TEST) with scattering plot and histogram plot.

PROJECT TITLE: NESDIS Environmental Applications Team, Xin Xi, Post Doc - Development of Atmospheric Aerosol Correction for Infrared SST Retrieval

PRINCIPAL INVESTIGATORS: Steve Miller, Cliff Matsumoto

RESEARCH TEAM: Xin Xi

NOAA TECHNICAL CONTACT: Alexander Ignatov

NOAA RESEARCH TEAM: Alexander Ignatov

FISCAL YEAR FUNDING (NEAT Total): \$2,104,544

PROJECT OBJECTIVE:

Develop an atmospheric correction algorithm for correcting aerosol-induced (initial focus is on dust) biases in infrared sea surface temperature (SST) retrieval from new-generation polar-orbiting (VIIRS, MODIS) and geostationary satellites (ABI, AHI).

PROJECT ACCOMPLISHMENTS:

During the first year of the project, the focus was on literature research, Mie simulations of regional dust aerosol optical properties using newly published data, and radiative transfer simulations of dust impacts on brightness temperatures (BT) in VIIRS infrared bands.

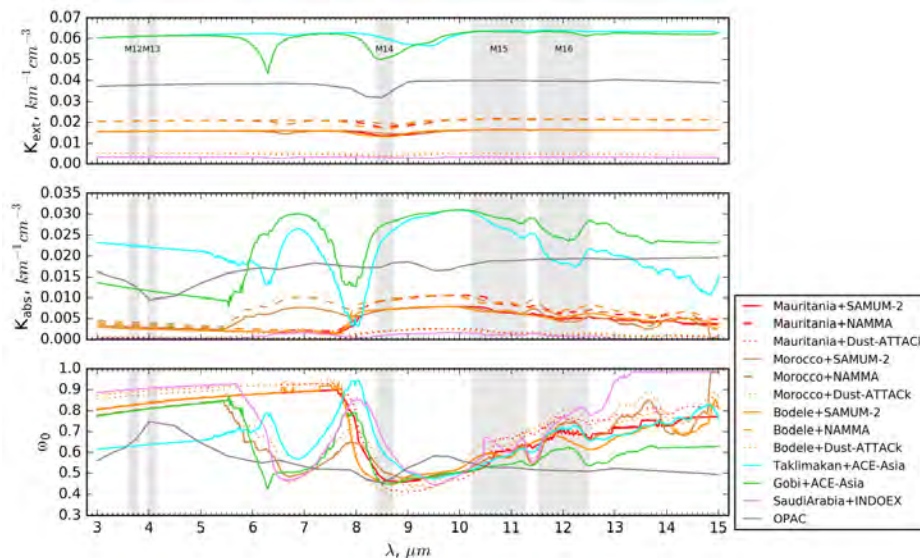

Figure 1. Dust extinction coefficient (K_{ext}), absorption coefficient (K_{abs}), and single scattering albedo ($\omega_0 = K_{scat}/K_{ext}$) for aerosol particles with different refractive indices and size distributions.

Quantifying the effect of dust on multi-channel BTs requires an accurate characterization of the spectral absorption properties of dust particles, which depends on their complex refractive index and size distribution. Past studies employed the OPAC (Optical Properties of Aerosols and Clouds) library, to represent global generic dust characteristics. This study uses newly published data on region-specific dust refractive indices by Di Biagio et al. [2016] (DB16), and in situ measurements of particle number size distribution of dust outflow over oceans, to compute the spectral dust scattering and absorption

coefficients and scattering phase function. Figure 1 shows that there are indeed large differences between the dust properties in DB16 and OPAC – in particular, the spectral absorption at 11 and 12 μm . There are also some regional differences in the spectral behavior of dust absorption.

For radiative transfer simulations, 780 Modern Era Retrospective Analysis for Research and Applications Version 2 (MERRA2) cloud-free atmospheric profiles (pressure, temperature and water vapor mixing ratio) were selected, along with corresponding 2m temperature and surface skin temperatures, representative of Atlantic, Arabian Sea and West Pacific oceans downwind of dust sources.

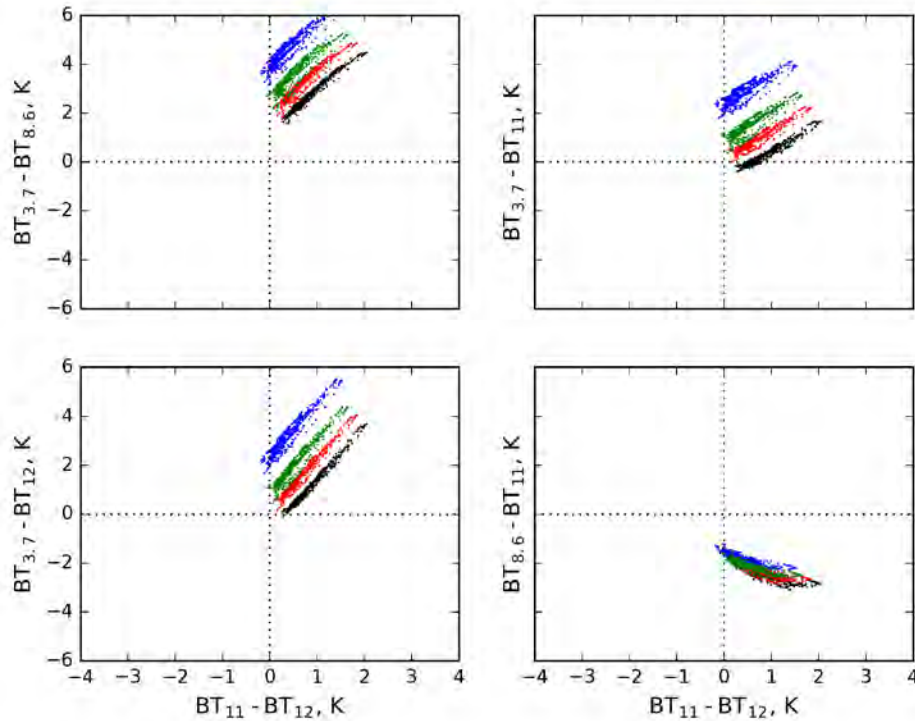

Figure 2. Simulations of VIIRS clear-sky BT differences (BTD) under dust-free (black) and dust-affected (red: AOD=0.2 at 4 km; blue: AOD=0.2 at 8 km; green: AOD=0.4 at 4 km) conditions. The ‘Mauritania + SAMUM-2’ dust case from DB16 is used.

Figure 2 shows the BT differences (BTDs) in four VIIRS bands under clear-sky and dust-affected conditions. Due to stronger water vapor absorption at 8.6 and 12 μm compared to 11 μm , the aerosol-free BTD8.6-11 is negative and the BTD11-12 is positive. Due to even smaller water vapor absorption at 3.7 μm , the BTD3.7-8.6 is also positive (whereas the BTD3.7-11 and BTD3.7-12 may invert their signs, depending on the atmospheric profile). In presence of dust, the BTD8.6-11 becomes less negative, while the BTD11-12 becomes less positive (and in some cases may turn negative). The tri-spectral BTDs at the longwave 8.6, 11, and 12 μm may not be sufficient to discriminate the dust effect on BTs, from the water vapor effect. The 3.7 μm band is more sensitive to dust than the longwave channels, making it a potentially important for dust detection.

To further quantify the BT responses of individual channels to dust, Figure 3 shows the BT biases caused by a dust layer of AOD=0.5 as a function of the base height of dust layer. When the dust layer is situated under 6 km, the reduction in BT is approximately linear with the height. The 3.9 and 4.0 μm channels are less sensitive to aerosol height, because at these channels the aerosol effect on BT is dominated by light scattering, rather than absorption which heavily depends on the temperature of dust layer.

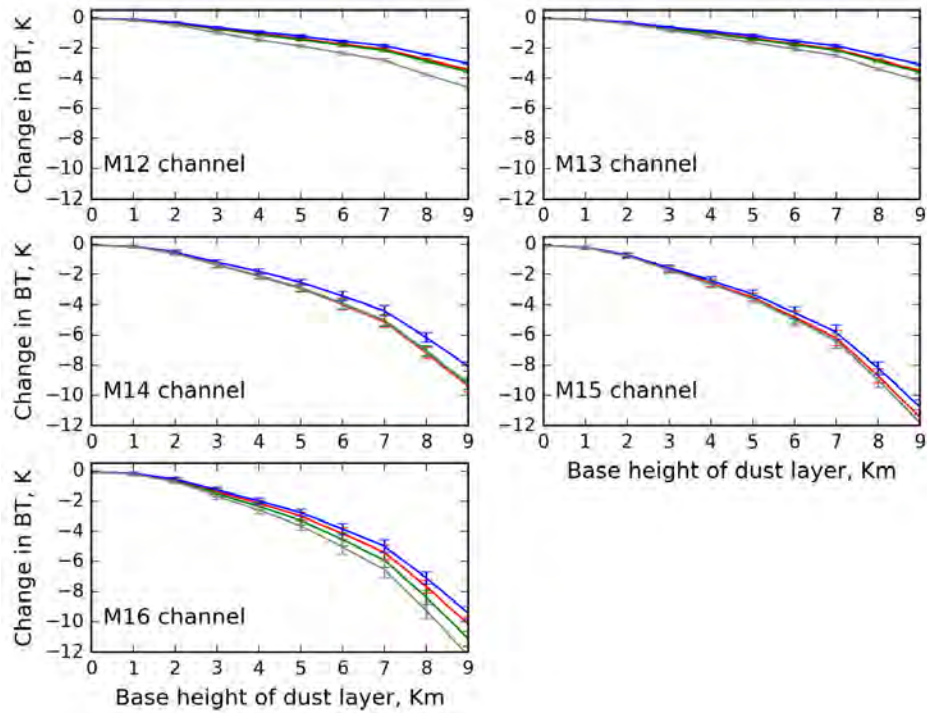

Figure 3. Mean and standard deviation of the changes in BT at five VIIRS channels as a function of the base height of dust layer, for AOD=0.5 at 10 μm and 0° satellite zenith angle. Four dust cases are used: Mauritania_weinzierl (red), Gobi_clarke (green), SaudiArabia_bates (blue), and Opac (gray).

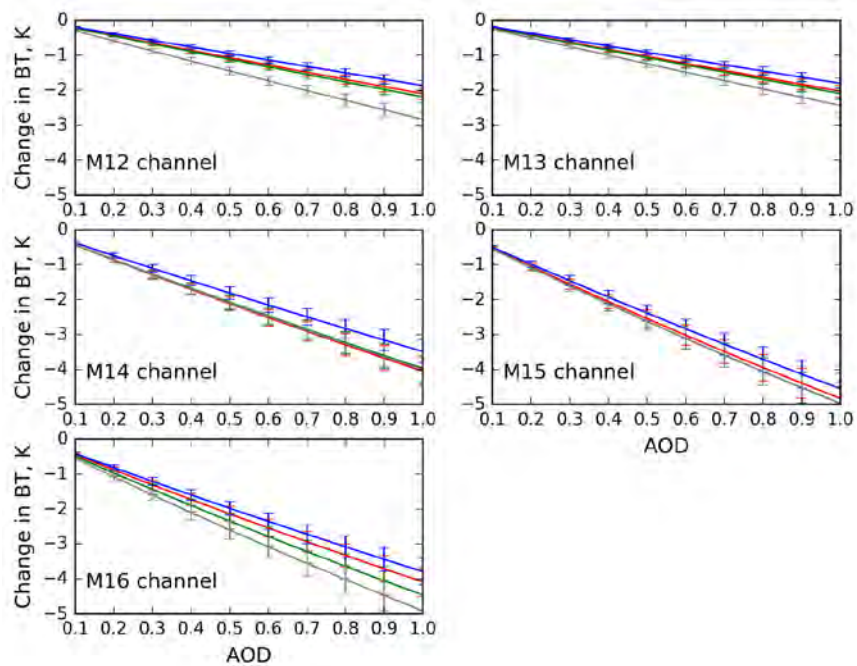

Figure 4. Mean and standard deviation of the changes in BT at five VIIRS channels as a function of dust AOD, for a 1-km dust layer situated at 4–5 km and 0° satellite zenith angle. Four dust cases are used: Mauritania_weinzierl (red), Gobi_clarke (green), SaudiArabia_bates (blue), and Opac (gray).

The relative differences in BT changes between the DB16 and OPAC dust cases appears to be mainly linked to the single scattering albedo in the corresponding VIIRS channels. Overall, the BTs are least sensitive to aerosol for the DB16 “SaudiArabia+INDOEX” case, and more sensitive for OPAC aerosols.

Figure 4 shows the BT biases as a function of AOD for a dust layer located between 4 and 5 km. The BT reduction is highly linear with respect to AOD. The slope varies significantly among different channels.

Further work will include comparing these theoretical simulations with the real BTs observed by polar and geostationary satellite sensors, and testing out various formulations of the aerosol correction algorithms.

Publications:

Xi, X., and A. Ignatov. Developing an atmospheric correction of tropospheric dust in the infrared SST retrieval for the NOAA ACSPO system. 18th Int’l GHRSSST Science Team Meeting, 5-9 June 2017, Qingdao, China.

PROJECT TITLE: NESDIS Environmental Applications Team, Xinjia Zhou, Research Associate - VIIRS and AVHRR GAC SST Reanalysis and Validation

PRINCIPAL INVESTIGATORS: Steve Miller, Cliff Matsumoto

RESEARCH TEAM: Xinjia Zhou, Yanni Ding

NOAA TECHNICAL CONTACT: Alexander Ignatov

NOAA RESEARCH TEAM: Alexander Ignatov, Boris Petrenko, Yury Kihai, Kai He, Maxim Kramar, Feng Xu

FISCAL YEAR FUNDING (NEAT Total): \$2,104,544

PROJECT OBJECTIVES:

1--In conjunction with A. Ignatov and B. Petrenko, perform Advanced Clear-Sky Processor for Oceans (ACSPO) Reanalysis v2 (RAN2) of AVHRR GAC Sea Surface Temperature (SST) and Reanalysis v1 (RAN1) of VIIRS Sea Surface Temperature (SST);

2--In conjunction with Kai He, Yanni Ding, Maxim Kramar and other team member, expand the functionality of the NOAA SST Quality (SQUAM2; www.star.nesdis.noaa.gov/sod/sst/squam2/), to include new NOAA Level 3U product and new geostationary satellites, Himawari-8 and GOES-R (now GOES-16);

3--In conjunction with Feng Xu and Kai He, improve the NOAA in-situ SST Quality Monitor v2.10 (iQuam2; www.star.nesdis.noaa.gov/sod/sst/iquam/v2/) and support routine operations.

PROJECT ACCOMPLISHMENTS:

1--In conjunction with SST team, continued working on the Advanced Clear-Sky Processor for Oceans (ACSPO) Reanalysis of VIIRS Sea Surface Temperature (SST), displaying results online, and presenting at national and international meetings;

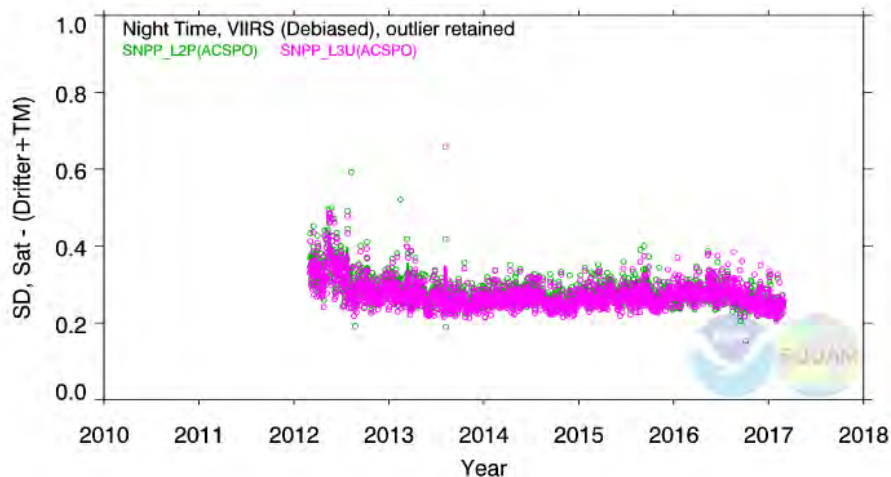

Figure 1. Night time $SD(T_{Sat} - T_{in\ situ})$: ACSP0 SST derived using static regression coefficients, all data from Mar 2012 – pr. Each data point represents a daily statistic based on matchups with *in situ* SSTs. Green symbol represents for NOAA Level 2P product, pink symbol represent for new NOAA Level 3U product (see No. 5 below).

2--In conjunction with SST team, continued working on the ACSP0 Reanalysis of AVHRR SST, displaying results online, presenting at national and international meetings;

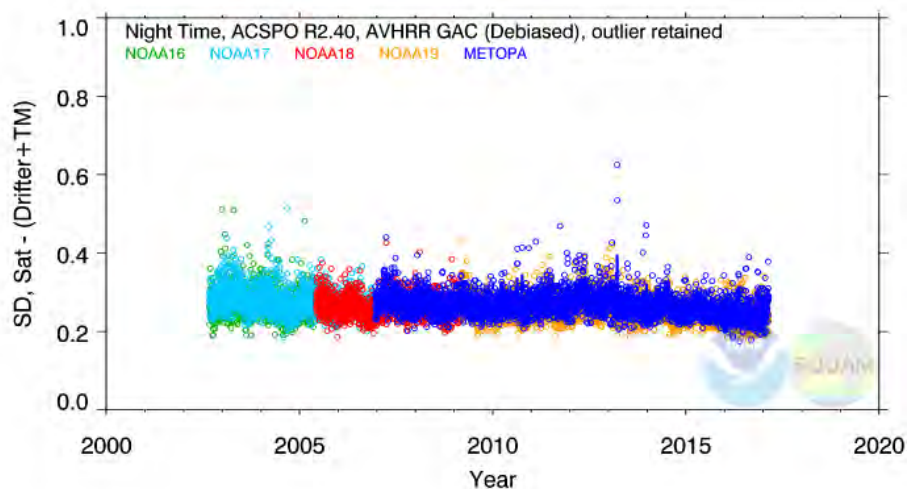

Figure 2. Night time $SD(T_{Sat} - T_{in\ situ})$: ACSP0 SST derived using variable regression coefficients, all data from Aug 2002 – pr. Each data point represents a daily statistic based on matchups with *in situ* SSTs.

3--In conjunction with Kai He and other team members, worked on expanding functionality of the NOAA SST Quality (SQUAM2; www.star.nesdis.noaa.gov/sod/sst/squam2/), towards version2 (SQUAM2)

4--In conjunction with Maxim Kramar, Kai He and other team members, worked on including monitoring SST from new geostationary satellites, Himawari-8 and GOES-R (now GOES-16), in SQUAM2;

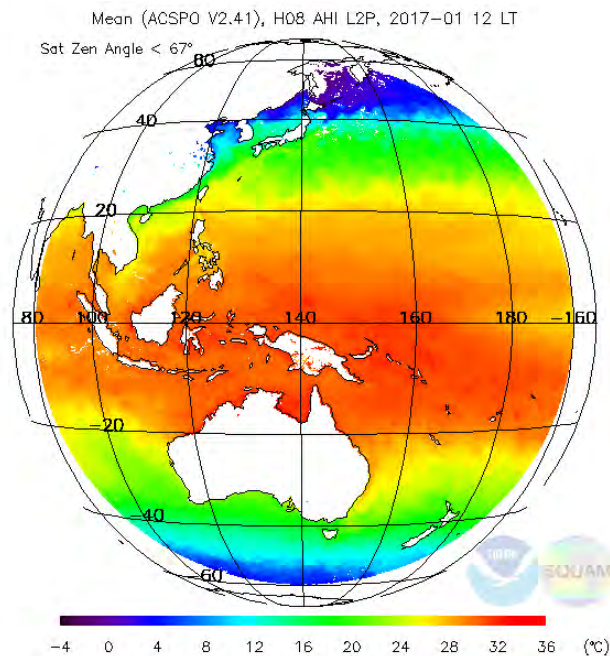

Figure 3. Monthly mean ACSPO SST derived from HIMAWARI-8 AHI, in Jan 2017 noon time.

5--In conjunction with Yanni Ding, and other team members worked on testing and including in SQUAM2 monitoring new NOAA Level 3U product from SNPP VIIRS;

6—In conjunction with Feng Xu and Kai He, worked on improvements to the NOAA in-situ SST Quality Monitor v2.10 (iQuam2; www.star.nesdis.noaa.gov/sod/sst/iquam/v2).

Publications:

Ignatov, A., I. Gladkova, Y. Ding, F. Shahriar, Y. Kihai, X. Zhou, JPSS VIIRS Level 3 Uncollated SST Product at NOAA, *J. Appl. Remote Sens.*, in review.

Ignatov, A., F. Xu, and X. Zhou (2016). Redesign in situ SST Quality Monitor: *iQuam* version 2. *JTech*, in prep.

Presentations:

Ignatov, A., B. Petrenko, Y. Kihai, M. Kramar, I. Gladkova, P. Dash, X. Liang, X. Zhou, Y. Ding, K. He, J. Stroup, J. Sapper, Current Status and Future Enhancements to ACSPO SST Products at NOAA, 17-21 April 2016, Baltimore, MD. (Oral.)

Ignatov, A., B. Petrenko, Y. Kihai, M. Kramar, I. Gladkova, P. Dash, X. Liang, X. Zhou, Y. Ding, K. He, J. Stroup, J. Sapper, Enterprise SST Products at NOAA, 2016 Living Planet Symposium, 9-14 May 2016, Prague, Czech Republic. (Oral.)

Ignatov, A., Y. Kihai, B. Petrenko, I. Gladkova, M. Kramar, X. Zhou, Y. Ding, J. Sapper, NOAA ACSPO SST Products, GHRSSST XVII, 6-10 June 2016, Washington, DC. (Oral.)

Ignatov, A. and X. Zhou, Three AVHRR CDRs from 2002-2015: Initial Comparisons with *iQuam* at Night, GHRSSST XVII, 6-10 June 2016, Washington, DC. (Oral.)

Ignatov, A., X. Zhou, P. Dash, K. He, M. Kramar, F. Xu, NOAA iQuam and SQUAM Monitoring systems, GHRSSST XVII, 6-10 June 2016, Washington, DC. (Oral.)

Ignatov, A., X. Zhou, B. Petrenko, Y. Kihai, P. Dash, X. Liang, J. Stroup, AVHRR GAC SST Reanalysis version 1 (RAN1), GHRSSST XVII, 6-10 June 2016, Washington, DC. (Poster.)

Ignatov, A., B. Petrenko, X. Zhou, P. Dash, X. Liang, K. He, J. Stroup, F. Xu, Y. Kihai, Satellite and in situ SST reprocessing and harmonization at NOAA, MARCDAT-IV Workshop, 18-22 July 2016, Southampton UK. (Oral.)

Ignatov, A., B. Petrenko, I. Gladkova, Y. Kihai, Y. Ding, X. Zhou, K. He, P. Dash, X. Liang, JPSS SST STAR Progress Report, 2016 JPSS Annual Mtg., 8-12 Aug 2016, College Park, MD. (Oral.)

Ignatov, A., Y. Kihai, X. Zhou, S-NPP VIIRS SST Feedback to VIIRS SDR, STAR JPSS Leads Meeting, 27 Feb 2017, College Park, MD

Zhou, X., A. Ignatov, F. Xu, Recent improvements to the NOAA iQuam2 system, 17-21 April 2016, Baltimore, MD. (Oral.)

PROJECT TITLE: NESDIS Environmental Applications Team, Tong Zhu, Research Scientist - Community Radiative Transfer Model Development and Maintenance

PRINCIPAL INVESTIGATORS: Steve Miller, Cliff Matsumoto

RESEARCH TEAM: Tong Zhu

NOAA TECHNICAL CONTACT: Thomas Auligne (NOAA/JCDSA)

NOAA RESEARCH TEAM: Benjamin T. Johnson (UCAR), Quanhua Liu (NOAA/NESDIS/STAR), Yong Chen (UMD), Jean-Luc Moncet and Yingtao Ma (AER), Kevin Garrett (Riverside), Zaizhong Ma (IMSG), Zhenglong Li (CIMISS).

FISCAL YEAR FUNDING (NEAT Total): \$2,104,544

PROJECT OBJECTIVES:

- 1--CRTM transmittance coefficient generation package
- 2--Demonstrate the OSS unapodized radiance simulation capability
- 3--CRTM Scientific upgrade and maintenance
- 4--Independent assessment of CLBLM
- 5--CRTM user support

PROJECT ACCOMPLISHMENTS:

1--We have worked on the generate CRTM coefficients for new and updated satellite sensors. Six new CRTM coefficients were generated during the past year, including the CubeSat MicroMAS2 and CIRAS for the Joint OSSE team; the INSAT3DR IMGR and SNDR for India; and the JPSS1 ATMS and VIIRS. For the new CIRAS coefficient, we are working on adding the Nonlocal thermodynamic equilibrium (NLTE) correction for the daytime simulations near 4.3 μm spectral regions. We also reinvestigated the

issue in the ATMS_NPP coefficients generated from NASA released real Spectral Response Function (SRF). It was found that the biases of the observation-minus-forecast simulations for the channel-6 and 9 brightness temperatures can be reduced by using the reversed real SRF data.

2--During the past year, we have worked on the implementation of the Optimal Spectral Sampling (OSS) model into CRTM v2.2.0. The CRTM-OSS alpha release was generated, and sent to AER and STAR users for the impact studies and further improvement. The Optimal Spectral Sampling (OSS) method is a fast and accurate method for calculating molecular absorption in radiative transfer calculations. The OSS is conceptually a simple approach for extending the k-distribution or exponential sum fitting of transmittance techniques to vertically inhomogeneous atmospheres. After implementing OSS into CRTM repository, we performed benchmark test, K-Matrix (KM), Tangent Linear (TL) and Forward Finite Difference (FFD) Jacobians consistency tests. The results showed that there was some difference between KM and FFD water vapor Jacobians, and AER is working on the improvement of it. The Cross-track Infrared Sounder (CrIS) observations were used to compare and demonstrate the CRTM-OSS unapodized radiance simulation capability, which is one of the important benefits of the OSS method and should enhance spectral sensitivities to the retrievals of trace gases.

3--We have been working on the CRTM next release (Rel-2.3.0) for about half year. First, we have reviewed all previous defined Rel-2.3.0 related tickets. Some new implementations were also added to this release, such as CrIS full spectral resolution (FSR) coefficients, AIRS NLTE coefficients, MHS antenna correction coefficients, and bug fixes for 3.9 μm simulation, and for Microwave sensor TL and AD module interfaces. Most of Rel-2.3.0 related developments have been integrated into CRTM trunk. We are working on merging CRTM trunk with the Cloud Fraction branch, which is an important scientific implementation for this release. After integrating all the developments into CRTM trunk, we will be able to generate the new CRTM release. We plan to finish this task within two months.

4--The Community Line-by-Line Model (CLBLM) will serve as the new LBLRTM, and will be used for training CRTM coefficients. We have performed the independent assessment of the CLBLM, which is still under development by AER. For each version delivered to JCSDA, we performed quick assessment and provided feedback to AER working group. We have also coordinated the activities for the CLBLM implementation. We will keep working on the assessment, which includes the tests of atmospheric path calculation, line-by-line convolution, along-view-path radiance and transmittance calculations, scanning and filtering modules. The results will be compared with those obtained from LBLRTM. The computational speed will be examined.

5-- We have worked for CRTM user support, responding user's questions and requests. Following are some examples of our responses. We have helped AER OSS team in setup CRTM-OSS package for the GSI/GFS impact study. We updated SSMIS F16 coefficients for both CRTM v2.0.5 and v2.2.+ versions, in supporting NRL's data assimilation in FNMOC OPS system. We helped Dr. Sarah Lu's aerosol modeling group at ASRC/Albany-SUNY on testing aerosol jacobian calculation with CRTM Rel.2.2.3. We helped Dr. Jun Li's group at CIMSS in CRTM radiance data simulation for OSSE. After users reported the compile failure for CRTM Rel-2.2.3 using gfortran, we found out that it is because the "ERRMSG=argument" is not supported in the [DE]ALLOCATE statements for gfortran old version, and then provided users with the solutions for this issue.

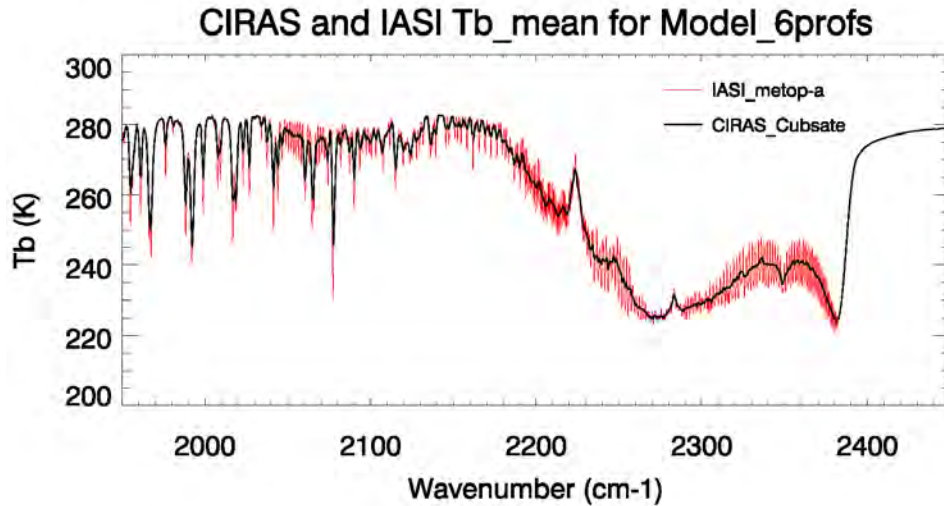

Figure 1. Comparison of the brightness temperature simulations from the new generated CIRAS_CubSat sensor (625 IR bands, 1950 cm^{-1} to 2450 cm^{-1} ; 4.082 μm to 5.128 μm) with IASI Metop-a sensor.

Publications:

Boukabara, S., T. Zhu, H. Tolman, S. Lord, S. Goodman, et. al. (2016) S4: An O2R/R2O Infrastructure for Optimizing Satellite Data Utilization in NOAA Numerical Modeling Systems: A Significant Step Towards Bridging the Gap between Research and Operations. *Bull. Amer. Meteor. Soc.*, 97, 2359–2378.

Ma, Z., E. Maddy, B. Zhang, T. Zhu, and S. Boukabara, (2017): Impact Assessment of Himawari-8 AHI Data Assimilation in NCEP GDAS/GFS with GSI. *J. Atmos. Oceanic Technol (Accepted)*.

Zhu, T., S. Boukabara, and K. Garrett, (2017) Comparing Impacts of Satellite Data Assimilation and Lateral Boundary Conditions on Regional Model Forecasting: Case Study of Hurricane Sandy. *Weather and Forecasting (Early online release)*.

PROJECT TITLE: POES-GOES Blended Hydrometeorological Products

PRINCIPAL INVESTIGATOR: Andrew Jones

RESEARCH TEAM: Stan Kidder, John Forsythe

NOAA TECHNICAL CONTACT: Limin Zhao (NESDIS/OSPO/SPSD/SPB)

NOAA RESEARCH TEAM: Limin Zhao (NESDIS/OSPO/SPSD/SPB), John Paquette (NESDIS/OSPO/SPSD), Ralph Ferraro (NESDIS/STAR/CRPD/SCSB), and others

FISCAL YEAR FUNDING: \$30,000

PROJECT OBJECTIVE:

Develop Enhanced Blended TPW (BTPW), TPW anomaly and Rain Rate (BRR) products with Global Precipitation Mission (GPM) Microwave Imager (GMI) data.

PROJECT ACCOMPLISHMENTS:

This project provides science support to the NOAA operational BTPW and BRR products.

Last year:

- 1--Set up a real-time GPM/GMI/GPROF data feed from NESDIS
- 2--Wrote the code to ingest the real-time GPM data (in HDF5 format) into DPEAS.
- 3--Learned that the GPROF algorithm does not retrieve TPW, only Rain Rate. Therefore, we have concentrated on Rain Rate, and we leave TPW for possible future algorithms (perhaps MIRS).

This year:

- 4--Enhanced the BRR and BTPW products to use MIRS Version 11 retrievals (which have both Rain Rate and TPW) which became available for GPM and several other satellites. We set up the real-time data feed for MIRS Version 11 and wrote code to ingest the data (in netCDF format) into DPEAS.
- 5--The Algorithm Readiness Review was held September 14, 2016.
- 6--The Operational Readiness Review was held February 1, 2017.
- 7--All code has been delivered to NESDIS/OSPO and is being implemented.
- 8--The image below shows which satellites contributed to a typical Blended Rain Rate (Blended TPW is similar). The important conclusion is that because of GPM's non-sunsynchronous orbit, it "shows" in the blended product (in which only the most recent observation is displayed) more frequently than many of the sunsynchronous do. Between 10% and 15% of the pixels are from GPM. Thus GPM significantly improves the blended products by providing more timely observations.
- 9--Final documentation and reports are currently underway as the project is nearing final completion.

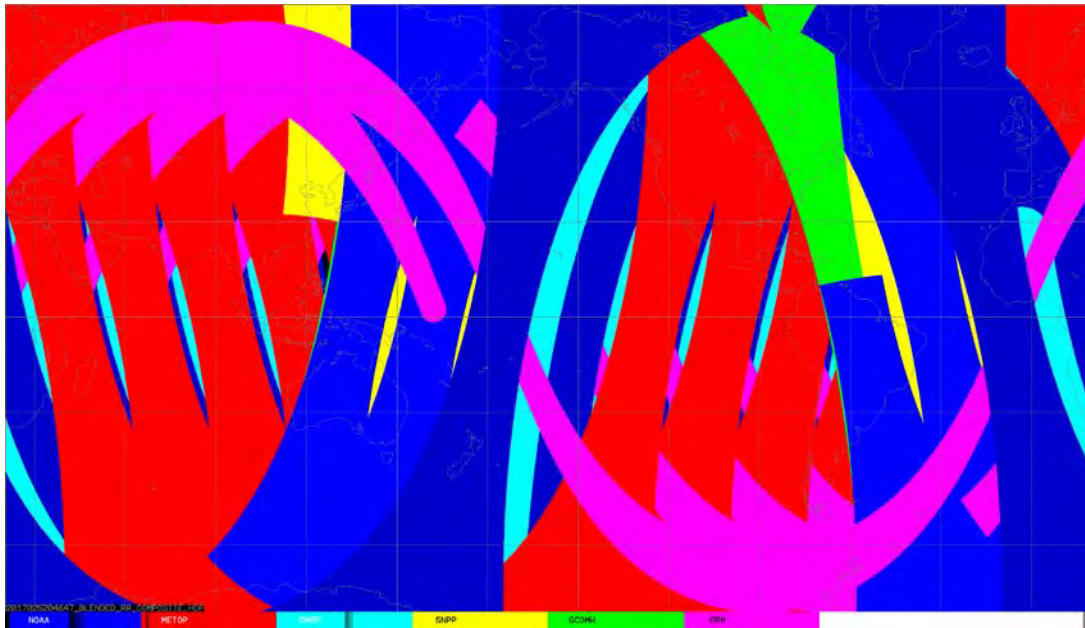

Figure 1. Satellites which contributed to one instance of Blended Rain Rate: Blue, NOAA 19; slightly darker blue, NOAA 18; red, MetOp-B; cyan, DMSP F18; yellow, Suomi NPP; green, GCOMW-1; magenta, GPM.

Publications:

Kidder, S. Q., J M. Forsythe, and A. S. Jones, 2016: Blended TPW Products Version 2.0: Algorithm Theoretical Basis Document (ATBD), November, 37 pp., in review.

Kidder, S. Q., J M. Forsythe, and A. S. Jones, 2016: Satellite Products and Services Review Board: Blended Rain Rate, Algorithm Theoretical Basis Document (ATBD), Version 2.0: November, 20 pp., in review.

PROJECT TITLE: Using JPSS Retrievals to Implement a Multisensor, Synoptic, Layered Water Vapor Product for Forecasters

PRINCIPAL INVESTIGATOR: John Forsythe

RESEARCH TEAM: Andy Jones, Stan Kidder, Dan Bikos, Ed Szoke

NOAA TECHNICAL CONTACT: Ralph Ferraro, NOAA/NESDIS/STAR Satellite Climate Studies Branch

NOAA RESEARCH TEAM: Ralph Ferraro (NOAA/NESDIS/STAR), Michael Folmer (Satellite Liaison at NOAA/NWS WPC/OPC/TAFB)

FISCAL YEAR FUNDING: \$125,000

PROJECT OBJECTIVES:

Research Objectives:

This JPSS/PGRR project began in August 2015 with an objective of developing new multisatellite, blended, layered water vapor products and delivering them to forecasters at national centers. To achieve this goal, NOAA Microwave Integrated Retrieval System (MIRS) satellite soundings from multiple polar orbiting spacecraft (NOAA-18/19, Metop-A/B, DMSP F18 and Suomi-NPP) are blended together every three hours to create a near-global, four-layer, four-dimensional view of precipitable water vapor. These products are highly complementary to the CIRA-developed blended total precipitable water (TPW), TPW anomaly and blended rain rate products which were successfully transitioned to NOAA operations in 2009 and are used throughout the NWS. Layered precipitable water (LPW) allows forecasters to understand the vertical distribution of water vapor not apparent from TPW, particularly over the data-sparse oceans. The product leverages the existing Data Processing and Error Analysis System (DPEAS) processing tool to enable seamless research-to-operations transitions.

Work in progress focuses on science investigations of how to perform advective blending of the product using model winds, to create a product at synoptic times. Blended LPW products are being delivered to national centers in near-realtime.

Achievements:

Precipitable water vapor in four layers (surface - 850 mb, 850 – 700 mb, 700 – 500 mb, and 500 – 300 mb) are created in near-realtime at CIRA and distributed to NOAA WPC, TAFB, NHC and OPC, via NASA SPoRT. A few additional SPoRT-partner weather forecast offices receive the products. Forecasters are using the products to support forecasting of heavy rains, as connections to tropical moisture serve to fuel extreme floods. The products are currently being used in a variety of forecast applications, including atmospheric rivers impacting the west coast and analysis of tropical waves in NHC tropical outlook discussions. The value of blended LPW in operations is demonstrated by this quote:

“LPW products have been available at the WPC since early 2015 and have proven to be a very useful diagnostic tool for operational forecasters at WPC’s Day 1 Quantitative Precipitation Forecast (QPF) and Metwatch desks. The WPC Metwatch desk’s primary responsibilities are to maintain continuous situational awareness of short-term heavy rainfall that may result in flash flooding, as well as ascertain potential impacts of atmospheric river events. The LPW has been utilized operationally at the Metwatch desk to identify areas of possible enhanced rainfall efficiency (e.g. warm rain and “seeder-feeder” processes) and query the depth of Pacific atmospheric rivers expected to impact the west coast of the continental U.S. It can also be utilized at WPC’s winter weather desk to assess lake effect snow potential by determining the depth of the moisture plume in conjunction with favorable cold air and trajectories over the lakes.”

-- Mark Klein, Science and Operations Officer, NOAA Weather Prediction Center (WPC)
12/17/16

An example use of CIRA blended LPW by the WPC is illustrated in Figure 1.

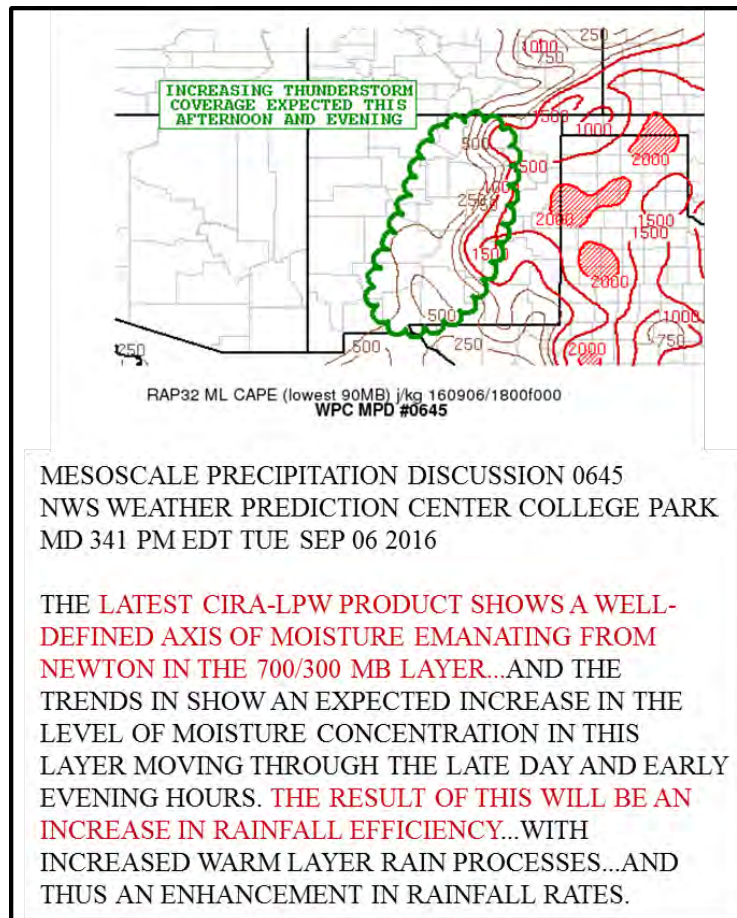

Figure 1. Example from WPC Mesoscale Precipitation Discussion #0645 illustrating the use of CIRA LPW for forecasting heavy rain in advance of the remnants of Hurricane Newton on 6 Sep. 2016, 1941 UTC.

The National Hurricane Center has become a heavy user of CIRA blended LPW to analyze the moisture environment around tropical waves and cyclones. For 28 days in July 2016, in Atlantic Tropical Weather Discussion (TWDAT), CIRA LPW was mentioned 45 times (out of 110 discussions).

A new application of CIRA LPW was developed by Michael Jurewicz (NWS Binghamton NY) for a heavy lake effect snow event (20 – 35" of snow), which was captured in a 30-minute VISIT chat session (audio and video available here: (http://rammb.cira.colostate.edu/training/visit/satellite_chat/20161215/)). In Michael's words:

" LPW data shines again, as the 700-500 mb panels show a lengthening moisture inflow, from the southeast coastal waters, all the way around the comma-head of the storm over northern New England/southern Ontario. Mid-level moisture is normally the Achilles heel of many otherwise good lake-effect events, but not so this time."

An advected blended LPW was developed in this year and is being produced experimentally in near-realtime. It will replace the overlay LPW which has been is currently being distributed to forecasters. The advected LPW uses Global Forecast System (GFS) winds to advect the LPW fields to a common time. Advected LPW is currently produced every three hours. Initial results indicate a more physical representation of moisture with intersatellite seams and gaps greatly reduced. In 2017, the advected LPW will be distributed to NOAA partners for additional comments and feedback to aid development. An example of the advected LPW for the four layers is shown in Figure 2.

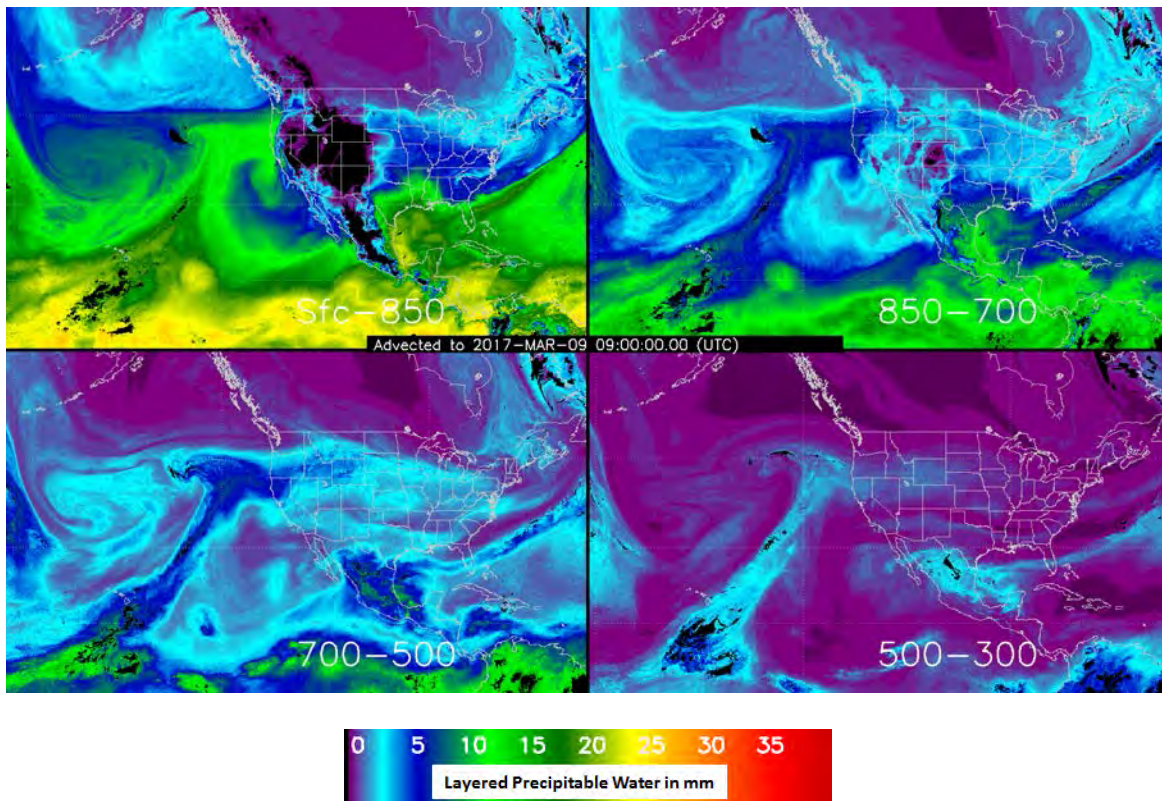

Figure 2. Version 01 advected CIRA LPW at four layers (sfc-850, 850-700, 700-500, 500-300) showing a strong atmospheric river at all levels affecting California. Advected to 09 UTC 09 March 2017. Black areas are missing due to topography or precipitation masking.

Publications: None

Presentations:

Forsythe, J.M., A. S. Jones, S. Q. Kidder, D. Bikos, E. Szoke, 2015: A Multisatellite Layered Water Vapor Product for Forecasters. Oral presentation at National Weather Association Annual meeting, Norfolk, VA September 2016.

REGIONAL TO GLOBAL SCALE MODELING SYSTEMS

Research associated with the improvement of weather/climate models (minutes to months) that simulate and predict changes in the Earth system. Topics include atmospheric and ocean dynamics, radiative forcing, clouds and moist convection, land surface modeling, hydrology, and coupled modeling of the Earth system.

PROJECT: ENVIRONMENTAL APPLICATIONS RESEARCH

FISCAL YEAR FUNDING (EAR Total): \$7,309,853

PROJECT TITLE: EAR - Flow-following Icosahedral Model (FIM) Development Project

PRINCIPAL INVESTIGATOR: Sher Schranz

RESEARCH TEAM: Ning Wang, James Rosinski, Jacques Middlecoff, Haidao Lin, Julie Schramm

NOAA TECHNICAL CONTACT: Stan Benjamin (OAR/ESRL/GSD/AMB Chief)

NOAA RESEARCH TEAM: Georg Grell (OAR/ESRL/GSD/MDB Chief), Jian-Wen Bao (OAR/ESRL/PSD), Mark Govett (OAR/ESRL/GSD/ATO)

PROJECT OBJECTIVES:

Tasks for this project include: developing and improving FIM for global and continental scale weather prediction, developing and implementing accurate and efficient numerical schemes for FIM on massive parallel computer systems, and designing and developing a data assimilation system for weather forecast.

PROJECT ACCOMPLISHMENTS:

A stochastically perturbed physics tendencies (SPPT) scheme, which perturbs the tendency from physics package using random patterns with specific stochastic characteristics, is implemented for FIM. Numerical experiment is currently being conducted to assess its impact on the spread of the ensemble forecast. Preliminary test shows some interesting and promising results for precipitation forecast.

A stochastic parameter perturbation (SPP) scheme designed by Georg Grell, which perturbs convective parameterization within the physics package using random patterns with similar stochastic characteristic, is implemented for FIM. The scheme can be used alone or together with SPPT scheme. The preliminary result shows that it increases the ensemble spread and 500mb height forecast skill when is used together with SPPT.

A new algorithm is being developed to generate the random pattern for SPPT (and SPP) on unstructured model grids directly. The new random pattern will soon be tested and evaluated with FIM SPPT and SPP implementation.

CIRA researchers continued to follow scientific developments with the GFS physics package from NCEP. Specifically, the NUOPC group has defined an init/run/finalize interface to the package and implemented it in the full GFS model. CIRA researchers are implementing this package in FIM. CIRA researchers continue to improve the computational performance of the FIM physics package.

A new data assimilation scheme for FIM has been proposed to correct the bias of the model initial condition. The preparation work for the project has been finished.

On the Next Generation Global Prediction System (NGGPS) side, CIRA researchers have started to test run FV3 using the model code from NCEP/EMC. The pre-processing and post-processing software has been modified and created to run on their super-computer. The pre-processing software generates FV3 initial condition from GFS spectral analysis and constant data files for current GFS spectral models. The post-processing software takes FV3 output on the native cubed sphere grid and produces output files on standard Cartesian grids in netCDF or GRIB format. These files can be used for model diagnosis analysis and forecast skill assessment.

PROJECT TITLE: EAR - Nonhydrostatic Icosahedral Model (NIM) Project

PRINCIPAL INVESTIGATOR: Sher Schranz

RESEARCH TEAM: Ning Wang, Ka Yee Wong, Thomas Henderson, Jacques Middlecoff, and James Rosinski

NOAA TECHNICAL CONTACT: Jin Luen Lee (OAR/ESRL/GSD/EMB)

NOAA RESEARCH TEAM: Jian-Wen Bao (OAR/ESRL/PSD), Mark Govett (OAR/ESRL/GSD/ATO)

The NIM model is no longer used for research at GSD. Research is now focused on global models that are used to evaluate the NWS global model such as the FIM and the NGGPS program.

PROJECT TITLE: EAR- High Performance Computing

PRINCIPAL INVESTIGATOR: Sher Schranz

RESEARCH TEAM: Jacques Middlecoff, James Rosinski, Ning Wang, Julie Schramm, Duane Rosenberg, Bryan Flynt

NOAA TECHNICAL CONTACT: John Schneider (OAR/ESRL/GSD/ATO)

NOAA RESEARCH TEAM: Mark Govett (OAR/ESRL/GSD/ATO)

PROJECT OBJECTIVES:

--Collaborate with ESRL meteorologists on the objective of running the Non-hydrostatic Icosahedral Model (NIM) at sub 5KM global resolution. Running at 5KM resolution requires accelerator technology and research in the area of grid generation and optimization, pre- and post-processing, and development of numerical algorithms. Running NIM at 5KM resolution also requires the enhancement of the software suite known as the Scalable Modeling System (SMS).

--Provide software support to ESRL scientists including software design advice and expertise on a variety of software/web/database technologies. CIRA researchers continue to modify the Flow-following, Finite volume Icosahedral Model (FIM) software and the Finite-Volume Cubed-Sphere (FV3) model.

--Serve on the National Unified Operational Prediction Capability (NUOPC) Common Model Architecture (CMA) and Content Standards (CSC) subcommittees.

--Fine-tune software engineering processes used during FIM development, ensuring that these processes remain suitable for a candidate production NWP code, optimize FIM run-time performance, port FIM to new machines, and incorporate new features such as the ongoing integration of WRF-CHEM and WRF-ARW physics into FIM.

--Assist the Space Weather Prediction Center in maintaining and improving the Ionosphere Plasmasphere Electrodynamics (IPE) code.

--Port FV3 to GPU (NVIDIA) and MIC (KNL) architectures and optimize without degrading performance on the CPU.

--For the operational FV3 and supporting utilities from NCEP, port, optimize and construct build and run scripts for ESSL research environment.

PROJECT ACCOMPLISHMENTS:

CIRA researchers continued to optimize serial and parallel NIM on NVIDIA GPU, Intel's® Xeon® Phi, and CPUs from Intel® and AMD®. They continued to use NIM as a test case to investigate the stability and features of new commercial OpenACC GPU compilers from Portland Group and Cray and for the Intel compiler for the Xeon Phi. Many compiler bugs and limitations were found and fed back to the vendors yielding improved products that better address our needs. CIRA researchers improved I/O and OpenMP performance of NIM. They repeatedly integrated major changes from the model developers onto the NIM trunk and parallelized for both distributed-memory parallel and fine-grained architectures.

CIRA researchers enhanced the capabilities of SMS including processor-to-processor communication (exchange). CIRA researchers enhanced SMS adding more support for the IPE code. CIRA researchers continue to assist SMS users and to find and fix bugs.

CIRA researchers assisted FIM developers with integration, parallelization errors, test suite issues, I/O issues, repository issues, interruptions in real-time runs, and general debugging. They assisted the FIM team with several time-critical tasks required to meet FIM project deadlines. They also created a test suite for the coupled FIM-HYCOM and FIM-CHEM systems which are now in regular use by model developers. CIRA researchers continued to extend and maintain the automated overnight continuous integration testing for FIM as new model features and parameterizations are added.

Seasonal forecasting with FIM-HYCOM is a priority in the Earth Modeling Branch (EMB) at ESRL. As such they use the "fim2nc" package developed by CIRA researchers to convert FIM output data to netCDF. CIRA researchers have continued to respond to updated needs of EMB scientists, such as the requirement to properly interpolate vector fields from FIM's icosahedral-hexagonal grid to a latitude-longitude grid.

CIRA researchers modified FIM to enable porting to the TACC computer facility in Texas to utilize a large time allocation for CPU and KNL hardware. This work allowed ESRL scientists to run coupled FIM-HYCOM simulations.

CIRA researchers continued collaborating with NCEP, Navy, NCAR, and NASA to define aspects of a Common Modeling Architecture (CMA) for the National Unified Operational Prediction Capability (NUOPC). The primary objective of the NUOPC's CMA is to reduce long-term costs of integrating and sharing software between the nation's three operational global weather prediction centers; Air Force Weather Agency (AFWA), Fleet Numerical Meteorology and Oceanography Center (FNMOC), and NCEP. They also served on the NUOPC Physics Interface to define APIs and conventions to allow easier sharing of physical parameterizations among NWP modeling systems. And they continued attending NCEP's bi-

weekly UMIG meetings to discuss ongoing upgrades to NEMS and ensure that FIM continues to be NEMS-compliant.

CIRA researchers participated as part of the Global Model TestBed (GMTB) to devise an Interoperable Physics Driver (IPD), which will allow developers of physical parameterization packages to more easily integrate and test their schemes into the FV3 model, which is the chosen dynamical core for the next generation Global Forecast System (GFS) at NCEP.

Scientists in the Earth Modeling Branch (EMB) at ESRL are working to enable alternative physics packages in global models. Current work involves implementing the HRRR (high-resolution rapid refresh) physics package in FIM and FV3. CIRA researchers are assisting in the software development aspects of this exercise. Examples including enabling support for the Lahey compiler, and ensuring bitwise identical results between offline (single time step, single-column mode) and online (full model) implementations.

CIRA researchers discovered and reported to NCEP an important coding bug in the GFS physics package, which is used by FIM, GFS, and FV3 numerical models. The bug involves a reversed vertical index into a dewpoint temperature array when precipitation type is being calculated. The manifestation of the bug is that for example when dewpoint is needed at the top model level, instead the dewpoint at the bottom model level is used.

CIRA researchers continued evaluating Intel's® Xeon® Phi (a.k.a. MIC, a.k.a. KNL) for the FIM and FV3 models. They continue to work closely with vendor assistance from Intel to tune performance of FV3 on Xeon Phi without adversely impacting performance on traditional CPU architectures.

CIRA researchers continued to improve software engineering processes for FIM and FV3.

CIRA researchers continued to assist the Space Weather Prediction Center in maintaining the Ionosphere Plasmasphere Electrodynamics (IPE) code. CIRA researchers did extensive work in optimizing the parallel performance of the IPE code including rewriting output routines. A major reason for poor parallel performance was load imbalance. Load imbalance was addressed in three ways. First, the gather of the variable poleVal was very costly and caused most processors to wait on a serial component. The time required for the gather of poleVal was greatly reduced by gathering only the small part of poleVal that was actually needed. Second, load imbalance due to unequal work was addressed by statically grouping the layout in the North/South direction so as to give each processor approximately the same number of flux tubes. Third, static day/night load balancing was added by making use of Intel Hyper-Threading and processor pinning to give each processor work from locations on opposite sides of the earth. These optimizations resulted in a 3X performance increase.

CIRA researchers assisted with the GSD transition from GSDForge to the NWS's VLab code management system. They assisted software engineers and scientists with the transition from SVN to the GIT version control system. The FIM test suite was also modified to use "git", a more full-featured source code maintenance tool than "subversion", which was used previously.

CIRA researchers ported preliminary versions of FV3 and supporting utilities from NCEP to NOAA machines "theia" and "jet". Scripts to build and execute the model were developed to be used in a research/code development environment. Utilities for model pre-processing and post-processing are being modified or created to run on theia and jet. Input data for FV3 can be created from GFS analysis data in spectral coefficient format. Output data from FV3 is processed for diagnostic analysis and forecast skill assessment. A test suite is being implemented for use at ESRL.

In addition to "theia" and "jet" ports mentioned above, CIRA researchers ported the FV3 model (including GFS physics package) to the new Xeon Phi (KNL-based) system at TACC (named "stampede"). Initial performance results are encouraging, with somewhat faster computational results than Haswell-based machine theia. MPI communication costs comparing theia to stampede are about the same.

Two CIRA researchers have recently been hired to work on High Performance Computing. One is collaborating with the Joint Effort for Data-assimilation Integration (JEDI) program by converting the existing Gridpoint Statistical Interpolation System (GSI) into object oriented modules. The other is working on the port of FV3 to the GPU and working on the FV3GFS test suite described above.

Initial work on the JEDI project involves an assessment of the computational performance characteristics of the existing GSI package. CIRA researchers have profiled the GSI for a representative test case on NOAA machine “theia”, and will be focusing on the computational performance of the embedded radiation package, CRTM. The CRTM is a very expensive component of the GSI.

As part of the strategy to enable FV3GFS to operate under a broad variety of environments (i.e., different compilers, versions) and to form the basis of production and development roles using the plethora of hardware architectures (e.g., with and without accelerators) characterizing available computing platforms, CIRA researchers have used NOAA's Dependency-Driven Test System (DDTS) software to set up a test suite for the FV3GFS code. The test suite allows regression and run-to-run testing for all types of runs desired for the code to ensure code quality, accuracy, and reproducibility, and is extensible enough to enable individual researchers to test regularly any new FV3GFS code or functionality that is added.

Since the strategic plan for FV3GFS requires its use under such broad operating conditions, CIRA researchers use advanced tools and techniques at the forefront of HPC development for enhancing the code's capability to run optimally on different platforms. CIRA researchers have worked closely with software and hardware vendors to ensure that these tools both perform as required and also accommodate modern language syntax and structure by providing them “codelets” that they can use to diagnose issues. This 'public-private' partnership has been viewed as highly successful in helping to bring some of these forefront technologies to maturity faster than would otherwise have been the case.

PROJECT TITLE: EAR – Rapid Update Cycle (RUC), Rapid Refresh (RAP) and High Resolution Rapid Refresh (HRRR) Assimilation Development and Enhancement

PRINCIPAL INVESTIGATOR: Sher Schranz

RESEARCH TEAM: Tracy Lorraine Smith, Haidao Lin, Steve Albers

NOAA TECHNICAL CONTACT: Stanley Benjamin (OAR/ESRL/GSD/ADB Chief)

NOAA RESEARCH TEAM: Curtis Alexander (OAR/ESRL/GSD/ADB), Steve Weygandt (OAR/ESRL/GSD/ADB)

PROJECT OBJECTIVE:

The primary focus of the GSD Assimilation Development Branch (ADB) is the refinement and enhancement of the Rapid Refresh (RAP), High Resolution Rapid Refresh (HRRR) and development of the Weather Research and Forecast (WRF) assimilation systems. In addition to refinement and enhancements of the RAP and HRRR, CIRA researchers collaborate on the development of the Weather Research and Forecast (WRF) model used by CIRA and GSD researchers. Support for the continued operation of the Rapid Update Cycle (RUC) was also conducted, with a major port to the Theia supercomputer and updates to data being ingested into the system.

The HRRR is a NOAA real-time 3-km resolution, hourly updated, cloud-resolving atmospheric model, initialized by 3km grids with 3km radar assimilation over a 1-h period (since 5 April 2013), adding further detail to the HRRR initial conditions otherwise determined by the hourly data assimilation from the 13km radar-enhanced Rapid Refresh.

The primary goal this year was to assimilate convective initiation information derived from GOES satellite data into the RAP and HRRR forecast systems.

PROJECT ACCOMPLISHMENTS:

For this year's research goals, GOES cloud-top cooling rate data provided by the University of Alabama Huntsville (UAH) have been assimilated into experimental versions of the Rapid Refresh (RAP) and High Resolution Rapid Refresh (HRRR) at GSD. Within this RAP modeling framework, the cloud-top cooling rate data are mapped to latent heating profiles and are applied as prescribed heating during the diabatic forward model integration part of the RAP digital filter initialization (DFI). A similar forward integration only procedure is used to prescribe heating in the HRRR one-hour pre-forecast cycle. For both the RAP and the HRRR, the GOES-satellite-based cloud-top cooling rate information is blended with data from radar reflectivity and lightning flash density to create a unified convective heating rate field. In the current HRRR configuration, four 15-min cycles of latent heating are applied during a pre-forecast hour of integration. This is followed by a final application of GSI at 3-km to fit the latest conventional observation data.

Previous work on this project has demonstrated that these cloud-top cooling rates can help with the location and intensity of storms in the RAP and HRRR systems. A retrospective period of June 22-23, 2016 was chosen to continue investigation of the use of cloud top cooling rates in partnership with other satellite derived convective initiation indicators in the HRRR forecasts. This period was quite active with severe storms, with numerous tornadoes and large hail reports over the period. The use of the CI probability in the HRRR was deemed successful enough to add it to the real time experimental HRRR run here at GSD in mid-October 2016. We will continue to evaluate the assimilation of the data with the variation in the vertical structure of the assumed heating profile using information on the cumulus clouds as derived from GOES.

The HRRR Version 2 and RAP Version 3 became operational at NCEP mid May 2016 with significant improvements to the assimilation and modelling components.

PROJECT TITLE: EAR - HRRR-based Ensemble Repository Maintenance and Rocoto End-to-end Workflow (DTC-Task)

PRINCIPAL INVESTIGATOR: Sher Schranz

RESEARCH TEAM: Isidora Jankov, James Frimel, and Jeff Beck

NOAA TECHNICAL CONTACT: Georg Grell (OAR/ESRL/GSD/MDB Chief)

NOAA RESEARCH TEAM: John Brown (OAR/ESRL/GSD/MDB), Ligia Bernardet (CIRES)

PROJECT OBJECTIVE:

For the purpose of testing and evaluation activities, it is critical to have diligent code management in place. One proposed testing and evaluation activity for Annual Operating Plan (AOP) 2016 uses the High Resolution Rapid Refresh (HRRR) system in an ensemble mode. The HRRR system consists of various software components including the GSI and hybrid ensemble data assimilation systems, WRF pre-processing (WPS), WRF-ARW dynamic core and the Unified Post Processor (UPP). To ensure coordinated research, development, and transition of new or enhanced techniques to operations for the various system components, it is critical to maintain a traceable history of the software used in the testing. Workflow management systems make executing large testing and evaluation activities more efficient through managing complex interdependencies and requirements. Running a HRRR ensemble is one such complex system that requires workflow management to effectively execute the large number of tasks. When factoring in pre-processing, including data assimilation, running the model itself, post-

processing, calculating verification scores, and visualizing the results, one “run” of the ensemble modeling system can entail hundreds of individual calls to different software system components and scripts. The complexity of the system makes the process of running an ensemble system onerous for an operational center and extremely hard for the research community to emulate.

For the purpose of supporting testing and evaluation activities in AOP 2016, it will be necessary to establish a mechanism for HRRR code maintenance. The DTC proposes using the existing HRRR code repository with branches to capture code changes/additions associated with a particular DTC testing activity.

GSD staff has access to the deterministic HRRR system that utilizes the Rocoto workflow. This workflow will be used as a starting point for development of a Rocoto workflow for the HRRR ensemble system. An expanded version of the workflow will also include visualization, MET verification, and probabilistic product generation adopted from the Short Range Ensemble Forecast (SREF) post-processing package. For AOP 2106, the workflow will be designed to run on the Theia (NOAA) and Yellowstone (NCAR) supercomputers, providing the DTC with options to perform experiments on either of the two supercomputers.

PROJECT ACCOMPLISHMENTS:

- Commits made to master RAP/HRRR repository of code modifications for implementation of LSM and PBL parameterization stochastic physics perturbations, including options to perturb:
 - hydraulic conductivity
 - soil moisture
 - turbulent mixing length
 - thermal and moisture roughness lengths
 - cloud fraction
 - Prandtl number limit
- HRRR ensemble Rocoto-based workflow established on Theia and Yellowstone supercomputers.

PROJECT TITLE: EAR - Refinement and Evaluation of Automated High-Resolution Ensemble-based Hazard Detection Guidance Tools for Transition to NWS Operations (GSD-Task)

PRINCIPAL INVESTIGATOR: Sher Schranz

RESEARCH TEAM: Isidora Jankov

NOAA TECHNICAL CONTACT: Georg Grell (OAR/ESRL/GSD/MDB Chief)

NOAA RESEARCH TEAM: Trevor Alcott, Curtis Alexander (OAR/ESRL/GSD/MDB)

PROJECT OBJECTIVE:

The overarching goal of this work is to transition a well-tested system for generation of ensemble post-processed hazard guidance products to operational status within the National Weather Service (product generation within NCEP and dissemination of hazard grids to NWS operational forecasters). A direct outcome of the project will be improved ensemble hazard guidance tools for operational forecasters that will reduce the ensemble information overload problem and enable a more efficient and accurate characterization of forecast uncertainty. Ultimately, the quality and usefulness of the weather guidance information provided by the NWS to the public will increase. Success in this project will also enable follow-up work to significantly expand the scope of ensemble hazard guidance product generation.

A main objective for this project is to expand an existing model-ensemble probabilistic product generation capability into a set of algorithms for creating a variety of different automated model ensemble-based hazard guidance tools that will be of maximum utility to NWS forecasters. The existing capability uses a time-lagged sequence of successive HRRR output grids, more details on the algorithm and how it will be adapted in this project are included in the next section. The idea is to develop a continuum of automated hazard-specific guidance tools, ranging from pure probabilistic guidance (e.g., probability of rain or snow rate exceeding a certain threshold, probability of freezing rain accumulation exceeding a certain threshold, probability of thunderstorm surface winds exceeding a certain threshold, etc.) to automated application of more geometric feature detection algorithms (e.g., identifying persistent edges of heavy snow bands, identifying tracks of large values of updraft helicity indicative of rotating thunderstorms and a potentially enhanced risk of tornadoes, etc.). Figure 1 provides an example of this approach for the New England blizzard of 27 Jan. 2015. The storm posed a significant forecast challenge as a very sharp western edge of the heavy snow shield was forecast across the densely populated New York City metropolitan area, with large variation among many different models. As can be seen in Fig. 1, the 12-h HRRR time-lagged ensemble (HRRR-TLE) probability forecasts of a heavy snowfall rates indicated the sharp western edge of the heavy snow, and, in turn, correctly predicted the western edge to the east of New York City.

PROJECT ACCOMPLISHMENTS:

- Coordination meeting amongst participating organizations to ensure roles, responsibilities, reporting, etc. (GSD, EMC, NCAR, WPC, WFOs).
- Quarterly presentations and reports to OAR,
- Secured second year funding based on the first year's accomplishments,
- Meeting deliverables in timely manner,
- 41 probabilistic products produced in real time and available at: <https://rapidrefresh.noaa.gov/hrrr/hrrrtle/>

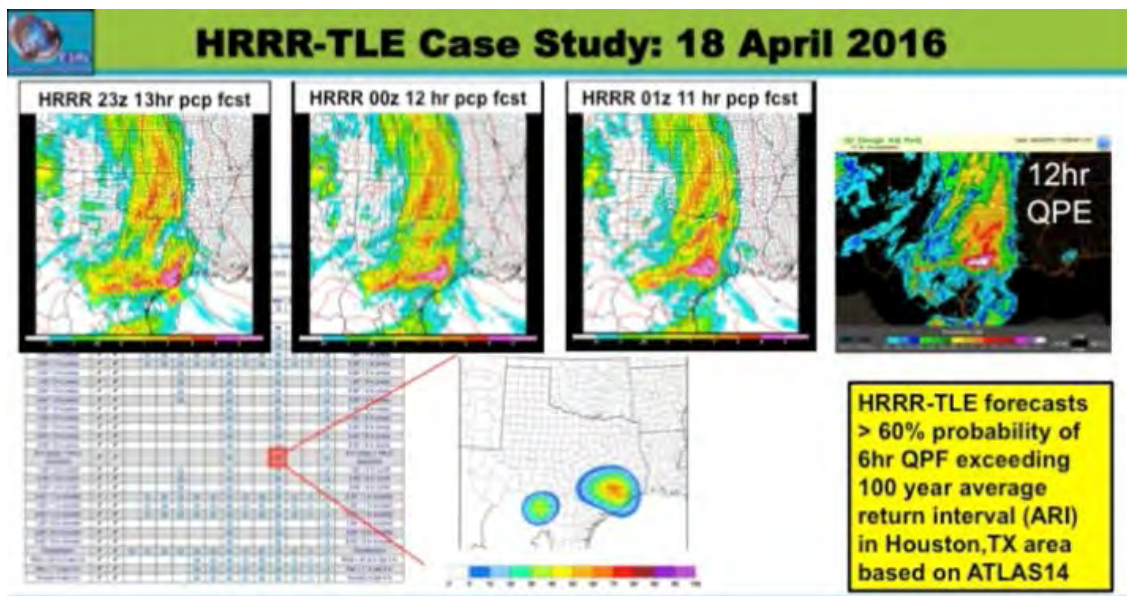

Figure 1. 12-h HRRR time-lagged ensemble (HRRR-TLE) probability forecasts of a heavy snowfall rates indicated the sharp western edge of the heavy snow, and, in turn, correctly predicted the western edge to the east of New York City.

PROJECT TITLE: EAR - Addressing Model Uncertainty through Stochastic Parameter Perturbations within the HRRR Ensemble (DTC-Task)

PRINCIPAL INVESTIGATOR: Sher Schranz

RESEARCH TEAM: Isidora Jankov, Jeff Beck, James Frimel, Hongli Jiang

NOAA TECHNICAL CONTACT: Georg Grell (OAR/ESRL/GSD/MDB Chief)

NOAA RESEARCH TEAM: John Brown (OAR/ESRL/GSD/MDB)

PROJECT OBJECTIVES:

In most existing regional ensemble systems, model-related uncertainty is addressed by using multiple dynamic cores, multiple physics suites, or a combination of these two approaches. While these approaches have demonstrated potential, it is time-consuming and costly to maintain such systems, especially in operations. In order to move toward a more sustainable and unified system, the DTC proposes to test an option based on an extensively tested physics suite combined with stochastic parameter perturbations on a set of physics parameterizations within that suite.

There has been considerable work on introducing stochastic physics into large-scale models, particularly for long-range and seasonal forecasts, but use of a similar approach in high-resolution, short-range models has been somewhat limited. The proposal for Annual Operating Plan (AOP) 2016 is to investigate the impact of a stochastic physics parameter perturbation approach within a convection-resolving ensemble at 3-km grid spacing.

The latest version of the WRF-ARW core includes an option for generation of a field of random perturbations that can be applied to parameters in physics schemes. The stochastic pattern is centered on zero and has a user-prescribed standard deviation. With this option, the user can specify the random perturbation length-scale, temporal de-correlation of the randomly perturbed field, and the vertical structure of the random perturbations. During the AOP 2015, the DTC ensemble team worked closely with the Rapid Refresh (RAP) physics developers to implement stochastic perturbations into several RAP physics parameterizations. Multiple experiments were performed comparing performance between a RAP ensemble created by using stochastic parameter perturbations in a variety of RAP physics schemes and a RAP ensemble that involved mixed physics. To this end, stochastic parameter perturbations were applied to parameters within the Grell-Freitas convective scheme, MYNN Planetary Boundary Layer (PBL) scheme and the RUC Land Surface Model (LSM). In addition, impact of stochastic perturbation approaches such as SKEB and SPPT were explored too. Results were very encouraging and motivated a continuation and expansion of this work.

To facilitate a similar effort at storm-scale resolutions for a rapid refresh ensemble, the DTC proposed to test stochastic parameter perturbations, as well as, impact of the SKEB and SPPT approaches within the High-Resolution Rapid Refresh (HRRR) framework. The focus for this testing was on PBL and LSM processes. Once again, the team worked in close collaboration with the developers of the physical parameterizations. This collaboration facilitated the process of identifying parameters of interest and adequate perturbation ranges. Performance of the HRRR ensemble with stochastic parameter perturbations has been evaluated in terms of bias, skill, accuracy, reliability and sharpness.

PROJECT ACCOMPLISHMENTS:

Primary focus of the SPP approach was to target improvement of the ensemble performance for near-surface variables (e.g. 2-m temperature, 2-m mixing ratio and 10-m wind) by introducing perturbations to a specific parameter or a set of parameters. Multiple experiments were performed with a focus on PBL scheme and finding optimal spatial and temporal de-correlation lengths. Selected spatial and temporal scales were 150 km and 6 hr, respectively. Simulations performed were 24-hr long and included four

cases all initialized at 06 UTC. HRRR-based ensemble consisted of 8 stochastically perturbed members. For these tests a variety of parameters within MYNN PBL was perturbed. The perturbations included:

- Mixing length, with a magnitude of 30%
- Aerodynamic roughness length, with magnitude of 30%
- Thermal/moisture roughness length, with magnitude of 30%
- Mass fluxes with magnitude of 20%
- Prandtl number limit 2.5 +/- 1 (only for stable conditions)
- Cloud fraction with magnitude of 20% and negatively correlated relative to mixing length.

The idea behind perturbing parameters with correlations described above was to tap into a feedback presented in Figure 1.

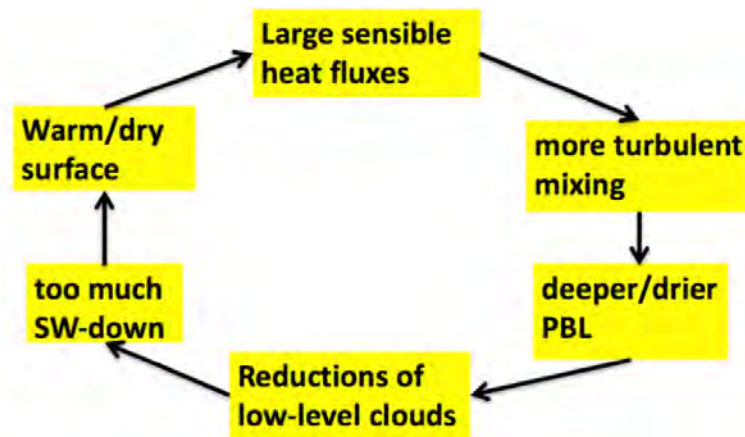

Figure 1. Physical feedback

In addition, effects of combining SPP with SKEB and SPPT were tested. An example of spread/skill relation for 10-m wind when all three stochastic approaches are combined is presented in Figure 2.

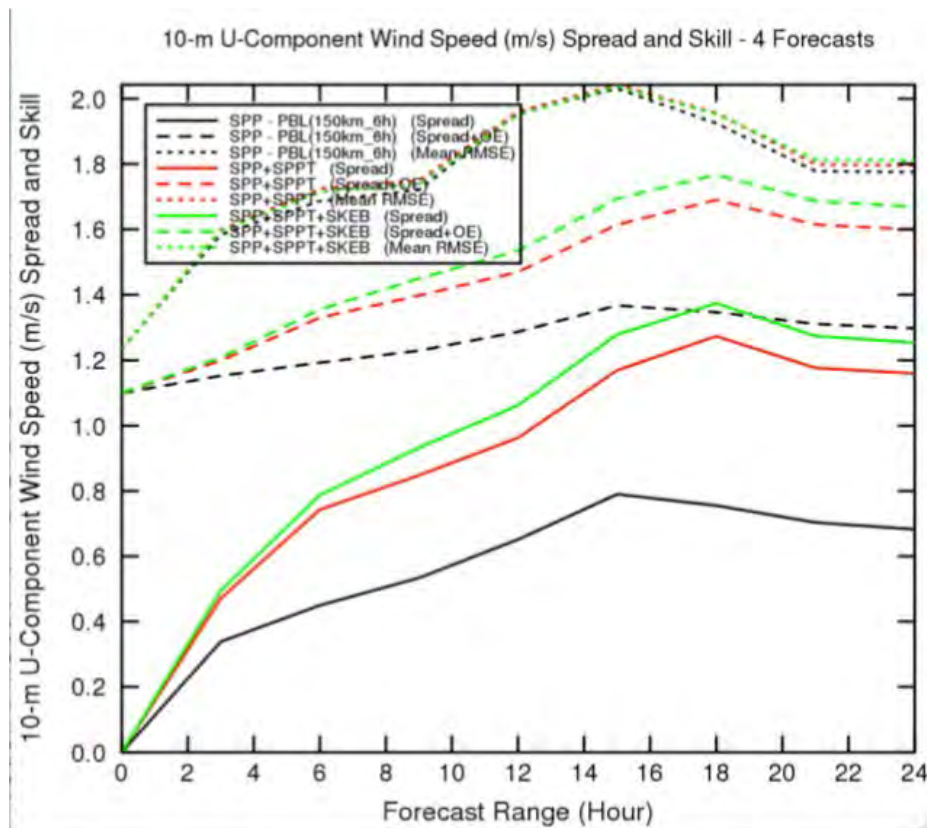

Figure 2. Ensemble spread (solid lines), ensemble spread with observational error included (long dashed lines), and the ensemble mean RMSE (short dashed lines) for SPP, SPP+SPPT and SPP+SPPT+SKEB experiments, for 10-m wind and for four simulations initialized at 0600 UTC.

Figure 2 shows that SPP PBL perturbations alone did not produce sufficient spread. However, the spread is substantially increased by application of SPPT and furthermore by combination of all three stochastic approaches together. At the same time, there was a very limited difference in RMSE between different experiments. These specific results and results from other extensive testing were in an agreement with results obtained when RAP-based ensemble was used. It was found that SPP alone does not produce sufficient spread while when combining stochastic approaches together, spread was substantially increased (Jankov et al., 2017).

Based on numerous tests that included the 4 cases, a configuration for the final 10-day retro run was selected. The final configuration includes a combination of PBL parameter perturbations (showed above) combined with SPPT and SKEB, and initial time soil moisture perturbation within the LSM scheme. The next step is to execute 8-member HRRR ensemble, 24-hr long simulations, twice a day (0000 UTC and 12000 UTC) for 10 days during Spring of 2016 (May 18-27, 2016). This period was characterized with intensive convective and severe weather. For the same period a control mixed-physics ensemble, that involves combination of different PBL and LSM schemes was created. Also, Storm Scale Ensemble of Opportunity (SSEO) data for the period of interest were obtained. The stochastic ensemble performance will be evaluated against both the control mixed-physics ensemble and SSEO. Obtained results will be summarized in a peer reviewed journal publication.

PROJECT TITLE: EAR - RAP and HRRR 4DEnVar Testing and Evaluation

PRINCIPAL INVESTIGATOR: Sher Schranz

RESEARCH TEAM: Jeff Beck

NOAA TECHNICAL CONTACT: Georg Grell (OAR/ESRL/GSD/MDB Chief),

NOAA RESEARCH TEAM: John Brown (OAR/ESRL/GSD/MDB), Ming Hu (CIRES)

PROJECT OBJECTIVES:

NCEP's transition from the GSI three-dimensional (3D) variational data assimilation (DA) system to the GSI-EnKF 3D hybrid DA system for its Global Forecast System (GFS) produced significant improvements in forecast skill. Following on the global application success, a number of regional applications have transitioned to one-way 3D hybrid ensemble-variational systems that use the GFS ensemble (e.g., NAM, HRRF, RAP). A number of operational centers (e.g., UK Met Office, Environment Canada) have implemented four-dimensional Ensemble-Variational (4D EnVar) DA toward further improved initial conditions for their global models. Such a DA system is slated for future implementation at NCEP, and therefore conducting EnVar DA tests is critical to being able to make effective contributions to this effort.

Therefore, the objective of this work is to use hourly GFS ensemble forecasts to test and evaluate 4D hybrid EnVar capabilities for high-resolution regional DA in the RAP and HRRR. The first objective of this activity will be to demonstrate whether a 4D hybrid EnVar system can improve upon the performance of the benchmark RAP and HRRR systems. To this end, experimental 4D hybrid EnVar systems, including workflows based on the operational NOAA RAP and HRRR systems will be set up. Then, hourly cycled 4D hybrid EnVar will be tested for comparison to benchmark control runs using the 3D hybrid system with the current RAP and HRRR DA configuration. Based on results from these experiments, the analysis update frequency will be updated from hourly to sub-hourly using a HRRR ensemble based on GFS ensemble initial condition perturbations. Appropriate observation and background files will be collected and adapted for a fast cycling system, and experiments performed to evaluate the impacts of increasing update frequency on the analysis and forecasts. Verification metrics accepted for operational relevancy will be used.

PROJECT ACCOMPLISHMENTS:

A 4D hybrid EnVar workflow was set up for both the RAP and HRRR systems to incorporate hourly GFS ensemble forecasts for use in DA, with appropriate code modified. Then, a 3DEnVar simulation using hourly GFS ensemble forecasts was conducted for both the RAP and HRRR for seven days from September 3rd to 10th, 2016 in order to have a comparison baseline for the 4DEnVar tests. First, the 4D hybrid EnVar testing for the RAP was run during the seven-day period and compared to the 3D hybrid EnVar benchmark (Figure 1).

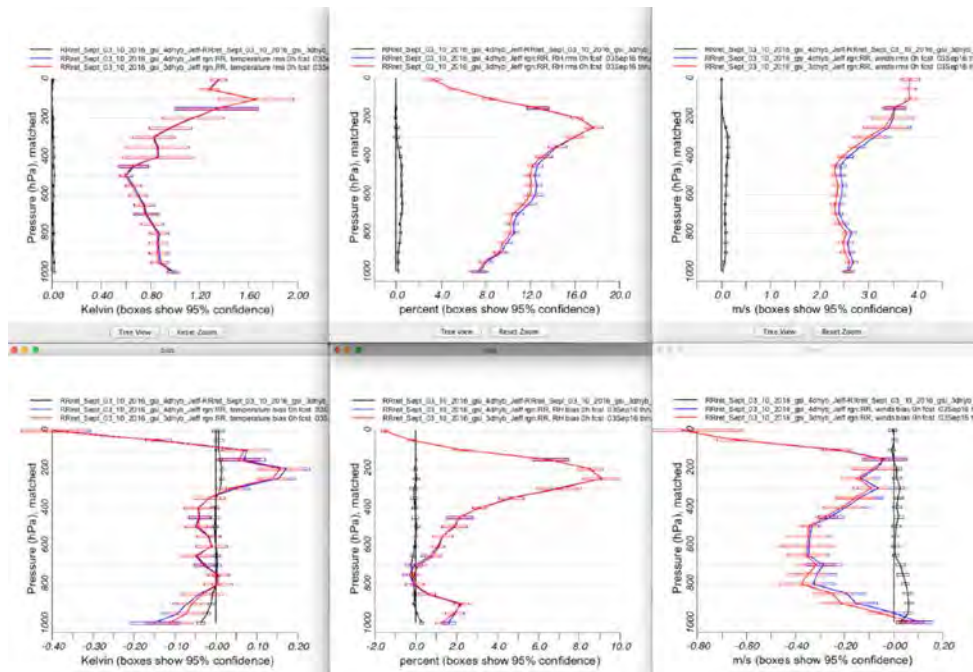

Figure 1. RMSE (top) and bias (bottom) for 0-hr forecasts for vertical profiles of temperature (left), relative humidity (center), and wind speed (right) for RAP simulations using 3D hybrid EnVar DA (red) and 4D hybrid EnVar DA (blue) for the period 3 Sep 2016 to 10 Sep 2016.

Analysis time vertical profile results show that the 4D hybrid EnVar simulation compares very closely to that of the 3D hybrid EnVar simulation of the RAP. RMSE values appear to be slightly better for the 3D hybrid EnVar simulations for relative humidity and wind speed, however these differences are not statistically significant. Bias is also similar between the two configurations, with 3D hybrid EnVar showing smaller bias near the surface for temperature, and the 4D hybrid EnVar configuration containing smaller bias at lower levels for wind speed. Once again, these differences are not statistically significant.

Verification of the 0-hr surface fields of temperature, relative humidity, and wind speed (Figure 2) show that RMSE is nearly identical between the 3DEnVar and 4DEnVar configurations. While bias is very similar between the two simulations for temperature and wind speed, relative humidity verification indicates that the 3DEnVar simulation had mostly lower bias.

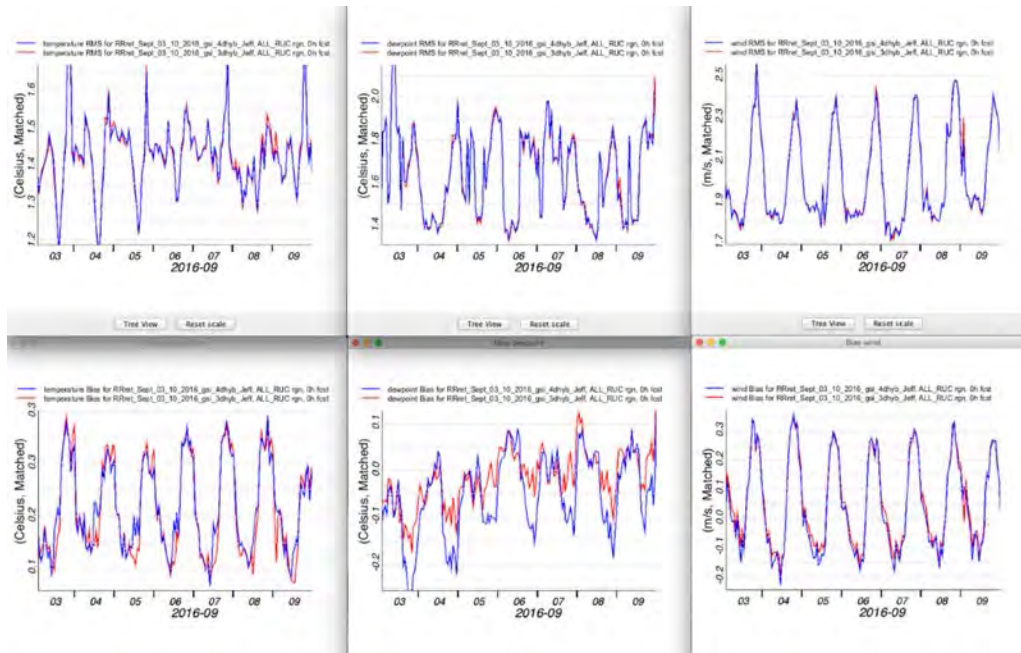

Figure 2. RMSE (top) and bias (bottom) for 0-hr surface forecasts of temperature (left), relative humidity (center), and wind speed (right) for RAP simulations using 3D hybrid EnVar DA (red) and 4D hybrid EnVar DA (blue) for the period 3 Sep 2016 to 10 Sep 2016.

Three-hour forecast verification (not shown) highlights nearly identical RMSE and bias for both the vertical profiles and surface forecasts for all three variables, indicating a rather quick convergence for forecast results between the 3DEnVar and 4DEnVar configurations.

It is important to note that GSD verification naturally favors the 3DEnVar setup because it is conducted at a single time period (the analysis time), while the 4D hybrid EnVar system incorporates three time levels (the analysis time and one hour before and after the analysis) to create the initialized state. Because of this discrepancy, new verification techniques are being developed to compare the 3DEnVar and 4DEnVar configurations on a more equal basis.

Results from the 4DEnVar HRRR retro using hourly GFS ensemble data are forthcoming and should be complete by the end of February 2017. Finally, a second 4DEnVar HRRR retro using sub-hourly HRRR ensemble data for DA is currently being set up and will be tested to assess the impact of sub-hourly DA on analysis and forecast accuracy. These results will be available by the end of March 2017.

PROJECT TITLE: EAR - Implementation and Testing of the Grell-Freitas Convective Parameterization in the NOAA Environmental Modeling System-based Global Spectral Model (GMTB-Task)

PRINCIPAL INVESTIGATOR: Sher Schranz

RESEARCH TEAM: Hongli Jiang

NOAA TECHNICAL CONTACT: Georg Grell (OAR/ESRL/GSD/MDB Chief)

NOAA RESEARCH TEAM: Ligia Bernardet (CIRES), Judy Henderson (OAR/ESRL/GSD/ADB), Man Zhang (CIRES)

PROJECT OBJECTIVES:

The overarching goal of this work is to implement and test the Grell-Freitas convective parameterization in the NOAA NEMS based Global Spectral Model. This parameterization was selected for testing by Environmental Modeling Center (EMC) and by the Program Office of the NOAA Next-Generation Global Prediction System (NGGPS) because of its potential for improving forecasts. The primary conceptual advantages of the GF scheme over the Simplified Arakawa Schubert (SAS) which is currently used in the GFS operational forecast are its scale-aware features, which make the scheme suitable for use in a wide range of model resolutions, and its stochastic approach to the representation of convection, which improve the forecast by using a collection of parameters and algorithms to represent the convective triggers and closures (Grell and Devenyi 2002). An additional factor that led to this choice was the scheme's maturity, its history of operational use at NCEP for a regional application, and the fact that its development is funded by NGGPS.

The Global Model Test Bed (GMTB) is a new entity formed within the Developmental Testbed Center in 2015 to support transition of research to operations for the NCEP global model development under the auspices of NGGPS.

PROJECT ACCOMPLISHMENTS:

We implemented the GF parameterization in a developmental version of the NOAA Environmental Modeling System (NEMS)-based Global Spectral Model (GSM), and ran experimental retrospective forecasts using the NEMS-GSM over a warm (June, July, August 2016) season.

The testing and evaluation of the GF scheme versus SAS are focused on the physical interpretation of the statistical verification. In depth analysis of the impact of convective parameterization on surface precipitation and other fields of interest are performed. The goal of these analyses is to learn the strength and weakness, and improve the scheme in collaboration with the GF developers, G. Grell of OAR/ESRL/GSD. Special attention has been given to the partition of convective versus grid scale precipitation, and to the distribution of total precipitation over land and ocean.

Preliminary results have been presented at various meetings and workshops. Selected results are included in here.

schemes	Global average		Average over the Tropics (20S – 20N)			
	Total	Convective	Convective (land+ocean)	Land (Conv)	Ocean (conv)	Frac (%) (Conv/tot)
SAS (op)	2.81	1.53	4.41	2.89	4.87	86.7
SAS (2)	2.90	1.61	4.57	4.58	4.57	87.3
GF (v3a)	2.74	1.07	3.66	2.58	3.99	70.5
GF (v3b, imid=0)	3.05	1.56	5.35	2.49	6.22	86.6
GF (v3b, imid=1)	3.03	1.54	5.29	2.42	6.17	86.5

Table 1. Comparisons of surface precipitation rate (24 h avg mm/day), SAS (operational), SAS (imfdepcnv=2, future release), GF (v3a, best performance), v3b (tuning experiment). Turning on (imid=1), and off (imid=0) the modeled convective clouds in the mid-level of atmosphere.

PROJECT TITLE: EAR - Improving Short-Range Forecasts of Severe Weather and Aviation Weather from Enhancements to the Assimilation of Satellite Infrared Radiance Data from SEVIRI and GOES-R ABI

PRINCIPAL INVESTIGATOR: Sher Schranz

RESEARCH TEAM: Haidao Lin, Ning Wang

NOAA TECHNICAL CONTACT: Stan Benjamin (OAR/ESRL/GSD/ADB Chief)

NOAA RESEARCH TEAM: Steven Weygandt (OAR/ESRL/GSD/ADB), Yuanfu Xie (OAR/ESRL/GSD/ADB)

PROJECT OBJECTIVE:

Investigate the impact from satellite hyperspectral and infrared data on severe storm forecasts in the Rapid Refresh and global models and the increase in accuracy of short-range mesoscale model forecasts from the assimilation of satellite data into the Rapid Refresh and global models

PROJECT ACCOMPLISHMENTS:

Over the past year, work has continued on 1) evaluating the radiance data impact within the Rapid Refresh (RAP) version 3; 2) preparing for the radiance updates for the coming RAPv4; 3) starting the work towards building the Global Rapid Refresh data assimilation model system.

The study on the satellite radiance data impact within the framework of RAPv3 has been completed through a series extensive one-month retrospective runs. Figure 1 shows the normalized 1-18 h forecast RMSE reduction (against radiosonde data, 1000-100 hPa averaged) of Regional ATOVS Retransmission Services (RARS) data denial (blue) and all-radiance data denial (red) runs compared with the CNTL. We note that due to having the longest time since the last partial cycling, stronger data impact could be anticipated at 6-h and 18-h duration. It can be seen that radiance data have a very consistent small positive impact for all variables (temperature, relative humidity, and wind) and for all forecast lead times

(1-18 h) with confidence at the 95% level. For temperature, the normalized impact is from 0.7%-1.6%; for relative humidity, the normalized impact is from 0.7%-1.1%; for wind, the normalized impact is from 1.0%-1.6%. A journal paper (Lin et al. 2017a) based on this data impact study has been submitted to and accepted by *Weather and Forecasting*.

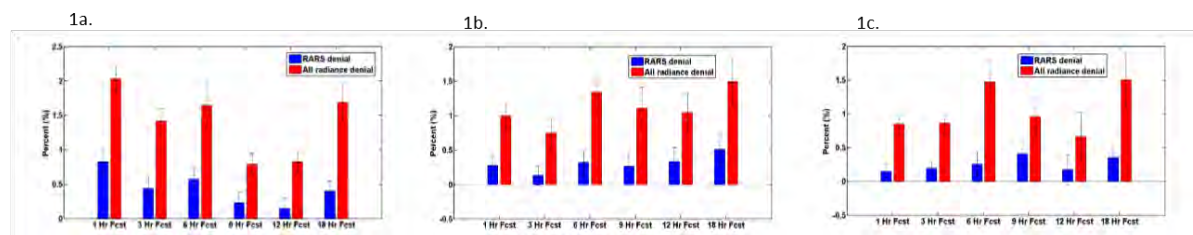

Figure 1. Normalized RMSE reduction $[(EXPT - CNTL)/CNTL]$ [(1a) temperature (K), (1b) relative humidity (%), (1c) vector wind magnitude ($m s^{-1}$)] from the RARS denial run (blue) and all-radiance denial run (red) 1-18 hour forecasts against rawinsonde observations. Statistics are computed for 1000-100-hPa layer over the RAP domain. The retrospective period is from 1-31 May 2013. The error bar indicates the ± 1.96 standard error from the mean impact, representing the 95% confidence threshold for significance.

In preparation for the radiance upgrade for coming RAPv4 (planned implementation at the early of 2018), we've done some work to include and evaluate the data impact within RAP from new data sets. We plan to include quite some new radiance data sets for RAPv4, including SEVIRI from M10, ATMS/CrIS from NPP, SSMIS from DMSP-17, IASI from METOP-A/B, AIRS/AMSU-A from AQUA, and possible ABI radiance data from GOES-16 (when operationally available). We've performed some initial work (data coverage checking, preliminary channel selection, bias correction evaluation, preliminary retrospective testing) and got some preliminary data impact results from these new data sets (except for the ABI from GOES-16). A series of 7-day RAP retrospective runs are conducted with the control run assimilated all available conventional and satellite radiance data in RAPv3 and experiment runs added SEVIRI data only, ATMS from NPP only, CrIS from NPP only, SSMIS from DMSP-17 only, IASI from METOP-A/B only, AIRS/AMSU-A from AQUA only, and all the above new data combined together. Figure 2 shows the normalized RMSE reduction $[(CNTL - EXPT)/CNTL]$ (%) [(upper left) temperature, (upper right) relative humidity, (lower left) vector wind magnitude] from different experiments (SEVIRI only, ATMS only, CrIS only, SSMIS only, IASI only, AIRS/AMSU-A on Aqua only, and all new data added) 18 hour forecasts against rawinsonde observations. It can be seen that IASI data have the largest positive impact with statistical significance for temperature among these new data sets and the all data sets have positive impact ($\sim 0.5\%$ - 1% improvement) with statistical significance for temperature, moisture, and wind. The work towards the radiance upgrade for RAPv4 is underway. It is expected that the new satellite radiance data will continue to have added benefits for the forecast skills within RAP. We plan to have RAPv4 ready in a year and we will incorporate the GOES-16 ABI infrared data into the new RAPv4, to evaluate the additional benefits from the high temporal and horizontal resolution ABI data.

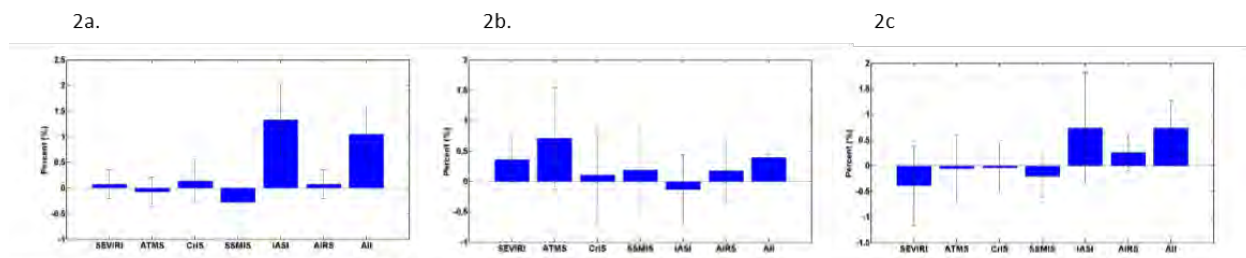

Figure 2. Normalized RMSE reduction $[(\text{CNTL} - \text{EXPT})/\text{CNTL}]$ (%) [(2a) temperature, (2b) relative humidity, (2c) vector wind magnitude] from different experiments (SEVIRI only, ATMS only, CrIS only, SSMIS only, IASI only, AIRS/AMSUA on Aqua only, and All new data added) 18 hour forecasts against rawinsonde observations. Statistics are computed for 1000-100-hPa layer over the CONUS domain. The retrospective period is from 1-7 December 2016. The error bar indicates the ± 1.96 standard error from the mean impact, representing the 95% confidence threshold for significance.

Finally, we have started the work toward building a global rapid refresh model system. As one of first steps to set up the global rapid refresh, The GSD cloud analysis package has been successfully applied to 6-h cycled GFS/GDAS with short-range forecasts only (up to 24-h for now). We've conducted 7-day GFS/GDAS retrospective runs with and without the GSD cloud analysis using the operational GFS/GDAS version in 2015. Then we furthered to work on the development of the global rapid refresh based on the GSD Flow-following finite-volume Icosahedral Model (FIM) and NCEP GSI analysis package. Some progress had been made on this and this work has been pending now due to the dynamic core selection for the NGGPS (Next Generation Global Prediction System). We plan to resume this work by incorporating the selected FV3 dynamic core instead of the FIM into the global rapid refresh framework.

PROJECT TITLE: EAR – Model Evaluation

PRINCIPAL INVESTIGATOR: Sher Schranz

RESEARCH TEAM: Bonny Strong, Randy Pierce

NOAA TECHNICAL CONTACT: Stan Benjamin (NOAA/ESRL/GSD/ADB Chief)

NOAA RESEARCH TEAM: Steve Weygandt (OAR/ESRL/GSD/ADB)

PROJECT OBJECTIVE:

Support verification needs for NWP model development within GSD.

PROJECT ACCOMPLISHMENTS:

Project accomplishments during this year have included:

- Submitted a proposal for funding under the NWS Next Generation Global Prediction System program to support development of a Unified Verification System for use at NCEP/EMC, the Developmental Testbed Center (DTC), and GSD.

- Prepared a project plan for funding received under NOAA Generation Global Prediction System (NGGPS).

- Interviewed about 50 users at NCEP/EMC in order to compile and prioritize requirements for the NNGGPS Unified Verification and submission of that report to NNGGPS and EMC.
- Provided leadership to the verification team at GSD/Environmental Modeling Branch (later GSD Assimilation Development Branch (ADB) after reorganization of Oct 1, 2017) to support model development efforts. This has included:
 - Establishing an issue management system within NOAA's VLab to track ongoing support needs for existing verification system;
 - Managing project to replace existing web applications based on java applets with web technology;
 - Managing a project to build an enhanced verification system in support of work for model improvement in the Wind Forecast Improvement Project 2 (WFIP2) that included more detailed diagnostic information than was available in existing verification application;
 - Providing major contributions to hiring a new verification staff member
- Acted as liaison with the IT Services branch to manage the migration of GSD's EMB (ADB/MDB) applications off old, unsupported hardware onto new infrastructure.
- Initiating and overseeing a project to clean up web applications and move them into a new organizational structure on new VM infrastructure.
- Serving as Section Lead of the Assessment Section within the newly formed Assimilation Development Branch, including participating in leadership team meetings of ADB and jointly with the Modeling Development Branch (MDB).
- Leading efforts to investigate new NoSQL database technology as a possible alternative to existing MySQL relational database usage.

EAR Publications:

Alcott, T., I. Jankov, C. Alexander, S. Weygandt, S. Benjamin, J. Carley, and B. T. Blake, 2017: Calibrated, probabilistic hazard forecasts from a Time-Lagged Ensemble. 33rd Conf. on Environmental Information Processing Technologies, Seattle, WA, Amer. Meteor. Soc. (Recorded Presentation available at: <https://ams.confex.com/ams/97Annual/webprogram/Paper311242.html>)

Alcott, T., C. Alexander, S. Albers, R. Ahmadov, E. James, S. Benjamin, and S. Weygandt, 2017: HRRR-AK: A High-Resolution, Rapidly Cycled Forecast Model for Alaska. 28th Conference on Weather Analysis and Forecasting/ 24th Conf. on Numerical Weather Prediction, Seattle, WA, Amer. Meteor. Soc. 615. (Available online at: <https://ams.confex.com/ams/97Annual/webprogram/Paper306923.html>)

Alexander, C., T. Alcott, I. Jankov, S. Weygandt, and S. G. Benjamin, 2017: Ensemble Prediction with the High-Resolution Rapid Refresh (HRRR): Providing Probabilistic Forecasts of Weather Hazards for Aviation. 18th Conference on Aviation, Range, and Aerospace Meteorology, Seattle, WA, Amer. Meteor. Soc. (Recorded Presentation available at: <https://ams.confex.com/ams/97Annual/webprogram/Paper313352.html>)

Beck, J., I. Jankov, H. Jiang, J.K. Wolff, M. Harrold, J. Frimel, and L. Carson, 2017: An Evaluation of Stochastic Physics Within the High Resolution Rapid Refresh (HRRR) Ensemble and the Impacts of High Performance Computing (HPC). 3rd Symposium on High Performance Computing for Weather, Water and Climate, Seattle, WA, Amer. Meteor. Soc, 1441. (Available at: <https://ams.confex.com/ams/97Annual/webprogram/Paper311904.html>)

Benjamin, S.G., S. S. Weygandt, J. M. Brown, M. Hu, C. Alexander, T. G. Smirnova, J. B. Olson, E. James, D. C. Dowell, G. A. Grell, H. Lin, S. E. Peckham, T. L. Smith, W. R. Moninger, J. Kenyon, and G. S. Manikin, 2016: A North American Hourly Assimilation and Model Forecast Cycle: The Rapid Refresh. *Mon Wea Rev*, 144, 4, 1669-1694, DOI: <http://dx.doi.org/10.1175/MWR-D-15-0242.1>

Blake, B., J. R. Carley, T. Alcott, I. Jankov, M. Pyle, and A. J. Clark, 2017: Evaluation of Several Spatial Filtering Methods for Probabilistic CPM Ensemble Forecasts. 28th Conference on Weather Analysis and Forecasting/ 24th Conf. on Numerical Weather Prediction, Seattle, WA, Amer. Meteor. Soc. 1191. (Available at: <https://ams.confex.com/ams/97Annual/webprogram/Paper313250.html>)

Govett, M, J. Rosinski, J. Middlecoff, T. Henderson, J. Lee, A. MacDonald, P. Madden, J. Schramm, and A. Duarte, 2016: Parallelization and Performance of the NIM Weather Model for CPU, GPU and MIC Processors. *Bull. Amer. Meteor. Soc.*, 98, accepted.

Harrold, M., J. Henderson, C. Holt, J. Wolff, L. Bernardet, H. Jiang, and L. Nance, 2017: Evaluation of the Grell-Freitas convective scheme within the NOAA Environmental Modeling System (NEMS)-based Global Spectral Model (GSM). 28th Conference on Weather Analysis and Forecasting/ 24th Conf. on Numerical Weather Prediction, Seattle, WA, Amer. Meteor. Soc. 602. (Available online at <https://ams.confex.com/ams/97Annual/webprogram/Paper312575.html>)

Hu, M., J. Beck, S. S. Weygandt, D. C. Dowell, S. G. Benjamin, and C. Alexander 2017: Advanced Tests of GSI Hybrid 4-D and 3-D Ensemble-Variational Data Assimilation for Rapid Refresh. 21st Conference on Integrated Observing and Assimilation Systems for the Atmosphere, Oceans, and Land Surface, Seattle, WA, Amer. Meteor. Soc. 8.2. (Recorded Presentation available at: <https://ams.confex.com/ams/97Annual/webprogram/Paper313322.html>)

Jankov, I., J. Berner, J. Beck, H. Jiang, J. Olson, G. Grell, T. Smirnova, S. Benjamin, and J. Brown, 2017: A Performance Comparison between Multiphysics and Stochastic Approaches within a North American RAP Ensemble. *Mon. Wea. Rev.*, DOI: <http://dx.doi.org/10.1175/MWR-D-16-0160.1> ,in press.

Jiang, H., G. Grell, L. Bernardet, J. Henderson, M. Harrold, C. Holt, J. Wolff, L. Carson, J-W. Bao, and J. Brown 2017: Implementation and analyzing the Grell-Freitas Convective Parameterization in The NOAA Environmental Modeling System-Based Global Spectral Model. 28th Conference on Weather Analysis and Forecasting/ 24th Conf. on Numerical Weather Prediction, Seattle, WA, Amer. Meteor. Soc. 603. (Available online at: <https://ams.confex.com/ams/97Annual/webprogram/Paper312589.html>)

Lin, H., S. S. Weygandt, S. G. Benjamin, and M. Hu, 2017: Satellite radiance data assimilation within the hourly updated Rapid Refresh. *Wea. Forecasting*, 32, accepted.

Lin, H., S. S. Weygandt, A. H. N. Lim, M. Hu, J. M. Brown, S. G. Benjamin, 2017: AIRS radiance assimilation within the Rapid Refresh mesoscale model system. *Wea. Forecasting*, submitted.

Lin, H., S. S. Weygandt, Y. Xie, M. Hu, S. G. Benjamin, 2017: Satellite radiance assimilation enhancements for RAP version 4. Fifth AMS Symposium on the Joint Center for Satellite Data Assimilation (JCSDA), Seattle, WA, Amer. Met. Soc., 2.3. (Recorded Presentation available at: <https://ams.confex.com/ams/97Annual/webprogram/Paper313314.html>)

Shao, H., C. Zhou, M. Hu, K. M. Newman, and J. Beck, 2017: 4D EnVar Data Assimilation for the High Resolution Rapid Refresh (HRRR) System. 21st Conference on Integrated Observing and Assimilation Systems for the Atmosphere, Oceans, and Land Surface, Seattle, WA, Amer. Meteor. Soc. 8.4. (Recorded Presentation available at: <https://ams.confex.com/ams/97Annual/webprogram/Paper312697.html>)

Smith, T. L., S. S. Weygandt, C. R. Alexander, M. Hu, H. Lin and J. R. Mecikalski, 2016: Use of convective initiation information derived from GOES satellite data in the High-Resolution Rapid Refresh (HRRR) forecast system. 28th Conference on Severe Local Storms, Portland, OR, Amer. Meteor. Soc., 98. (Available online at: <https://ams.confex.com/ams/28SLS/webprogram/Paper300816.html>)

Wolff, J., I. Jankov, J. Beck, L. Carson, J. Frimel, M. Harrold, and H. Jiang, 2016: Addressing model uncertainty through stochastic parameter perturbations within the High Resolution Rapid Refresh (HRRR) ensemble. San Francisco, CA, Amer. Geophys. Union, IN33A-1801. (Available at: <https://agu.confex.com/agu/fm16/meetingapp.cgi/Home/0>)

DATA ASSIMILATION

Research to develop and improve techniques to assimilate environmental observations, including satellite, terrestrial, oceanic, and biological observations, to produce the best estimate of the environmental state at the time of the observations for use in analysis, modeling, and prediction activities associated with weather/climate predictions (minutes to months) and analysis.

PROJECT: ENVIRONMENTAL APPLICATIONS RESEARCH

FISCAL YEAR FUNDING (EAR Total): \$7,309,853

PROJECT TITLE: EAR - Evaluation of Chemical Data Assimilation Systems for PM2.5 Observations Using WRF-Chem and CMAQ

PRINCIPAL INVESTIGATOR: Sher Schranz

RESEARCH TEAM: Ka Yee Wong

NOAA TECHNICAL CONTACT: Georg Grell (OAR/ESRL/GSD/MDB Chief)

NOAA RESEARCH TEAM: Mariusz Pagowski (CIRES)

PROJECT OBJECTIVES:

Evaluate aerosol data assimilation methods for air quality forecasting.

PROJECT ACCOMPLISHMENTS:

Continued to perform evaluations of the assimilation procedure used in real-time forecasting with RAP-Chem. Maintained real-time WRF-Chem and RAP-Chem runs on NOAA's high performance computing systems (Zeus and Theia).

Continued to support RAP-Chem transition to operations at NCEP.

PROJECT TITLE: EAR - Local Analysis and Prediction System (LAPS)

PRINCIPAL INVESTIGATOR: Sher Schranz

RESEARCH TEAM: Steve Albers, Hongli Jiang

NOAA TECHNICAL CONTACT: Stan Benjamin (OAR/ESRL/GSD/ADB Chief)

NOAA RESEARCH TEAM: Yuanfu Xie (OAR/ESRL/GSD/ADB)

PROJECT OBJECTIVES:

Improvement and enhancement of the LAPS in providing real-time, three-dimensional, local-scale analyses and short-range forecasts for domestic and international operational weather offices, academia, private sector, aviation and other field operations.

PROJECT ACCOMPLISHMENTS:

All versions of the LAPS are no longer part of the research program at GSD. All investigations related to LAPS processes are now conducted using the HRRR model and GSI data assimilation systems.

PROJECT TITLE: EAR - Data Assimilation for the High Resolution Rapid Refresh (HRRR) System

PRINCIPAL INVESTIGATOR: Sher Schranz

RESEARCH TEAM: Steve Albers

NOAA TECHNICAL CONTACT: Stan Benjamin (OAR/ESRL/GSD/ADB Chief)

NOAA RESEARCH TEAM: Yuanfu Xie (OAR/ESRL/GSD/ADB), Trevor Alcott (OAR/ESRL/GSD/MDB), Steve Weygandt (OAR/ESRL/GSD/ADB), Ming Hu (CIRES)

PROJECT OBJECTIVES:

- 1--Inclusion of radar data in the GSI supporting the HRRR Alaska domain GSI;
- 2--Assimilation of all-sky cameras.

PROJECT ACCOMPLISHMENTS

- 1--Test HRRR-Alaska and evaluate and add radar. Develop proficiency in running HRRR (including GSI and ARW).

Goals:

- Complete running a HRRR-AK retro including GSI and HRRR and post-processing for a case. (Coordination with Steve Weygandt and Trevor Alcott).
- Successfully added MRMS Alaska radar data to HRRR-AK test.
- Demonstrated successful difference in reflectivity at 0h and 1h and with and without the Alaska reflectivity data.

Preliminary runs: After doing a practice run on HRRR-CONUS domain, scripts were set up (developed by Trevor Alcott) with associated data for two HRRR-AK runs, one without Alaska radar data and one with. I have performed the retro run of the "no-radar" case. The WRF and Unipost steps ran to completion. I made various script modifications needed to get the NCL graphics generation to work on THEIA for Alaska, and the plots now show up though so far without map backgrounds (Brian Jamison looked at this

and it appears that the map projection parameters in the GRIB files produced by the UPP are off). In Figure 1 we can see 00hr and 01hr radar reflectivity forecasts.

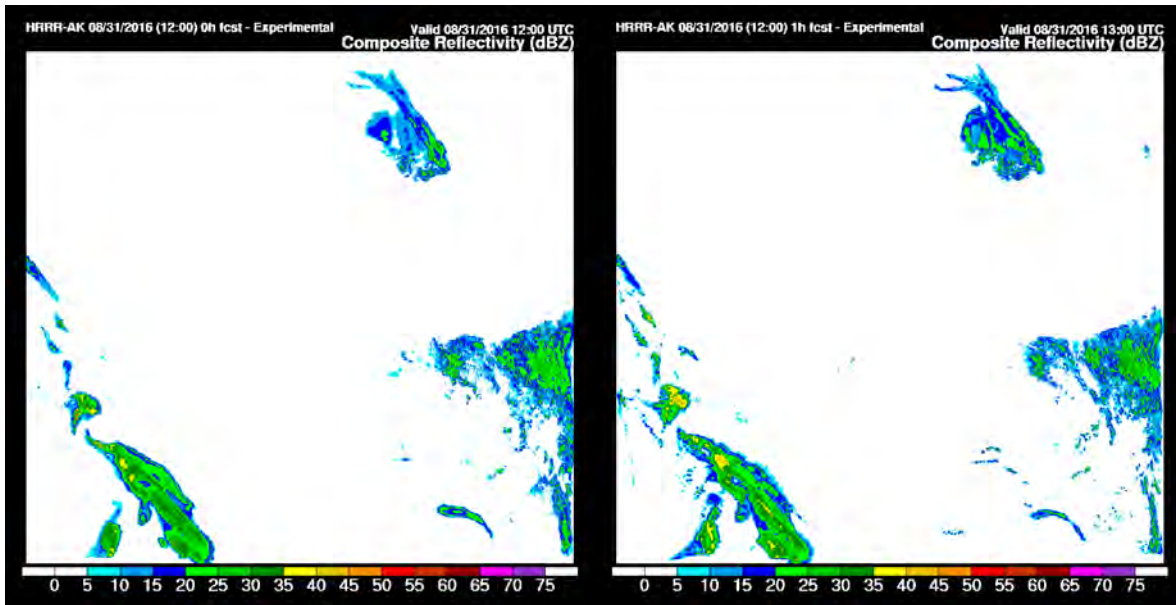

Figure 1. 00hr and 01hr radar reflectivity forecasts.

Status:

--Updating several data gathering scripts and testing their use on a new case for November 10 that combines the standard observations, RAP grids (with a new interpolation step for the Alaska map projection), and NSSL MRMS Alaska radar data, now available here at the DSRC.

--The non-radar run OK though for a while the 'wrf_arw_pre' task had been crashing. A variety of tests led to the conclusion that the WRF was having CFL violations due to the steep terrain. Use of a new smoothed terrain static file now allows the WRF to run. Below are the 00,01hr radar reflectivity forecasts.

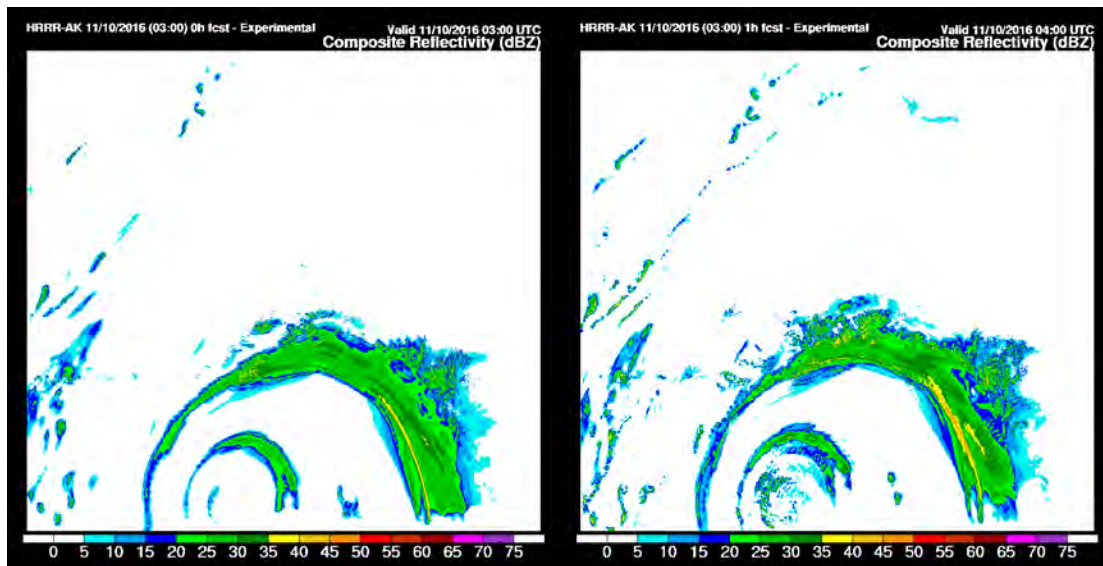

Figure 2. 00,01hr radar reflectivity forecasts.

--The "with-radar" run is being tested and the initial processing of the MRMS grib data was successful after some script modifications for the file conventions of the new data source, and other software changes. There are changes both at 00 and 01 hours within the main rainband of this Gulf of Alaska storm. The reflectivity is strong enough in small areas to trigger the diabatic heating.

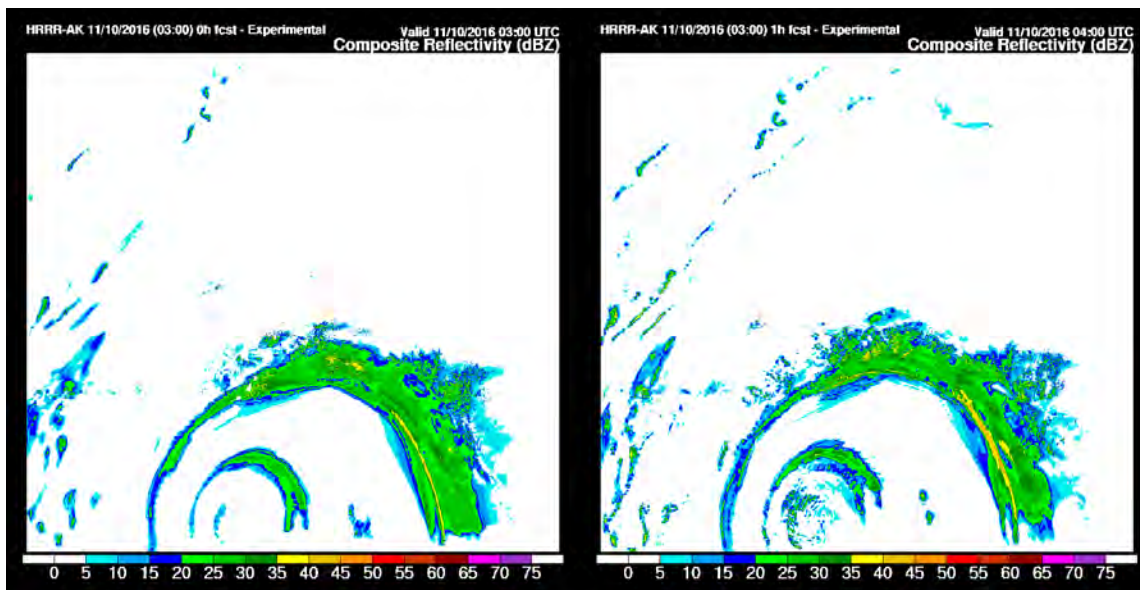

Figure 3.

Future Work:

--Based on feedback from forecasters in Alaska, case reruns from additional times are planned to evaluate the benefit of adding radar data into the analysis.

2--Enhance GSI by adding forward model for all-sky camera data to the GSI cloud analysis. Demonstrate hydrometeor change fields. (Collaborate with Ming Hu, Steve Weygandt, and Yuanfu Xie).

Goals:

--GSI modification for all-sky camera data added to other data (satellite, METAR) in GSI cloud analysis.
--Demonstration of successful GSI test with all-sky camera data.

Status: The original all-sky code was developed using the PGI compiler. We have now set this up in a portable stand-alone interface that will be easily linkable to GSI. After some code cleanup this has been run-time tested with the Intel compiler (used by GSI) yielding acceptable image comparison results between PGI and Intel. The simulation software returns the cloud optical thickness along the line of sight that will be thresholded into binary (yes/no) cloud values.

We are presently testing the interface and all-sky routines within the GSI executable program. Runtime testing can be benchmarked on a single processor using a coarse alt-azimuth grid, using a small domain or sub-domain. We can later see about needs and options for parallelization. We can also test a couple of different ray marching strategies that are presently in the software. One method picks a uniform step size chosen based on horizontal and (approximate) vertical grid spacing along with elevation angle of the particular ray, thus minimizing aliasing effects. Another method steps between successive cube faces on the 3-D grid, slightly slower and more rigorous. A terrain following model grid option has been added to the ray tracing routine that will work with cloud mask processing. For radiance images a prior interpolation to a more slowly varying constant pressure grid will still be needed. The present GSI code can produce simulated sky images as in this clear sky example:

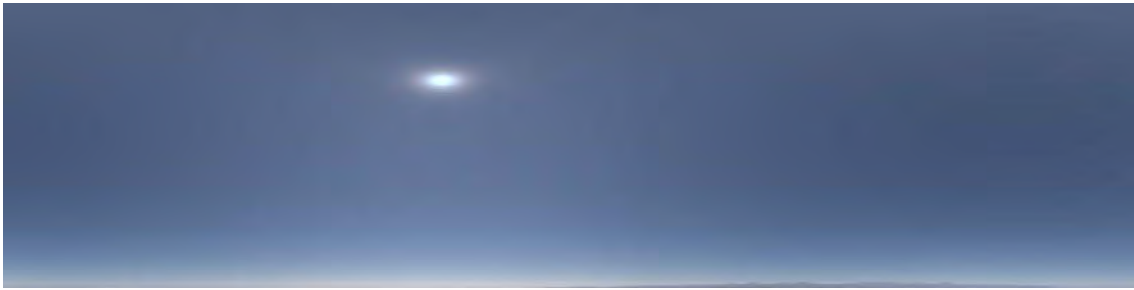

Figure 4. Simulated clear sky

We are concurrently working to use the DSRC “Moonglow” all-sky camera for assimilation. A FORTRAN subroutine has been written that reads the processed hemispherical camera images in the form of a yes/no/unknown cloud mask. These flags were previously encoded from the original camera images using separate IDL procedures. The subroutine then remaps them to the alt-azimuth grid.

I’ve been using a version of Yuanfu’s Xie’s GSI linked allsky simulator code copied into this directory - ‘theia:/scratch3/BMC/wrfruc/albers/emb/allsky/gsi’. With this code I’ve made some GSI modifications to call the camera reading subroutine. The strategy is to write in the log file some information pertaining to a comparison of the observed and simulated “yes/no” clouds along the camera lines of sight. The camera categorical cloud mask has been read into the GSI and an ASCII “picture” of this mask is shown in the log file. The camera data are also reformatted in the GSI ‘read_obs’ set of routines and written to disk using a standard format shared by all the obs types for further use in the analysis.

The algorithm producing the cloud mask derived from the camera images is presently being refined based on visual comparison between camera image and mask. The mask is produced mainly by examining image color ratios. Additional quality control checks can be considered and various thresholds can be adjusted to help prevent false cloud detections by the camera. Beyond this, simulated clear sky radiances compared with camera image intensity could help refine the mask by filtering out areas with large amounts of aerosol scattering or with camera lens glare. The figure below compares an all-sky camera image (left) to a cloud mask (right) at 2115 UTC Oct 24, 2016. White represents clouds in the mask while blue is clear and green is unknown.

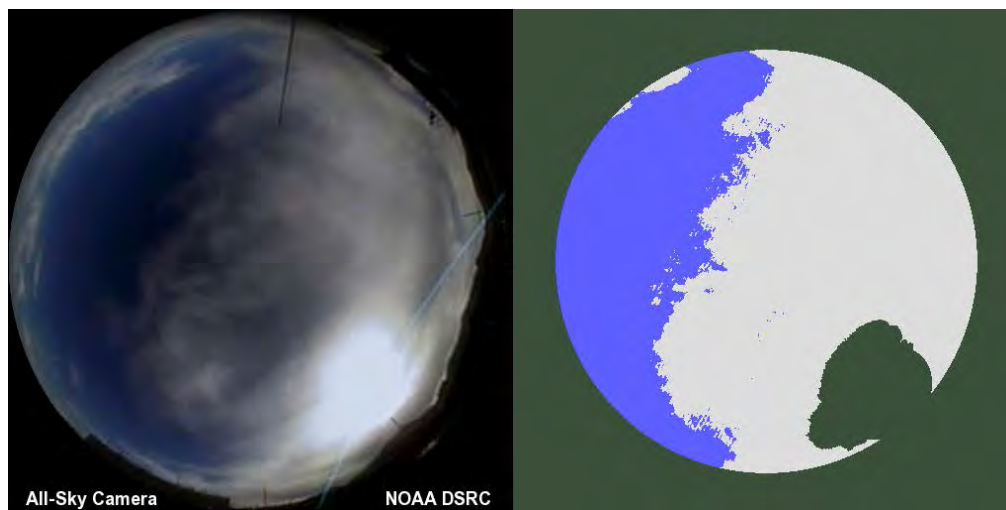

Figure 5. Comparison of an all-sky camera image (left) to a cloud mask (right) at 2115 UTC Oct 24, 2016

Future Work: We will start the actual assimilation experiments by using the camera cloud mask in a cloud clearing mode. Looking ahead to allowing the addition of clouds, one question is whether the GSI variational solver can converge on where along the line of sight a particular cloud is to be added. Can background error covariances be used to help constrain the clouds spatially, and to other model fields that are in turn influenced by the first guess and other data sources (such as METARs and satellite - in a simultaneous analysis)? Should the strategy be coordinated with what is done in the HRRR with cloud top pressure (or future satellite “all-sky” radiance) insertion? Other variational cost function constraints can be considered based on perturbations in the Qv, RH and T fields, as done in a 1DVAR sense when adding satellite clouds in LAPS. Thus the all-sky camera or satellite can tell us about the presence and integrated amount of clouds while the other model fields help to place the clouds along the line of sight. We’re presently testing with a single camera, though we might envision a network of cameras to help constrain the analysis. We might compare notes with GSD’s Radio Occultation (RO) group about their handling of fields that vary along a slant path.

An interesting seminar on variational analysis (tomography) of camera images and other solar radiation measurements can be found online, in this case using SHDOM for 3-D radiative transfer:

http://www.robots.ox.ac.uk/~seminars/seminars/Extra/2015_09_17_AviadLevis.pdf

It is interesting to compare the techniques that could be used with forward modeling sky & land radiance, along with edge detection algorithms (from LL and NCAR) to determine visibility. It is possible that each method could complement the other and a combination of both methods may be useful as well. For example, the allsky-software returns distance to the terrain along each line of sight that can help in identifying landmarks and their distances in the Alaska camera images. Another thought is that simulated cases of various cloud ceilings can be rendered to see how they lie along the terrain, thus helping with camera image interpretation of cloud ceilings. The simulated imagery can also help with assessing changes in sky and land illumination due to sun angle and clouds that can have an impact on the camera image contrast and edge detections. In the long run a combination of broad-scale radiance and fine scale edges in the camera images can be used in a full variational solution of clouds and visibility obstructions in 3-dimensions.

Additional activities with the all-sky cameras could include validation of analysis and forecast output, through a comparison of simulated and actual images. The simulated images can also be used in NWS offices and elsewhere to provide visual displays of model output.

EAR Publications:

Alcott, T., I. Jankov, C. Alexander, S. Weygandt, S. Benjamin, J. Carley, and B. T. Blake, 2017: Calibrated, probabilistic hazard forecasts from a Time-Lagged Ensemble. 33rd Conf. on Environmental Information Processing Technologies, Seattle, WA, Amer. Meteor. Soc. (Recorded Presentation available at: <https://ams.confex.com/ams/97Annual/webprogram/Paper311242.html>)

Alcott, T., C. Alexander, S. Albers, R. Ahmadov, E. James, S. Benjamin, and S. Weygandt, 2017: HRRR-AK: A High-Resolution, Rapidly Cycled Forecast Model for Alaska. 28th Conference on Weather Analysis and Forecasting/ 24th Conf. on Numerical Weather Prediction, Seattle, WA, Amer. Meteor. Soc. 615. (Available online at: <https://ams.confex.com/ams/97Annual/webprogram/Paper306923.html>)

Alexander, C., T. Alcott, I. Jankov, S. Weygandt, and S. G. Benjamin, 2017: Ensemble Prediction with the High-Resolution Rapid refresh (HRRR): Providing Probabilistic Forecasts of Weather Hazards for Aviation. 18th Conference on Aviation, Range, and Aerospace Meteorology, Seattle, WA, Amer. Meteor. Soc. (Recorded Presentation available at: <https://ams.confex.com/ams/97Annual/webprogram/Paper313352.html>)

Beck, J., I. Jankov, H. Jiang, J.K. Wolff, M. Harrold, J. Frimel, and L. Carson, 2017: An Evaluation of Stochastic Physics Within the High Resolution Rapid Refresh (HRRR) Ensemble and the Impacts of High Performance Computing (HPC). 3rd Symposium on High Performance Computing for Weather, Water and Climate, Seattle, WA, Amer. Meteor. Soc., 1441. (Available at: <https://ams.confex.com/ams/97Annual/webprogram/Paper311904.html>)

Benjamin, S.G., S. S. Weygandt, J. M. Brown, M. Hu, C. Alexander, T. G. Smirnova, J. B. Olson, E. James, D. C. Dowell, G. A. Grell, H. Lin, S. E. Peckham, T. L. Smith, W. R. Moninger, J. Kenyon, and G. S. Manikin, 2016: A North American Hourly Assimilation and Model Forecast Cycle: The Rapid Refresh. *Mon Wea Rev*, 144, 4, 1669-1694, DOI: <http://dx.doi.org/10.1175/MWR-D-15-0242.1>

Blake, B., J. R. Carley, T. Alcott, I. Jankov, M. Pyle, and A. J. Clark, 2017: Evaluation of Several Spatial Filtering Methods for Probabilistic CPM Ensemble Forecasts. 28th Conference on Weather Analysis and Forecasting/ 24th Conf. on Numerical Weather Prediction, Seattle, WA, Amer. Meteor. Soc. 1191. (Available at: <https://ams.confex.com/ams/97Annual/webprogram/Paper313250.html>)

Govett, M, J. Rosinski, J. Middlecoff, T. Henderson, J. Lee, A. MacDonald, P. Madden, J. Schramm, and A. Duarte, 2016: Parallelization and Performance of the NIM Weather Model for CPU, GPU and MIC Processors. *Bull. Amer. Meteor. Soc.*, 98, accepted.

Harrold, M., J. Henderson, C. Holt, J. Wolff, L. Bernardet, H. Jiang, and L. Nance, 2017: Evaluation of the Grell-Freitas convective scheme within the NOAA Environmental Modeling System (NEMS)-based Global Spectral Model (GSM). 28th Conference on Weather Analysis and Forecasting/ 24th Conf. on Numerical Weather Prediction, Seattle, WA, Amer. Meteor. Soc. 602. (Available online at <https://ams.confex.com/ams/97Annual/webprogram/Paper312575.html>)

Hu, M., J. Beck, S. S. Weygandt, D. C. Dowell, S. G. Benjamin, and C. Alexander 2017: Advanced Tests of GSI Hybrid 4-D and 3-D Ensemble-Variational Data Assimilation for Rapid Refresh. 21st Conference on Integrated Observing and Assimilation Systems for the Atmosphere, Oceans, and Land Surface, Seattle, WA, Amer. Meteor. Soc. 8.2. (Recorded Presentation available at: <https://ams.confex.com/ams/97Annual/webprogram/Paper313322.html>)

Jankov, I., J. Berner, J. Beck, H. Jiang, J. Olson, G. Grell, T. Smirnova, S. Benjamin, and J. Brown, 2017: A Performance Comparison between Multiphysics and Stochastic Approaches within a North American RAP Ensemble. *Mon. Wea. Rev.*, DOI: <http://dx.doi.org/10.1175/MWR-D-16-0160.1> ,in press.

Jiang, H., G. Grell, L. Bernardet, J. Henderson, M. Harrold, C. Holt, J. Wolff, L. Carson, J-W. Bao, and J. Brown 2017: Implementation and analyzing the Grell-Freitas Convective Parameterization in The NOAA Environmental Modeling System-Based Global Spectral Model. 28th Conference on Weather Analysis and Forecasting/ 24th Conf. on Numerical Weather Prediction, Seattle, WA, Amer. Meteor. Soc. 603. (Available online at: <https://ams.confex.com/ams/97Annual/webprogram/Paper312589.html>)

Lin, H., S. S. Weygandt, S. G. Benjamin, and M. Hu, 2017: Satellite radiance data assimilation within the hourly updated Rapid Refresh. *Wea. Forecasting*, 32, accepted.

Lin, H., S. S. Weygandt, A. H. N. Lim, M. Hu, J. M. Brown, S. G. Benjamin, 2017: AIRS radiance assimilation within the Rapid Refresh mesoscale model system. *Wea. Forecasting*, submitted.

Lin, H., S. S. Weygandt, Y. Xie, M. Hu, S. G. Benjamin, 2017: Satellite radiance assimilation enhancements for RAP version 4. Fifth AMS Symposium on the Joint Center for Satellite Data Assimilation (JCSDA), Seattle, WA, Amer. Met. Soc., 2.3. (Recorded Presentation available at: <https://ams.confex.com/ams/97Annual/webprogram/Paper313314.html>)

Shao, H., C. Zhou, M. Hu, K. M. Newman, and J. Beck, 2017: 4D EnVar Data Assimilation for the High Resolution Rapid Refresh (HRRR) System. 21st Conference on Integrated Observing and Assimilation Systems for the Atmosphere, Oceans, and Land Surface, Seattle, WA, Amer. Meteor. Soc. 8.4. (Recorded Presentation available at: <https://ams.confex.com/ams/97Annual/webprogram/Paper312697.html>)

Smith, T. L., S. S. Weygandt, C. R. Alexander, M. Hu, H. Lin and J. R. Mecikalski, 2016: Use of convective initiation information derived from GOES satellite data in the High-Resolution Rapid Refresh (HRRR) forecast system. 28th Conference on Severe Local Storms, Portland, OR, Amer. Meteor. Soc., 98. (Available online at: <https://ams.confex.com/ams/28SLS/webprogram/Paper300816.html>)

Wolff, J., I. Jankov, J. Beck, L. Carson, J. Frimel, M. Harrold, and H. Jiang, 2016: Addressing model uncertainty through stochastic parameter perturbations within the High Resolution Rapid Refresh (HRRR) ensemble. San Francisco, CA, Amer. Geophys. Union, IN33A-1801. (Available at: <https://agu.confex.com/agu/fm16/meetingapp.cgi/Home/0>)

PROJECT TITLE: Hydrometeorological and Water Resources Research

PRINCIPAL INVESTIGATOR: V. Chandrasekar

RESEARCH TEAM: Haonan Chen, Jungho Kim

NOAA TECHNICAL CONTACT: Robert Cifelli, Physical Sciences Division, NOAA/Earth System Research Laboratory

NOAA RESEARCH TEAM: Robert Cifelli, Physical Sciences Division, NOAA/Earth System Research Lab

FISCAL YEAR FUNDING: \$179,844

PROJECT OBJECTIVES:

- 1--Deployment of scanning X-band radar in Santa Clara Valley in support of NOAA El Niño Rapid Response (ENRR) field campaign
- 2--Evaluation of Quantitative Precipitation Estimation and Forecast (QPE/QPF) in the San Francisco Bay Area
- 3--Improving NOAA CMORPH with ground-based radar observations
- 4--Demonstration of the interoperability between NOAA distributed hydrologic model (DHM) and USGS wave-hydrodynamic model (CoSMoS) in the San Francisco Bay Area

PROJECT ACCOMPLISHMENTS:

Project 1--Deployment of scanning X-band radar in Santa Clara Valley in support of NOAA El Niño Rapid Response (ENRR) field campaign

In response to the El Niño conditions, a dual-polarization X-band (wavelength ~3cm) radar was deployed to the Santa Clara Valley (i.e., XSCV radar) to augment NEXRAD coverage and aid in monitoring precipitation for local forecasters and water managers as well as to better understand precipitation processes occurring in this region. The system was also used to provide high quality precipitation estimation for Santa Clara's hydrologic modeling system for monitoring and predicting urban runoff. This project provided high quality rainfall estimates at high resolution compared to NEXRAD, with 90s

temporal and 250m spatial resolution. The accuracy of the X-band rainfall estimates was demonstrated using rain gauge network operated by the Valley Water District, which showed superior performance to NEXRAD-based products, especially at the high end rain rates which are important for accurate prediction of flooding.

Project 2--Evaluation of Quantitative Precipitation Estimation and Forecast (QPE/QPF) in the San Francisco Bay Area

A continental-scale hourly updated assimilation and model forecast system, termed "Rapid Refresh" or "RAP" in short, was developed in NOAA, in order to produce operational precipitation forecasts. Nowadays, the RAP system is one of the mainstream models running operationally in National Centers for Environmental Prediction (NCEP). As a complement of RAP, the 3km High-Resolution Rapid Refresh (HRRR) system is also updated hourly, but covering a smaller geographic domain. The HRRR system is primarily comprised of a numerical forecast model and an assimilation system to initialize that model. This project conducts a detailed comparison between precipitation forecasts from the HRRR model and various radar-based precipitation estimates, including the operational rainfall products from NSSL's Multi-Radar/Multi-Sensor (MRMS) system. The performance of various quantitative precipitation estimation and forecast products is evaluated using rainfall measurements from an independent gauge network. The performance of HRRR model-based precipitation forecasts as a function of forecast lead time is investigated, which is important for issuing flood watches and warnings as well as for a variety of water management activities in the San Francisco Bay area.

Project 3--Improving NOAA CMORPH with ground-based radar observations

A number of precipitation products at multiple space time scales have been developed based upon satellite observations, such as the NOAA Climate Prediction Center morphing technique (i.e., CMORPH) based products which are derived by combining existing space based rainfall estimates. Although the space-based precipitation products provide an excellent tool for regional and global hydrologic and climate studies as well as improved situational awareness for operational forecasts, its accuracy is restricted due to the limitations of spatial-temporal sampling and the parametric retrieval algorithms, particularly for extreme events such as very light and/or heavy rain. On the other hand, ground-based radar is more mature science for quantitative precipitation estimation (QPE), especially after the implementation of dual-polarization technique and further enhanced by urban scale radar networks. Therefore, ground radars are often critical for providing local scale rainfall estimation and a "heads-up" for operational forecasters to issue watches and warnings as well as validation of various space measurements and products. This project explores the potential of dual-polarization radar observations for evaluating and improving CMORPH products. A neural network based fusion system, termed Multi-Layer Perceptron (MLP), has been proposed to enhance CMORPH using operational S-band radar network as well as research X-band radar networks. Particularly, the CMORPH methodology is first applied to derive combined microwave (MW) rainfall estimates and combined infrared (IR) data from multiple satellites. The combined MW and IR data then serve as input of the proposed MLP model. The high-quality ground radar based rainfall products are used to train the model. The MLP model-based rainfall products are evaluated using existing CMORPH products and surface rainfall measurements from gauge networks.

Project 4--Demonstration of the interoperability between NOAA distributed hydrologic model (DHM) and USGS wave-hydrodynamic model (CoSMoS) in the San Francisco Bay Area

- Demonstrated the capability of using selected NWS precipitation grids to force DHM
- Demonstrated the capability of using NWS forecast model output to force CoSMoS
- The connectivity between CoSMoS and DHM has been established
- The impacts of storm flooding have been assessed



Figure 1. (a) Location and coverage map of X-band dual-polarization XSCV radar in Santa Clara, CA; (b) a photo of the XSCV radar during the deployment. The coverage range is 40km. The red dots in (a) denote the locations of rainfall gauges operated by SCVWD. The blue square in (a) illustrates the location of S-band KMUX NEXRAD radar. (for Project 1)

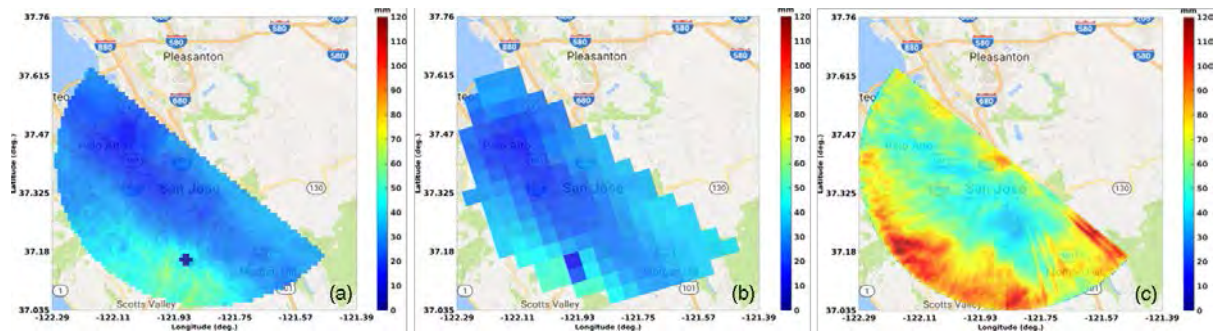

Figure 2. 13-hr rainfall accumulations from 00:00-13:00UTC, March 06, 2016: (a) MRMS radar only; (b) MPE radar only; (c) XSCV radar. (for Project 1)

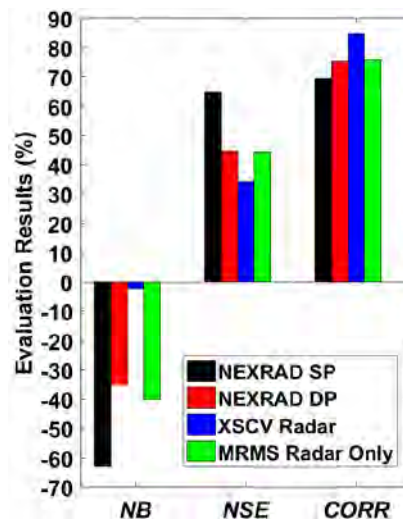

Figure 3. Evaluation results of hourly rainfall estimates from 01:00-13:00UTC, March 06, 2016, including normalized bias (*NB*), normalized standard error (*NSE*), and correlation coefficient (*CORR*). The data are based on radar and gauge rainfall observations at 30 gauge locations under the XSCV radar coverage (see Figure 1). (for Project 1)

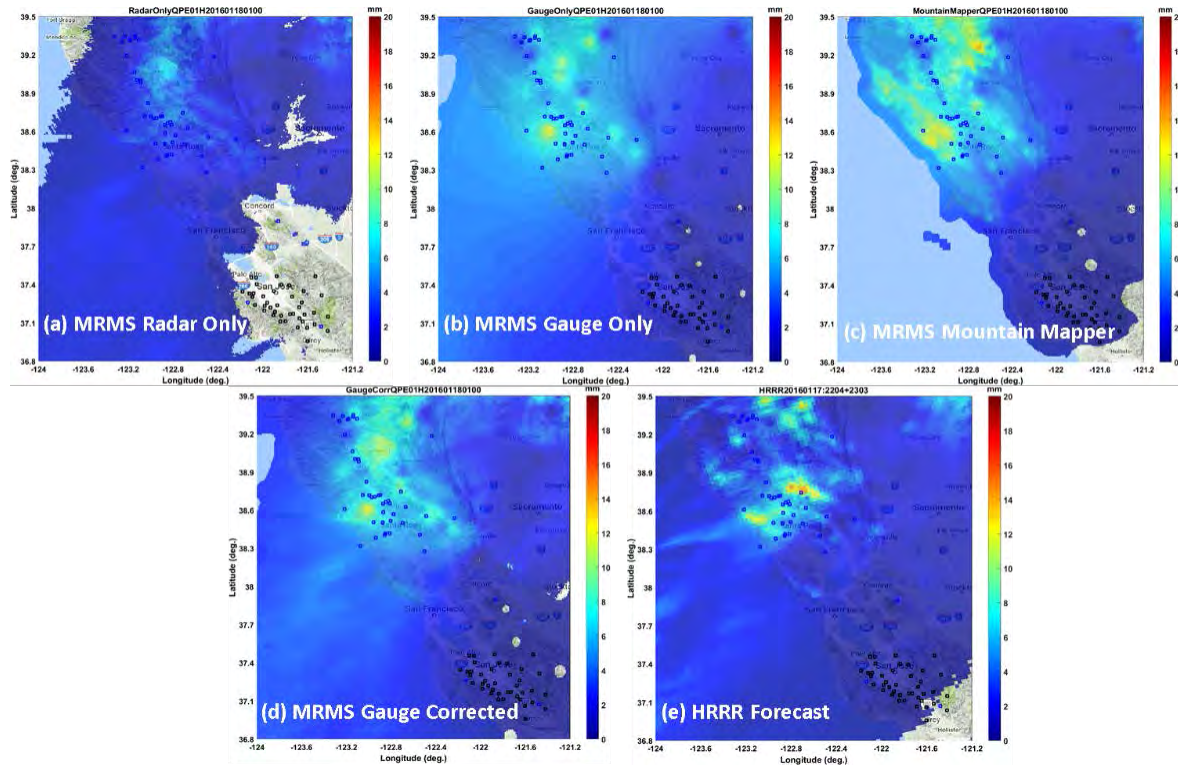

Figure 4. Hourly rainfall estimates (forecasts) from MRMS (HRRR) on 18 Jan 2016, 01-02 UTC. (for Project 2)

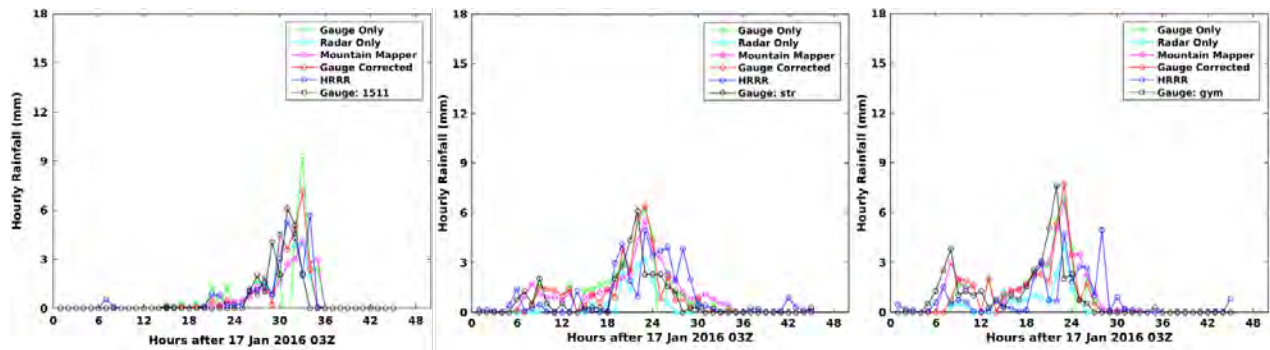

Figure 5. Time series of hourly rainfall estimates (forecasts) from MRMS (HRRR) at sample gauge locations (denoted by gauge id's in the figure) on 17 Jan 2016, where "Gauge Only", "Radar Only", "Mountain Mapper", and "Gauge Corrected" are from MRMS. (for Project 2)

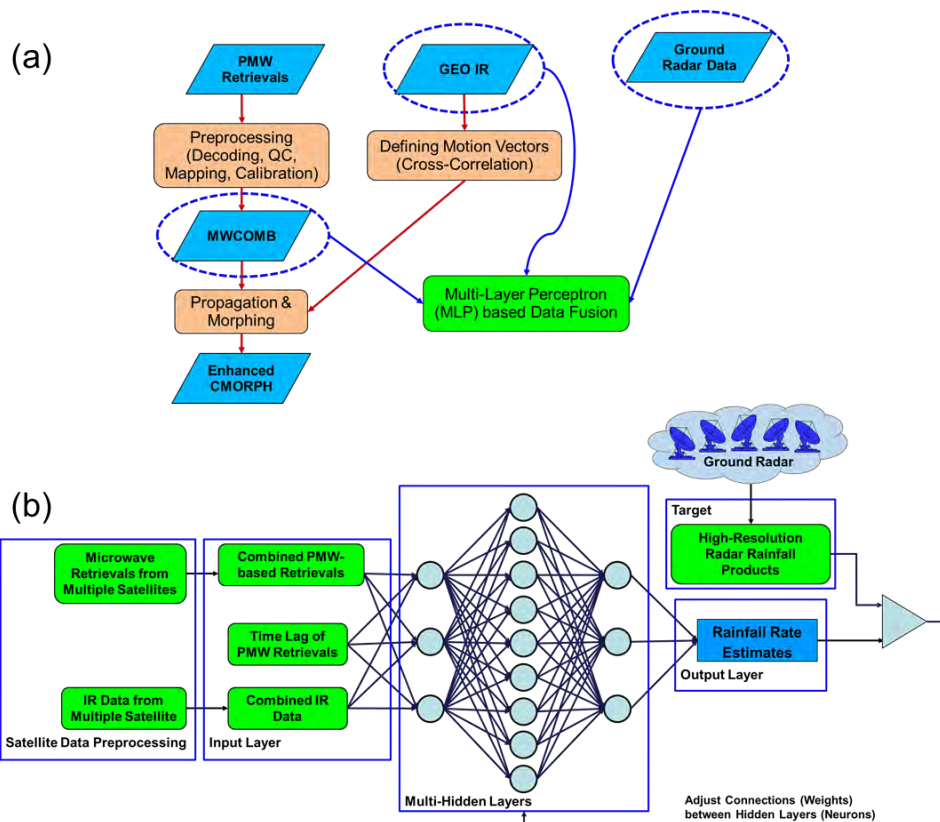

Figure 6. (a) Conceptual diagram illustrating ground radar and satellite data fusion; (b) proposed Multi-Layer Perceptron framework for precipitation data fusion. (for Project 3)

Publications:

Chen, Haonan, V. Chandrasekar, H. Tan, R. Cifelli, and P. Xie, 2016: Development of Deep Learning Based Data Fusion Approach for Accurate Rainfall Estimation Using Ground Radar and Satellite Precipitation Products. American Geophysical Union Fall Meeting, San Francisco, California.

Cifelli, R., Haonan Chen, and V. Chandrasekar, 2016: Rainfall Estimation and Performance Characterization Using a X-band Dual-Polarization Radar in the San Francisco Bay Area. American Geophysical Union Fall Meeting, San Francisco, California.

Cifelli, R., V. Chandrasekar, Haonan Chen, and L. E. Johnson, 2017: High Resolution Radar Quantitative Precipitation Estimation in the San Francisco Bay Area: Rainfall Monitoring for the Urban Environment. Journal of the Meteorological Society of Japan. (under review)

Cifelli, R., Haonan Chen, and V. Chandrasekar, 2017: Comparison of Precipitation Forecasts from NOAA's High Resolution Rapid Refresh (HRRR) Model with Polarimetric Radar Observations in the San Francisco Bay Area. IEEE International Geoscience and Remote Sensing Symposium, Fort Worth, Texas.

Herdman, L., L. Erickson, P. Barnard, J. Kim, R. Cifelli, and L. Johnson, 2016: Integrating Fluvial and Oceanic Drivers in Operational Flooding Forecasts for San Francisco Bay. The European Geosciences Union (EGU) General Assembly, Vienna, Austria

Herdman, L., J. Kim, R. Cifelli, P. Barnard, L. Erickson, L. Johnson, and V. Chandrasekar, 2016: Coupling Fluvial and Oceanic Drivers in Flooding Forecasts for San Francisco Bay. American Geophysical Union Fall Meeting, San Francisco, California.

Kim, J., R. Cifelli, L.E. Johnson, and V. Chandrasekar, 2016: Soil Water Retention Curve (S-curve). American Geophysical Union Fall Meeting, San Francisco, California.

Kim, J., R. Cifelli, L.E. Johnson, and V. Chandrasekar, 2017: A Potential Maximum Soil Moisture Retention Curve. Hydrological Processes. (under review)

CLIMATE-WEATHER PROCESSES

Research focusing on using numerical models and environmental data, including satellite observations, to understand processes that are important to creating environmental changes on weather and short-term climate timescales (minutes to months) and the two-way interactions between weather systems and regional climate.

PROJECT TITLE: Building a “Citizen Science” Soil Moisture Monitoring System Utilizing the Community Collaborative Rain, Hail and Snow Network (CoCoRaHS)

PRINCIPAL INVESTIGATOR: Nolan Doesken, Dept. of Atmospheric Science, CSU

RESEARCH TEAM: Peter Goble, Chad McNutt, Julian Turner, Noah Newman, Henry Reges, Zach Schwalbe

NOAA TECHNICAL CONTACT: Veve Dehaza, NOAA NIDIS Program Office, Boulder, CO

NOAA RESEARCH TEAM: NA

FISCAL YEAR FUNDING: \$0

PROJECT OBJECTIVES:

Soil moisture is a key lead indicator in the development, severity and impact of drought but is not adequately monitored in most parts of the country. A new NASA satellite mission – the Soil Moisture Active Passive (SMAP) satellite has recently been launched and will be capable of sensing soil moisture near the skin surface of the earth but not in the root zone of most plants.

The objective of this project is to develop and propagate a low cost, low tech, soil moisture monitoring program utilizing the existing cyberinfrastructure and human resources of the Community Collaborative Rain, Hail and Snow network (CoCoRaHS). The goal is to provide useful information to support calibration and validation for SMAP while also producing root zone soil moisture estimates to support U.S. Drought Monitoring and early warning efforts. An equally important objective is education – demonstrating the variability and seasonality of volumetric soil moisture and how this varies geographically across the country. If this small demonstration proves successful, we hope this effort could lead to greater citizen participation in drought monitoring and timelier warnings of the onset of significant drought.

PROJECT ACCOMPLISHMENTS:

CoCoRaHS official soil moisture protocol has been developed, vetted by experts in the field, and tested by CoCoRaHS observers in the summer of 2016. Final CoCoRaHS protocol is attached below. Website infrastructure for CoCoRaHS soil moisture is now underway, and official CoCoRaHS soil moisture reports will begin in the spring of 2017.

CoCoRaHS soil moisture will be included as a part of a citizen science component to the National Soil Moisture Network, which is an effort to foster collaboration and data sharing among soil moisture data providers.

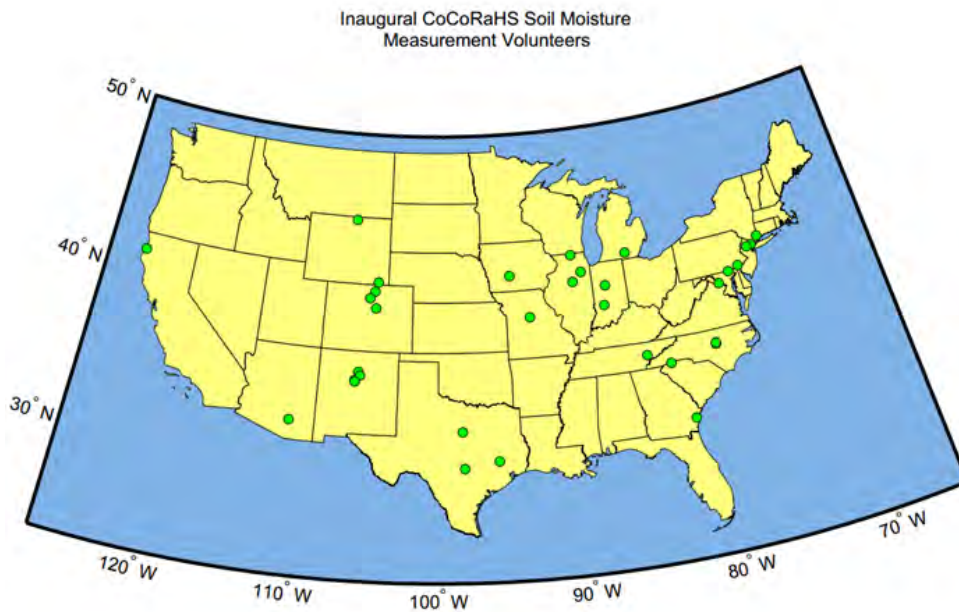

Figure 1. The map above shows the locations of the CoCoRaHS soil moisture protocol alpha test observers.

Soil Moisture Report Form			
Submit Data Reset			
Station Number : CO-LR-1107			
Station Name : Fort Collins 4.5 WNW			
* Denotes Required Field			
3/15/2017	*Observation Date ?		
7:00 AM	*Observation Time ?		
Observation Notes: (This will be available to the public) ?			
<input type="text"/>			
Information about where the sample was taken			
Distance from previous sample in meters: <input type="text"/>			
Did you begin a new row? <input type="radio"/> Yes <input type="radio"/> No			
Soil Samples			
Depth	Weight Before Drying (grams)	Volume of Rocks and Roots Removed(cm3)	Weight After Drying (grams)
0-2" ▼	<input type="text"/>	<input type="text"/>	<input type="text"/>
0-2" ▼	<input type="text"/>	<input type="text"/>	<input type="text"/>
Submit Data Reset			

Figure 2. The screen shot above shows a sample CoCoRaHS soil moisture report form.

CoCoRaHS Soil Moisture (Thank You For Your Submission!)

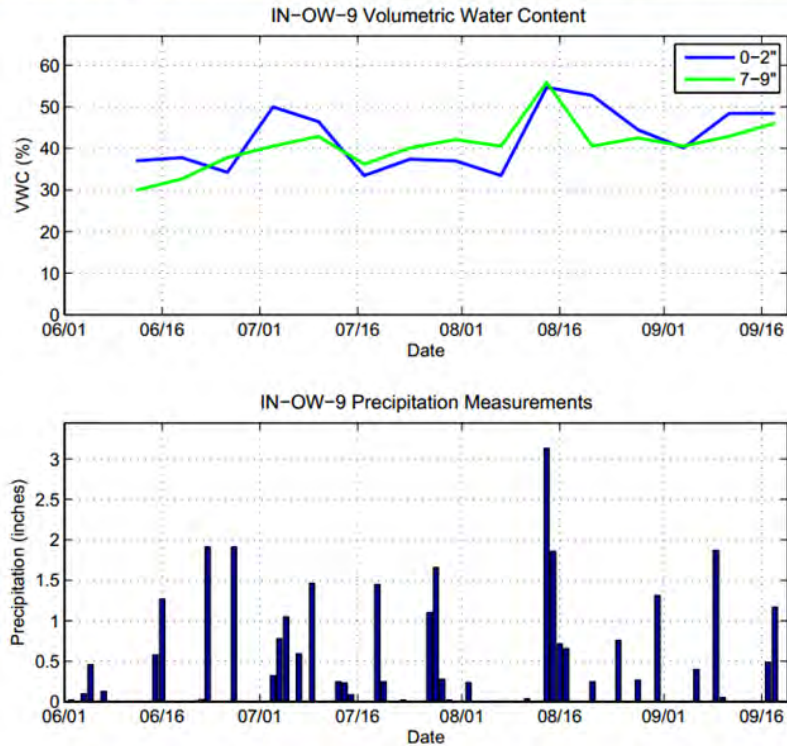

Figure 3. The plots above show CoCoRaHS soil moisture measurements at surface depth (blue), and root zone depth (green). The Bottom plot shows the same observer's day-by-day precipitation reports.

Publications

Updates on CoCoRaHS' journey to a full soil moisture launch were presented twice over the past year of this project.

Office of Science and Technology Policy Round Table Meeting, District of Columbia, March 23rd, 2016

National Soil Moisture Network Workshop, Boulder, Colorado, May 24-26

CoCoRaHS Soil Moisture Protocol:

CoCoRaHS Soil Moisture Measurement Protocol

Before beginning to measure soil moisture, estimate the dry density of your soil samples in two ways as a cross check for one another: using the web soil survey provided by the United States Department of Agriculture, and using the field soil texture test from the Colorado Master Gardener Program. The dry density obtained by your soil samples will likely be lower than your estimated dry density near the surface due to the presence of organic material. Dry densities of soils (density of solids plus air with no water in pore space) should typically range

between 1.1 and 1.6 $\frac{g}{cm^3}$. You won't be able to determine to any remarkable precision what the density of your samples when dried should be, but the main takeaway from a soil type calibration is to narrow down your expected range. Generally, more coarse soils with larger particles have less pore space and thus higher dry densities. Clay-heavy soils can be expected to have dry densities closer to 1.2, loams average 1.36, and sandy soils can have dry densities over 1.5. If your soil sample dry density is not within + or - 0.2 $\frac{g}{cm^3}$ of what is predicted by your soil type this likely indicates a problem with the sample.

Estimation of soil type by web soil survey:

1. Navigate to websoilsurvey.sc.egov.usda.gov/App/HomePage.htm. This should be the first result from most internet search engines if you type in "web soil survey."
2. Once on the page click on the green button labeled "Start WSS."
3. At the upper left portion of the page you should see five tabs labeled "Area of Interest (AOI)," "Soil Map," "Soil Data Explorer," "Download Soils Data," "Shopping Cart (Free)." Make sure you are on the "Area of Interest (AOI)" tab.
4. Zoom in on the map to the plot where you plan to take soil samples (this may take a few minutes).
5. Click on the tool labeled "AOI" at the top of your screen under the heading "Area of Interest Interactive Map." Using this tool outline the area of the map in which you intend to take soil cores and then release the mouse. The area you have selected should appear in cross hatching now. Once again, this may take a minute.
6. At the top of the page switch from the "Area of Interest (AOI)" tab to the "Soil Map" tab. The area you highlighted should now appear on the left-hand side of your screen in a box marked "Map Unit Legend." There should be a soil type listed under "Map Unit Name" with a link provided. Click on it.
7. This link should provide some estimated specifics about your soil type at both above and below 7". This is useful since you will be taking soil samples at 0-2" and 7-9". Mark down the soil types for the 0-7" and 7-60" range.

Estimation of Soil Type by Master Gardener Field Test:

1. Soil Texture by Feel instructions can be found for reference at www.ext.colostate.edu/mg/gardennotes/214.pdf. Print these instructions.
2. Go to your measurement site with a trowel when conditions have been wet, or bring a water bottle with some water if soils are dry.
3. Dig out a sample of roughly golf ball size from the top two inches of soil and then follow the flow chart instructions below (from Figure 5.4 of the "Estimating Soil Texture" printout to determine soil type).

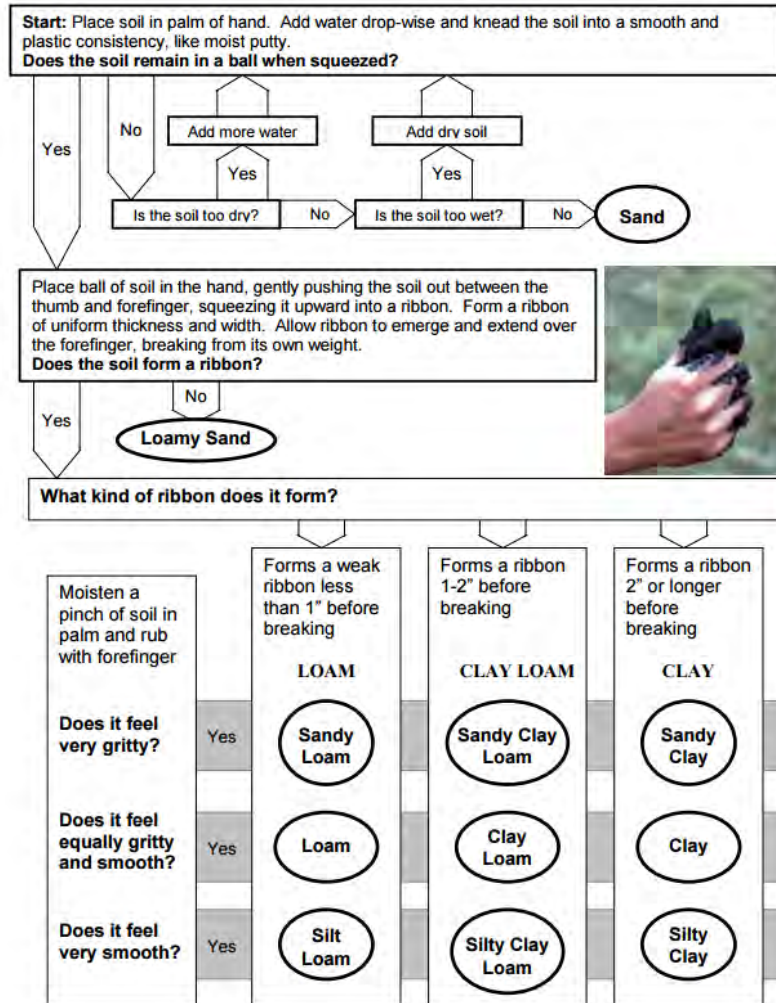

4. Repeat the process for soil of 7-9" depth.

If both of the soil type estimation techniques indicate that there is a significant amount of clay or silt in your soil (ie clay, silty clay) expect dry density of your samples to be $< 1.3 \frac{g}{cm^3}$. If both of the soil type estimation techniques indicate that there is a large amount of sand (ie sand, loamy sand) in your soil expect dry density measures to be $> 1.4 \frac{g}{cm^3}$. For loam-heavy types such as loam, clay loam, and silt loam a range between about $1.25-1.45 \frac{g}{cm^3}$ is to be expected. More generally, clays and silts fall on the less dense end of the anticipated $1.1-1.6 \frac{g}{cm^3}$ spectrum, and sands tend to be on the more dense side. If there is disagreement between the two estimation techniques you may proceed, but with less confidence about what dry density measurements you may obtain.

Site Requirements:

1. The location which you choose to dig must be flat, or close to flat, as must be the area around it. Because of runoff, soil moisture may be lower than representative of average at the top of mounds or hills, and higher than representative of average at local minima in elevation.
2. THE SITE CANNOT BE IRRIGATED: CoCoRaHS aims to depict conditions representative of a natural environment. Soil moisture measurements from an irrigated site are a better reflection of irrigation schedule than natural climate conditions.
3. Your dig site does not have to be barren, but surface vegetation should be pulled before taking a core sample. This helps to keep the proportion of organic matter in the sample as low as possible.
4. Just as in siting a rain gauge please try to take observations on a plot that is not in a place where falling precipitation may easily be interrupted by a large obstruction such as a house or a tree. A horizontal distance of more than two times the height of the obstruction is preferential.

Sampling Depths:

1. 0-2"
2. 7-9"

Sampling Patterns:

You will have some leeway to choose how and where samples are taken. The 0-2" soil samples have the potential to be used in calibration-validation effort by the National Aeronautics and Space Administration's Soil Moisture Active-Passive Satellite (SMAP). The 7-9" samples are suitable for aiding in the drought monitoring process, which is an operation lead by the United States Department of Agriculture. An example will be given below of how to report 0-2" soil samples only, and how to report at both standard depths.

One sample surface measurement pattern (GLOBE SMAP Block Pattern):

Soil Deep Block Pattern

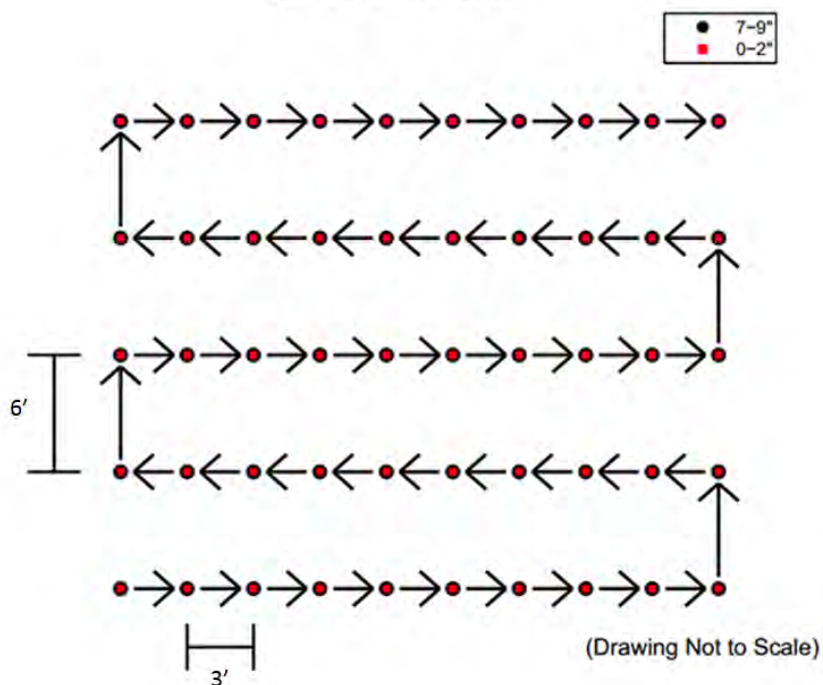

Take one soil core at 0-2" depth. Dig a hole down to 7" depth with a shovel. You will have to remove much more soil in order to take these deeper measurements, so measurements from one observation to the next will be farther apart (one yard recommended). On one side of the hole that goes to 7" dig an elongated section. This will make removing your root zone soil core much easier. Once you have removed the 7-9" core fill the hole you have dug back in as much as possible. The next nine times you take samples take them in a line perpendicular to the elongated hole that was dug to reach 7". Take these samples each one yard apart. On the 11th sample move two yards in a direction perpendicular to your previous line of measurements and parallel to the elongated holes that have been dug to 7". Continue on in a snake-like pattern. You may deviate from this pattern slightly to avoid rocks and root clusters.

Three sample surface measurement and root zone measurement pattern (CoCoRaHS Ideal Soil Moisture Measurement Pattern):

Necessary CoCoRaHS Materials:

1. 2" (50.8 mm) height 3.125" (79.4 mm) diameter brass ring *available from onlinemetals.com*

http://www.onlinemetals.com/merchant.cfm?pid=22612&step=4&showunits=inches&id=84&to_p_cat=79

Once on this webpage select the “Create a Custom Size” tab. In the box labeled “Length – Inches:” select 2. This should bring the listed cost/piece to \$6.38 before shipping and handling.



2. CoCoRaHS Metric Scale *available at www.weatheryourway.com*



Other Materials:

1. Pad, paper, and pencil/pen
2. Ruler
3. Level, or straight edge
4. Trowel
5. Graduated Cylinder (at least 100 mL, and wide enough for small roots)
6. Tin foil, cookie sheet, or pot pie holder
7. Oven
8. Sharpie (or similar labeling device)
9. Rag or paper towel
10. Shovel
11. Bucket scoop, or similar flat surface

12. Ziploc bag
13. Wood block (large enough to cover cylinder)
14. Full water bottle
15. Gloves (optional)
16. Masking Tape (optional)

Soil Coring:

1. Bring your pencil, paper, ruler, level (straight edge), brass ring, bucket scoop (or similar thin, flat surface), scale, Ziploc bag, sharpie, masking tape, hammer, wooden block, and trowel to your selected dig site.
2. Weigh the bag that will be used to hold your soil core. This weight can be subtracted when weighing the sample.
3. Remove surface vegetation from your dig site. You only need to do this right where you are digging. You do not need to clear a large area around the dig site. One square foot is enough.
4. Place the brass ring on a flat portion of soil and twist it into the ground a bit to clearly designate a core site. If the soil is soft, continue to push; you may be able to push the ring in with your hand.
5. Put the wood block on top of the brass ring, and then hammer it into the ground until the block is flat against the surface.
6. Using the trowel, excavate the soil surrounding one half of your brass ring down to the depth of the bottom of your sample. Make sure you have excavated enough area to lay the bucket scoop flat in the pit.
7. Slide your soil core contained by the brass ring horizontally over the surface of the bucket scoop. Be careful not to lose any of your soil core through of the bottom of the ring, especially if soils are dry.
8. Slide the soil core into your Ziploc bag.
9. Break up the soil core, and remove any rocks larger than a pea, and any roots larger than a q-tip.
10. Squirt some water from your water bottle into your graduated cylinder, and measure that volume.
11. Now drop the rocks and roots you removed into the graduated cylinder and read the volume again. The difference in volume between these two measurements is equal to the volume of rocks and roots removed, and should be subtracted from your container volume when determining the sample's dry density and volumetric water content.
12. Weigh your soil sample and record it being sure to tare the weight of the bag.
13. Label your sample with the date, time, volume of rocks and roots removed, and depth of measurement. You may prefer doing this with masking tape, and a sharpie or pen to avoid marking directly on the bag.
14. Clean off your trowel with a dry rag or paper towel to avoid sample cross-contamination.
15. (Optional) Now it's time to get your 7-9" depth sample. Dig down to 7". These measurements should be taken directly below where you took your 0-2" measurements. Be conscientious of

how far you've dug. You can use the ruler to measure the depth, and a level, or just a straight edge, to make sure the ruler is lined up perpendicular to the ground. Once you have dug out soil to 7" depth repeat steps 5-14 for your deeper sample. Be careful of debris falling into the hole from nearer the surface. You want to make sure 7-9" soil cores are actually representative of undisturbed soils at depth.

The Drying Process:

1. Have the following materials on hand: pencil and paper, drying surface (ie tin foil, cookie sheet, pot pie holder), and scale.
2. Set and your oven to 210-215 F and let it preheat.
3. Weigh the drying surface you wish to place your soil sample on, so that this weight can be subtracted in your calculation.
4. Carefully pour your soil sample from the Ziploc bag onto the drying surface, and spread it out. If you are using tin foil, fold up the corners before pouring the soil to avoid mass loss.
5. Weigh your sample again before placing it in the oven. This weigh-in is designed to corroborate your field measurement, but on a consistent, flat surface such as a counter top. If the sample has changed in weight by a few grams or less it is likely due to evaporation and not a scale error during the soil coring process.
6. Once the oven has preheated place the soil sample in the oven, and wait!
7. Remove the soil from the oven occasionally to weigh it. Wait several hours before doing this, and more frequently afterwards. Once there has been no measurable evaporation for at least half an hour you may proceed. After getting to know your soil you may gain some intuition for how long the drying process takes based on how wet it is.
8. Once the soil weight no longer changes over at least one half hour period it is done.
9. Repeat steps 1-8 as needed in order to dry all your samples. There's no limit to how many you're allowed to oven-dry at once so long as it can be done without sample cross-contamination.

Bulk Density and Volumetric Water Content Calculations:

- A density is simply a mass divided by a volume. The bulk density of your sample is the weight of the contents of the sample once dried divided by the volume of the brass ring.

Bulk Density = dried soil mass/(brass ring volume - volume of rocks and roots)

- Since fresh water has a density of 1 gram/cm³ the volumetric water content can be obtained by dividing the difference in wet and dry weight by the volume of the brass ring, and then multiplying by 100. This is expressed in the following simple formula:

$$\text{WVC (\%)} = 100 * [(\text{wet weight}) - (\text{dry weight})] / (\text{brass ring volume} - \text{volume of rocks and roots})$$

Make sure you have converted your container volume to cm^3 so that the expression is unitless!

Reporting the data:

Until CoCoRaHS soil moisture is no longer in a test phase you will have the option to fill out spreadsheets via excel (or a comparable program) and email them back to CoCoRaHS headquarters, or mail in spreadsheets filled out by hand. A standardized interactive submission form on the website should be made available by Fall 2016. An example spreadsheet has been attached as well as a sample plot generated from the example spreadsheet for your reference.

We request that the following information be placed in the top six rows of your spreadsheet:

1. Name (optional)
2. Longitude and latitude
3. Station ID
4. 0-2" estimated soil type
5. 7-9" estimated soil type
6. Soil drying device

The following fields need to be filled out as a part of the spreadsheet:

1. Date
2. Time
3. Sample depth (ie 0-2", or 7-9")
4. Sample number (if you are taking multiple samples at one or both depths)
5. Volume removed
6. Sample weight
7. Pre-dry weight (weight right before the sample is placed in the oven)
8. Dry weight
9. Bulk density $\frac{g}{\text{cm}^3}$
10. Volumetric water content (%)
11. Average volumetric water content (if you take multiple samples at the same depth. Note: This is NOT an average of volumetric water content between the surface and the root zone)
12. Comments (if applicable)

Measurement Intervals:

Because measuring volumetric water content is much more time-intensive than a precipitation measurement we do not have a required measurement schedule at this time, and it is not expected that you take soil cores any more frequently than once a week. Measurements are not recommended when soil freezes, and or when snow cover exists. The value of soil core measurements maximizes during the growing season. Here are several recommendations for measurement schedules you are welcome to try:

1. Synchronize your measurements with NASA's SMAP flyover schedule. Details can be found at http://smap_op.apps.nsidc.org/
2. Take a weekly, biweekly, or even monthly measurement at a time that is most convenient
3. Try measuring soil moisture before a large storm, and for several days following the storm
4. Try more frequent measurements when your area is descending into, or recovering from drought
5. It is not recommended that soil moisture measurements be taken at night. Hours during the middle of the day with intense sunlight should likewise be avoided unless that corresponds to the SMAP flyover schedule. Morning and evening observations are preferred.

Questions or Concerns:

Please direct your questions to info@cocorahs.org, or peter@cocorahs.org.

PROJECT TITLE: CIRA Collaboration with ESRL Physical Sciences Division on Hydrologic Research and Water Resources Applications Outreach Coordination

PRINCIPAL INVESTIGATOR: Lynn E. Johnson, Sher Schranz

NOAA TECHNICAL CONTACT: Rob Cifelli (NOAA/OAR/ESRL/PSD/HMA)

NOAA RESEARCH TEAM: V. Chandrasekar (CSU), Jungho Kim (CSU)

FISCAL YEAR FUNDING: \$7,338

PROJECT OBJECTIVES:

1--Hydrologic Research and Applications Development:

Objective: Provide expert guidance and consultation on hydrologic applications for the HMA Team

2--Distributed Hydrologic Modeling (DHM) for Flash Flood Operations:

Objective: Assess distributed hydrological models for NWS flash flood forecast and warning operations.

3--Forecast-Based Operations Optimization (FBO-O) Project:

Objective: improve precipitation and river flow forecasting to maximize water capture.

4--Russian River Tributaries Water Budget Project:

Objective: Develop a hydrologic water budget model that estimates historical (unimpaired), current (impaired) and future flow conditions of selected Russian River tributaries.

5--San Francisco Bay Coastal Flooding Forecast Project

Objective: Demonstrate the interoperability of the USGS CoSMoS and NOAA DHM prediction models, and application of these for coastal flooding mitigation planning and prototyping for real-time flood warning operations.

PROJECT ACCOMPLISHMENTS:

1--Hydrologic Research and Applications Development:

--Assisted in the design, coordination and development of hydrological modeling and water resources management applications for regional demonstrations with the Hydrometeorological Testbed (HMT) and NWS National Water Center (NWC).

--Provided guidance and leadership in carrying forward the hydrological research agenda defined by the HMA Team, including publication in technical reports, peer-reviewed journals, and conferences.
--Supported the HMA Team Leader in identifying and tracking candidate (and past) tools, techniques and knowledge transfers to NWS and key stakeholders.

2--Distributed Hydrologic Modeling (DHM) for Flash Flood Operations:

Major activities included:

--Implemented the Research Distributed Hydrological Model (RDHM) for the Russian and Napa River basins within the NWS Community Hydrologic Prediction System (CHPS) for near-real time data ingest and simulation capability.
--Developed a web mapping-based Hydrologic Visualization Tool (HVT) (Figure 1) to include: threshold exceedance identifying criticality of flooding, at-risk road crossings, and locations of critical infrastructure.
--Conducted preliminary assessments with NWS WFO forecasters and other users for DHM forecast accuracy and usability for flash flood operations.

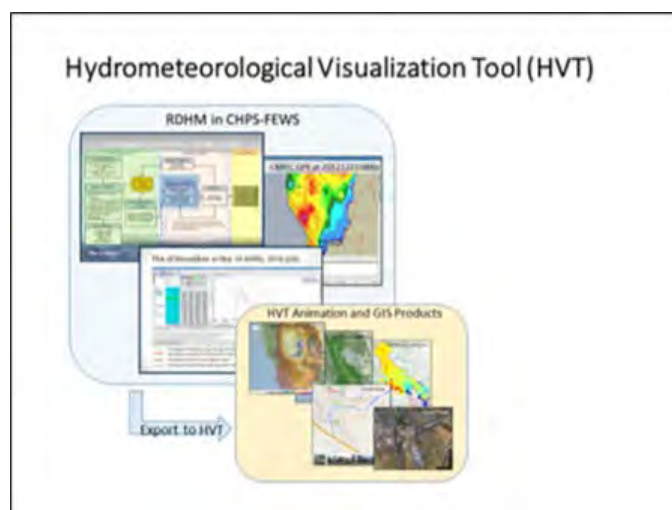

Figure 1. HVT web service provides interactive access to information on forecast flash flood levels and criticality, and flood impact features (e.g. bridge crossings).

3--Forecast-Based Operations Optimization (FBO-O) Project:

--Work to date on this project has focused on setting up the framework for a dynamic programming optimization model for the Russian River basin using the generalized dynamic programming software package CSUDP developed at Colorado State University.
--Preliminary development of the CSUDP model has included programming of the logic for the Lake Mendocino operating rules, but with further refinement and adjustment through interaction with HEC and SCWA personnel.
--The next task is to link the CSUDP model with the HEC-WAT river basin simulation and analysis package, as well as incorporating SCWA water supply requirements.

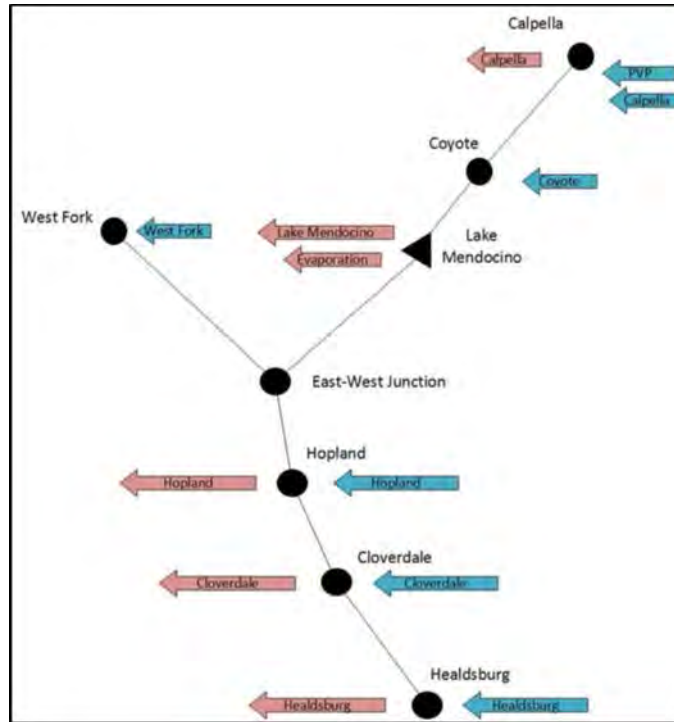

Figure 2. Network flow diagram of the monthly dynamic programming model based on the historical unimpaired flows.

4--Russian River Tributaries Water Budget Project:

--A hydrologic water budget model has been developed for the Feliz Creek watershed within the Russian River basin by combining the RDHM streamflow simulation model with the GIS-based Geo-MODSIM network streamflow model. (Figure 3)

--A web-based interface has been developed for the dissemination of information to project stakeholders.

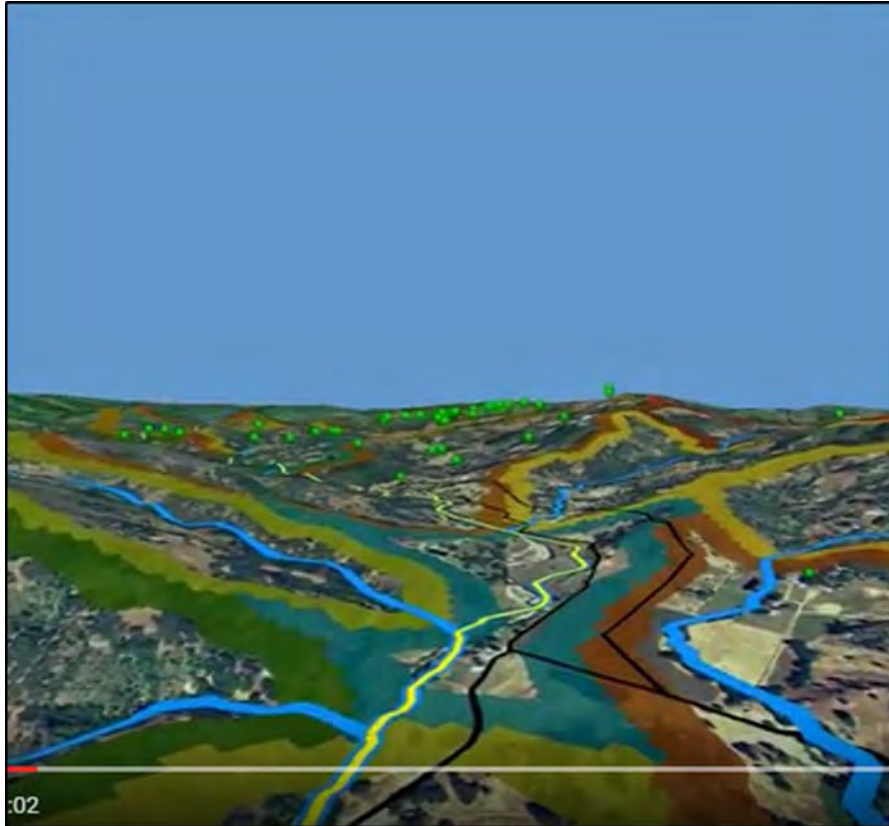

Figure 3. Watershed visualization of Feliz Creek fisheries habitat portrays flow levels along stream reaches.

5--San Francisco Bay Coastal Flooding Forecast Project

- Napa River fluvial runoff scenarios generated and provided as input to the CosMos coastal storm surge inundation model. (Figure 4)
- CosMos simulation of SF Bay storm surge scenarios with Napa River fluvial inflows.
- Animation of coastal storm surge and river inflow flood inundation time series.
- Design of table-top exercise for coastal/fluvial flood simulation exercise to be held with California DWR and local emergency response agencies (to be held ~May 2017).

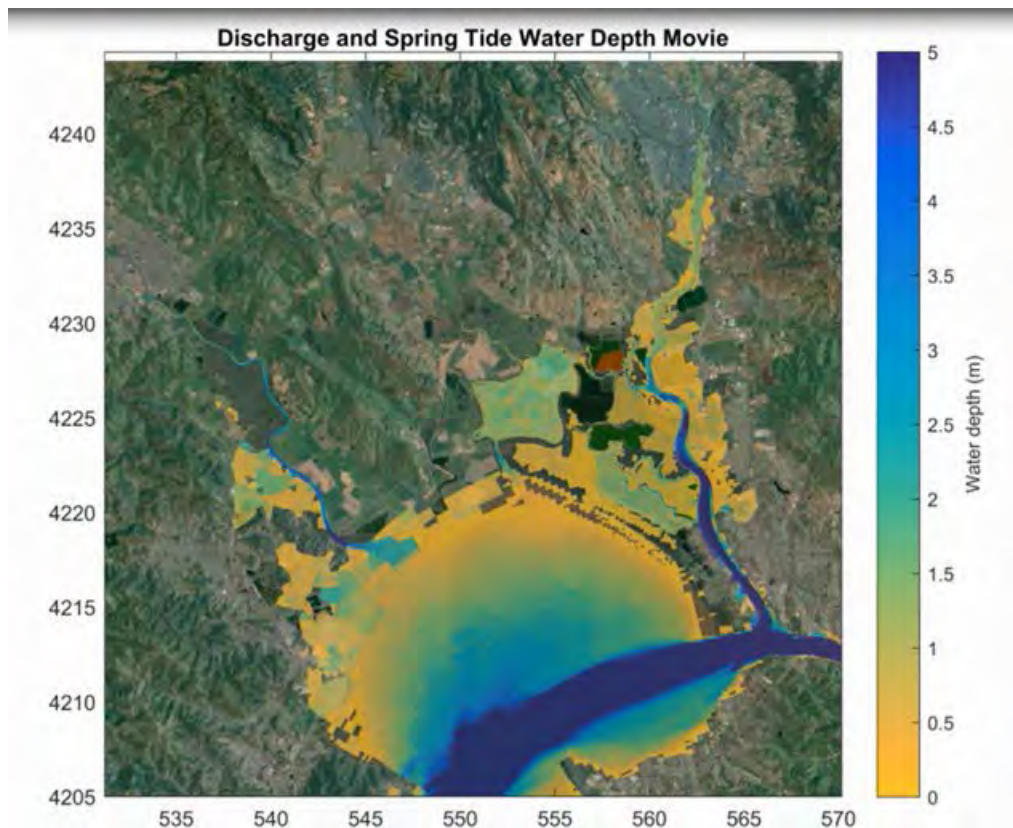

Figure 4. Coastal flood inundation mapping for Napa River estuary.

Publications:

Johnson, J. E., J. Halgren, R. Cifelli, T. Coleman, J. Labadie and G. Park, 2016: Assessment of Distributed Hydrological Modeling for NWS Flash Flood Operations - Russian-Napa Rivers, CA. 7th NOAA Testbed and Proving Grounds Workshop, College Park, MD, NOAA. (Available online at: http://www.testbeds.noaa.gov/events/2016/workshop/abstracts/pdf/2016ThemeSessionAbstracts_Johnson.pdf)

Johnson, J. E., J. Halgren, R. Cifelli, T. Coleman, J. Labadie and G. Park, 2017: Distributed Hydrological Modeling for NWS Flash Flood Operations. 33rd Conference on Environmental Information Processing Technologies, Seattle, WA, Amer. Meteor. Soc., 3A.5. (Recorded Presentation available at: <https://ams.confex.com/ams/97Annual/webprogram/Paper309914.html>)

Kim, J., L. E. Johnson, R. Cifelli, and V. Chandrasekar, 2017: Soil Water Retention Curve (S-curve). Hydrological Processes, submitted.

Kim, J., L. E. Johnson, R. Cifelli, and V. Chandrasekar, 2016: Soil Water Retention Curve (S-curve). Fall Meeting, San Francisco, CA, Amer. Geophys. Union, H21c-1420. (Available online at:

PROJECT TITLE: Enhancing NIDIS Drought Monitoring and Early Warning in the Upper Colorado River Basin

PRINCIPAL INVESTIGATOR: Nolan Doesken

RESEARCH TEAM:

Nolan Doesken (State Climatologist and Principle Investigator)
Becky Bolinger (Climate monitoring and drought diagnostics, web page development, climate prediction)
Peter Goble (Climate monitoring and drought diagnostics, soil moisture integration, evapotranspiration)
Zachary Schwalbe (GIS specialist, weekly monitoring, data display)
Henry Reges (communications and outreach, condition monitoring)
Noah Newman (social media, webinar, metrics)
Julian Turner (Condition Monitoring, Soil moisture data infrastructure, database support)

NOAA TECHNICAL CONTACT:

Veva De Heza, NIDIS Program Office, Boulder, CO
Sandy McClellan, CNT Contractor and budget analyst for NOAA/National Integrated Drought Information System (NIDIS)

NOAA RESEARCH TEAM: Alicia Marrs, Kathleen Bogan (NIDIS program office, Boulder CO)

FISCAL YEAR FUNDING: \$125,000

PROJECT OBJECTIVES:

- 1--Continue to provide and improve weekly drought assessment services.
 - 2--Incorporate and promote the new "Evaporative Demand Drought Index" (EDDI)
 - 3--Assess and incorporate soil moisture monitoring capabilities as a means of enhancing drought early warning.
 - 4--Continue efforts to better engage key representatives (National Weather Service, U.S. Bureau of Reclamation, State Engineers Offices and local River Commissioners, etc.) from the UCRB and surrounding regions in effective drought monitoring, early warning and coordination. In particular, identify effective partners in WY and UT.
- Other activities as time/resources allow –
- 1--Maintain a two-tiered UCRB DEWS communications and contact list – refreshed quarterly
 - 2--Meet primary stakeholders – discuss special needs and drought early warning opportunities associated with hitting potential shortage criteria in Lake Powell-Lake Mead in the near future
 - 3--Explore and improve drought impact reporting

PROJECT ACCOMPLISHMENTS:

This project began 1 July 2015. This reporting period covers much of the 2nd half of the project effort, although work is ongoing and has not been completed. Our current and future efforts have been greatly enhanced by the recent hiring of two full-time staff to support climate services and drought monitoring work. Becky Bolinger, and Peter Goble, both who previously did their graduate level research supported by the NIDIS UCRB DEWS, joined the Colorado Climate Center staff in October 2016 immediately adding experience, energy and creativity to our team.

Our single largest and highest impact activity throughout this reporting period was our weekly climate/water/drought updates. These were produced all 52 weeks during the year including major holidays. Each week, upon completion of this assessment each Tuesday, dissemination first goes out to about 30 weather, climate and water professionals in CO, WY and UT for critique. Then, after receiving their feedback, the report (which consists of recommended changes to the US Drought Monitor maps for CO, UT and southwest WY) is then sent to the US Drought Monitor weekly author late each Tuesday afternoon. The dissemination then goes out broadly Tuesday evening or Wednesday morning to several hundred interested users. Dissemination often motivates discussions with USDM authors, stakeholders such as Farm Service Agency staff, and also interviews with media – particularly during times of worsening drought severity.

Some of the weekly updates are produced as interactive webinars with presenters from our team supplemented by streamflow briefings by USGS hydrologists, weather forecasts by NWS forecasters, and seasonal climate outlooks presented by Klaus Wolter from the Univ. of Colorado. As observed in previous years, our best attended webinars were those that included (and advertised) a seasonal prediction emphasis. Likewise, the most interactive and engaged discussions occur when CCC staff track the attendance roster of the webinar and actively call on attendees to request their comments and input.

Summarizing what we experienced this past year in terms of climate, water and drought; water supplies and reservoir storage remained quite good with near to above average snowmelt runoff over most of the area in April, May and June. This was followed by a dry summer in some areas, and very dry autumn over most of the region with growing drought concerns as we moved through November (Figure 1). A dramatic turnaround then took place with very heavy, wet mid-winter snow in December, January and parts of February in the mountains, while the eastern plains of Colorado remained quite dry (Figure 2). Temperatures once again were above average, especially during summer and fall of 2016 and the late winter of 2017. However, reference evaporation during the 2016 growing season was near or below average over most irrigated areas of the region – reducing the evaporative stress on crops (Figure 3).

Several additions and improvements were made to the weekly assessment and USDM update process.

1--We began to adapt to a NIDIS Program Office decision to include Arizona and New Mexico in our Drought Early Warning area and change our name to the “Intermountain West Drought Early Warning system”. To this end, we worked with a CSU Extension videography sociologist to guide more effective briefer communications formats. The discussion-style webinar format is still needed to accommodate open discussion and more in-depth details but many listeners/users would appreciate shorter more compressed presentations.

2--routine use of the Evaporative Demand Drought Index (EDDI) in our weekly assessments and disseminated products

3--Redesigned the NIDIS IMW Climate, Drought, and Water Assessment website (<http://climate.colostate.edu/~drought/>)

4--Updated the NIDIS IMW webinar format (web-based instead of PowerPoint)

5--Utilized soil moisture anomaly graphs to help depict in-soil moisture conditions.

6--Developed CoDEX, a tool that blends all drought indicators and gives a “convergence of evidence” approach to a specific drought category to provide guidance on a relatively coarse basin-wide scale to suggest area where we may be under or over-representing the severity of drought.

We continued to coordinate our efforts with other groups doing similar work including the newly forming “Upper Missouri River Basin Drought Early Warning System”. Wyoming immediately became quite engaged in that activity compared to their relative low engagement in the Upper Colorado River DEWS. This is not surprising since the majority of WY population, land area and economic activity occurs within the Missouri River Basin portion of their state. This is actually improving collaborative activities. We continued to coordinate activities with the Colorado Basin River Forecast Center. We attended the annual stakeholder meeting of the Western Water Assessment – another key partner in the DEWS. We attended

the North American Drought Monitor Forum in Fort Worth, TX (June 2016). We participated in NIDIS-sponsored Drought & Climate Outlook meetings near Tucson, AZ (September 20-21, 2016) and Denver, CO (October 25, 2016). In March 2017 we sent a representative to Champaign, IL to contribute to planning the Midwest DEWS and strategies for using state Mesonets for drought monitoring and early warning.

Colorado Climate Center staff continued to widely promote the NIDIS IMW DEWS activities. Dozens more interested individuals and organizations were added to the e-mail list to receive weekly updates. We conducted a comprehensive update of “local water supply and drought impact experts” list for the 3-state region. This required hundreds of calls and e-mails as there tend to be many personnel changes on this extensive list – particular within conservation districts, NRCS county offices, Extension offices, resource management and water districts. We originally planned to do quarterly updates to our “expert” list, but we’ve decided that an annual update may be sufficient. We are exploring ways to do this more efficiently.

The six-minute YouTube animation we completed in June, 2015 (<https://youtu.be/i7F6QwRqyVI>). “Assessing Drought in the United States” is gaining traction as a simple and understandable way to explain the US Drought Monitor process. There have now been about 15,000 views and the number increases daily.

Peter’s work on soil moisture monitoring has continued and is explained in the NIDIS Soil Moisture monitoring final project report submitted to CIRA. His work has resulted in an appointment to the National Soil Moisture Monitoring Network advisory committee. Becky’s work on drought outlooks has already resulted in a conference presentation “Developing a Drought Outlook Product for the NIDIS Intermountain West Drought Early Warning System” at the AMS Annual Meeting, January 24, 2017

We have continued to make progress on several of the second tier objectives as well. For example, we routinely follow water levels and potential impacts of trends in those levels in Lake Powell and Lake Mead. Lake Powell reservoir levels are now routinely displayed and updated in our assessment reports. We are now engaged with the US Bureau of Reclamation, the Upper Colorado River Commission and partners in NM, UT and WY in a multistate effort to more closely track crop water use in the UCRB. We are assisting in finding a suitable site for an eddy covariance flux tower near Fruita, Colorado and we have found sites and hosts for 10 new Colorado Agricultural Meteorological Network (CoAgMet) stations in various irrigated river valleys throughout western Colorado (Figure 4). These stations should be installed in the next 3 months and will be used to improve estimates of crop water use in hay meadow environments in agricultural valleys of western Colorado. These stations are in very data sparse areas. Stations are also being added in UT, WY and NM. Collectively these stations will be advancing our drought monitoring capabilities while also potentially influencing water management policies and administration in times of drought.

We have continued our effective collaboration with the NIDIS-supported Carolina’s Integrated Science Assessment (CISA) in an effort to improve and increase the reporting of drought impacts. Based on testing and evaluation conducted by CISA staff and students working with volunteers in the Carolinas and Georgia, we implemented an improved “Condition Monitoring Report” form across the entire CoCoRaHS (Community Collaborative Rain, Hail and Snow) network in October 2016. This form, as shown in Figure 5, has a scale bar for reporting relative wetness or dryness that is a simple, attractive and unthreatening way to encourage volunteers to assign somewhat quantitative categories to otherwise qualitative information—descriptions of plants conditions, animal sightings and activities, and other current conditions. This, along with the objective precipitation measurements taken by the volunteers is showing considerable promise for expanding the value and applications of volunteer data while providing a satisfying educational experience for the volunteers. So far, volunteer response has been excellent. Rather than getting just a few hundred CoCoRaHS “Drought Impact Reports” we have already received over 8,000 “Condition Monitoring Reports” in less than 6 months. On our end this required that we

- Helped to finalize the requirements and data structure for the Condition Monitoring Protocol
- Developed, tested and implemented new Condition Monitoring Form on the CoCoRaHS cyberinfrastructure
- Developed GeoJSON data feed for use in Condition Monitoring Maps in the Carolinas
- Developed XML data feed for use by the Drought Impact Reporter

In the coming months, we hope to implement nationwide mapping of “Condition” reports with the anticipation that seeing reports on maps and watching national trends in drought development and amelioration, that even more volunteers will begin to help gather and share data. We also hope to develop and promote “Condition Monitoring” publicity and training cartoon animations similar in for to the U.S. Drought Monitor animation described above.

Finally, the CCC NIDIS IMW DEWS team has been working closely this year with NIDIS staff and other NIDIS partners (WWA, CLIMAS, etc.) on developing and refining a two-year strategic plan that will include tangible milestone and measurable outcomes. Future work activities will likely be guided by this plan. This will also help partnerships and collaboration with the emerging Upper Missouri River Basin DEWS and the Midwest DEWS.

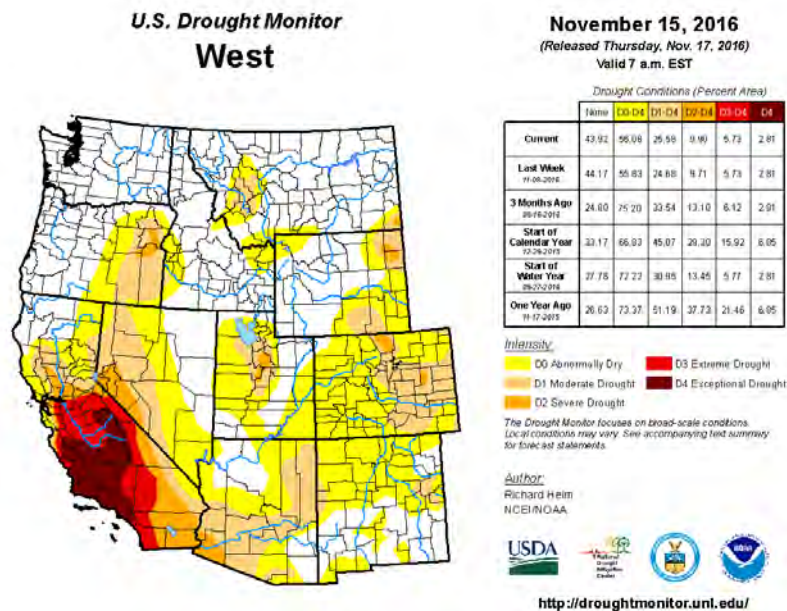

Figure 1. U.S. Drought Monitor for November 15, 2016 showing expanding dryness in the Central Rocky Mountain region

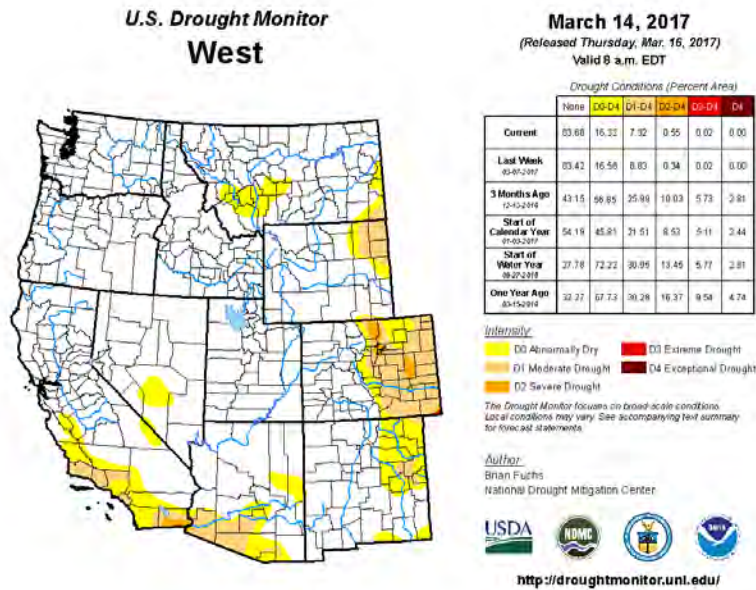

Figure 2. U.S. Drought Monitor for March 14, 2017 showing drought-free conditions over much of the IMW but expanding dryness east of the mountains

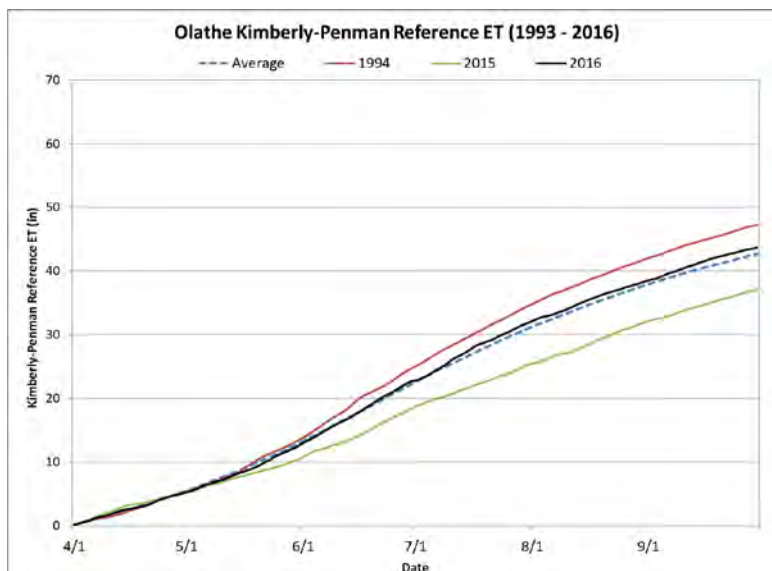

Figure 3. 2016 growing season accumulated Ref ET compared to average or extreme for Olathe, CO showing ET was near average for the year despite warmer than average summer temperatures.

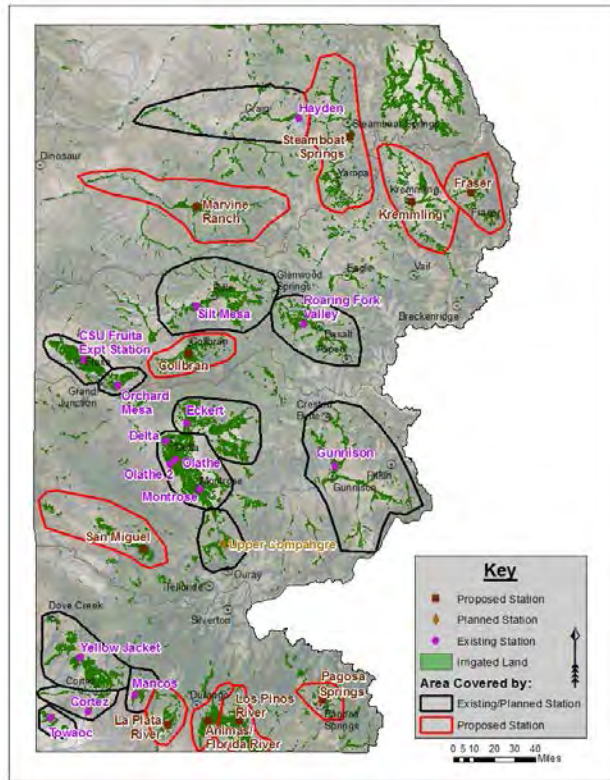

Figure 4. Locations of new weather stations in the Upper Colorado River Basin in Colorado. These stations are slated for installation in 2017 for the purposes of better measuring crop water use.

Condition Monitoring Report Form Submit Data Reset

Station Number : CO-LR-1049
 Station Name : Fort Collins 0.3 SSE

Condition monitoring reports are submitted on a regular (weekly, biweekly, monthly) basis to share information about the effects of local precipitation on the environment and society. By submitting reports on a regular basis, you create a baseline to see change through time, such as seasonal differences or changes caused by more or less precipitation. Please refer to the [Condition Monitoring training slide show](#) for more information.
 * Indicates required field

Report Date *
 4/3/2017

Condition Scale Bar [More information on the scale bar](#) Clear Scale Bar

Severely Dry	Moderately Dry	Mildly Dry	Near Normal	Mildly Wet	Moderately Wet	Severely Wet
<input type="radio"/>	<input type="radio"/>	<input type="radio"/>	<input type="radio"/>	<input type="radio"/>	<input type="radio"/>	<input type="radio"/>

Description
 Please provide a description of how dry, normal or wet conditions are affecting you, your livelihood, your activities, etc. *

Report Categories
 Please check at least one report category. If you check a category, please provide supporting information in the description. [More information on condition monitoring categories.](#)

- General Awareness
- Agriculture
- Business And Industry
- Energy
- Fire
- Plants And Wildlife
- Relief Response
- Society And Public Health
- Tourism And Recreation
- Water Supply And Quality

Submit Data Reset

Figure 5. CoCoRaHS “Condition Monitoring” report form developed jointly with the CISA to improve public participation in drought impact reporting in the U.S.

Publications:

Bolinger, B “Developing a Drought Outlook Product for the NIDIS Intermountain West Drought Early Warning System” AMS Annual Meeting, Seattle, WA January 24, 2017

Doesken, N., 2016. Drought Monitoring and Early Warning in Colorado. Colorado Water, Newsletter of the Water Center of Colorado State University, vol. 33, 3 (Jul/Aug), pp. 22-23.

Doesken, N., 2016. Climate Trends in Colorado over the Past Century. Colorado Water, Newsletter of the Water Center of Colorado State University, vol. 33, 1 (Mar/Apr), pp. 10-13.

Goble, P., Nolan Doesken and Russ Schumacher, 2016. Using Reanalysis Data to Find Signal Strength of Root Zone Soil Moisture. Colorado Water, Newsletter of the Water Center of Colorado State University, vol. 33, 2 (May/June), pp. 22-25.

PROJECT TITLE: Expanding Precipitation Measurements in the Commonwealth of the Bahamas through the CoCoRaHS (Community Collaborative Rain, Hail and Snow) Network

PRINCIPAL INVESTIGATOR: Nolan Doesken

RESEARCH TEAM: Henry Reges, Julian Turner and Nolan Doesken

NOAA TECHNICAL CONTACT: Thomas Peterson (With NOAA NCEI but has recently retired – but still working with us through his involvement in the World Meteorological Organization), Roger Pulwarty

NOAA RESEARCH TEAM: Thomas Peterson (With NOAA NCEI but has recently retired – but still working with us through his involvement in the World Meteorological Organization). Other NOAA entities are peripherally involved such as David Brown, Regional Climate Services Director, Southern Region NOAA National Centers for Environmental Information (NCEI), and Meredith Muth, International Programs Manager with NOAA's Climate Program Office.

FISCAL YEAR FUNDING: \$0

PROJECT OBJECTIVES:

Here was the proposed Scope of Work

1--Working with the Bahamas Meteorological Service, the first step would be to develop a leadership team composed of Bahamas nationals with members residing on several different islands ideally. Henry Reges will be serving as the CoCoRaHS liaison to the Bahamas for this project.

2--While travel funds are not requested in this proposal, a face-to-face meeting with CoCoRaHS leadership, the Bahamas Meteorological Service (BMS) and the NCEI representative to the World Meteorological Society's Committee on Climatology is highly recommended. Ideas for funding this meeting will be explored. The purpose of this meeting would be to set goals for number and locations of rain gauges and plan strategies for recruiting, training and feedback to participants. This would also be an ideal opportunity for doing an initial training session for BMS and partner organizations of their choosing. If travel is not possible, then electronic communications will be employed.

3--Set a target date for launch – hopefully sometime before 2016 hurricane season

4--Acquire and distribute CoCoRaHS 4" diameter, high capacity rain gauges (will provide 60 as part of this request) and training resources to the Bahamas CoCoRaHS leadership team.

5--While background work is being done in the Bahamas, Julian Turner at CoCoRaHS headquarters will be developing the website, database, data mapping and data export capabilities to support the CoCoRaHS Bahamas project. The scope of this effort is large and likely beyond the immediate budget, but CoCoRaHS will make some in-kind program investments to support this pilot/demonstration project. This effort requires the implementation of a robust international station naming and numbering system as well as metadata creation, archive and retrieval including the tracking of station status (open, active, inactive, closed). This will be patterned after the U.S.- Canada expansion but must accommodate or establish certain international CoCoRaHS standards.

6--When launch date has been selected and infrastructure is in place, promote a coordinated launch of the Bahamas CoCoRaHS demonstration.

7--Recruit, train and engage volunteers. Emphasize recruiting volunteers who have personal or professional interests in weather and water (this approach helps link data collectors and users as

demonstrated by years of CoCoRaHS experience). Display and track data, encouraging participants to view their rainfall observations to see variations and extremes in Bahamas precipitation and comparisons with Florida. Provide feedback to volunteers. This will all be done jointly between CoCoRaHS headquarters, the Bahamas Meteorological Service and other appropriate partners. We will encourage the Met Service to take the lead in providing support to volunteers.

8--One year from beginning, conduct assessment of numbers of participants, quantity and quality of reports, challenges and opportunities, as well as usefulness and accessibility of precipitation data.

9--Recognizing the scope and budget of this project, CoCoRaHS headquarters will pursue outside funding sources and/or additional partners if needed.

PROJECT ACCOMPLISHMENTS:

The Bahamas CoCoRaHS Volunteer Rainfall Network
Pilot Project 2016 Report
Henry Reges, Nolan Doesken
CoCoRaHS.org
Colorado State University,
Fort Collins, Colorado, USA

The following is a report on the history of the network's launch in the Bahamas, observations and growth during the Summer of 2016.

Background:

The Bahamas Department of Meteorology, in association with a United States-based organization, launched a volunteer rainfall-observing network 1 June 2016; which, within a week of its official launch, had already quadrupled the number of Bahamian rainfall measuring stations. This cost-effective network takes advantage of:

- Widespread advances in communication where a mobile phone can instantly send an observation anywhere in the world.
- Low cost observing instrumentation.
- Modern automated data processing.
- Precipitation data stakeholders, such as farmers, emergency managers, and water and sewerage corporations, volunteering to make observations.

In many parts of the world there are too few precipitation observations to adequately monitor local climate or hazardous conditions. This is often due to the cost of measuring equipment or the manpower to take these observations. With a new paradigm in mind, the idea of using low cost equipment, manned by volunteer observers, sprung to life in Fort Collins, Colorado after a devastating flash flood in July 1997. This idea of investing time and energy in the volunteer observers rather than the equipment, spread across the United States and as of 2016 over 20,000 volunteers (Figure 1) now use inexpensive rain gauges to measure precipitation throughout the United States, the Canadian Provinces, Puerto Rico, the U.S. Virgin Islands and most recently the Bahamas.

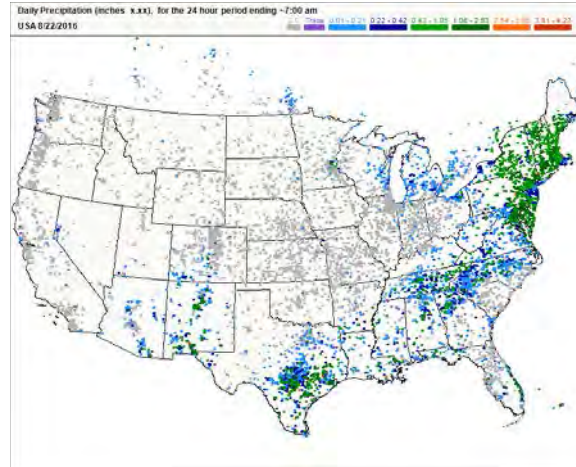

Figure 1. CoCoRaHS Daily Precipitation Map, (www.cocorahs.org)



Figure 2. CoCoRaHS 10.2cm (4") gauge

Officially launched on 1 June 2016, the beginning of the North Atlantic Hurricane Season, the Community Collaborative Rain, Hail and Snow Network (CoCoRaHS) (Reges, 2016) collaborated with the Bahamas Department of Meteorology to begin a pilot collaborative network of volunteer observers armed with 10.2cm (4") diameter high capacity plastic rain gauges (Figure 2) to measure rainfall throughout the family islands. With the launch of the program, daily observations of rainfall are now being measured by observers across the islands, some with a strong interest in the data (water and sewage corporation,

agricultural organizations, island municipalities, island schools, etc.) and others by curious individuals at their homes. A goal of at least five to ten observers per island was set. Observations are transmitted by observers using an App on their mobile device or via the internet on a computer. Observations are then immediately, processed by CoCoRaHS' central facility in Colorado, and made available to all stakeholders, including the Bahamas Department of Meteorology instantly at <http://cocorahs.org/Bahamas.aspx> (Figure 3)

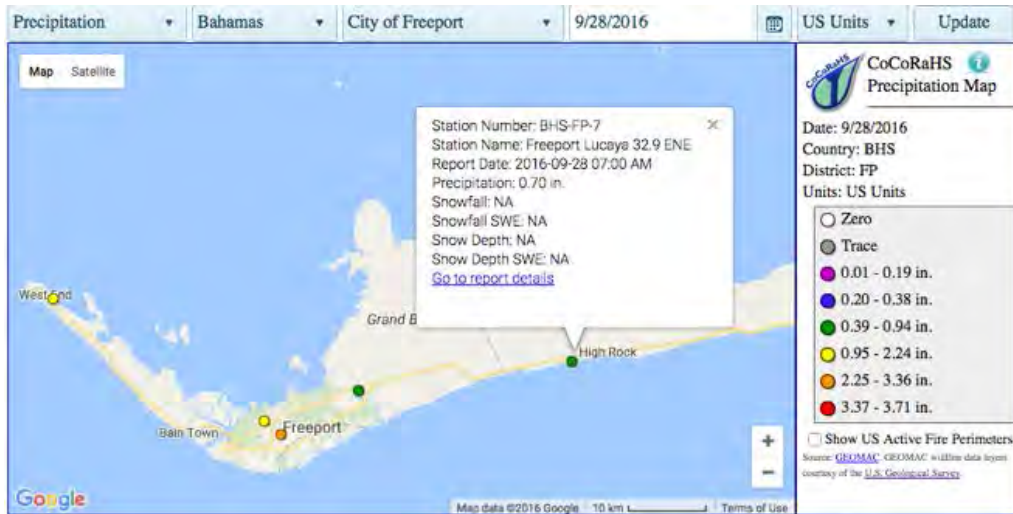

Figure 3. CoCoRaHS Bahamas Maps- Freeport.

Seven dozen rain gauges were donated by NOAA to this effort, with many being deployed during the summer of 2016. By having a much denser network of rainfall data across the islands, many new possibilities using this data set are possible. Locals traditionally say that one side of an island is drier or wetter than the other. Now with scientific data over a period of record, they will know if that is true or not.

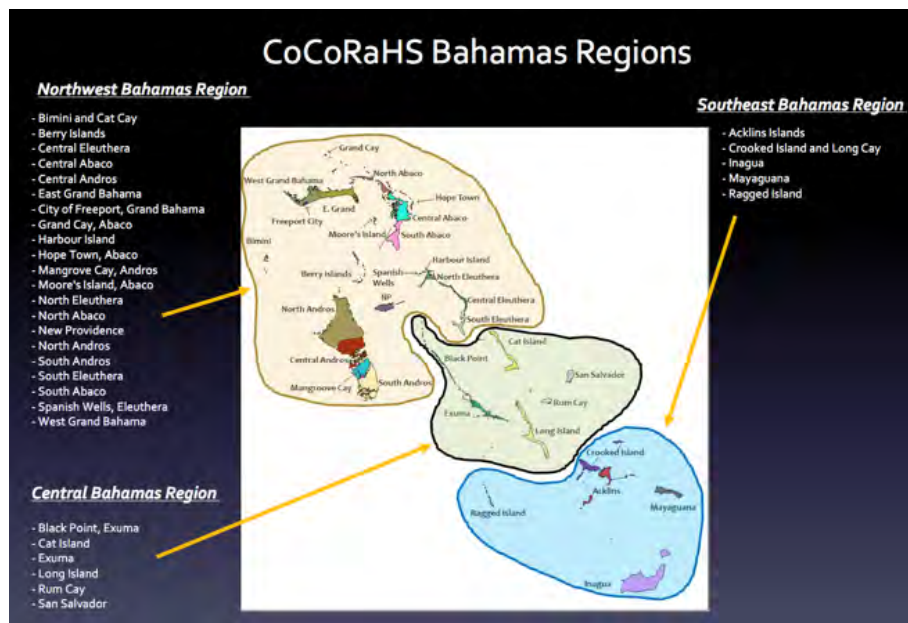

Figure 4. CoCoRaHS Bahamas Regions.

Implementation of the Bahamas Network:

The Bahamas CoCoRaHS Volunteer Rainfall Network began with numerous conference calls between the Bahamas Department of Meteorology, CoCoRaHS, the United States' National Oceanic and Atmospheric Administration (NOAA) and Thomas Peterson, President, World Meteorological Organization (WMO) Commission for Climatology. These took place during the autumn of 2015. Logistics on the division of the archipelago into coordinated regions (Figure 4), who would oversee the regions, the mapping of the Bahamas and potential naming of stations were discussed. Plans for a “Bahamas” Rainfall Network page incorporated into the CoCoRaHS webpage were also developed (Figure 5). During the process of engaging with stakeholders prior to island visits, the Water and Sewerage Corporation of the Bahamas prepared a list of over 30 locations where they would like to take Bahamas precipitation measurements (Figure 6).



Figure 5. The CoCoRaHS Bahamas Webpage.

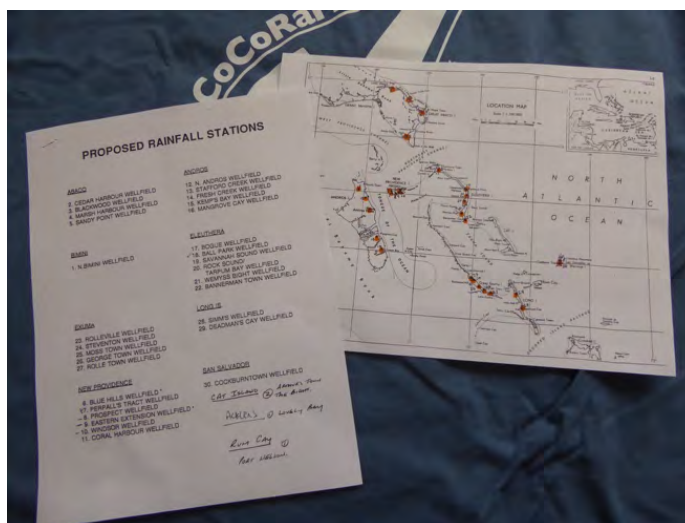

Figure 6. Proposed CoCoRaHS stations.

Efforts were made for the Bahamas Department of Meteorology to clearly know that although CoCoRaHS is collaborating in this effort (providing IT infrastructure, training, etc.), Bahamas CoCoRaHS is their network. We were assured of this understanding, as they described it as such routinely to their stakeholders on our subsequent visits.

In early 2016 plans were made for an orientation site visit to the Bahamas Department of Meteorology for staff training and future development of more Bahamas-centric web materials. Travel to the islands was provided by funds from the Global Climate Observing System (GCOS). It was learned that rainfall measurements were few and far between with only six automated airport weather stations (AWOS) measuring throughout the country. Thus the need for more precipitation information was brought to light, especially in such a climate characterized by convective precipitation where rainfall can be intense and amounts can vary significantly over very short distances.

Early March began with a visit to the Bahamas by CoCoRaHS National Coordinator and Lead, WMO Commission for Climatology Rapporteurs on Volunteer Observing Networks, Henry Reges (CoCoRaHS U.S. National Coordinator) along with Thomas Peterson (WMO). There they met with Bahamas Department of Meteorology staff for training and orientation, including Trevor Basden, the PR and director. A meeting was also held at the headquarters of the Bahamas National Emergency Management Agency (NEMA) (Figure 7) to explain the benefits of a greater density of rainfall observations.



Figure 7. Bahamas National Emergency Management Agency (NEMA).

Three trips were taken that week with Bahamas Department of Meteorology staff, one to Abaco Island, another to Eleuthera Island and finally to Grand Bahama Island and the city of Freeport (Figure 8). During these island trips, introductions were made and presentations regarding the network were given to island administrators and other civic leaders (Figure 9). One Freeport talk was to the Grand Bahama Disaster Consultative Committee with twenty-seven people in attendance (Figure 10). On each of these islands, rain gauges were deployed and the volunteers were instructed on how to measure and record the precipitation amounts. By late March 2016 ten gauges had been set up and observers began measuring precipitation.



Figure 8. Bahamas Department of Meteorology staff, Gregory Gibson, Godfrey Burnside and Byron Bain.



Figure 9. Eleuthera Island administrator and civic leaders.



Figure 10. Grand Bahama Disaster Consultative Committee presentation in Freeport, Grand Bahama Island.

April and May became a time to continue development of the CoCoRaHS Bahamas Website, as well as refine and customize our training materials (Figure 11) now that we had been to the country and had seen what the needs were. We found that there is nothing like visiting a location first-hand to get a better background on how to meet these needs.



CoCoRaHS Bahamas Training Slide-Show
Click below to download as PDF.



 PDF

Figure 11. CoCoRaHS Bahamas training materials available on the Web.

Late May ended with a solo trip for Henry Reges to officially launch the network and to visit and train additional volunteer observers on four islands with colleagues from the Bahamas Department of Meteorology. This was done prior to the official start of the 2016 Atlantic Hurricane season 1 June. Three island visits included trainings with administrators on Northern Andros Island (the agricultural island) home of the Bahamas Agricultural and Marine Science Institute (Figure 12), Exuma Island where meetings also included attendees from the Bahamas Department of Water and Sewage, and finally Long Island where it was evident in talking with administrators that rainfall data was desperately needed after the prior year's lashing by Hurricane Joaquin. Finally, time was spent in Nassau with officials at an island-wide NEMA meeting where the Bahamas network was officially launched. By the first week of hurricane season, numerous observers had signed up and were reporting.



Figure 12. Bahamas Agricultural and Marine Science Institute, Morgan's Bluff, Exuma Island.

A third recruiting trip was held in August to the Southern Islands of the Bahamas by members of the Bahamas Met Service staff, adding new stations on the islands of Mayaguana and Inagua. This helped cover the archipelago from north to south.

How many stations will the Bahamas eventually need? Mr. Basden performed an analysis using Thiessen polygons and determined 205 stations would be an appropriate number once the network was more established throughout the islands.

Basic Requirements for Observers:

As the stations were set up throughout the islands, seven basic requirements for observers were presented:

- Obtain a 10.2cm (4") diameter plastic rain gauge (all observers use same gauge) These were provided to each Bahamian observer through NOAA donated gauges (in the United States, gauges are purchased by observers).
- Sign up on-line. Station name identification and location are then assigned.
- Have a means of communication for transmitting the data: mobile phone or computer.
- View the training materials on-line or attend a training session.
- Be reliable, do your best to take observations on a daily basis (multiday if missed).
- Report zero when no precipitation has fallen (zeroes are important!).
- Have fun and enjoy what you are doing!

Initial CoCoRaHS Bahamas Rainy Season Efforts (May-September 2016):

The Bahamas rainy season usually spans from May through October as the surrounding ocean and land heats up producing almost daily convective showers. These are augmented by the occasional easterly tropical wave and in some years by tropical storms and hurricanes. 2016 saw typical convective storms dot the islands, several tropical waves pass through and in early October a category four hurricane named Matthew moved through the islands from south to north. It directly hit Grand Bahama Island, temporarily knocking out communications and rainfall observations (Figure 13).

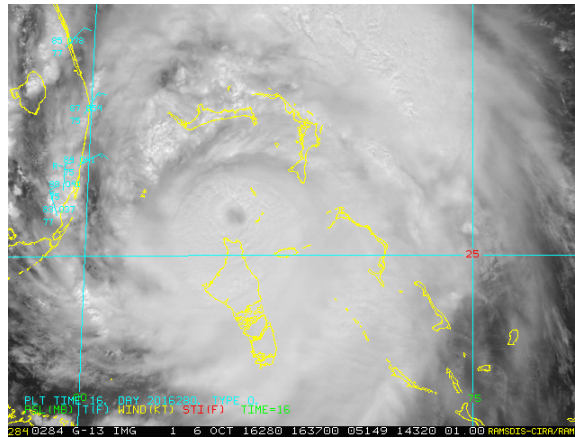

Figure 13. Category 4 Hurricane Matthew moving through the Northern Bahama Islands

May 2016 saw an average of nine stations regularly reporting. These were on the northernmost islands of Grand Bahama, Andros, New Providence, Eleuthera, Exuma and Long Island, with a concentration of five stations in the city of Nassau. Several observers had taken advantage of the CoCoRaHS app for mobile devices for transmitting their reports (Figure 14). Eleven days saw no precipitation, but that changed the last two weeks of the month, when at least one island on any given day experienced rainfall.

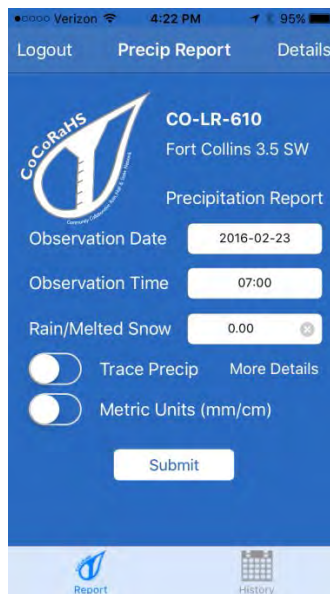

Figure 14. CoCoRaHS Mobile app

The month of June saw a growth of regularly reporting stations to an average of eleven per day. Several days during wet periods had seventeen stations reporting. Five days had daily amounts in excess of 50.8 mm (two inches) with a 65.5mm (2.58") report on 21 June in central Nassau (Figure 15). This stood out among the six stations reporting on the island.

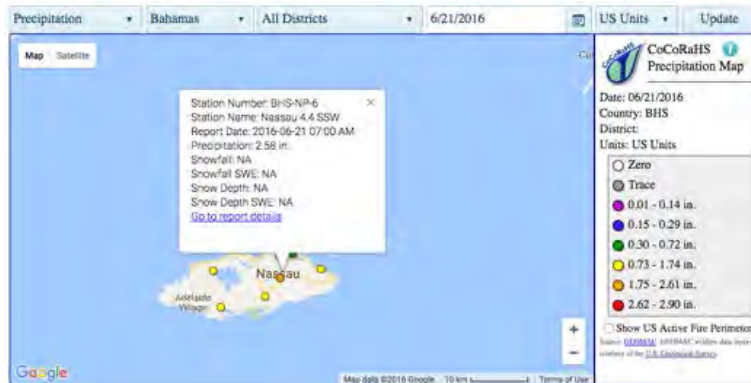

Figure 15. Heaviest daily rainfall of the month reported in central Nassau, 21 June.

July, the heart of the rainy season, averaged fourteen stations reporting daily. There was only one dry day throughout the islands, 9 July. 71.1mm (2.80”) fell on 23 July at a station in Georgetown on the Island of Exuma. Most locations received between 2.0-10.0mm daily.

August, lived up to its reputation as a wet convective month with four days seeing reports over 50.8mm (2.00”). An average of sixteen stations reported daily. The only dry day across the islands during the month was 8 August. The heaviest rain fell in central Nassau 67.6mm (2.66”) on 30 August, the same station with the heaviest precipitation day in June. Could central Nassau be a wet spot on the Island? We will know more as stations establish longer term reporting records.

Finally, the month of September’s daily reports averaged around twenty as the month drew to a close (Figure 16). Only two days had all stations reporting zero. Eleven days saw at least 25.4mm (1.00”) falling somewhere throughout the islands, with four days topping 51.6mm (2.03”). Five new stations on Grand Bahama Island provided very helpful data during the final days of the month with the heaviest daily amount falling on the city of Freeport, 61.7mm (2.43”) on 28 September.

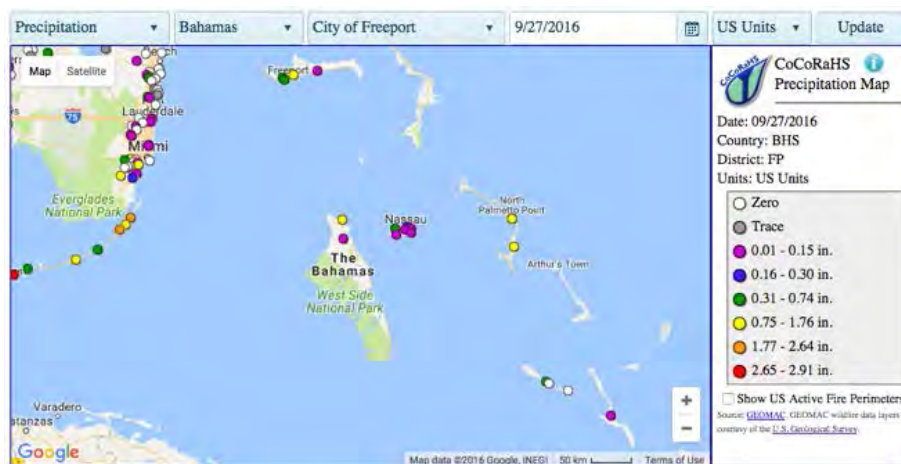

Figure 16. An increase in Bahamas observers by the end of September 2016.

In summary the number of daily reporting stations increased slowly, but steadily from nine to twenty during the five-month period. By 30 September that number had even reached twenty-two with a total of 33 different stations reporting at least a few times during the summer. As seen in other countries initial growth can be often be slow. As we added individual states to our network in the United States, growth was sporadic at first, but over the long run the number of observers steadily increased. We hope the same for the Bahamas CoCoRaHS Rainfall network in the months ahead with help from the Bahamas

Department of Meteorology, as they continue their recruiting efforts. The more involved and enthusiastic the coordinators, the better the chances are for long term growth.

Final Comments:

In the pilot project described here, a modest network of low-cost rain gauges was deployed successfully in a matter of a few months. So far, good quality data collection has been achieved and the network continues to collect data (as of this report date). Gauge comparison results suggest that CoCoRaHS precipitation data collection is of high quality and compares well with manually collected data from the Bahamas Meteorological Service. To assure quality data going forward, a quality control process is highly recommended to check, verify and provide follow-up in the cases of outlier data as seen in the Freeport example above.

CoCoRaHS or networks like it, have the potential to help supplement the missing gaps of observations in many countries at a very economical cost when compared to expensive automated stations which require continual maintenance.

We believe that a well-coordinated, volunteer network using simple collection devices can yield great benefits. Networks like CoCoRaHS already have the training, as well as the experience in putting such a network in place. They are currently developing infrastructure to add new countries. Further discussions are most welcomed to learn about how National Meteorological and Hydrological Services (NMHS's) can join the CoCoRaHS network.

Publications:

Reges, H., N. Doesken, J. Turner, N. Newman, A. Bergantino, and Z. Schwalbe, 2016: COCORAHs: The evolution and accomplishments of a volunteer rain gauge network. Bull. Amer. Meteor. Soc. doi:10.1175/BAMS-D-14-00213.1, in press.

Images:

Figures 1-12, 14-16: Image/Photo credits - CoCoRaHS
Figure 13: Image credit – RAMSDIS CIRA/RAMM

PROJECT TITLE: Explicit Forecasts of Recurrence Intervals for Rainfall: Evaluation and Implementation Using Convection-allowing Models

PRINCIPAL INVESTIGATOR: Russ Schumacher, CSU

RESEARCH TEAM: Greg Herman

NOAA TECHNICAL CONTACT: Gary Wick, ESRL

NOAA RESEARCH TEAM: Kelly Mahoney, CIRES (collaborator), Gary Wick, ESRL (collaborator), Rob Cifelli, ESRL (collaborator)

FISCAL YEAR FUNDING: \$0

PROJECT:

Progress Report Project Period – 07/01/2014 – 06/30/2015
Entire Project Period – 07/01/2014 – 06/30/2015

PROJECT ACCOMPLISHMENTS:

1--General Description of Progress

The primary objective of this project was to evaluate high-resolution numerical model forecasts of heavy precipitation by comparing the quantitative precipitation forecast (QPF) values against observed historical recurrence intervals for precipitation (i.e., the “100-year rain event”, etc.) This method offers additional insight into the magnitude of the rainfall being predicted by the model, heightens situational awareness for forecasters, and allows for the identification of model biases. Graduate student Greg Herman, under the supervision of PI Russ Schumacher, made substantial progress on this project in several areas. He has analyzed forecast output from several convection-allowing numerical models, namely the NAM 4-km nest; the CSU 4-km WRF; the NSSL 4-km WRF; and the High Resolution Rapid Refresh (HRRR) over the time periods that each is available. This analysis has revealed a variety of characteristics of these different models as they relate to observations, and as they compare to one another.

Real-time analysis and monitoring of high-resolution QPF has been evaluated during the Hydrometeorology Testbed (HMT) Flash Flood and Intense Rainfall (FFaIR) experiments in 2014 and 2015, and some of the ideas and findings of our study are being tested in operational environments. Greg Herman has presented his findings at two national conferences and is nearing completion of his MS thesis research that was supported by this project. We are seeking avenues for continued collaboration with WPC to extend this research and evaluate its transition to operations.

2--Transition to Operations

a--Summary of testbed-related activities and outcomes

Under the support of this project, we developed a web interface for comparing convection-allowing model QPFs against the historical Atlas 14 (or other atlas as appropriate) recurrence intervals (http://schumacher.atmos.colostate.edu/qpf_monitor/; screenshot below). In the 2014 FFaIR testbed experiment, this website was informally evaluated along several other methods for diagnosing model QPFs for extreme rainfall. Then, over the course of the next year, we worked with WPC and HMT staff to incorporate this method into the workstation environment at WPC, and then the method was evaluated more robustly during the 2015 FFaIR.

b--What was transitioned?

The primary product that was transitioned was a set of merged GRIB2 files containing the most up-to-date recurrence interval information across the CONUS (Atlas 14 where available, and older atlases where the recurrence intervals have not yet been updated). WPC and HMT staff then incorporated this into the workstation environment and developed code to compare real-time QPFs against these recurrence intervals, and generate graphics indicating locations where models were predicting rainfall amounts to exceed them.

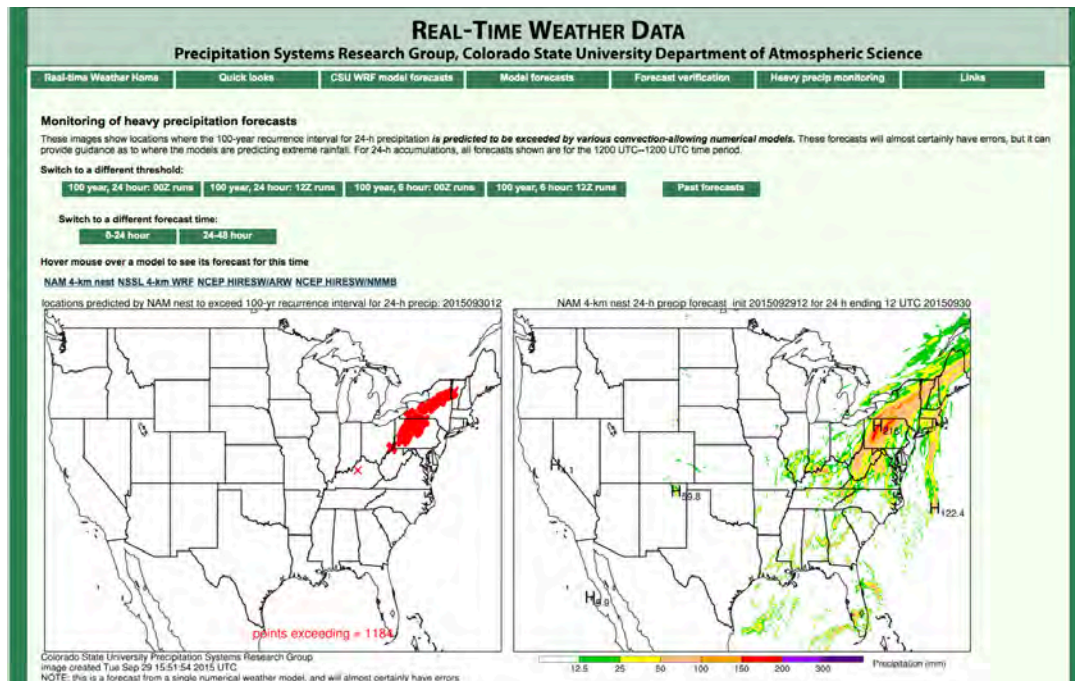

Figure 1. Screenshot of real-time QPF monitoring, showing NAM nest forecast of extreme precipitation in the northeast US for the 24-h period ending 30 September 2015.

3--TRL* current vs. start of project

At the beginning of the project, this work was at TRL 4 (Component/subsystem validation in laboratory environment), and at the end of the project it was at TRL 6 (System/subsystem model or prototyping demonstration in a relevant end-to-end environment), with the relevant environment being the FFaIR experiment. It is nearing TRL 7, as WPC staff are beginning to evaluate this method in the operational environment at their MetWatch desk.

4--Lessons learned

The primary lesson during this work was to ensure that data files are generated in formats that are compatible with operational systems (which, in this case, is primarily GRIB2 format). Often in the university/research environment, non-GRIB formats are used, but it was important to develop or convert output in GRIB format as well.

5--Next steps – future plans

As mentioned above, WPC is currently evaluating this method in the operational environment at their MetWatch desk. If it is found to be a useful method for situational awareness for operational forecasters in their forecasts of extreme precipitation, it may be fully transitioned into operations. We have been seeking additional funding to continue collaborating with WPC to extend and apply additional research findings in the operational environment, but our proposals have thus far been unsuccessful.

6--Milestones

a--Completed

The milestones for this project listed in the original proposal were:

- Prepare basic real-time maps for evaluation at the WPC/HMT FFaIR experiment
- Participate in FFaIR and evaluate these approaches with other researchers and forecasters

- Conduct evaluation of model forecasts from 2012-2013 (and possibly 2014 if time allows).
- Develop real-time analysis and visualization of model forecasts
- Summarize results into a final report and possibly, depending on the results, a peer-reviewed publication.

All of these milestones have been completed, with the exception of the last one (peer-reviewed publication), which is currently being prepared for submission.

a--Not completed

As mentioned above, the only milestone not yet completed is the publication of a peer-reviewed manuscript, and that work is still in progress. Greg Herman is nearing completion of his MS thesis and that will be revised and edited into a journal manuscript within the next 3-6 months.

Publications

Greg Herman is nearing completion of his MS thesis and that will be revised and edited into a journal manuscript within the next 3-6 months (in progress)

Other publications/presentations

“Generating Skillful and Reliable Probabilistic Forecasts for Locally Extreme Rainfall”, 27th Conference On Weather Analysis And Forecasting/23rd Conference On Numerical Weather Prediction, Chicago, IL, July 2015 (oral presentation by Greg Herman, available online at: <https://ams.confex.com/ams/27WAF23NWP/webprogram/Paper273812.html>)

“Forecast Improvement of Locally Heavy Rainfall Events Through Diagnosis and Examination of Model Precipitation Climatologies,” Special Symposium on Model Postprocessing and Downscaling, 95th AMS Annual Meeting, Phoenix, AZ, January 2015 (poster presentation by Greg Herman)

DATA DISTRIBUTION

Research focusing on identifying effective and efficient methods of quickly distributing and displaying very large sets of environmental and model data using data networks, using web map services, data compression algorithms, and other techniques.

PROJECT TITLE: CIRA Research Collaborations with the NWS Meteorological Development lab on Virtual Laboratory, Innovation Web Portal, Impacts Catalog, Autonowcaster and AWIPS II Projects

PRINCIPAL INVESTIGATOR: Sher Schranz

RESEARCH TEAM: Kenneth Sperow, John Crockett, Michael Giebler, Jason Levit, Jason Burks, Dan Gilmore, David Miller, Michael Coulman, Geoff Wagner, Paul Roebber

NOAA TECHNICAL CONTACT: Stephan Smith (NOAA/NWS/OSTI/MDL)

NOAA RESEARCH TEAM: NOAA/NWS/OSTI/MDL: Mamoudou Ba, Lingyan Xin, Matthew Davis, John Schattel, Michael Churma, Tom Filiaggi, Matthew Peroutka, David Ruth, Steve Olsen, Kenneth Howard (NSSL), Ryan Solomon (NOAA/NWS/AWC)

FISCAL YEAR FUNDING: \$1,747,406

PROJECT OBJECTIVES:



Virtual Lab (VLab) <https://mlab.ncep.noaa.gov>:

The NWS has created a service and IT framework that enables NOAA, in particular the NWS, and its partners to share ideas, collaborate, engage in software development, and conduct applied research from anywhere. The project's objectives are the following:

- 1--Reduce the time and cost of transitions of NWS field innovations to enterprise operations;
- 2--Minimize redundancy and leverage complementary, yet physically separated, skill sets;
- 3--Forge scientific and technical solutions based on a broad, diverse consensus; and
- 4--Promote a NOAA/NWS culture based on collaboration and trust.

AWIPS II:

AWIPS is an open source, service oriented architecture (SOA) that the National Weather Service uses for interrogation/display, forecast preparation and dissemination of weather data and products.

MDL and CIRA provide technical leadership to the AWIPS Program Office. Additionally, we develop new AWIPS applications and enhance existing applications. AWIPS II uses many technologies (JAVA, Camel, Hibernate, Python, JMS, JMX, etc.) that are new to the MDL and the NWS. In order for the MDL to be in a position to add value, they need people who have a working understanding of these technologies. Also MDL needs to be able to provide technical assistance in the form of software development expertise to assist in the shaping of the evolving AWIPS architecture.

AutoNowCaster (ANC):

Originally developed by the Research Applications Laboratory at the National Center for Atmospheric Research, ANC nowcasts convective initiation. The project's objectives are the following:

- 1--Transition ANC to operations so that its nowcasts of convective initiation are available to interested entities, and provide third-tier support for it in operations
- 2--Contribute to experiments designed to improve, better understand, or showcase ANC, and contribute to any associated publications or presentations
- 3--Where necessary or possible, correct or optimize ANC's software and streamline its configuration
- 4--Develop a more complete understanding of ANC's architecture and configuration, and document that understanding

Impacts Catalog / IRIS / iNWS / HazCollect Extended:

The National Weather Service's Weather-Ready Nation Roadmap calls out the creation of a national Impacts Catalog, a system whereby the NWS can improve its Impact-based Decision Support Services to its core partners by providing those partners information regarding the impacts which relevant meteorological variables will have on those partners' operations. The project's objectives are the following:

- 1--Provide leadership and technical expertise
- 2--Contribute to the engineering of the Impacts Catalog's software, including that of its framework system, IRIS, and its corollary systems, iNWS and HazCollectExtended

Weather Information Statistical Post Processing System (WISPS):

WISPS is a new, community-based, statistical post-processing software system being designed by MDL. The scientific algorithms and workflow ideas of the current operational Model Output Statistics system, MOS-2000, will be the first statistical post-processing methods incorporated into WISPS. The WISPS Project is a 3-year effort to develop the framework that will take the inaugural version of WISPS to Technical Readiness Level 9 (i.e., operational implementation on NOAA's Weather and Climate Operational Supercomputing System, WCOSS) for some portion of the NWS' statistical postprocessing mission. The project will emphasize suitability for supercomputer operations, multiple statistical postprocessing methods, data formats that are self-describing and embrace widely-accepted standards, and software systems that are flexible, extensible, and shareable. The project's objectives are the following:

- 1--Co-lead the development of WISPS with a team of experts provided by MDL.
- 2--Lead and oversee the process that gathers and documents requirements for WISPS.
- 3--Lead and oversee the investigation of useful pre-existing technologies that are suitable for WISPS.
- 4--Lead and oversee the design and development of data storage technologies and data modeling strategies for WISPS.

Statistical Post-processing of output from Numerical Weather Prediction (NWP) systems:

It is difficult to overestimate the importance of StatPP guidance created by MDL. This includes output from MDL's signature Model Output Statistics (MOS) technique as well as the National Blend of Models (NBM). Together, they provide a set of next-generation foundational guidance products based on NWS and non-NWS model information. The techniques developed are intended to create an enduring process for the generation of guidance products for lead times extending from hours to two weeks. The project's objectives are the following:

- 1--Work collaboratively and independently with MDL scientists to investigate and develop statistical post-processing and blending techniques for NBM.
- 2--Develop software and leverage existing algorithms that can derive variables needed to support the StatPP needs of the weather enterprise.
- 3--Develop, test, and document computer programs (primarily in Fortran and Python) and scripts necessary for data processing.

- 4--Work collaboratively with MDL scientists as they write documentation, create displays and maps, and prepare presentations.
- 5--Work collaboratively with MDL scientists who are implementing operational software on NOAA's various supercomputing platforms.

MDL Geospatial Data Services/Interactive Map Viewer:

The Meteorological Development Laboratory (MDL) develops and implements techniques that generate products and services that enhance the value of NWS forecast products. Techniques emphasize information on forecast uncertainty that enhance decision making throughout the weather enterprise. Techniques also include data modeling, metadata, and web services that support NOAA's dissemination needs. Prototyping of promising techniques is done to identify those best for implementation. One area of focus includes geospatial data services that provide maximum flexibility for use by public customers and partners. Once developed and vigorously tested, these techniques are implemented in software on NWS operational platforms. The project objects are:

- 1--Collaborate with MDL staff to develop and maintain systems to access quality operational and experimental NWS forecasts under two project areas: Modernized Product Generation and Delivery/Information Dissemination Program (IDP) and interactive Map Viewer.
- 2--Collaborate with MDL's staff to develop and visualize new products for the National Digital Forecast Database (NDFD) and the National Digital Guidance Database (NDGD).
- 3--Coordinate with NWS and non-NWS agencies on forecast guidance issues.

Local Climate Analysis Tool (LCAT):

LCAT is an online, interactive tool that will enable NWS forecasters and other registered users to conduct regional and local climate studies using station and reanalysis gridded data and various statistical techniques for climate analysis. LCAT will provides users with "best practice" climatological analysis techniques, saving time for the user and guaranteeing scientifically sound output. The analysis results could be used for Decision Support Services activities, to guide local decision makers in weather and climate-sensitive actions. LCAT augments current climate reference materials with information pertinent to the local/regional level as they apply to diverse variables appropriate to each locality. The LCAT studies allow users to supplement NOAA NWS climate forecasts with value-added information and increase expertise in impact of climate variability and change at local level. The LCAT outcomes will be also useful for guidance of governmental, economic, and business planning. Project objectives include:

- 1--Provide direction and expertise to develop the existing LCAT program.
- 2--Establish a Science Advisory team to develop environmental intelligence for a range of applications, grid reanalysis capabilities and web interfaces.
- 3--Develop tools and services for LCAT.
 - a--Investigate RESTful API to expand the reach & utility LCAT provides.
 - b--Plan & implement 'sea ice' expansion to LCAT.
- 4--Develop new web interface for LCAT.

Web Services:

The Meteorological Development Laboratory (MDL) continues to lead the way in data modeling and schema development for the International Civil Aviation Organization (ICAO) Weather eXchange Model for the US (IWXXM-US) and U.S Weather eXchange (USWX) model as well as the decoder and encoder software needed for the IWXXM-US and USWX products. MDL is also focused on the creation and modification of metadata records for these gridded and non-gridded weather products using ISO standards 19115-1, 19115-2 and 19139. However, it should be noted that the ISO standards are evolving and newly adopted changes are imminent. More recently, MDL has been brought on the OpenWIS program to provide technological development and enhancements to the OpenWIS web services software package. Project objectives include:

- 1--Development of the aviation-focused gridded and non-gridded products metadata records.
- 2--Translation of these metadata records into any newly adopted ISO standards (e.g. ISO 19115-3).
- 3--Evaluation of discovery service options that can be used by IDP.

- 4--Software development for non-gridded product decoders and encoders for IDP.
- 5--Development and implementation of OpenWIS software improvements and enhancements in collaboration with partners, including NWS, FAA, DoD, NCAR and others.

PROJECT ACCOMPLISHMENTS:

VLab:

Ken Sperow continues as the VLab technical lead, as well as the technical lead of the Virtual Lab Support Team (VLST). This team currently consists of 12 members to whom Ken provides support and training. Ken is not only the technical lead but also the deployment manager for VLab, overseeing and conducting all upgrades, security and feature updates within VLab. Under Ken Sperow and Stephan Smith's (the NOAA PI) leadership, the VLab continued to grow in importance and visibility within the NWS and NOAA again this year. The VLab is an essential and required component in the transition of research to operations for the NWS AWIPS. All AWIPS II development organizations must use VLab to check in, review, and verify AWIPS II code before it is included in the operational baseline.

VLDS Provides web-based services to help manage projects via issue tracking, source control sharing, code review, and continuous integration, VLab Development Services (VLDS) has grown by over 100% again this year to support over 400 projects and 2300 developers. Multiple demos and consultations were made to development and operations groups covering VLab's capabilities and how they can be leveraged to address the group's needs. Additionally, staff worked with the NOAA CIO and Fisheries to allow the use of GitHub.com in combination with VLab.

Ken Sperow is the VLab expert, which includes providing guidance on Gerrit, Jenkins, Liferay, and Redmine, but also git expertise. A proposal has been submitted for NCEP EMC to transition all of the numerical modeling code to VLab, switching from svn to git.

Jason Burks developed and implemented the Consolidate Reference Portlet for VLab. The Consolidated Reference portlet enables users of VLab to easily enable material in VLab to be found by users in AWIPS looking for reference material on meteorological products. The performance of each component was analyzed and re-worked to tune the system to operate more optimally. Jason also implemented Google Single Sign On within two components of VLab to make it easier for users to access VLab. The addition of this to VLab allows users who are already logged into Google to login to VLab using their existing login with Google.

Michael Giebler provided excellent support and development to the VLab this year. Additional enhancements were made to the NOAA Projects Registry. The Project Registry provides an interface for all of NOAA to enter project information into the VLab, enabling tracking of projects' transitions from research and development to operations, commercialization, and other uses. To date information for 560 projects have been entered into the repository. The NOAA Projects Registry is being considered as a replacement for the PDMS database which tracks additional metrics such as project milestones and project funding.

The Ideas Marketplace has been moved to VLab's production servers. The Ideas Marketplace provides a mechanism for VLab users to share ideas. Each idea has its own forum area providing a place for questions and answers about the idea along with general discussion. The Ideas Marketplace can be used separately in individual VLab communities and is being considered as a possible solution for Weather Services Innovation Review Board.

Customer support and guidance is provided on the many facets of VLab. This includes setting up new communities and projects within VLab, import legacy data such as project management issues and code repositories, consultations with individuals and groups that provide guidance and assistance.

AWIPS II:

Ken Sperow assisted NWS Systems Engineering Center management with the high-level design of AWIPS II configuration management and governance in addition to defining tasks necessary to improve development of AWIPS II. Technical assistance is provided to the AWIPS II community on building and deploying AWIPS II and assistance to Joe Zajic with the testing of Python scripts written by Joe that simplified development of A2. Ken provides AWIPS II support to MDL developers to install new releases of the AWIPS II software on the system for knowledge transfer and development activities. The AWIPS Program requested a survey of several projects inside and outside of AWIPS that have overlaps in order to find areas that the projects could benefit from synergies. A report was delivered and briefed to the team that oversees AWIPS development.

Ken also worked with the AWIPS Program Office (APO) to provide access to VLab from the AWIPS network. Staff also worked with the NWS field and the APO to migrate the Software Collaboration Portal (SCP), which hosts all AWIPS local applications, to VLab. The SCP was hosted in Trac on a server that needed to be decommissioned.

Jason Burks participated in several software design reviews for other groups developing for the AWIPS architecture at the request of the team that oversees AWIPS development. An AWIPS Plugin to enable product based informational resources to be easily accessible by AWIPS end-users was delivered in April 2016. The plugin utilizes VLab to host the material. Jason also developed a build tool that could be used by AWIPS development organizations to build the AWIPS II system. The tool allows users to start with only the tool which downloads, configures, and builds the entire architecture.

ANC:

John Crockett continues to support the day-to-day running of ANC at the MDL, as well as maintain and update all of the documentation related to ANC. He continues to modify ANC applications in order to reduce overall CPU and disk usage, finding and fixing software bugs as needed.

Along with NSSL team members, John completed the process of transitioning ANC to operations as a subsystem of the Multi-Radar/Multi-Sensor system at the National Centers for Environmental Prediction. As part of this work, he also transitioned ANC to use Rapid Refresh Version 3 grids and communicated to Aviation Weather Center team members how to ingest ANC's operational grids.

John and Paul Roebber began a research project to investigate how ANC's methodology for weighting its interest fields can be made adaptive. John produced and provided the project's input data. Paul used these data to define regimes (based on the concept of Self-Organizing Maps), then developed four training protocols with which to investigate the data and the regimes, and began developing the software needed to effect those protocols.

CIRA Staff again assisted Taiwan's Central Weather Bureau (CWB) with its understanding and use of ANC. As part of this work, John Crockett traveled to Taipei, Taiwan, where he reconfigured the CWB's MDL-ANC system to ingest the composite radar reflectivity grid output by the CWB's Quantitative Precipitation Estimation and Segregation Using Multiple Sensors system, reconfigured the CWB's MDL-ANC system to ingest satellite data in a way which makes it more certain that those data are available. He also fixed misconfigurations on both the CWB's operational TANC system and its MDL-ANC system. He answered any and all questions as they arose, and provided to the CWB's ANC team a list of recommendations for them to consider with respect to their use of ANC. Upon his return, John investigated and fixed problems remotely as the need arose.

John Crockett, with Mamoudou Ba, Lingyan Xin, and Stephan Smith, wrote and submitted the paper Evaluation of NCAR's AutoNowCaster for Operational Application within the National Weather Service to the journal Weather and Forecasting. John also created the presentation Evaluation of NCAR's AutoNowCaster for Operational Application within the National Weather Service, and which he gave at the June, 2016 VLab Forum. He also presented a poster at the 2017 AMS Annual Meeting, Evaluation of NCAR's AutoNowCaster for Operational Application within the National Weather Service.

Impacts Catalog / IRIS / iNWS / HazCollect Extended:

As Deputy Technical Lead of the project, John Crockett, helped diagnose problems with the operational system and coordinated the mitigation efforts with Matthew Davis, the federal Technical Lead. John maintained the primary responsibility for the engineering and further development of the system's contact management application. He began to take on responsibility for the (re-)engineering and further development of the system's data ingest applications. John contributed to the design and development of the software which will distribute Storm Surge Watch/Warning data both to NIDS and to the Wireless Emergency Alerts system.

John presented a project-related poster at the 2017 Annual Meeting of the American Meteorological Society. He also participated in a three-day project Design and Development Conference at the NWS Training Center in Boulder, CO. He participated in, and sometimes led, weekly Development Team teleconferences and began drafting project-wide, systems level documentation.

John Crockett continued to function as a manager of the Virtual Laboratory's Impacts Catalog Community. This included writing blog posts so that the community was kept abreast of the project's status. He also continued to function as a member of the project's Integrated Working Team.

WISPS:

Jason Levit continued working as the co-lead for the WISPS project. During the past year, Jason completed a simple prototype of the main WISPS statistical post-processing algorithm using python and NetCDF. This included investigating NetCDF and HDF storage types, coding the forward-selection linear regression algorithm into python, and testing on the RDHPCS.

Jason contributed to building a community-based software system through outreach to partners. Jason accompanied MDL personnel on outreach trips to CMC in Montreal, UKMet in Exeter, UK and gave a presentation on WISPS at the National Weather Association and American Meteorological Society Annual Meetings.

Jason developed initial plans for full conversion of MOS-2000 algorithms and ideas into the WISPS infrastructure, and assisted in managing the work of all employees tasked with implementing the project and participated in MDL quarterly project reviews. Jason created the WISPS technical and scientific implementation plan, and published it to the WISPS VLab site. The document serves as a roadmap to guide development efforts. He trained new employees assigned to the project on the use of MOS-2000 workflow and data, and worked with employees in incorporating initial MOS-2000 algorithms in the WISPS software infrastructure. He also rigorously tested prototype WISPS software as developed, including nearly completed portions used for the pre-processing of METAR, marine, and GRIB GFS data.

Through updates to documentation and overall site look and feel, Jason maintained both the external and internal WISPS site on NOAA's VLab, He maintained the WISPS git code repository on NOAA's VLab, and set-up WISPS code projects. Jason also managed the overall WISPS coding effort through continual testing and refinement on the NOAA RDHPCS, and through continual code reviews via Gerrit/Jenkins. He assisted in the development of the NWS code registry web site, through collaboration with UKMET and initial planning meetings. This included an effort to test the registry by creating test data and implementing via the web site.

Statistical Post-processing of output from Numerical Weather Prediction (NWP) systems:

Geoff Wagner started working for CIRA in early January 2017 on this project. To begin, he evaluated the feasibility of using Coastal Relief Model (CRM) data to address concerns expressed by WFOs regarding coastal areas in the unified terrain and land/water datasets, which are to be incorporated through MDL applications (National Blend of Models, Gridded MOS, EKDMOS, and Gridded LAMP), the RTMA and URMA analyses, and AWIPS. Geoff also investigated techniques to accurately mosaic the datasets of differing resolutions and coordinate systems together in ArcGIS. The final version is nearing completion and will be incorporated in future versions of NBM, GMOS, EKDMOS, Gridded LAMP, RTMA, URMA, and AWIPS.

Goeff worked to convert Gridded MOS updates to run in MDL/NCO's operational framework. The scope of this work is to add 10,000+ mesonet forecasts for temperature, dew point temperature, daytime maximum temperature, nighttime minimum temperature, and wind speed to the CONUS GMOS analysis. This package also carries updated software, and adjustments to two other NBM-input elements, Sky Cover and Wind Gust. All portions of this work are scheduled for delivery to the MDL operations team in mid-March for a July implementation.

MDL Geospatial Data Services/Interactive Map Viewer:

David Miller started working for CIRA in early December 2016 on this project. Since then, David has developed a screen capture functionality for the National Blended Model (NBM) web multimap viewer (which includes NDFD and NDGD image/data overlays). This functionality didn't exist previously due to limitations inherent with the mapping software. He discovered that a screen capture Javascript library had recently been updated to overcome those limitations. This functionality will be incorporated in a future release of MDL NDFD map viewer.

David solved an issue with the NBM Alaska grid overlays where they were displaced significantly to the southeast. He discovered the Alaska grid resolution had increased from 6km to 3km and this change altered the geo-referencing data used in transforming the overlays from Polar Stereographic to Spherical Mercator. Therefore, he provided updated geo-reference information for overlay transformation scripts and NBM map viewer Javascript code.

He also corrected wind barb display on the NBM map viewer so that: 1) the beginning of the barb staff starts at the location point, 2) the barbs change size according to the map zoom level and, 3) the modified PNG images of the barb images were correct (previously had drawing gaps) and also displayed up to 150 knots.

David corrected a bug in the MDL NDFD map viewer code where the mouse over values in some cases were not indicating if they went beyond the established range. Discovered a logic issue where a maximum grid value was being compared to a rounded up maximum display value and never indicated that the value was at or beyond the established range. He also improved display reliability and speed of static map overlays of state, counties, and Weather Forecast Office outlines on the NBM viewer by using a local Mapserver Web Map Service (WMS) versus using the one used by the NDFD map viewer. When the NDFD map viewer WMS was unavailable, these overlays would not display and that problem could not be resolved by MDL staff. The use of local Mapserver WMS instead allowed for quicker resolution by MDL should it go down.

David provided a proof-of-concept display of Mean Absolute Error (MAE) data in Keyhole Markup Language (KML) file format for possible inclusion in a future NBM viewer release. Also, David assisted a NOAA Center for Weather and Climate Prediction (NCWCP) employee by describing how to create an overlay layer using the NDFD map viewer WMS to display the NDFD weather element on a web map created with Leaflet web mapping software. He then developed a test page with Leaflet using the NDFD map viewer WMS to demonstrate this capability.

LCAT:

Michael Coulman started working for CIRA in January 2017. Michael has focused on developing tools and services for LCAT. Specifically, Michael has investigated a RESTful API to expand the reach and utility LCAT provides. He also has planned and begun implementation of the 'sea ice' expansion of LCAT.

IDP Web Services:

Dan Gilmore started working for CIRA in late December 2016. Specifically, Dan started with the creation of translators that decode NWS AIREP and Volcanic Ash text products, and encode those into OGC-compliant XML format. This includes generating the documentation for use by the FAA, as these will ultimately be fed through IDP into the FAA system. This code was written in python. Next, Dan created metadata files describing the G_AIRMET and PIREP NWS text products, also for use by the FAA as well

as for insertion into the NOAA metadata system at data.noaa.gov and the OpenWIS system coming online soon. Finally, he Modified existing webServ project code to translate database search results into OGC-compliant XML format. This code is written in C.

Publications:

Burks, J. and K. Sperow, 2017: AWIPS Integrated Reference System. 33rd Conference on Environmental Information Processing Technologies, Seattle, WA, Amer. Meteor. Soc., 5.4 (Recorded Presentation available at <https://ams.confex.com/ams/97Annual/webprogram/Paper311565.html>)

Levit, J. and M. Peroutka, 2017: The Weather Information Statistical Post-Processing System: A community-based post-processing system. 41st Annual Meeting, Norfolk, VA, National Weather Association, 1100. (Available online at: http://nwas.org/meetings/nwas16/abstracts_html/Other/abstract_2967.html)

Levit, J., M. Peroutka and E. Engle, 2017: The Weather Information Statistical Post-Processing System: A community-based post-processing system. 33rd Conference on Environmental Information Processing Technologies, Seattle, WA, Amer. Meteor. Soc., 2A.5. (Recorded Presentation available at: <https://ams.confex.com/ams/97Annual/webprogram/Paper303904.html>)

PROJECT TITLE: CIRA Support to the JPSS Proving Ground and Risk Reduction Program: Integration of JPSS Experimental Products in AWIPS II through EPDT Code Sprints

PRINCIPAL INVESTIGATOR: Scott Longmore

RESEARCH TEAM: None

NOAA TECHNICAL CONTACT: Satya Kalluri (NOAA/NESDIS) and Ed Mandel (NOAA/NWS)

NOAA RESEARCH TEAM: Debra Molenaar, NOAA/NESDIS/STAR/RAMMB

FISCAL YEAR FUNDING: \$18,000

PROJECT OBJECTIVES:

The Experimental Product Development Team (EPDT) is an AWIPS II developer training and collaboration project which is organized by NASA SPoRT and has been running for the last three years. EPDT brings together developers from various agencies such as NASA, NWS, various cooperative institutes to learn to develop plug-ins for the AWIPS II system. EPDT has helped various groups develop a deep understanding of the AWIPS II architecture and methods to extend it to enable new and innovative data and displays. Part of the learning process within EPDT is to facilitate EPDT groups to work on projects of common interest and to provide the environment and access to knowledge that allows these groups to successfully develop plug-ins for their groups as well as groups such as GOES-R Proving Ground. For the past year CIRA's AWIPS II Team has been working closely with the NASA SPoRT Team by leveraging the EPDT team to develop plug-ins to ingest and create innovative displays of JPSS data. The two teams worked closely with end-users and JPSS to develop high-impact plug-ins to enable the NWS to fully utilize JPSS products within the AWIPS II system.

The main objectives of this project was for EPDT participants to build on experiences gained during the past year and to learn to configure and/or develop additional plug-ins for ingest, model, and display of JPSS data within the AWIPS II system.

PROJECT ACCOMPLISHMENTS

The Fall 2016 AWIPS II introduction class utilizing polar orbiting datasets was held December 7-9, 2016 at CSU/CIRA in Fort Collins, Colorado. The CIRA class had five participants from the National Weather Service and one participant from the University of Alaska:

Craig Searcy, NWS Anchorage, Alaska - craig.searcy@noaa.gov

Jay Cable, GINA, Alaska - jay@alaska.edu

Victor Sardina, PTWC - victor.sardina@noaa.gov

William Paintsil, NWS/SEC/ASDT - william.paintsil@noaa.gov

Jun Wu, NWS/SEC/ASDT - jun.wu@noaa.gov

Daniel Eum, NWS, Pacific Region - daniel.eum@oaa.gov

The AWIPS II Fall 2016 introduction course slides can be found on the Google Drive folder:

<https://drive.google.com/drive/u/0/folders/0BwwuQpP7w6HZSXhCWFc3ODdaOWM>

which presented an AWIPS II overview, configuration, operating, and tutorials for adding three different polar orbiting datasets using various plugins (pointset/netCDF4, regionalSat/netCDF3, McIDAS/Area). An overview of the AWIPS II weather event simulator was also covered. A post-course survey can be found here:

<https://drive.google.com/open?id=0BwwuQpP7w6HZZW5rUGxpVUxiNik>

The AWIPS II intro course materials will be beneficial for future AWIPS II EPDT training.



Figure 1. The Fall 2016 EPDT class participants and CIRA instructors at the front entrance of the CIRA Building in Fort Collins, Colorado, in December 2016.

Publications: None

Presentations: None

PROJECT TITLE: EAR - Flow-following Finite-volume Icosahedral Model (FIM) Data Distribution Project

PRINCIPAL INVESTIGATOR: Sher Schranz

RESEARCH TEAM: Brian Jamison, Ning Wang, Ed Szoke

NOAA TECHNICAL CONTACT: Stanley Benjamin (OAR/ESRL/GSD/ADB Chief)

NOAA RESEARCH TEAM: Jian-Wen Bao (OAR/ESRL/PSD), Mark Govett (OAR/ESRL/GSD/ATO)

FISCAL YEAR FUNDING (EAR Total): \$7,309,853

PROJECT OBJECTIVES:

- 1--Generate graphics of output fields, creation and management of web sites for display of those graphics.
- 2--Create and manage graphics for public displays, including software for automatic real-time updates.

PROJECT ACCOMPLISHMENTS:

A web site for display of FIM model output <http://fim.noaa.gov/FIM/> was updated and currently has 7 separate versions of FIM with up to 63 products available in 21 regions for perusal with 6-hourly forecasts going out to 14 days. Many regions have improved resolution by using direct interpolation from the native icosahedral grid to a 0.125 degree global grid (approximately 14 km grid spacing).

Difference plots are generated and available, as are plots of forecast error. New plots have been added of forecast error from a single run for all of the FIM models. Cross sections are also being generated and are available at <http://fim.noaa.gov/FIMxs/>. Plot loops that show the progression of forecasts from model runs with the same valid time (dProg/dt) can be viewed at <http://fim.noaa.gov/FIMdpdt/>.

A new Alaska domain (Figure 1) and two new Alaskan subdomains were added to the FIM suite of domains. The domain matches the Alaska domain used for the RAP model.

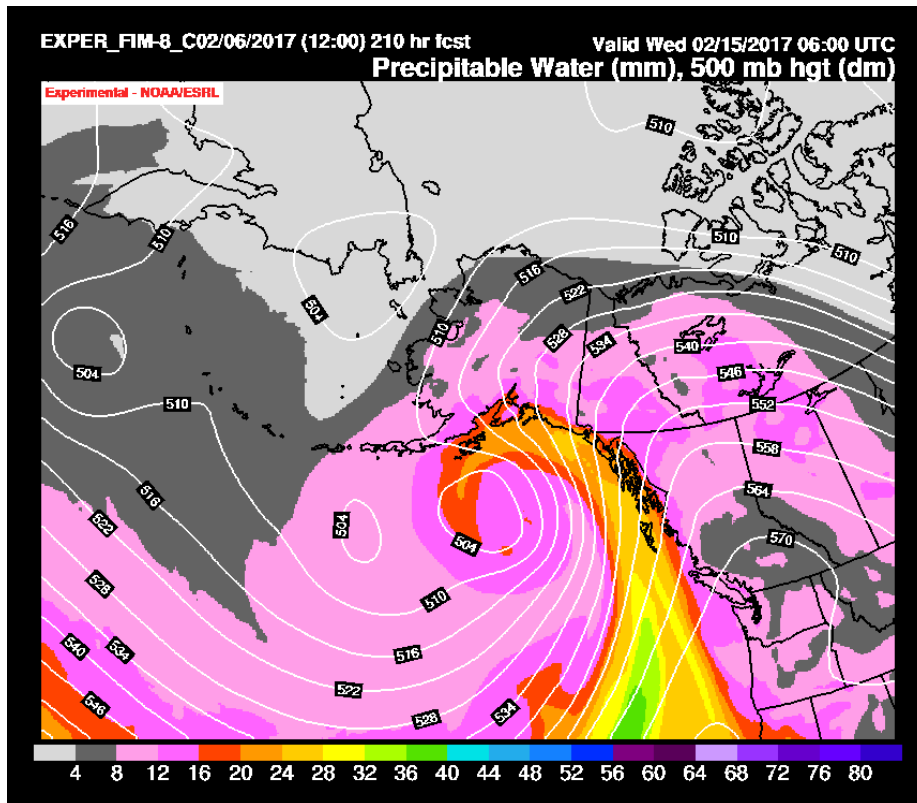

Figure 1. A FIM precipitable water forecast showing the Alaska domain.

A new refined hurricane forecast tracker was implemented for all versions of the FIM, and plotting routines were adjusted to accommodate the new track information.

A dual-monitor hallway display on the second floor of the David Skaggs Research Center (DSRC) displays FIM model graphics for public viewing. Currently, a montage loop of four output fields is displayed and updated regularly.

A large touchscreen kiosk monitor in the second floor atrium area has been updated with added FIM graphic loops of 10-meter wind, precipitation and snowfall. New, larger, and more detailed images were created and are updated specifically for the kiosk.

PROJECT TITLE: EAR – Aviation Weather Forecast Impact and Quality Assessment

PRINCIPAL INVESTIGATOR: Sher Schranz

RESEARCH TEAM: Melissa Petty, Paul Hamer, Michael Turpin, Ken Fenton, Arlene Laing

NOAA TECHNICAL CONTACT: Michael Kraus (OAR/ESRL/GSD/EDS Chief)

NOAA RESEARCH TEAM: CIRES: Matt Wandishin, Geary Layne, Joan Hart, Michael Rabellino, Laura Melling

PROJECT OBJECTIVES:

- 1--Scientific research and quality assessments
- 2--Technology development

PROJECT ACCOMPLISHMENTS:

Scientific Research and Quality Assessments:

Program management, engineering, and scientific support was provided to FIQAS scientific research and quality assessment activities. The primary sponsor for these activities in 2016/17 was the FAA Aviation Weather Research Program (AWRP), for whom FIQAS serves as the Quality Assessment Product Development Team (QA PDT). The role of the QA PDT is to conduct independent evaluations of AWRP products as part of the formal AWRP Research to Operations process.

Accomplishments for FAA AWRP activities include:

Completion of the Evaluation of the Icing Product Alaska - Forecast (IPA-F) Product:

IPA-F is a new forecast of In-flight Icing developed by the In-flight Icing Product Development Team (IFI PDT) within NCAR's Research Applications Laboratory (RAL). The 2016/17 activities supporting the evaluation of this product included completion of analysis of results and reporting of findings. In this assessment, IPA-F was compared to the baseline product currently used by the Alaskan Aviation Weather Unit (AAWU), the Forecast Icing Potential/Forecast Icing Severity (FIP/FIS) products. Overall findings were that IPA-F outperforms FIP/FIS for most scenarios with a limited number of exceptions. Results were presented to AWRP management and the IFI PDT in July 2016, with a written report submitted August 2017. Findings were presented to a Technical Review Panel (TRP) as input to their decision of whether IPA-F should be made available operationally.

Preparation and Implementation for the Evaluation of the Icing Product Alaska - Diagnosis (IPA-D) Product:

IPA-D is a new diagnostic of In-flight Icing developed by the IFI PDT at NCAR/RAL. The 2016/17 activities supporting the evaluation of this product included coordination with the IFI PDT, the Alaska Aviation Weather Unit (AAWU), and AWRP to determine the goals for the assessment, development and finalizing the overall approach for the assessment, implementation of code for the assessment, and preliminary analysis. The verification plan was reviewed with the IFI PDT, the AAWU, and AWRP in Oct 2016. Assessment completion and reporting of results is targeted for July 2016.

Preparation for the Evaluation of the Global Graphical Turbulence Guidance (GTG-G) Product:

The GTG Global turbulence product, developed by NCAR's Turbulence PDT, is a global extension of the GTG forecast system. FIQAS is performing a quality assessment of the product as part of its transition to operations. The 2016/17 activities supporting the evaluation of this product included: coordination with the Turbulence PDT, the Aviation Weather Center (AWC), and AWRP to determine the goals for the assessment, investigation of new global observation sets for potential use in turbulence verification, development of verification techniques, developing and finalizing the overall approach for the assessment, and implementation. Data collection and analysis will begin in May 2017, with a presentation of findings targeted for Dec 2017.

Preparation for the Evaluation of Ensemble Prediction of Oceanic Convective Hazards (EPOCH): The Convective Weather PDT of NCAR/RAL is developing a probabilistic forecast of oceanic convective hazards. The 2016/17 activities supporting the evaluation of this product included coordination with NCAR, AWRP, and AWC to determine the goals for the assessment, investigation of observation sets for use in verification of this oceanic convective product, development of verification techniques, and review of the verification plan for the assessment. Implementation, data collection, data processing, and analysis will occur later in 2017, with reporting of findings planned for early 2018.

Completion of the Impact-based Evaluation of the CDM Convective Forecast Planning Guidance (CCFP): FIQAS performed an evaluation of AWC's CDM Convective Forecast Product (CCFP) to compare the quality of the recently automated version to the human-generated version. The impact-based evaluation entailed use of the Flow Constraint Index (FCI), which translates convective weather information into a measure of airspace constraint, highlighting mode and orientation of convective weather more impactful to operations, as well as high-traffic areas and times of day. The FCI-based approach allows for evaluation of forecast performance for characteristics, regions, and times of day most important to aviation operations. Activities for 2016/17 included completion of data processing, analysis, and reporting of findings. The evaluation period included the full convective seasons (March - Sept) for 2014 and 2015, and a partial season for 2016 (May - July). Findings were presented to stakeholders from FAA, AWC, and NWS ASWSB Sept 2016.

Technology Development:

CIRA was responsible for application development in support of FIQAS activities, including FIQAS assessments as well as the development of technologies for external users. The primary sponsors for these activities in 2016/17 were FAA AWRP, NWS ASWSB, and the NWS Office of Science and Technology Integration (OSTI).

Accomplishments for FAA AWRP activities include:

Verification and Requirements Monitoring Capability (VRMC, Figure 1):

The VRMC is a web-based application developed and maintained by FIQAS, and provides ongoing verification metrics for the operational GTG and CIP/FIP products as well as verification capabilities to support FIQAS assessments performed as part of the operational transition process. Activities for 2016/17 included implementation of an assessment component for IPA-D, which was used to support the analysis of IPA-D results, development of a new User Interface framework for future assessment and monitoring components, and implementation of a monitoring component for GTG3. The GTG3 monitoring component will provide ongoing statistics of GTG3 performance, and was implemented using the new UI framework.

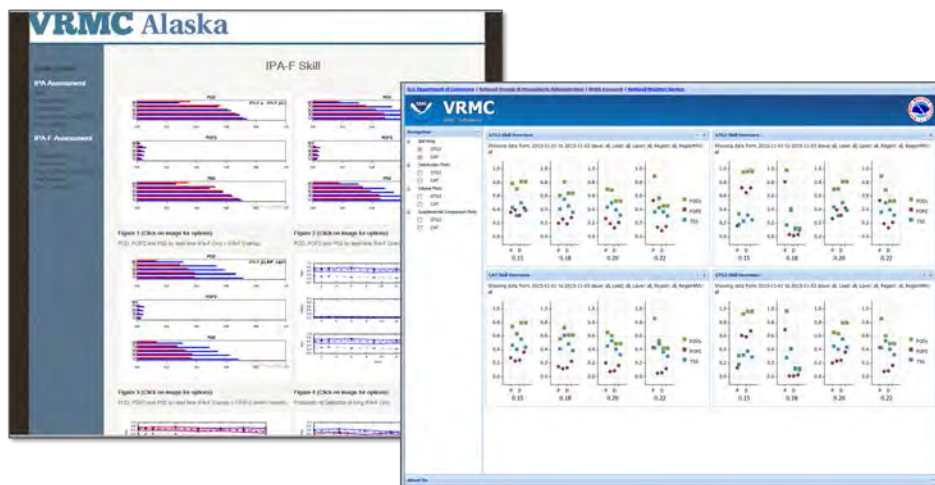

Figure 1. VRMC IPA-F Assessment Component (left) and GTG3 Monitoring Component (right) implemented in new UI framework.

Accomplishments for NWS ASWSB include:

CWSU Briefing and Verification Tool (CBVT; Figure 2):

NWS CWSUs (National Weather Service, Center Weather Service Units) provide decision support services at FAA Air Route Traffic Control Centers. The CWSU meteorologists provide briefings containing weather forecast information critical to FAA Traffic Flow Management decisions. FIQAS was tasked to develop an automated verification tool to allow user entry of briefing information and provide ongoing forecast performance results to replace what is currently a manual verification process performed by the individual CWSUs. The component to support wind event forecasts was completed for the 21 CWSUs in Oct 2016, and includes capabilities for forecasters to record the forecasts used for their wind event briefings, automated capabilities to identify observed wind events and verify the forecasts input into the system, and reporting capabilities for NWS Headquarters to track performance. Additional 2016/17 activities included development of concepts to support Ceiling and Visibility (C&V) forecasts, and implementation of backend processing and UI components to support C&V forecast input and verification.

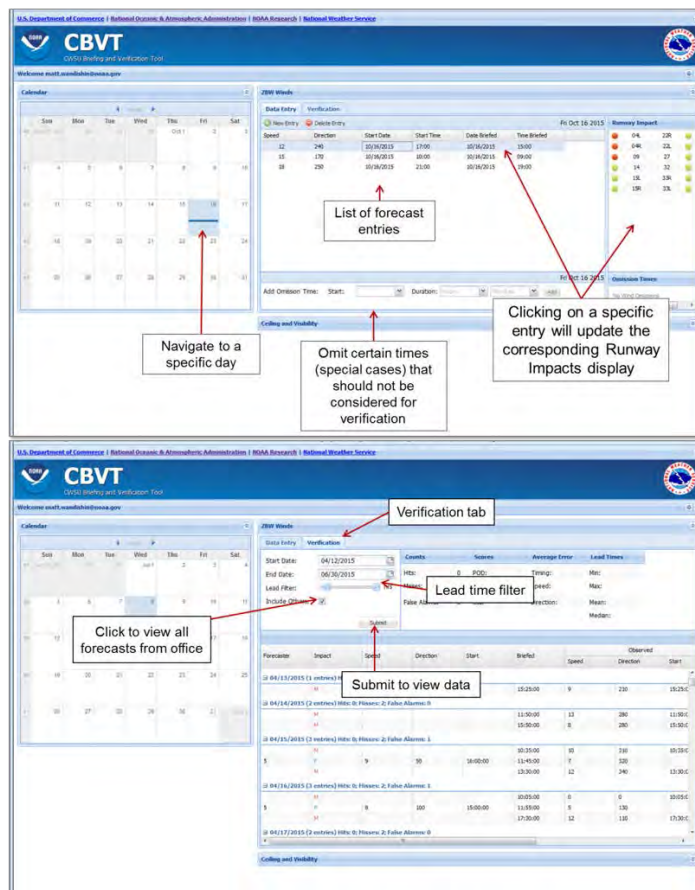

Figure 2. CBVT Briefing Entry (top) and Verification (bottom) pages.

TRACON (Terminal Radar Approach Control Facilities) Gate Forecast Verification Tool (TFVT; Figure 3): TRACON Approach and Departure gate forecasts are being produced by CWSUs to provide greater detail of convective occurrence with respect to TRACON activities. An automated, centralized version of this product has been developed by AWC to produce forecasts for a predefined set of CWSUs. FIQAS has developed an automated verification tool to support ongoing monitoring of performance of AWC's automated forecast product. Activities for 2016/17 include preparation of the tool to incorporate forecaster modifications to the automated AWC forecast, to provide performance comparisons between the forecaster-modified and automated forecasts.

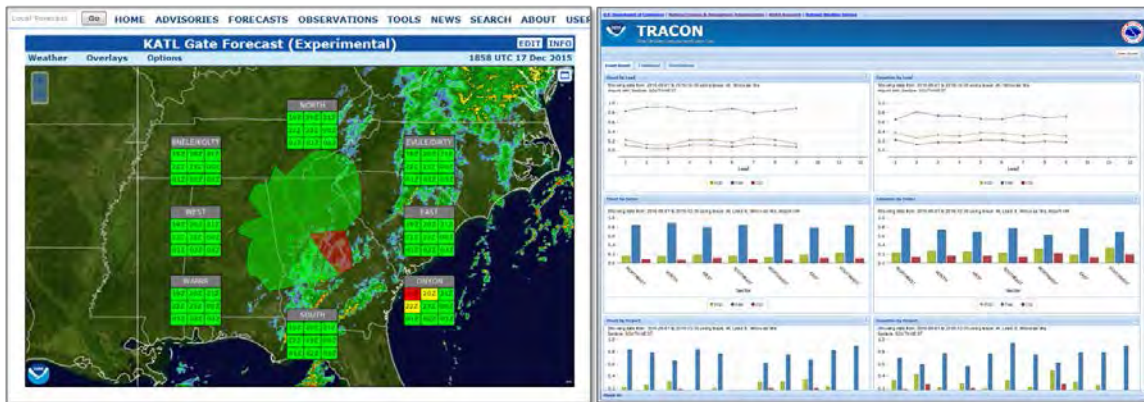

Figure 3. Example of TRACON Gate forecast (left) and TFVT web page (right).

Convective Weather Verification Service (CWVS):

FCI-based techniques used in the assessment of CCFP were incorporated into an automated tool to provide ongoing monitoring of CCFP performance. The tool was made publicly available in Jan 2017. Enhancements will occur later in 2017 to accommodate the change of the CCFP to the TFM Convective Forecast (TCF) and incorporate three variants of the product generated as part of the TCF process.

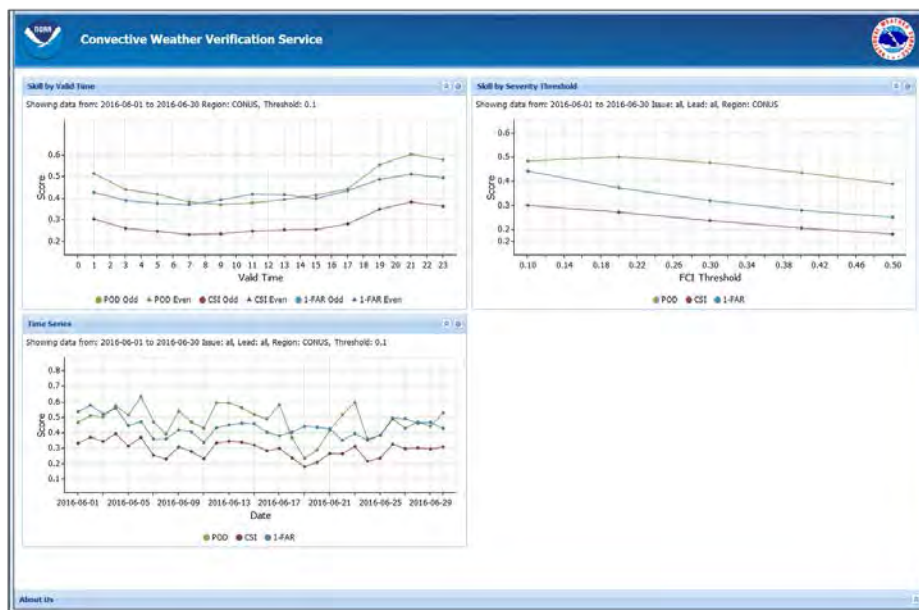

Figure 4. CWVS Web page.

Unification of Verification Capabilities into Verification Services for Aviation Forecast Evaluation (VSAFE): CBVT, TFVT, CWVS, and a tool known as Event-based Verification and Evaluation of NWS gridded products Tool (EVENT), are being incorporated into a common system known as VSAFE. VSAFE is planned for transition to the NWS to support verification of aviation forecasts supporting Traffic Flow Management.

Accomplishments for NWS OSTI include:

Integrated Support for Impacted air-Traffic Environments (INSITE; Figure 5):

INSITE is a web-based application developed for use in the convective weather forecast process. It aligns with NWS Weather Ready Nation initiatives to provide Impact Based Decision Support Services by

blending raw convective weather information with traffic data to highlight potential weather-related impacts to aviation operations. INSITE is targeted for use by NWS AWC forecasters, National Aviation Meteorologists, and CWSUs as part of their impact-based weather services to the FAA.

INSITE 4.0 was released May 2016, and will be the base version transitioned to NWS operations. Enhancements incorporated in this version included updates to the User Interface and the addition of an Alert Feature enabling users to quickly identify areas potentially impacted by convective weather. These enhancements were a result of user feedback gathered from AWC, the NAMs, and CWSUs. Preparatory activities for transition to NWS operations also occurred, but are currently on hold as the original planned host system (Integrated Dissemination Program) is currently at capacity.

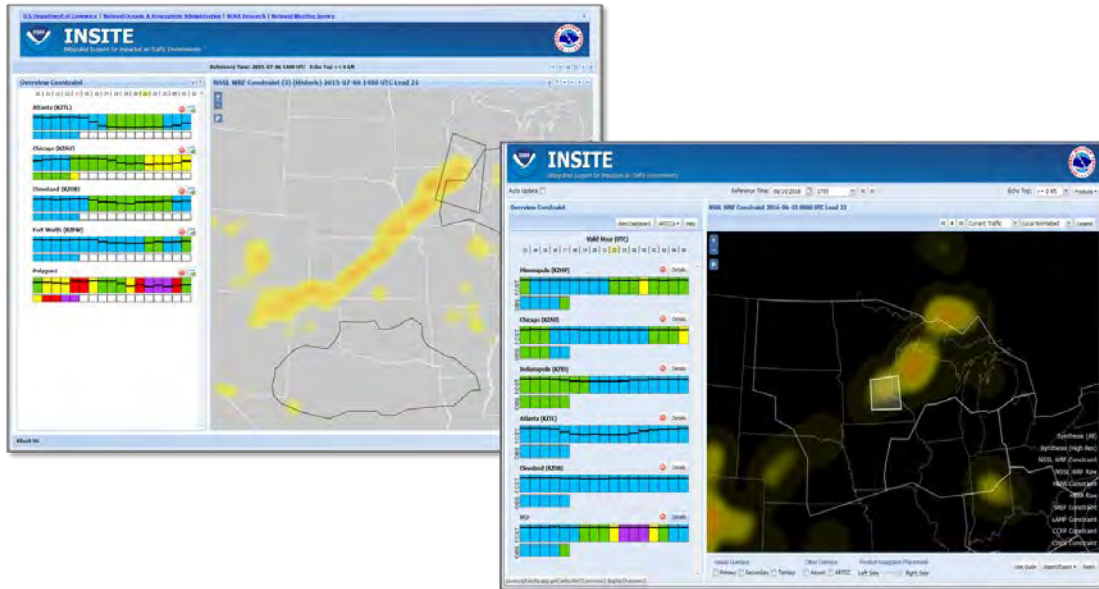

Figure 5. INSITE v 3.5 main page (left) and 4.0 enhancements (right).

PROJECT TITLE: EAR - Rapid Update Cycle (RUC) Rapid Refresh (RAP) and High-Resolution Rapid Refresh (HRRR) Models Project, Data Distribution and Visualization

PRINCIPAL INVESTIGATOR: Sher Schranz

RESEARCH TEAM: Brian Jamison, Ed Szoke

NOAA TECHNICAL CONTACT: Stan Benjamin (OAR/ESRL/GSD/ADB Chief)

NOAA RESEARCH TEAM: Curtis Alexander (CIRES), Steven Weygandt (OAR/ESRL/GSD/ADB)

PROJECT OBJECTIVES:

Tasks for this project include: creation and management of automated scripts that generate real-time graphics of output fields, management of web sites for display of those graphics, and management of graphics for hallway public displays.

PROJECT ACCOMPLISHMENTS:

Each of the web pages for RAP <http://rapidrefresh.noaa.gov/RAP/>, HRRR <http://rapidrefresh.noaa.gov/HRRR/>, and RUC <http://ruc.noaa.gov/RUC/> have been refined with new developmental model versions, difference plots, better graphics and new fields.

The HRRR is now an operational NWS model, and is run at The National Centers for Environmental Prediction (NCEP). GSD receives the operational data, and creates all graphics for GSD's HRRR web page, including all subdomains and soundings. The in-house HRRR was renamed HRRR Experimental (HRRRX) to distinguish it from the operational version.

By request from the NWS Cleveland office, a new HRRR subdomain over the Cleveland area was added in support of forecasting for the Republican National Convention, held in the Quicken Loans Arena.

The RAP version 3 and HRRR version 2 were released by The National Centers for Environmental Prediction (NCEP) and are received operationally at GSD. Graphics are created from these models and displayed on GSD's RAP and HRRR web pages, along with difference plots for comparison.

GSD is developing a HRRR Ensemble forecast model (HRRRE) consisting of up to 9 members. The HRRRE is directed towards severe storm forecasting. New reflectivity and updraft helicity graphics were developed to incorporate all members, and added to the suite of web graphics.

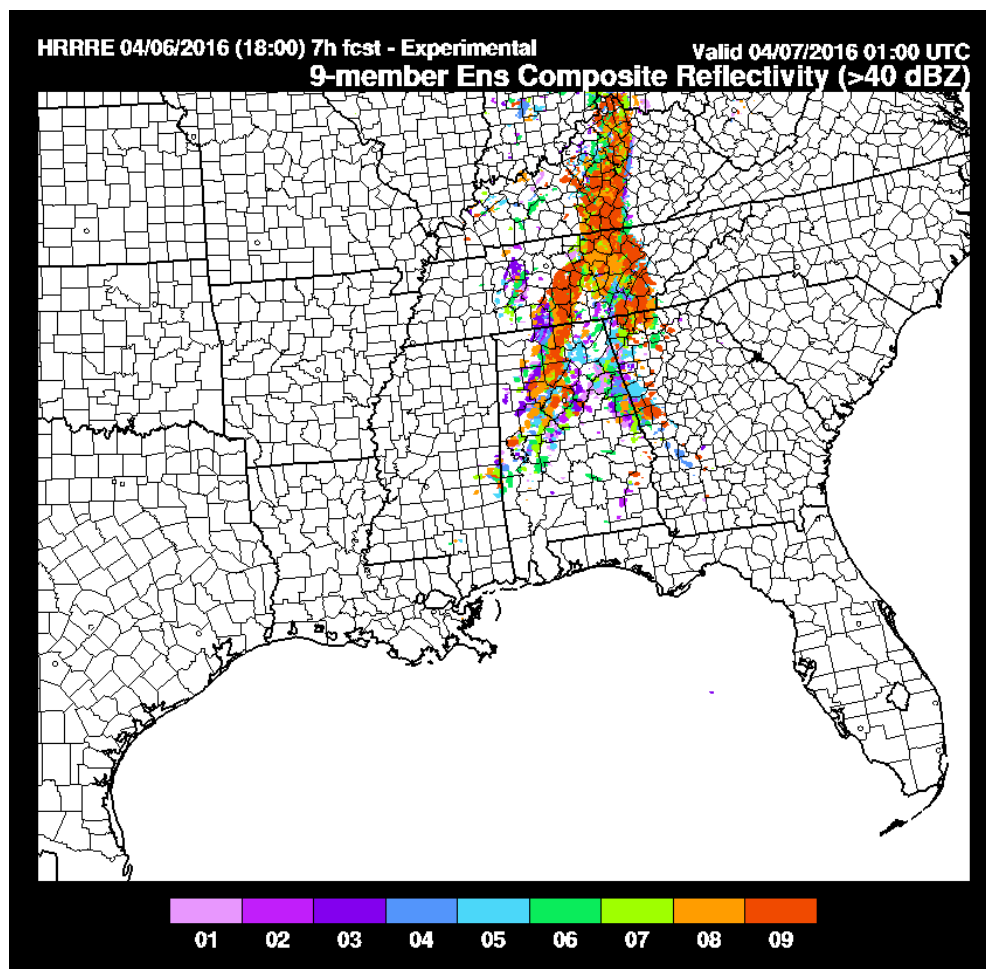

Figure 1. Example of HRRRE 9-member ensemble composite reflectivity.

New HRRR models for the dispersion of smoke over the continental US and Alaska (HRRR-smoke and HRRR-AK-smoke) were added, and GSD's web displays of these data are used daily by the U.S. Forest Service and air-quality managers. GSD also provides graphics files of this model output that can be used with Google Earth.

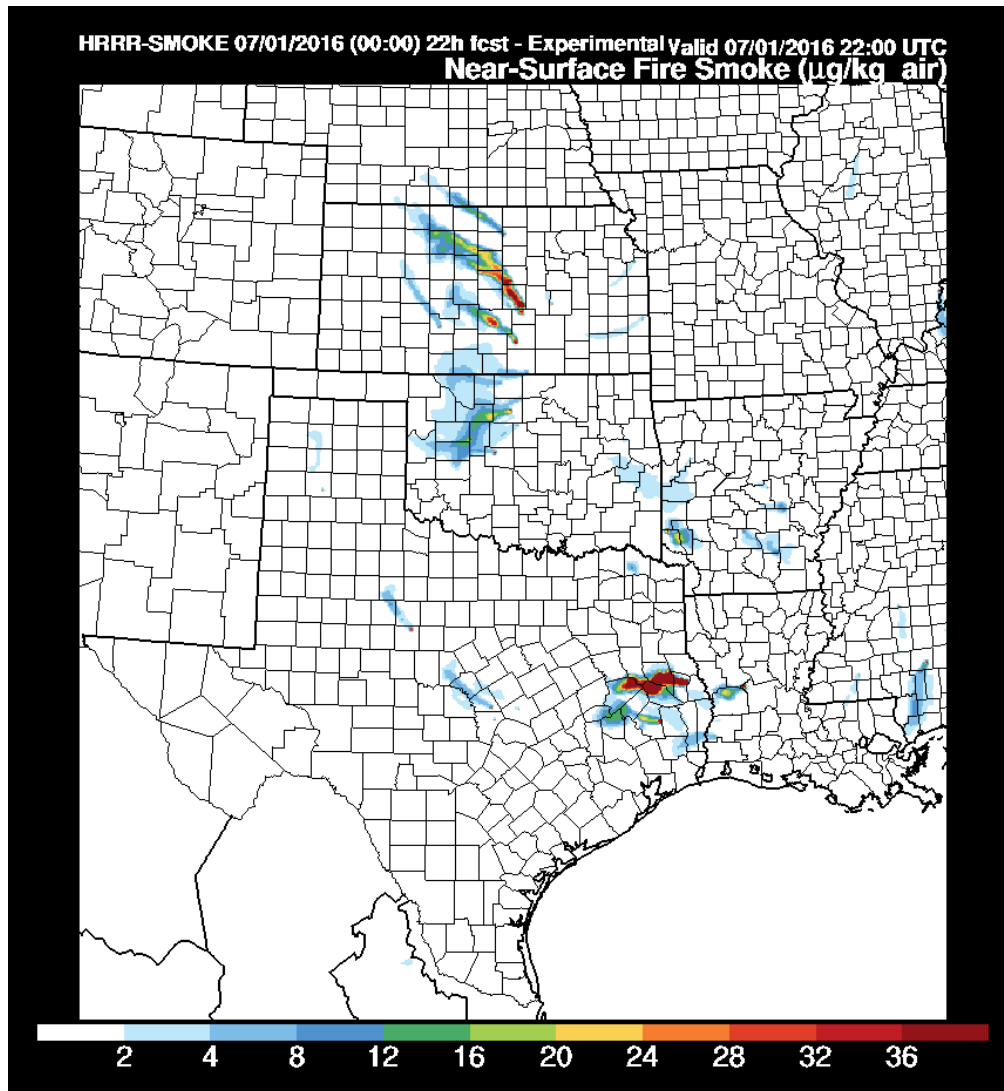

Figure 2. HRRR-smoke forecast for near-surface smoke dispersion.

Many improvements and some new products were added to the model suites, including the HRRR Real-Time Mesoscale Analysis (RTMA) and Rapidly Updating Analysis (RUA). New web pages were developed to view and loop both hourly and subhourly versions of these analyses over time.

Improvements were also made to the graphics workflow and synchronization to improve speed and availability, while also increasing web security.

A dual-monitor hallway display on the second floor of the David Skaggs Research Center (DSRC) displays HRRR model graphics for public viewing. Currently, a montage loop of four output fields is regularly displayed and updated automatically.

A large touchscreen kiosk monitor in the second floor atrium area has been updated with added HRRR graphic loops of composite reflectivity, precipitation and precipitation type. New, larger, and more detailed images were created and are updated specifically for the kiosk.

PROJECT TITLE: EAR – AWIPS I & AWIPS II Workstation Development

PRINCIPAL INVESTIGATOR: Sher Schranz

RESEARCH TEAM: James Ramer, U Herb Grote, Evan Polster, Amenda Stanley, Kevin Manross, Sarah Pontius, Nathan Hardin, Randy Pierce, Isidora Jankov

NOAA TECHNICAL CONTACT: Daniel Neitfeld (OAR/NOAA/ESRL)

NOAA RESEARCH TEAM: OAR/ESRL/GSD/EDS: Tracy Hansen, Thomas LeFebvre, Joseph Wakefield, Susan Williams, Vivian LeFebvre, Woody Roberts, Chris Golden (CIRES), Paul Schultz (CIRES), Xiangbao Jing (CIRES)

PROJECT OBJECTIVES:

The ongoing objective of this program is to research and maintain AWIPS-related service solutions for researchers and operational field personnel using those solutions, as well as supporting the NWS in the future development and delivery of those solutions. AWIPS I is the original Advance Weather Information Processing System used by the NWS Weather Forecast Offices (WFO) since the 1990's. AWIPS II (also known as A2) is the re-factored version of the AWIPS I system.

The long-term objective of this project is to develop a forecast workstation with advanced interactive display capabilities that includes inter-office and external collaboration, and integrates existing hazard services. The collaboration capability can improve forecast consistency between offices and permit better coordination with external partners.

PROJECT ACCOMPLISHMENTS:

Testing of Product Generation: Automated Test Framework (ATF):

In support of the testing of hazard product generation (HPG), CIRA personnel designed and implemented an application which can best be described as a HPG debugger. This tool allows HS developers to write individual test scripts decomposed into simple steps. These test scripts define the ability for hazard products to be created, modified, and ended; hazard "legacy text" results to be compared with expected results thereby proving hazard product generation correctness. The test scripts are dynamically interpreted facilitating quick turnaround testing. Deliverables over this time period include:

- Design and implementation of the HPG debugger along with integration into the existing framework.
- Migration of Python-based test scripts from the original testing framework. Python is chosen to eventually allow end users (forecasters, field specialists, etc.) to write their own test scripts for new, as-of-yet defined, hazard product types.
- Creation of Java-based "reference implementation" test scripts for facilitated test script development and Java debugging; the portion of the Hazard Services tools in the CAVE workstation that the ATF HPG debugger interact with are written in Java, hence the creation of Java-based tests.

AWIPS II Transition Task - Forecast Decision Support Environment - Ensemble Feature Migration:

CIRA personnel furthered their effort on the "Ensemble Tool" project, in support of migrating Advanced Linux Processing System (ALPS) ensemble features (including ensemble member product management and additional tools) into the AWIPS 2 Common AWIPS Visualization Environment (CAVE) workstation. The main delivery for the review period was integration into the OB17.3.1 release. Features and patches implemented over this time period include:

- Reengineered and enhanced usability of Matrix Navigation tool;

- Improved integration into the CAVE workstation;
- Compliance with architectural change requests by Raytheon Technical Services;
- User-controlled contour highlighting/intervals;
- Patches for general bug fixes;
- Project support for task/issue tracking; source code management; code-review processes; continuous integration; personnel guidance and support.

AWIPS II Transition Task - Migrate LAPS and MSAS to AWIPS-II:

This work was defunded at the end of FY17; less than one-person month was devoted to this task for the evaluation period. The work that was done can be broken into these subtasks:

Responded to a few trouble reports from sites that already have the A2 LAPS/MSAS running.

Participated in a couple of Technical Interchange Meetings, the goal of which was to transfer knowledge to the A-II contractor so they could take the lead on maintaining Laps and MSAS.

Development to fix the Data Access Framework scripts used by Laps and MSAS to retrieve data.

The LAPS/MSAS task was a joint effort with government staff from GSD's Evaluation and Decision Support Branch and the Earth Modeling Branch.

AWIPS I and II Formatters Task:

For the HLS/TCV formatters, the quality of the output produced was continued to be improved based on updated requirements and features and fixing bugs. Extensive feedback of the formatters was provided by continuing to use them on real hurricanes and tropical storms and there were also multiple weeks of intensive SWiT and beta testing. The tropical work done was NOAA Silver Medal award-winning work and Sarah Pontius received a 2016 CIRA Award for her work on implementing the formatters that are helping to better protect lives and property.

For the TAF formatter, the quality of the output was continued to be worked on based on feedback from forecasters. The primary focus was on working on ways to try to make the TAF output shorter, but not too short, while having it convey the most operationally significant meteorological conditions for pilots and air traffic controllers to help ensure safe takeoffs and landings for airplanes. In addition to fairly regular e-mail feedback and discussions from forecasters, there continued to be regular meetings to discuss the status of the project and discussions of what still needs improvement and ideas on how to achieve those improvements; as part of that, it was decided to start the smaller, more detailed focal point meetings back up again. The repository of the source code was also restructured to be more consistent with other repositories and development processes.

There was also work on a project to completely refactor the TAF formatter to use the product parts design. By switching to this design, it will better allow support for multiple formats; in particular, the TAC ASCII format (the current format) and the IWXXM-US 2.0 XML format, but also potentially other formats in the future. The design will make the code a lot cleaner, easier to understand, easier to modify, easier to understand and more.

AWIPS2 Hazard Services In-Flight Aviation:

Extensive progress was made in the past year with regards to developing Aviation In-Flight products within the Hazard Services framework. This work is being conducted as a replacement for the In-Flight products that the Meteorological Watch Offices (MWOs) currently produce in N-AWIPS and IC4D. Another impetus for this development is to establish a Common Aviation Platform for the three MWOs (Alaska Aviation Weather Unit, Honolulu Weather Forecast Office, and the Aviation Weather Center). Per the Statement of Work for the past year, the deliverables for developing In-Flight products in Hazard Services centered around demonstrating potential operational capability for the Convective SIGMET, International SIGMET, and AIRMET products.

- The role of CIRA/GSD personnel in this project is to:
- Gather requirements based on feedback from the National Weather Service (NWS) partners (MWOs and NWS Headquarters),
 - Conduct software design and conduct design reviews with partners,
 - Develop AWIPS2 code and tools to demonstrate operational functionality for the aforementioned products, and
 - Demonstrate capability and gather partner feedback at relevant testbed experiments.

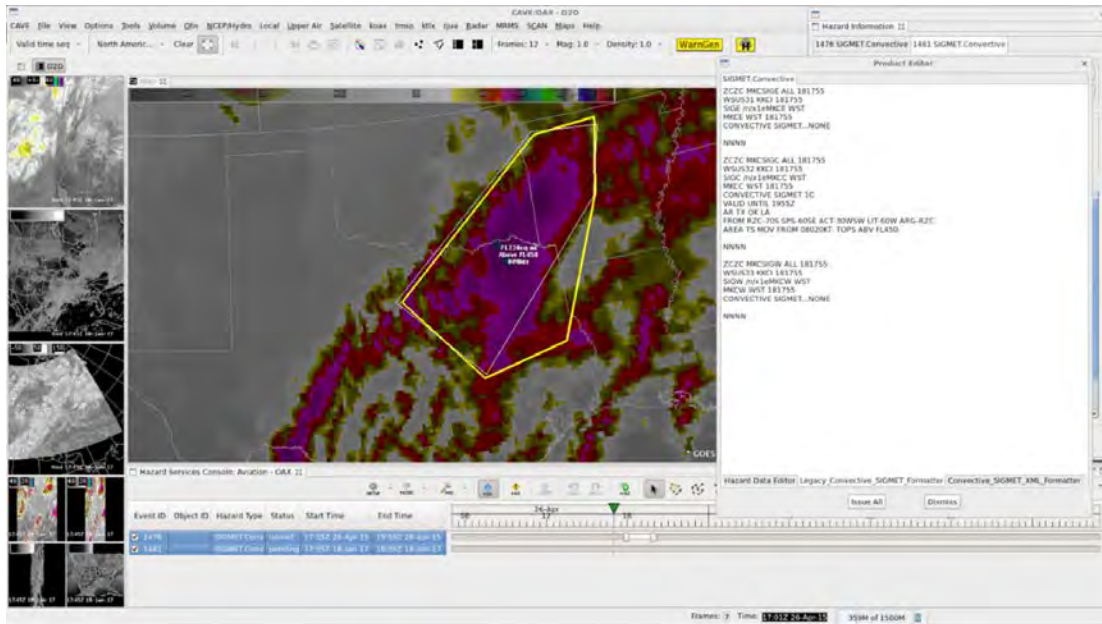

Figure 1. Sample Convective SIGMET and resultant text formatter required for dissemination.

A centerpiece of CIRA/GSD's development work for In-Flight capabilities is using partner input to develop automated tools that streamline the forecasting process. An example of this work is seen in Figure 2, where the user can define a potential volcanic eruption and run a tool that automatically populates the text formatter. This allows the forecasters to more quickly generate and issue the product, thus allowing their users to more quickly receive life-saving information.

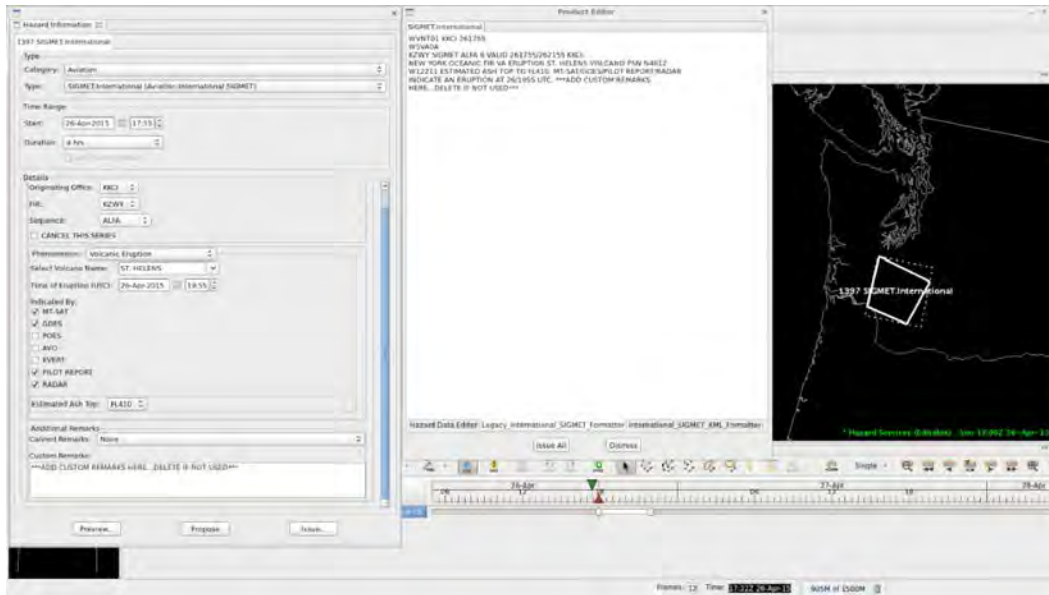

Figure 2. Sample volcanic eruption International SIGMET using automated tool developed by CIRA/GSD.

Some of this work was demonstrated at the Aviation Weather Testbed, held in Kansas City, MO in August of 2016. Partner and user feedback was fundamental in identifying pathways for future development. Additional feedback will be gathered on all products during the Arctic Weather Testbed, held in Anchorage, AK during the spring/summer of 2017. This feedback will drive development over the coming year as we move towards implementing full operational capability for the Convective SIGMET, International SIGMET, AIRMET, and Volcanic Ash Advisory products.

AWIPS2 Hazard Services Winter Weather Post-IOC:

A significant task for CIRA/GSD developers within the past year has been to develop and implement the ability to issue winter weather hazards using Hazard Services. This work is funded by the National Weather Service. GSD's role in this tasking includes:

- Elicit and gather feedback from NWS WFO forecasters about their existing winter weather product workflows,
- Conduct software design to reflect varied forecasting processes,
- Develop code, tools, and recommenders within Hazard Services for winter weather products.

A critical component of developing winter weather capabilities is the ability of Hazard Services and the Graphical Forecast Editor (GFE) to communicate reciprocally. Developing recommenders to create suggested hazards using the GFE forecast grids ensures consistency between the hazards and graphical forecast products. The capability of Hazard Services to communicate with GFE did not exist before this year. A hypothetical example of a hazard event being created directly from the forecasting grids can be seen in Figure 3. This work was completed by CIRA personnel, and is fundamental in replicating existing winter weather hazard workflows within the Hazard Services environment.

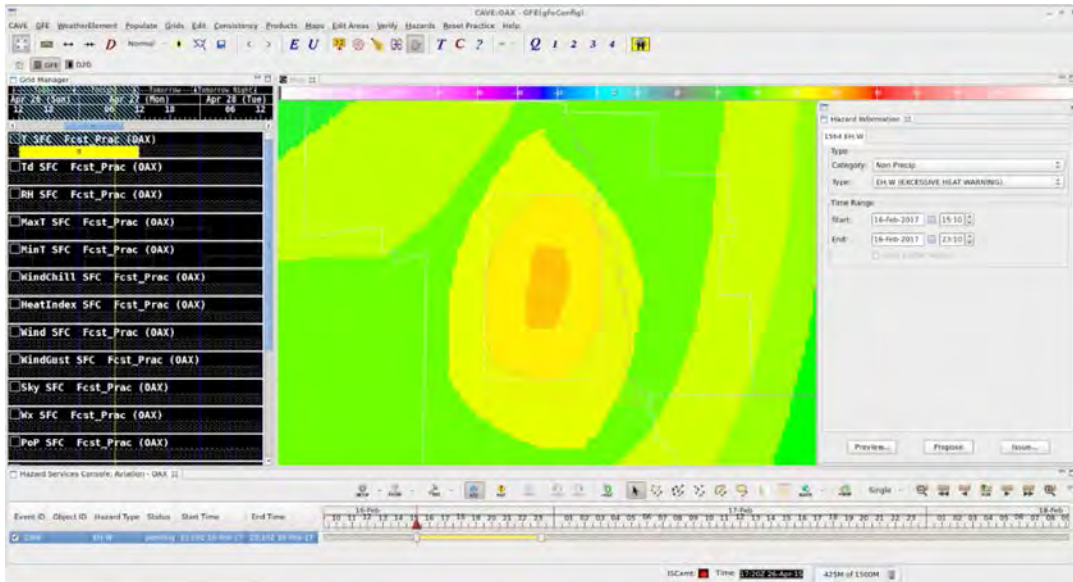

Figure 3. A hypothetical hazard event triggered using a threshold value in a GFE forecast grid.

Design, development, and implementation of Winter Weather Hazards in Hazard Services will continue into the coming year by CIRA/GSD personnel.

AWIPS2 Hazard Services National Hurricane Center Storm Surge:

Exploratory work was started this year by CIRA/GSD personnel, in partnership with the National Hurricane Center's (NHC) Storm Surge Unit (SSU), to investigate the benefits and challenges of constructing, collaborating, issuing, and disseminating information associated with the new Storm Surge Watch/Warning within Hazard Services. This is the first fully collaborative watch/warning between a NWS National Center (NHC) and Weather Forecast Offices (WFOs). Currently constructed in GFE, the high-resolution hazard is impeded by GFE's relatively coarse grid spacing (2.5 km). Hazard Services allows the integrity of the probabilistic guidance (~625 meters) to be preserved during the watch/warning workflow. An example of preliminary development can be seen in Figure 4.

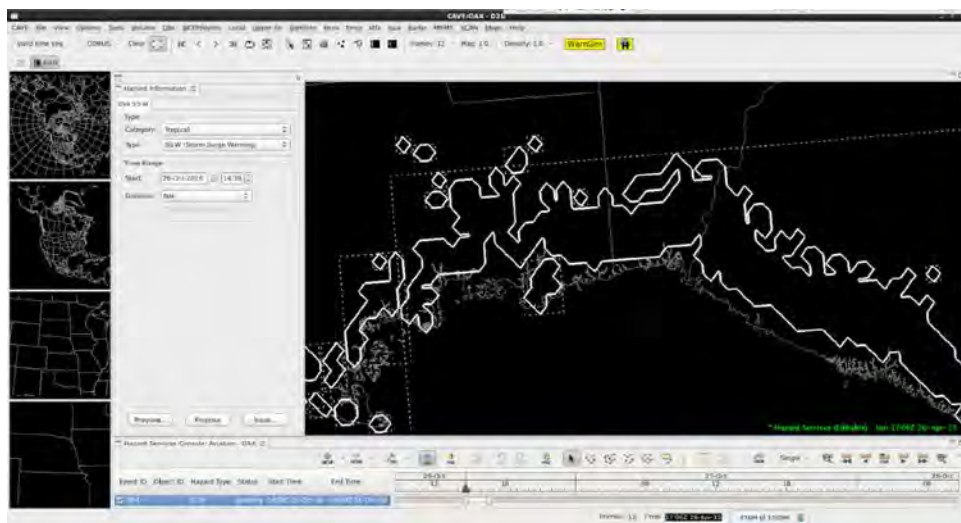

Figure 4. Hypothetical example of a Storm Surge Warning constructed in Hazard Services, zoomed in.

The recommender to create this output reads in probabilistic model guidance created by SSU and suggests a proposed Storm Surge Watch or Warning as a starting point for collaboration. Using Hazard Services to create the watch/warning results in a more accurate hazard than one constructed in GFE. Preserving the resolution of the guidance ensures proper spatial extent of the hazard, in addition to providing better messaging to partners, users, and the general public. Exploratory efforts and development will continue on this project into the coming year, with the goal of ensuring consistent messaging between SSU products during landfalling tropical systems.

Probability of What (PHI into AWIPS2 Hazard Services)

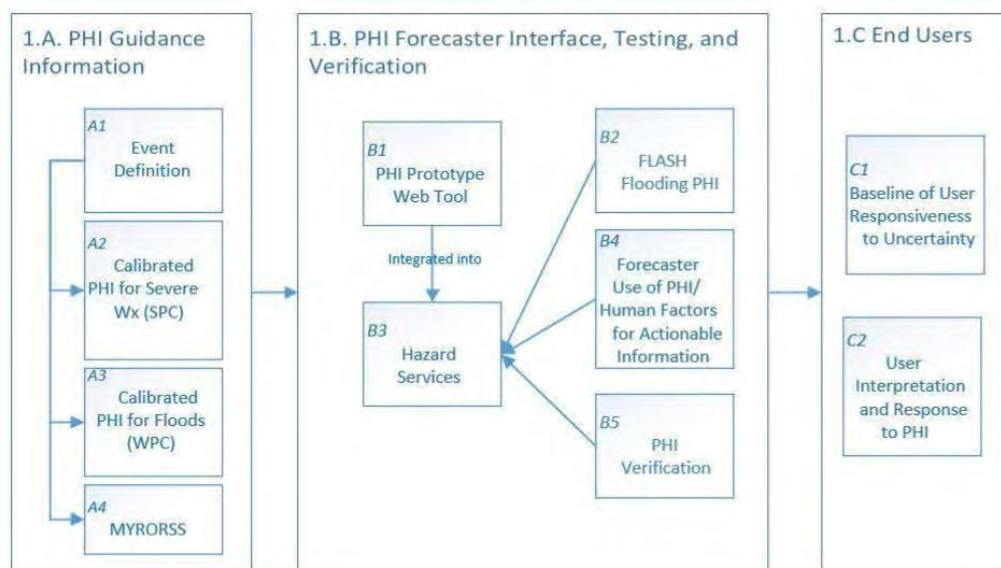

Figure 5. “Probability of What” concept map.

Forecasting a Continuum of Environmental Threats (FACETs) is a proposed next-generation severe weather watch and warning framework that is modern, flexible, and designed to communicate clear and simple hazardous weather information to serve the public. <<http://www.nssl.noaa.gov/projects/facets/>> FACETs supports NOAA's Weather-Ready Nation initiative to build community resilience in the face of increasing vulnerability to extreme weather and water events.

This past year coincided with year two of three of the US Weather Research Program (USWRP) awarded funding to support the “Probability of What” - a collaborative effort between NSSL, WPC, SPC, GSD, University of Oklahoma, University of Akron. This Research to Operations effort is the first to implement the (FACETs) concept into the National Weather Service. A key aspect of implementing the various subtasks of this project to operations is leveraging the AWIPSII Hazard Services plugin as a conduit.

The specific focus of CIRA/GSD personnel has been task B3 (Figure 5): integrating the functionality of NSSL’s Probabilistic Hazards Information (PHI) web prototype tool into Hazard Services. The “PHI into Hazard Services” work is the backbone of the FACETs initiative. The general PHI concept is that NWS forecasters, as well as objectively analyzed output, provide uncertainty information for impact weather in the form of a geospatial probabilistic grid that would be available to end users. The NSSL prototype functionality has several years of NWS forecaster and human factors expert input.

GSD is leveraging a branch of Hazard Services to implement the functionality of the NSSL prototype which would allow forecasters to analyze impact weather and produce PHI grids within AWIPS2. Specifically, CIRA/GSD personnel have done the following:

During Year Two of this task, the following was accomplished:

- Incorporating feedback from forecasters, researchers and testers during last year's testing at the NOAA Hazardous Weather Testbed.
- Development and refinement of a distributed processing of a "first-guess" algorithm quantifying severity of observed storms supplied by CIMSS (Madison, WI), called "ProbSevere" into the Hazard Services framework.
- Developing multiple levels of automation (from fully automated to fully manual as well as two intermediate levels of hybrid forecaster-automation).
- Maturing visual features for display and interactivity.
- Analyzing development and testing workflow that allowed close collaboration between the developers at GSD and testers at the Hazardous Weather Testbed in Norman, OK.

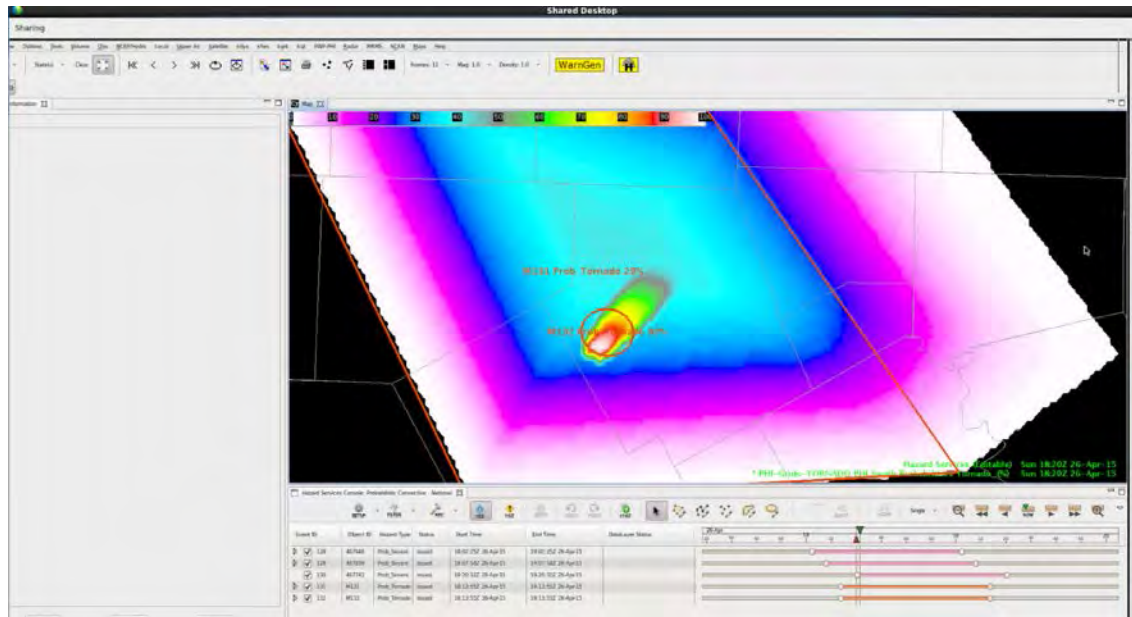

Figure 6. PHI Grid of low background level tornado probabilities with embedded higher tornado probability for an existing storm. This illustrates the FACETS concept of longer fuse, rapidly updating information. This concept has been successfully employed within the AWIPS II system via experimental branch of Hazard Services.

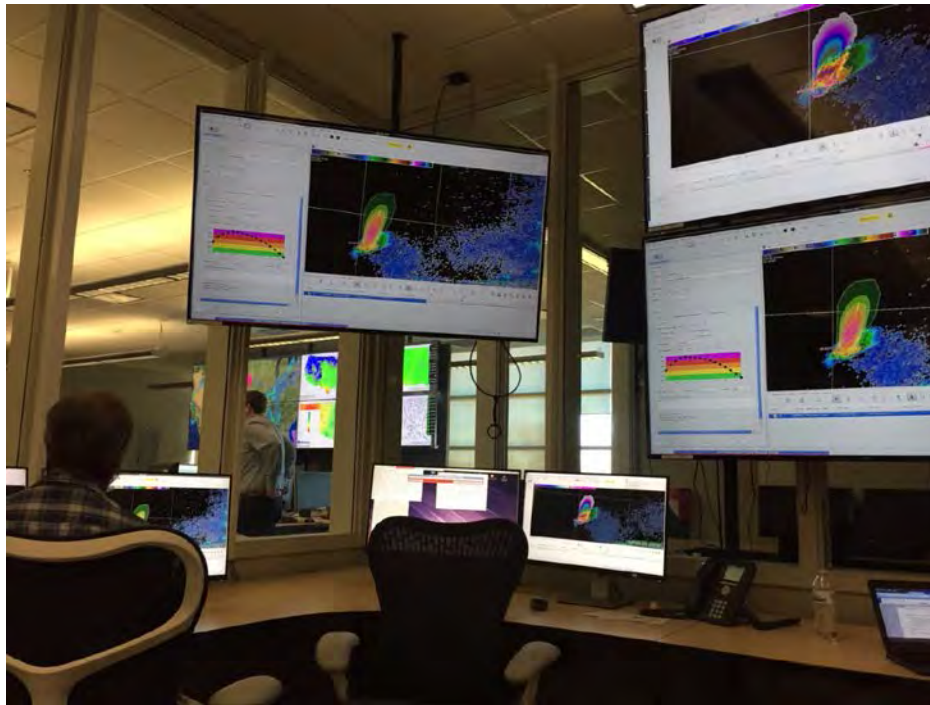

Figure 7. Year Two testing in the NOAA Hazardous Weather Testbed of Hazard Services - PHI.

Testing in the HWT is ongoing and shows significant growth from Year One to Year Two.

AWIPS I Ongoing Task - FX-Net Project (Now referenced as the AWIPS II FxCAVE Project)

The FX-Net project completed its 19th year in 2016.

The FX-Net project included an AWIPS I based data delivery service for FX-Net and Gridded FX-Net workstations. The former was a Java-based desktop application that emulated AWIPS I D/2D workstation and the latter actually being a combined AWIPS I data server and D/2D application combined into one desktop machine. Both workstations were fed by an AWIPS I data ingest infrastructure which included a fault-tolerant pair of four server hosts: communications processor, data server, application server, and load balancer. The Gridded-Fx-Net workstation was additionally fed by a spooler, compression manager, and Local Data Manager (LDM) server.

Ongoing production of service included maintaining a high-availability meteorological data service for field customers who include the National Interagency Fire Center (NIFC), and the Chief Presidential Support Element in charge of the Executive Fleet at Andrews AFB, as well as local laboratory researchers.

FX-Net as a service solution was terminated on September 30, 2016, being replaced by the AWIPS II based FxCAVE Project.

Customers of the FX-Net service have been migrated to the new FxCAVE service.

AWIPS II Extended Task - FxCAVE Project

The FxCAVE project is the name of the AWIPS II thin-client service/workstation which has replaced the AWIPS I FX-Net service/workstation.

FxCAGE as a service solution is composed of the AWIPS II application (EDEX) servers and a pared-down version of the Common AWIPS Visualization Environment (CAVE) meteorological workstation, which has been rebranded to the Forecast eXperimental CAVE (FxCAGE).

The FxCAGE mission includes:

- Provide AWIPS II data services to remote and local users of FxCAGE.
- Maintenance and support of eleven (11) physical FxCAGE workstations at NIFC field offices.
- Creation and maintenance of eight (8) FxCAGE virtual machine (VM) desktops workstations.
- Maintenance and support of research-regular production-based EDEX data servers.

These services include continual support of the National Interagency Fire Center (NIFC) and their satellite Geographical Area Coordination Center (GACC) offices, and the Chief Presidential Support Element in charge of the Executive Fleet at Andrews AFB.

PROJECT TITLE: EAR - Meteorological Assimilation Data Ingest System (MADIS)

PRINCIPAL INVESTIGATORS: Sher Shranz

RESEARCH TEAM: Tom Kent, Leigh Cheatwood-Harris, Randall Collander, Michael Leon, Amenda Stanley, Richard Ryan, Glen Pankow, Patrick Hildreth, Chris MacDermaid

NOAA TECHNICAL CONTACT: Greg Pratt (OAR/ESRL/GSD/ATO)

NOAA RESEARCH TEAM: Leon Benjamin (CIRES), Gopa Padmanabhan (CIRES), Michael Vrencur (ACEINFO)

PROJECT OBJECTIVES:

- Continue to add new functionality and data sources to MADIS.
- Provide support to the user community.
- Continue to transition new and enhanced MADIS research to operations at NWS NCEP.

PROJECT ACCOMPLISHMENTS:

MADIS is dedicated toward making value-added QC data available for the purpose of improving weather forecasting. MADIS data helps to provide support for use in local weather warnings and products, data assimilation, numerical weather prediction, and the whole meteorological community in general. This is accomplished by partnerships with both federal and state government agencies, universities, airlines, private companies, and individual citizens.

CIRA researchers continue working on a suite of research to operations tasks with varying degrees of completion. MADIS has or is in the process of integrating IOOS, HADS, AFWS, CLARUS, SNOTEL, NGITWS, and NWS Data Delivery systems into MADIS IDP operations at NCO. Many new data providers were added as well as a more automated testing and implementation process to improve future release efficiency.

MADIS achieved Final Operating Capability (FOC) at the NWS National Centers for Environmental Prediction (NCEP) Central Operations (NCO) in Jan, 2015. The NCO facility is located in College Park, MD and is the center of operations with its new Integrated Dissemination Program (IDP) infrastructure for NOAA wide data dissemination. With the major new 2.1.5 software release in 2016 for the IDP, MADIS has some new high profile additions:

IOOS (Integrated Ocean Observing System) - MADIS began handling IOOS data with a new decoder developed in conjunction with some of the National Mesonet Program data providers. The MADIS decoder leveraged work done by the NMP partners which included standardizing the CSV data and header formats so that future IOOS formatted data can quickly be added to the system due to the self-describing nature of the IOOS standard. More work is continuing on the standards for the IOOS metadata using *FL (Starfish Fungus Language) which is part of a larger MADIS effort on standardizing all metadata.

CLARUS - A lot of work was done by MADIS to integrate CLARUS into MADIS to transition Department of Transportation (DoT) data, metadata, and QC algorithms to operations at NCO. The CLARUS QC will be applied to data in addition to the MADIS QC. This work will continue in 2017.

HADS (Hydrometeorological Automated Data System) and AFWS (Automated Flood Warning System) - These very reliable and important hydro systems were migrated into MADIS to achieve cost efficiencies and consolidation for NOAA. The HADS is a mission essential function that acquires, processes, and disseminates critical hydrological and meteorological data to the National Weather Service (NWS) Field Offices to protect life and property. The AFWS was added to the HADS system in 2013 to include ALERT, ALERT2, and IFLOWS hydro data into the HADS system. HADS produces tailored Standard Hydrometeorological Exchange Format (SHEF) text products for the River Forecast Centers (RFCs), Weather Forecast Offices (WFOs), and for National Centers for Environmental Prediction (NCEP) from GOES DCP data. HADS also processes the AFWS data to produce both SHEF encoded text products as well as Hydrologic Markup Language (HML) products. These products are disseminated through the NWS Telecommunications Gateway infrastructure. Additionally, HADS maintains a web site where GOES DCP meta-data and decoded data are made available to the NWS, HADS stakeholders, all levels of governments, as well as the general public. There has been a lot of progress to integrate these systems into MADIS and the complex nature of multiple databases, data clients, and web interfaces took a lot of effort and collaboration with many different groups within NWS.

SNOTEL (SNOWpack TELemetry) - This system collects data in Alaska and several western states to produce water supply forecasts. There are currently about a 1000 stations reporting hourly, daily, and monthly data. Climate studies, air and water quality investigations, and resource management concerns are all served by the modern SNOTEL network. The high-elevation watershed locations and the broad coverage of the network provide important data collection opportunities to researchers, water managers, and emergency managers for natural disasters such as floods. MADIS spent several months integrating this valuable dataset into operations at the IDP.

NGITWS (NextGen IT Web Services) - The NextGen congressionally mandated requirement is to provide enhanced weather forecast information required for integration into an air traffic management system, using an Open Geospatial Consortium (OGC)-compliant net-centric weather information dissemination capability. This year efforts focused on the delivery of all Product Data Descriptions documents for all products listed in the NOAA/FAA Product Delivery List. The MADIS team has created three OGC templates for this data delivery:

- Web Coverage Service Data
- Web Feature Service Data
- Web Mapping Service Data

The MADIS team has also worked on automating the creation of these PDD documents and worked to define a process that efficiently and cost effectively allows these documents to be maintained by NWS and incrementally improved as required. The definitions and processes the MADIS team created for PDD development can be used to handle all metadata creation and improvements and will be briefed to NWSHQ later this year.

NWS DATA DELIVERY - MADIS has worked with Raytheon to reconfigure the MADIS Data Provider Agent for release to run at NCO. While waiting for NCO operational VMs to become available in 2017,

these DPA capabilities are hosted at GSD on MADIS systems that both NWS AWIPS test and operational systems access.

PROJECT TITLE: EAR - Citizen Weather Observer Program (CWOP)

PRINCIPAL INVESTIGATORS: Sher Shranz

RESEARCH TEAM: Leigh Cheatwood-Harris, Randall Collander, and Tom Kent

NOAA TECHNICAL CONTACT: Greg Pratt (OAR/ESRL/GSD/ATO)

NOAA RESEARCH TEAM: Leon Benjamin (CIRES), Gopa Padmanabhan (CIRES), Michael Vrencur (ACEINFO)

PROJECT OBJECTIVES:

The Citizen Weather Observer Program (CWOP) database is now maintained by the MADIS Staff. CIRA researchers administer the CWOP through database updates (adding new stations, removing stations no longer reporting data, and maintaining accurate site location information), interactions with CWOP members (answering questions and discussing suggestions, and investigating data ingest and dissemination issues), refreshing related web pages and documents, verifying that station listings and other reference data required by MADIS are complete and accurate, and confirming that routine backups of database and related files are performed. The CWOP is a public-private partnership with three main goals:

- 1--Collect weather data contributed by citizens.
- 2--Make these data available for weather services and homeland security.
- 3--Provide feedback to the data contributors so that they have the tools to check and improve their data quality.

There are currently 21,400 active stations (citizen and ham radio operators) out of a total of 34,974 stations in the CWOP database. CWOP members send their weather data via internet alone or internet-wireless combination to the findU (<http://www.findu.com>) server and then the data are sent from the findU server to the NOAA MADIS ingest server every five minutes. The data undergo quality checking and then are made available to users thru the MADIS distribution servers. CWOP is in the process of transitioning to operations within the NCO IDP MADIS system.

PROJECT ACCOMPLISHMENTS:

This past year the process of transitioning CWOP to run inside MADIS began. The first major step was taking the hundreds of thousands of links from the CWOP web site and organizing them to streamline the same capability within the MADIS web domain. This resulted in the reduction of thousands of links as well as a more clearly defined interface to search for information about CWOP and its data. More database procedures were enhanced through development and implementation of scripts to auto-correct missing and typographical errors in new member sign-up requests, and through introduction of automated site geographic location and elevation verification algorithms. Interactions occurred with users via email regarding site setup, data transmission issues, quality control and general meteorology. Various web-based documents and databases were updated on a daily, weekly or monthly basis depending on content, and statistics and other informational graphics revised and posted. These improvements were all done with the intent to mesh with the current and future work on standardization of MADIS metadata.

In 2016, there were approximately 2240 stations added to the database. Approximately 1685 revisions were made to site metadata. Adjustments include latitude, longitude and elevation changes in response to site moves, refinement of site location, and site status change (active to inactive, vice-versa).

PROJECT TITLE: EAR - Research Collaborations with Information and Technology Services

PRINCIPAL INVESTIGATOR: Sher Schranz

RESEARCH TEAM: Leslie Ewy, Patrick Hildreth, Robert Lipschutz, Richard Ryan, Amenda Stanley, and Jennifer Valdez

NOAA TECHNICAL CONTACT: Scott Nahman (OAR/ESRL/GSD/ITS Chief)

PROJECT OBJECTIVES:

CIRA researchers in the GSD Information and Technology Services (ITS) group develop and maintain systems that acquire, process, store, and distribute global meteorological data in support of weather model and application R&D projects throughout GSD. The CIRA team collaborates with ITS systems, networking and security specialists and numerous GSD researchers to provide services that meet the specified requirements. CIRA staff also participate as team members of several projects within other GSD branches. In addition, a CIRA researcher in the group serves as the ESRL/GSD Webmaster, implementing and maintaining a wide range of web-based services for the Division.

PROJECT ACCOMPLISHMENTS:

--GSD Central Facility - CIRA researchers continue to manage a six-host data processing cluster, as well as a number of other virtual systems that collectively acquire, process, store, and transport data to meet GSD requirements. By the end of the year, the system was handling over 3.5 TB of meteorological data daily for users within GSD and on the NOAA R&D High Performance Computing Systems (RDHPCS). Selected GSD data sets were also made available through FTP, Local Data Manager (LDM) and web services established and maintained by the CIRA ITS team.

The CIRA team established a number of new real-time data sets within the Central Facility and RDHPCS environments, including:

- Visible Infrared Imaging Radiometer Suite (VIIRS) Green Vegetation Fraction,
- VIIRS Active Fire Environmental Data Records,
- Microwave Integrated Retrieval System (MIRS),
- National Ice Center Sea Ice Coverage,
- Regional ATOVS Retransmission Services (RARS) Sounder products,
- Tropical Cyclone Tracks,
- Air Force Weather Agency (AFWA) World Wide Merged Cloud Analysis (WWMCA), and
- South American AMDAR (Aircraft Meteorological Data Relay) observations.

In addition, the CIRA team collaborated with ITS systems staff and data users to improve data flow and resource utilization within the Central Facility, including designing and configuring a new system for more efficiently transferring data sets from the GSD Central Facility storage server to the NOAA RDHPCS system known as 'jet,' re-engineering data transport for large model data sets generated on jet that need to be posted to back to internal GSD storage locations for subsequent processing and distribution, identifying and resolving other resource bottlenecks and inefficiencies, and decommissioning several legacy physical systems. The team also transitioned GSD's Thematic Real-time Environmental Distributed Data Services (THREDDS) systems to support HTTPS access.

At the end of the period, the CIRA ITS group achieved a long-term goal of transitioning the six physical hosts of the Central Facility's Data Cluster (DC), which had been in production since 2009, to a new virtualized Central Facility Data (CFD) system. The new system provides expanded capacity and simplified management within GSD's virtual infrastructure. As depicted schematically in Figure 1, the CFD comprises six hosts that utilize the Unidata Local Data Manager (LDM) for data transport and event-

driven job activation, 'fcron' for time-based job activation, and Grid Engine (GE) for load-balanced job scheduling across the system.

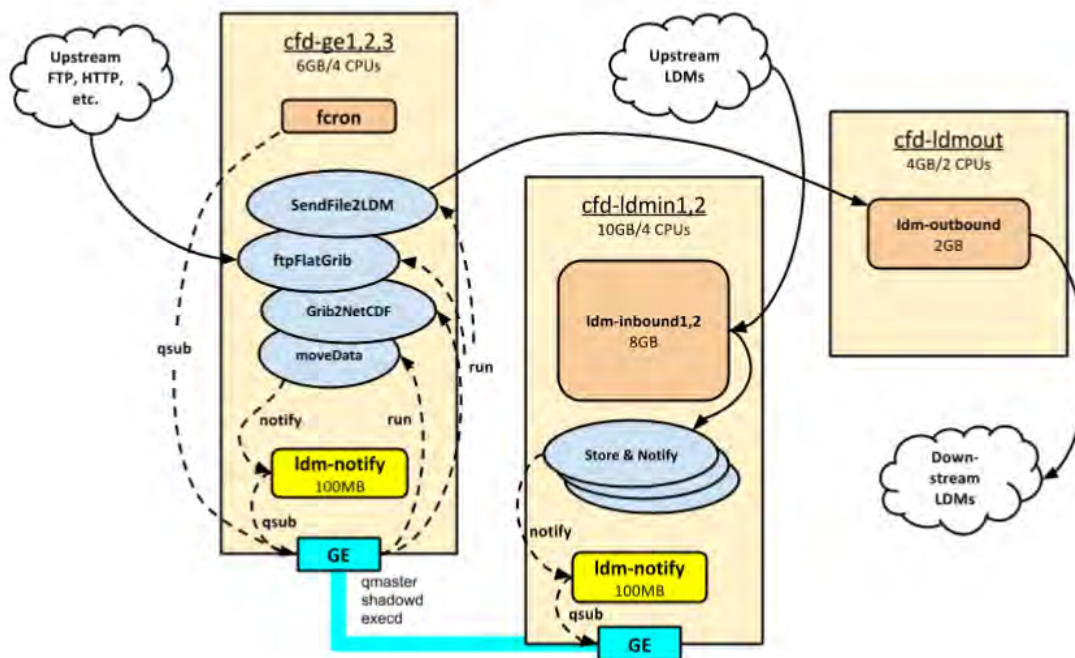

Figure 1. Logical flow within the Central Facility Data (CFD) system.

--MADIS (Meteorological Assimilation Data Ingest System) - The CIRA ITS team provided direct support to the MADIS project and was instrumental in enabling MADIS version 2.1.5 to achieve operational status within the NOAA Integrated Dissemination Program (IDP), thereby completing a NOAA Oceanic and Atmospheric Research (OAR) Operating Plan milestone. The effort included software developed by the CIRA group as part of the Hydrometeorological Automated Data System (HADS), Automated Flood Warning Systems (AFWS), and Snow Telemetry (SNOTEL) components.

--FXNet - The CIRA ITS team provided direct support to GSD's FXNet Fire Weather project by working with the FxCAVE team to support FXNet/FxCAVE fire weather customers via AWIPS2-based systems. This effort enabled AWIPS1-based systems to be decommissioned at the end of FY16.

--NextGen IT Web Services Program (NGITWS) – The CIRA ITS team completed its collaboration with researchers from NOAA's Meteorological Development Laboratory, NOAA's Aviation Weather Center, and NCAR to develop web-based data dissemination services, delivering several Product Description Documents (PDDs) to the project lead.

--GSD Web Services - CIRA ITS team member Jennifer Valdez serves as GSD Webmaster, providing numerous services to GSD scientists, RDHPCS management, and external community members. Her notable activities for the period included:

- transitioning GSD web sites from HTTP to HTTPS,
- revamping the internal GSD web site (intranet),
- reviewing all GSD web sites for compliance with NOAA standards and content, with an emphasis on determining the need to keep the site or to archive the material,
- working with GSD scientists and developers to reduce the number of top-level web sites managed by GSD, and
- updating and maintaining scripts for the GSD Publications database.

PROJECT TITLE: EAR - Science On a Sphere® (SOS) Development

PRINCIPAL INVESTIGATOR: Sher Schranz

RESEARCH TEAM: Keith Searight, Steve Albers

NOAA TECHNICAL CONTACT: John Schneider (OAR/ESRL/GSD/ATO Chief)

NOAA RESEARCH TEAM: CIRES: Shilpi Gupta, Vincent Keller, Ian McGinnis, Stephen Kasica, Dr. Wen Wei (Tony) Liao

PROJECT OBJECTIVES:

- 1--Continue to develop and enhance near-real-time and other global data sets for use at SOS sites.
- 2--Provide software and technical support for existing SOS systems sites, new and proposed SOS installations, and travelling SOS exhibits that conduct scientific education and outreach.
- 3--Plan and release new versions of the SOS system software with prioritized features.
- 4--Research new technologies and configurations for future innovations in SOS.

PROJECT ACCOMPLISHMENTS:

The Science on a Sphere® (SOS) Development project advances NOAA's crosscutting priority of promoting environmental literacy. SOS displays and animates global data sets in a spatially accurate and visually compelling way on a 6-foot diameter spherical screen. CIRA provides key technical leadership and developments to the SOS project, particularly research and implementation of effective controls and user interfaces for the system, new visualization techniques, and new data sets.

1--Near-real-time and other global data sets

The SOS team continued to support the automated transfer of large volumes of near-real-time weather model data to SOS sites via private FTP. Recently collected statistics have documented a monthly average of 26 TB of SOS datasets downloaded, about an 85% increase in volume over the previous reporting year.

Highlights for this reporting period include:

--A new SOS dataset, Earthquakes - 2001-2015, created by the NOAA Tsunami Warning Center was added to the SOS data catalog in Nov. 2016. In Dec., a video of the dataset was posted to the SOS Facebook page and to-date has had 8 million views, 225K shares, 36K likes, and 3K comments, making it the most popular SOS dataset ever posted to the Internet.

--A new overlay showing capital city locations and names for all countries was created.

--Continued maintaining real-time weather models (Global LAPS, FIM, GFS) on SOS. Other real-time datasets being developed and maintained include global weather satellite and earthquakes.

--A new dataset for Paleo climate (temperature changes) for the past 1500 years has been developed in collaboration with NOAA's National Centers for Environmental Information (NCEI).

--Improved versions of some solar system datasets were made, including a new Titan radar dataset (shown as an overlay), new Mercury topography, and labels for surface features on Charon.

--Set up images and animations of new data from the NOAA/NASA Deep Space Climate Observatory (DSCOVR) satellite, providing unique views of planet Earth. These include a transit of the moon across the Earth. Comparison of simulated DSCOVR imagery using global models vs actual data from DSCOVR is also being tested.

--Created a visually realistic simulation of the moon's shadow moving over the Earth during the upcoming Aug 21, 2017 solar eclipse, with detailed consideration of the celestial mechanics and other aspects of the Earth's surface and atmosphere.

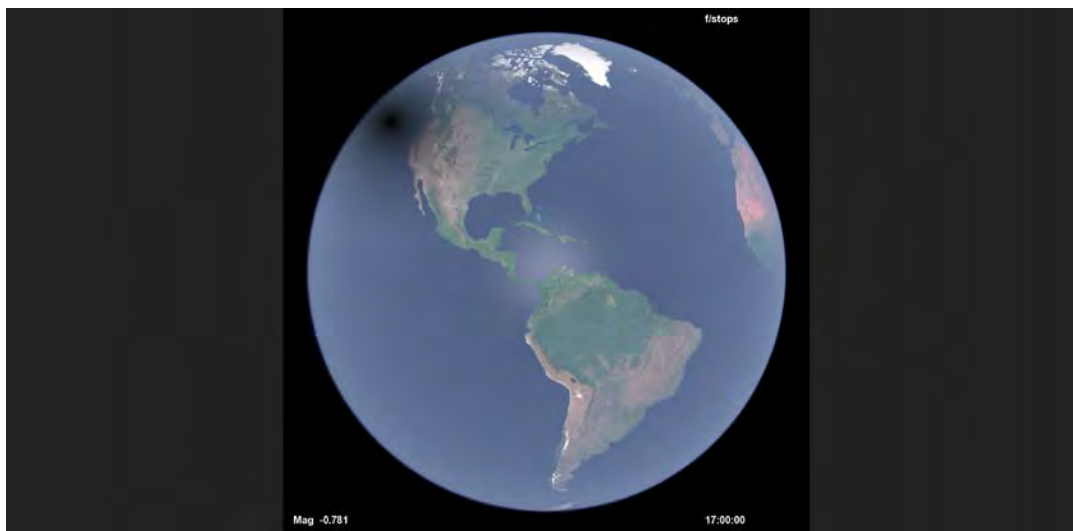

Figure 1. Simulated view of the central portion of the moon's shadow off the northwest US coastline during this summer's solar eclipse.

--Completed a project funded by the NOAA GSD Director's Directed Research Fund (DDRF) entitled "Creating High Resolution Content for the Next Generation Science On a Sphere®" with Keith Searight as Principal Investigator and Steve Albers as a Co-Investigator. This involved creating new high resolution datasets and presenting them to GSD management and staff last April using the newly installed 4K projection system in the SOS Planet Theater at the NOAA DSRC Building in Boulder.

2--Software and technical support for SOS systems

The SOS team provided regular support to SOS sites by e-mail, telephone, and occasionally in person. The issues handled included upgrades and solving problems with the SOS software, hardware, and equipment, finding and accessing datasets, and questions about operating the SOS system.

During this reporting period, new SOS systems were installed at venues worldwide including Spaceport Sheboygan (Wisconsin), Fair Oak Farms (Indiana), Kalamazoo Valley Museum (Michigan), Keesler Air Force Base (Mississippi), Santa Fe Community College (New Mexico), Yan'an Science and Technology Museum (China), Nehru Science Center (India), and The National Media Museum (England). The total number of SOS system installs worldwide now exceeds 140. The most recent estimate of the number of people worldwide that view SOS presentations is now 37M annually, a growth of over 10% from a few years ago.

In support of scientific education and outreach, portable SOS systems and SOS team members travelled to several conferences, including SciFest (Washington, DC), Earth Day (Texas), and the IUCN World Conservation Congress (Hawaii). SOS staff also led a Girls & Science program at Denver Museum of Nature and Science and facilitated webinars for the SOS community on scientific content and use of SOS

software. In the SOS Planet Theater at the NOAA DSRC building in Boulder, SOS educational shows were given to an average of 450 visitors per month, with SOS staff conducting some of the presentations or providing technical backup to presenters when needed.

3--Plan and release new SOS capabilities

Under CIRA staff's leadership, the SOS team planned and executed a major software release with many new features and capabilities. SOS v5.1 (Oct. 2016) met all planned objectives on schedule.

Major highlights are:

--Support for 4K projection systems: During the previous reporting period, the SOS software was upgraded to support 4K projectors, which display datasets on the sphere with four times the resolution as before, making the images much crisper and more detailed. However, these capabilities were developed using borrowed and incomplete equipment and during this reporting period, the SOS Planet Theater at the NOAA DSRC building in Boulder was upgraded to an operational 4K system. The SOS team used this new system to more fully test the software under 4K projection and will be better able to support other SOS sites that plan to install their own 4K systems in 2017.

--Linux operating system upgrade: SOS ran on Ubuntu Linux 12.04 LTS for many years, which reaches its end-of-support date in April 2017. The SOS software was ported to Ubuntu 16.04 LTS, which required some software changes and extensive testing. The benefit to the user community is an improved base system with higher performance and availability of up-to-date security updates for the next five years.

--Visual Playlist Editor: The initial "Preview Edition" first released with SOS v5.0 was significantly expanded to include creating and editing Presentation Playlists in addition to customized Datasets (see Figure 2). Many powerful new functionalities were added for content creators and presenters, as well as localization/translation of the user interface to non-English languages for international users.

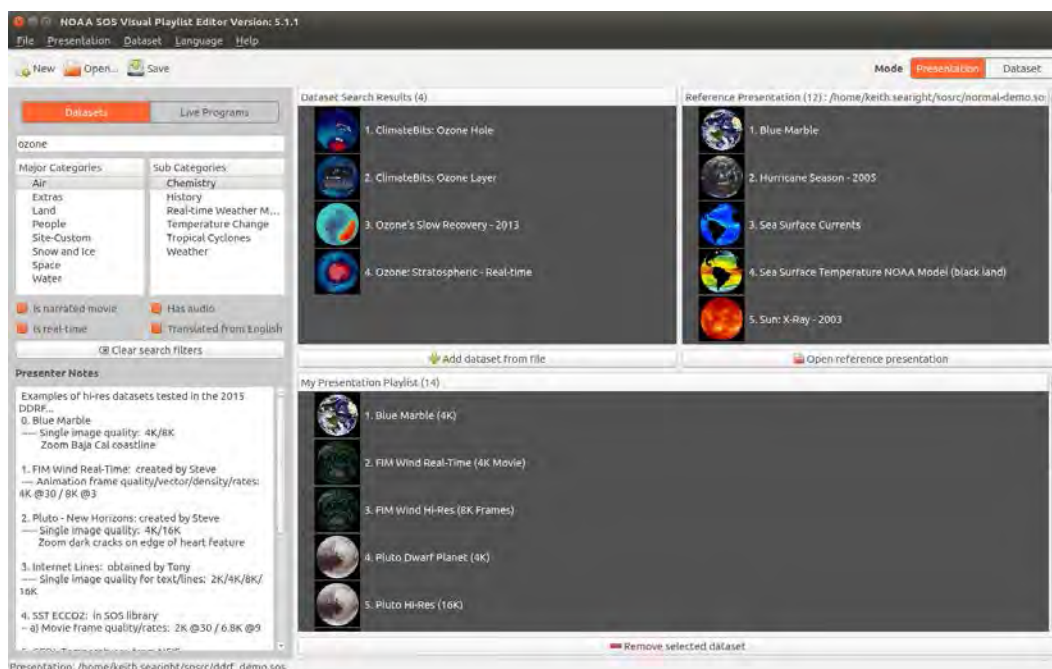

Figure 2. SOS Visual Playlist Editor, showing a presentation playlist example.

--iOS Remote App: The iPad-based controller for SOS presentations was updated with new features, including support for the latest version of iOS, much faster data catalog transfers, and displaying user-created custom overlay datasets, as well as many bug fixes.

--NOAA SOS Public Kiosk: The Windows-based touch screen public kiosk for SOS was extensively updated after its debut in SOS v5.0. Major additions included built-in file transfer functionality between the SOS and Kiosk machines, additional interface customization options, a new editor for text localization, additional options to generate trackball dataset images, enhanced sphere controls, and numerous performance and quality improvements. At least 20 SOS sites have obtained the SOS Kiosk software to-date.

--SOS Website: The project website was ported to a new Django-based infrastructure to increase reliability and improve the workflow for maintaining and adding to the web content. New features included “deep linking” into the datasets to provide persistent URLs and organizing the support information around an intuitive SOS Product Suite concept.

--New software build environment: The SOS software is compiled and deployed as an easy-to-install debian package at SOS sites. However, the existing build system’s limitations have hampered the adoption of better development practices including continuous integration, automated testing, and automated builds of complementary SOS software, including the public kiosk and visual playlist editor applications. The SOS team adopted Bazel, a popular open source build system created by Google and used it to build and deploy the SOS 5.1 release.

4--Research new technologies and configurations for future innovations in SOS

To keep SOS at the forefront of spherical display quality, both new innovations and improved performance for 4K projection were pursued. These efforts are now nearly complete and are planned for release as part of the SOS v5.2 release, scheduled for April 2017:

--Enhanced data visualization performance: With the initial release of SOS for 4K in the v5.0 release, it became clear that the existing SOS display software was not able to render high-resolution animated datasets at fast enough frame rates. So the SOS team embarked on a major rewrite of the SOS rendering engine to take advantage of the significant GPU capabilities of newer high-end graphics cards using OpenGL shader software. Initial testing of this new approach shows great promise for displaying much faster animation speeds and this innovative work will enable the SOS software to work well with increasingly high-resolution datasets into the future.

--New capabilities to display rich text: To date, SOS has had limited support for displaying text on the sphere, using either labels with a single fixed font or with images created in advance with 3rd party software like PhotoShop. Options for on-the-fly text display were researched and a solution was designed that uses HTML-based “Text PIPs” to generate virtually any text font, size, style, background color, and language. Text will be shown in a “picture-in-picture” dynamically rendered on the sphere using vector graphics, which look much sharper than raster graphics. Text PIPs will give SOS content creators many new ways to use beautiful annotations in their datasets and presentations, as well as supporting closed captioning.

PROJECT TITLE: EAR - TerraViz (also branded as SOS Explorer)

PRINCIPAL INVESTIGATOR: Sher Schranz

RESEARCH TEAM: Jeff Smith, Jebb Stewart

NOAA TECHNICAL CONTACT: John Schneider (OAR/ESRL/GSD/ATO Chief)

NOAA RESEARCH TEAM: Hilary Peddicord (CIRES), Eric Hackathorn (OAR/ESRL/GSD/ATO), Jonathan Joyce (CIRES)

PROJECT OBJECTIVES:

Our objective is to create an easy-to-use Windows and Mac application that seamlessly combines and visualizes many types of 2D and 3D environmental data across time and from the bottom of the ocean through the atmosphere and into space.

SOS Explorer™ (SOSx) uses the NOAA-developed TerraViz™ visualization engine to create an interactive Earth for the flat screen. This display can be projected on walls, computers, and large displays, providing teachers, students, and the public access to a library of selected Science On a Sphere® datasets and movies. The visualizations show information provided by satellites, ground observations and computer models and rapidly animate through real-time global data. In addition, tools included in the application allow users to zoom into, probe, and graph the data, as well as add supplementary material including websites, videos, pictures, and placemarks. In order to make the product more accessible for teachers, lesson plans and pre-programmed tours through standards-relevant topics are provided.

NOAA Earth Information System (NEIS) advances this technology further by adding more controls to allow users to dynamically add and overlay multiple data layers from different data sources and explore a full 4D volume such as the isobaric levels of meteorological forecast models. Additionally, NEIS provides the ability to access remote data from a variety of standardized services.

Support for development has been provided by Hurricane Sandy Supplemental money from NOAA, the NOAA National Environmental Satellite, Data, and Information Service (NESDIS), and the Science on a Sphere program.

PROJECT ACCOMPLISHMENTS:

Several copies of SOS Explorer have been sold to museums.

NEIS was used to support presentations for various NESDIS scientists at both the American Geophysical Union Fall Meeting 2016 in San Francisco and the American Meteorological Society Annual Meeting 2017 in Seattle, WA

Ongoing development and improvement to existing real-time research data visualization system including the following enhancements:

- Added touch screen support and support for multiple hardware configurations, including a two screen configuration for museums.
- Numerous enhancements to the user-interface, datasets supported, search capabilities, and developing more realistic shaders (to better render the Earth).
- Implemented support for calculating and animating the orbits of Earth satellites given by NORAD two-line element orbital parameters. We now have scores of satellites in orbit around the Earth, some of them with detailed 3D satellite models.

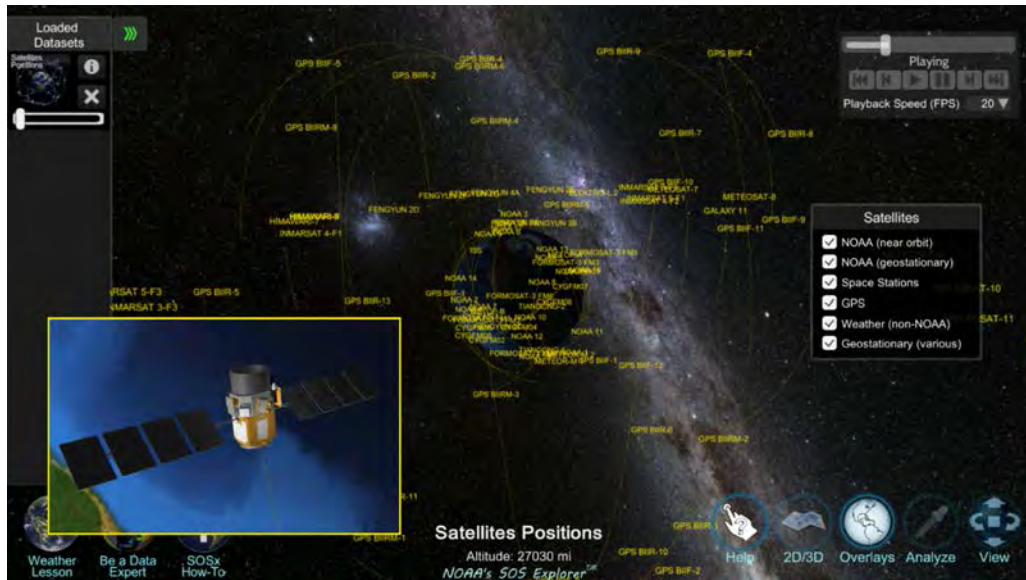

Figure 1. Satellites in SOSx

--Developed Tour Builder, a graphical user interface for creating SOSx and NEIS tours, which are outputted as files in the json format. A tour is essentially a sequence of commands or 'tour tasks' (e.g. LoadDataset, FlyTo location on Earth, display a multiple choice question, display a web page, etc.) to be executed in sequence. Tour Builder enables customers such as NESDIS or museums to develop their own tours to run either autonomously or interactively. With Tour Builder, users can drag tour tasks onto a timeline, drag to reorder them, assign information to the attributes of each tour task, and select the Play menu option to immediately preview their tour within SOSx or NEIS. Additional features include undo, duplicate, creating subtours from subsets of tour tasks, etc.



Figure 2. Tour Builder

-- Developed Dataset Editor, a graphical tool for creating new datasets for use in SOSx and NEIS. A dataset could be a sequence of images, a tiled set of images (where many tiles combine to form a high-resolution image), a real-time KML file, etc. In addition to guiding the input of standard metadata about a dataset (e.g. title, abstract, start time, end time, data format, etc.), Tour Builder enables users to define filename masks for time encoding, tile decks for high-res datasets, dataset probing information, and even

define dataset layers (for instance, a dataset might be split into multiple variables to be selected from a dropdown list).



Figure 3. Dataset Editor

-- Developed Ocean Experience, an educational game included with SOSx, that lets the user pilot a submarine launched from NOAA's Okeanos ship, explore a coral reef while avoiding damaging coral, take photographs of coral and fish (that are programmed to move in realistic ways), and also learn about coral bleaching.



Figure 4. Ocean Experience

EAR Publications:

Alcott, T., I. Jankov, C. Alexander, S. Weygandt, S. Benjamin, J. Carley, and B. T. Blake, 2017: Calibrated, probabilistic hazard forecasts from a Time-Lagged Ensemble. 33rd Conf. on Environmental Information Processing Technologies, Seattle, WA, Amer. Meteor. Soc. (Recorded Presentation available at: <https://ams.confex.com/ams/97Annual/webprogram/Paper311242.html>)

Alcott, T., C. Alexander, S. Albers, R. Ahmadov, E. James, S. Benjamin, and S. Weygandt, 2017: HRRR-AK: A High-Resolution, Rapidly Cycled Forecast Model for Alaska. 28th Conference on Weather Analysis and Forecasting/ 24th Conf. on Numerical Weather Prediction, Seattle, WA, Amer. Meteor. Soc. 615. (Available online at: <https://ams.confex.com/ams/97Annual/webprogram/Paper306923.html>)

Alexander, C., T. Alcott, I. Jankov, S. Weygandt, and S. G. Benjamin, 2017: Ensemble Prediction with the High-Resolution Rapid Refresh (HRRR): Providing Probabilistic Forecasts of Weather Hazards for Aviation. 18th Conference on Aviation, Range, and Aerospace Meteorology, Seattle, WA, Amer. Meteor. Soc. (Recorded Presentation available at: <https://ams.confex.com/ams/97Annual/webprogram/Paper313352.html>)

Beck, J., I. Jankov, H. Jiang, J.K. Wolff, M. Harrold, J. Frimel, and L. Carson, 2017: An Evaluation of Stochastic Physics Within the High Resolution Rapid Refresh (HRRR) Ensemble and the Impacts of High Performance Computing (HPC). 3rd Symposium on High Performance Computing for Weather, Water and Climate, Seattle, WA, Amer. Meteor. Soc, 1441. (Available at: <https://ams.confex.com/ams/97Annual/webprogram/Paper311904.html>)

Benjamin, S. G, S. S. Weygandt, J. M. Brown, M. Hu, C. Alexander, T. G. Smirnova, J. B. Olson, E. James, D. C. Dowell, G. A. Grell, H. Lin, S. E. Peckham, T. L. Smith, W. R. Moninger, J. Kenyon, and G. S. Manikin, 2016: A North American Hourly Assimilation and Model Forecast Cycle: The Rapid Refresh. *Mon Wea Rev*, 144, 4, 1669-1694, DOI: <http://dx.doi.org/10.1175/MWR-D-15-0242.1>

Blake, B., J. R. Carley, T. Alcott, I. Jankov, M. Pyle, and A. J. Clark, 2017: Evaluation of Several Spatial Filtering Methods for Probabilistic CPM Ensemble Forecasts. 28th Conference on Weather Analysis and Forecasting/ 24th Conf. on Numerical Weather Prediction, Seattle, WA, Amer. Meteor. Soc. 1191. (Available at: <https://ams.confex.com/ams/97Annual/webprogram/Paper313250.html>)

Govett, M, J. Rosinski, J. Middlecoff, T. Henderson, J. Lee, A. MacDonald, P. Madden, J. Schramm, and A. Duarte, 2016: Parallelization and Performance of the NIM Weather Model for CPU, GPU and MIC Processors. *Bull. Amer. Meteor. Soc.*, 98, accepted.

Harrold, M., J. Henderson, C. Holt, J. Wolff, L. Bernardet, H. Jiang, and L. Nance, 2017: Evaluation of the Grell-Freitas convective scheme within the NOAA Environmental Modeling System (NEMS)-based Global Spectral Model (GSM). 28th Conference on Weather Analysis and Forecasting/ 24th Conf. on Numerical Weather Prediction, Seattle, WA, Amer. Meteor. Soc. 602. (Available online at <https://ams.confex.com/ams/97Annual/webprogram/Paper312575.html>)

Hu, M., J. Beck, S. S. Weygandt, D. C. Dowell, S. G. Benjamin, and C. Alexander 2017: Advanced Tests of GSI Hybrid 4-D and 3-D Ensemble-Variational Data Assimilation for Rapid Refresh. 21st Conference on Integrated Observing and Assimilation Systems for the Atmosphere, Oceans, and Land Surface, Seattle, WA, Amer. Meteor. Soc. 8.2. (Recorded Presentation available at: <https://ams.confex.com/ams/97Annual/webprogram/Paper313322.html>)

Jankov, I., J. Berner, J. Beck, H. Jiang, J. Olson, G. Grell, T. Smirnova, S. Benjamin, and J. Brown, 2017: A Performance Comparison between Multiphysics and Stochastic Approaches within a North American RAP Ensemble. *Mon. Wea. Rev.*, DOI: <http://dx.doi.org/10.1175/MWR-D-16-0160.1> ,in press.

Jiang, H., G. Grell, L. Bernardet, J. Henderson, M. Harrold, C. Holt, J. Wolff, L. Carson, J-W. Bao, and J. Brown 2017: Implementation and analyzing the Grell-Freitas Convective Parameterization in The NOAA Environmental Modeling System-Based Global Spectral Model. 28th Conference on Weather Analysis and Forecasting/ 24th Conf. on Numerical Weather Prediction, Seattle, WA, Amer. Meteor. Soc. 603. (Available online at: <https://ams.confex.com/ams/97Annual/webprogram/Paper312589.html>)

Lin, H., S. S. Weygandt, S. G. Benjamin, and M. Hu, 2017: Satellite radiance data assimilation within the hourly updated Rapid Refresh. Wea. Forecasting, **32**, accepted.

Lin, H., S. S. Weygandt, A. H. N. Lim, M. Hu, J. M. Brown, S. G. Benjamin, 2017: AIRS radiance assimilation within the Rapid Refresh mesoscale model system. Wea. Forecasting, submitted.

Lin, H., S. S. Weygandt, Y. Xie, M. Hu, S. G. Benjamin, 2017: Satellite radiance assimilation enhancements for RAP version 4. Fifth AMS Symposium on the Joint Center for Satellite Data Assimilation (JCSDA), Seattle, WA, Amer. Met. Soc., 2.3. (Recorded Presentation available at: <https://ams.confex.com/ams/97Annual/webprogram/Paper313314.html>)

Shao, H., C. Zhou, M. Hu, K. M. Newman, and J. Beck, 2017: 4D EnVar Data Assimilation for the High Resolution Rapid Refresh (HRRR) System. 21st Conference on Integrated Observing and Assimilation Systems for the Atmosphere, Oceans, and Land Surface, Seattle, WA, Amer. Meteor. Soc. 8.4. (Recorded Presentation available at: <https://ams.confex.com/ams/97Annual/webprogram/Paper312697.html>)

Smith, T. L., S. S. Weygandt, C. R. Alexander, M. Hu, H. Lin and J. R. Mecikalski, 2016: Use of convective initiation information derived from GOES satellite data in the High-Resolution Rapid Refresh (HRRR) forecast system. 28th Conference on Severe Local Storms, Portland, OR, Amer. Meteor. Soc., 98. (Available online at: <https://ams.confex.com/ams/28SLS/webprogram/Paper300816.html>)

Wolff, J., I. Jankov, J. Beck, L. Carson, J. Frimel, M. Harrold, and H. Jiang, 2016: Addressing model uncertainty through stochastic parameter perturbations within the High Resolution Rapid Refresh (HRRR) ensemble. San Francisco, CA, Amer. Geophys. Union, IN33A-1801. (Available at: <https://agu.confex.com/agu/fm16/meetingapp.cgi/Home/0>)

PROJECT TITLE: Instructional Development and Learning Support for NOAA's OMAO's Chief Learning Officer (CLO), OMAO Kansas City, MO

Project Title: Instructional Development and Learning

PRINCIPAL INVESTIGATOR: Sher Schranz

RESEARCH TEAM: Jenna E. Dalton

NOAA TECHNICAL CONTACT: Scott Tessmer (NOAA/OMAO/Chief Learning Officer)

FISCAL YEAR FUNDING: \$82,125

PROJECT OBJECTIVES:

The individual in this position collaborates with the Office of Marine and Aviation Operations (OMAO) Chief Learning Officer (CLO) to develop, deliver, and administer leadership training events and learning

support with the NWSTC. They provide comprehensive on-site technical and administrative support to the OMAO CLO, including varied instructional development, educational outreach, and course support functions. They also provide a broad range of program and process support for the CLO.

PROJECT ACCOMPLISHMENTS:

LMS CLC Administration

NOAA OMAO Commerce Learning Center (CLC) Administrator supports OMAO Learning Coordinators, builds and manages course entries in the CLC, test tools and supports the transition to the new Cornerstone OnDemand (CSOD) system.

The Department of Commerce, parent organization for NOAA and OMAO, transitioned from an Oracle LMS to the Cornerstone OnDemand (CSOD) LMS. OMAO’s Chief Learning Officer, Scott Tessmer, leads OMAO’s transition as the project manager. OMAO’s highest level support positions are CLC Administrator followed by local support learning coordinators. Jenna Dalton supports OMAO as the Lead CLC Administrator providing developmental, technical, training and administrative system support.

One of the key roles for the Lead CLC Administrator during 2016/2017 has been researching and building Instructor Led Training (ILT) historic data that was missing in the transition from the previous LMS to the existing LMS. Shown below in Figure 1, several hundred courses, along with human resource coding data and subjects have been integrated and configured into the LMS. The historic data integration will continue through 2017.

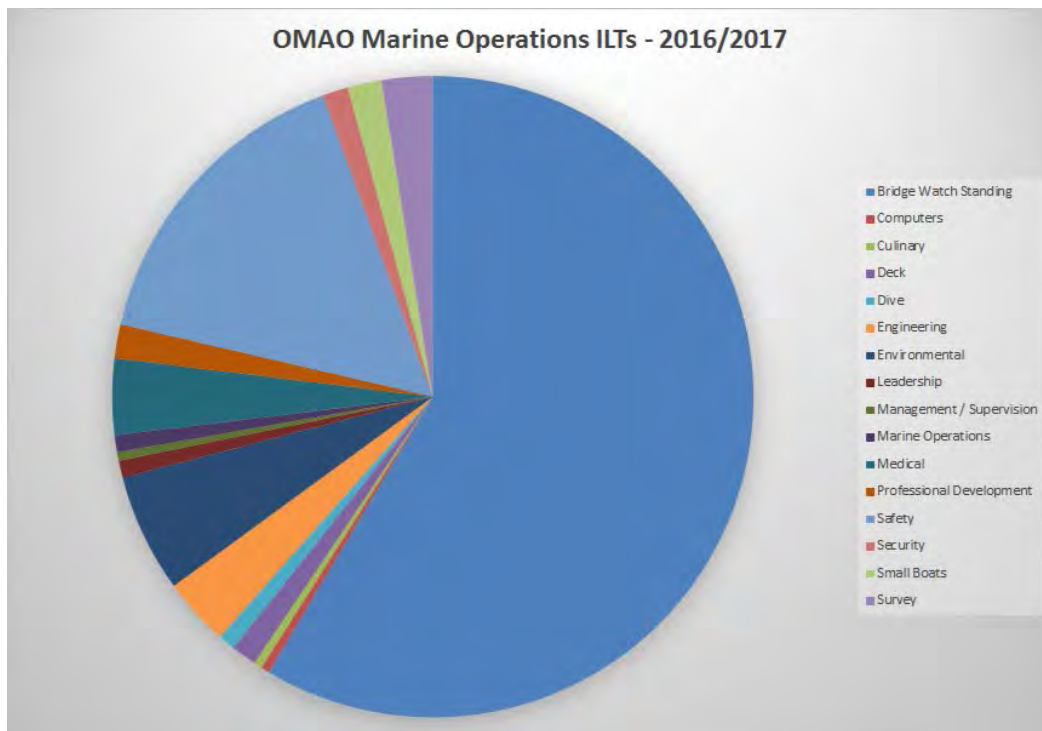

Figure 1. 2016/2017 CLC historic/gap course data implementation.

Jenna Dalton, CIRA associate trained and will continue to train a cadre of OMAO CLC learning coordinators on their new roles and specific bureau needs. The learning coordinator training will be a continuous effort by the CLC Administrator, as OMAO divisions assign the learning coordinator role to their bureau’s staff members. Below is a list of learning coordinators/admins currently trained.

Marine Ops - Co-System Administrator - Kevin Fleming
Marine Ops Resource Management - Melinda Howell
Marine Ops Environment - Julie Wagner/Brittany Anderson
NOAA Dive Center - Aitana de la Jara
Aviation Operations - David Cowan
Commissioned Personnel Center - Fionna Matheson

Reporting data from the CLC to the bureaus supervisors regarding various issues from /NOAA mandatory training to officer promotions requires a robust reporting system. CSOD allows system administrators and learning coordinators the ability to share and report vital user transcript data transparently using their Dashboard functionality, shown below in Figure 2.

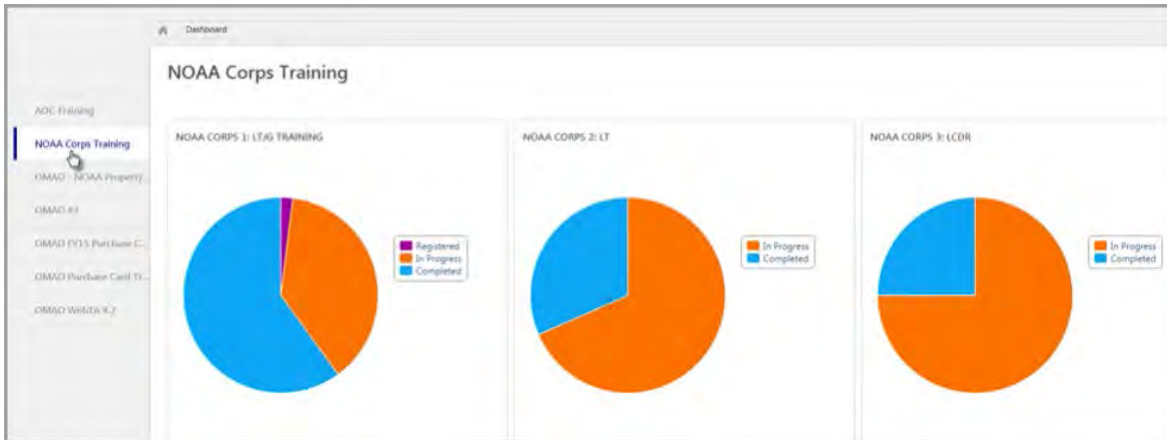

Figure 2. CSOD Dashboard Reporting.

Resource/Administrative Management

Resource management for the OMAO Chief Learning Officer (CLO) includes budget, travel, document analysis, program, administrative support and administrative support for our collaborative partnership with the National Weather Service Training Center (NWSTC).

Marine Operations Leadership Summit (MOLS) integrated two leadership conferences into one summit coordinated with the OMAO Learning Office in 2016. Scott Tessmer, OMAO CLO and Jenna Dalton, OMAO Training Specialist provided support for a productive, efficient unified summit for senior leadership (MO, OMAO, NOAA) to address the fleet leadership team all in one location and convey their vision for the future of the NOAA fleet. The summit goals to promote innovation, foster greater teamwork and collaboration in an inclusive environment was delivered alongside the OMAO Learning Office.



Figure 3. Initiative for the OMAO Marine Operations Leadership Summit 2016.

OMAO's Leadership course, Mid-Grade Week 1, fulfills the Office of Personnel Management (OPM), DOC, and NOAA requirements for new supervisor training and provides an additional cross mission development venue for the organization. This course, held at the National Weather Service Training Center (NWSTC), includes NOAA Corps Officers, waver mariners and civilian staff. CIRA associate, Jenna Dalton, supported the leadership training as the resource manager of travel and budget, director of course logistic coordination and course liaison.

Educational Collaboration

The NOAA Diving Program (NDP), is administered by the U.S. Department of Commerce, National Oceanic and Atmospheric Administration (NOAA), and is headquartered at the NOAA Diving Center in Seattle, Washington. The NOAA Diving Program trains and certifies scientists, engineers and technicians to perform the variety of tasks carried out underwater to support NOAA's mission. With more than 400 divers, NOAA has the largest complement of divers in any civilian federal agency. In addition, NOAA's reputation as a leader in diving and safety training has led to frequent requests from other governmental agencies to participate in NOAA diver training courses.

The NOAA Diving Program is in the process of redesigning their training courses and the OMAO CLO offered support resources involving instruction design and CLC administration. The Line Tended Standby Diver course, shown below in Figure 5, was originally a 30 plus minute video, without a Table of Contents, resource materials or a quiz. The OMAO CIRA associate, Jenna Dalton created a new version of this course that provides a Table of Contents, periodic knowledge checks, a quiz and an overall flow representative of user friendly online training. The goal was to build user-friendly e-learning training that could be effectively tracked in our LMS CLC. This project will continue through the next fiscal year.

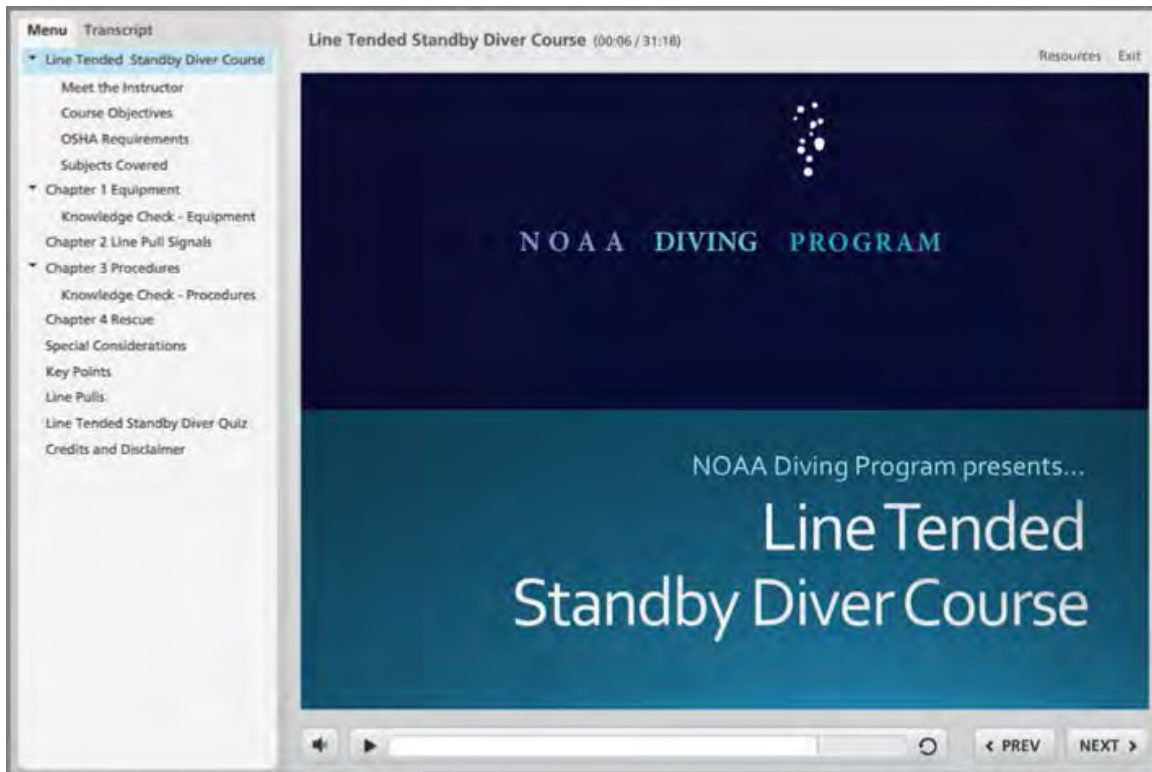

Figure 4. NOAA Diving Program's Line Tended Standby Diver Course re-design.

PROJECT TITLE: Research Collaboration at the NWS Aviation Weather Center in Support of the Aviation Weather Testbed, Aviation Weather Research Program, and the NextGen Weather Program

Project Title: International Aviation

PRINCIPAL INVESTIGATOR: Sher Schranz

RESEARCH TEAM: Jung-Hoon Kim, Robyn Tessmer

NOAA TECHNICAL CONTACT: Matt Strahan (NOAA/NWS/AWC/IOB Chief)

FISCAL YEAR FUNDING: \$1,820,298

PROJECT OBJECTIVES:

- 1--Transition GTG to GEFS ensemble, tuning to produce ensemble based probabilities of EDR.
- 2--Develop methodology for blending EDR with UKMET.
- 3--Evaluate effect of changes in model resolution and final output resolution on algorithm output.
- 4--Support GSD in acquisition and consolidation of global turbulence observation.
- 5--Document and publish algorithms and blending methodology in scientific papers and ICAO documents.

PROJECT ACCOMPLISHMENTS:

1--Transition GTG to GEFS ensemble, tuning to produce ensemble based probabilities of EDR (Accomplishment: 100%)

Worked closely with NCAR scientist to implement the Graphical Turbulence Guidance version 3 (GTG3) to NOAA's Global Ensemble Forecast System (GEFS) outputs with 1 degree x 1 degree horizontal and 50 hPa vertical grid spacings. First, multiple turbulence component diagnostics for Clear-Air Turbulence (CAT) and Mountain Wave-induced Turbulence (MWT) are calculated in all grids. Second, individual diagnostics are converted into an Eddy Dissipation Rate (EDR), which is equivalent to the ICAO standard aircraft turbulence report, making a consistent evaluation. Finally, at a given grid point of the GEFS the number of individual CAT and MWT diagnostics out of total number of diagnostics in GTG3 exceeding Moderate-Or-Greater (MOG) level EDR ($0.2 \text{ m}^{1/3} \text{ s}^{-1}$) provides probabilistic EDR-based turbulence forecast (Fig. 1). This is finally implemented to AWC Testbed (AWT) and control run of the GEFS GTG is running in-house computer resource in AWC as a real-time to support operational forecast floors in Nov 2016.

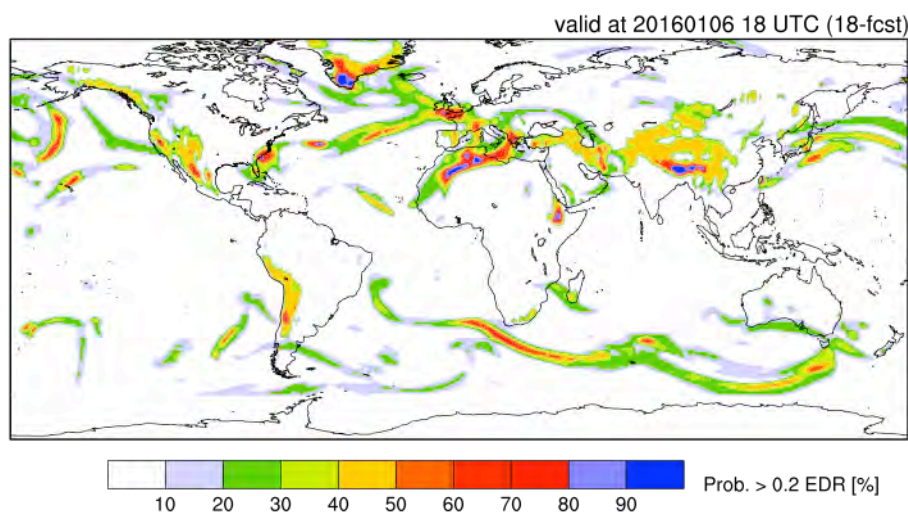

Figure 1. Global probabilistic forecast based on GTG3 GEFS at 18 UTC 6 Jan 2016.

2--Develop methodology for blending EDR with UKMET (Accomplishment: 100%)

World Area Forecast Center (WAFC) consists of WAFC Washington (NOAA/AWC) and WAFC London (UK Met Office). For better and consistent forecast product for aviation users in the world, two WAFC centers established World Area Forecast System (WAFS), which provides the blended max and mean values of turbulence grid using both NOAA's Global Forecast System (GFS) and UKMO's Unified Model (UM). In July 2016, through NOAA VSP (Visiting Science Program) we hosted UKMO scientist (B. Claire) to collaborate to develop the initial blending max and mean of EDR forecasts from newly developed global GTG on GFS and UM. First, we extracted 3D meteorological outputs from both the GFS and UM into the same grid structures (1 degree x 1 degree with 50 hPa vertical grid spacing). And then, GTG3 is applied to both GFS and UM in a same way, which produces consistent ensemble EDR-scale turbulence forecast products. Finally, the maximum and mean EDR values from the GTG GFS and GTG UM are calculated (Fig. 2), which shows that the resultant can give a consistent map of the future turbulence forecast for the users in the world.

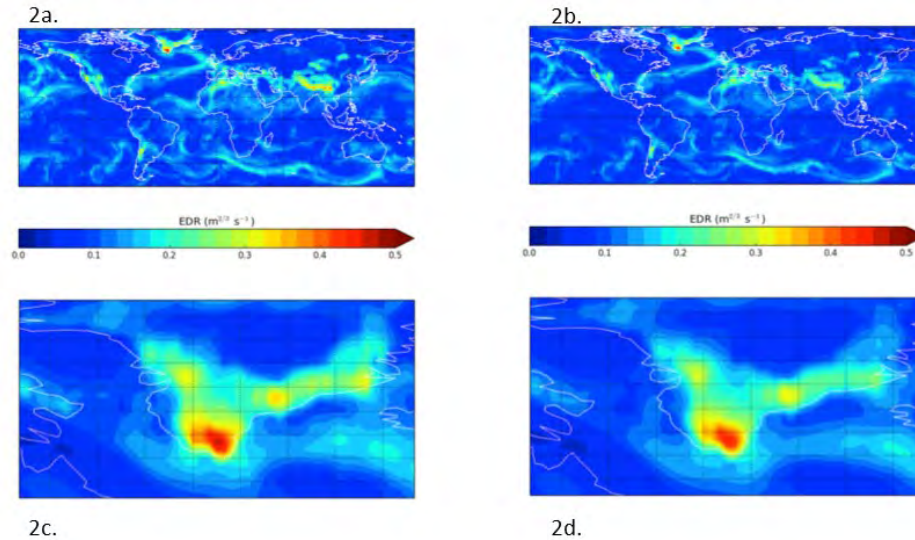

Figure 2. Global (2 a,b) and regional (2 c,d; zoomed in Greenland area) for the blended maximum (2 a,c) and mean (2 b,d) EDR from GFS GTG and UM GTG valid at 18 UTC 6 Jan 2016.

3--Evaluate effect of changes in model resolution and final output resolution on algorithm output (Accomplishment: 50%, which will be accomplished by the end of June 2017)

Calculations of component turbulence diagnostics are mostly based on horizontal and vertical gradients of wind, temperature, and other meteorological variables, which is highly dependent on horizontal and vertical grid spacings in underlying NWP model. So, currently I have archived the GFS output on 1x1, 0.5x0.5 with 50 and 25 hPa vertical grids in AWC's database, then the GTG3 will be applied to those grids to compare each other to see how the model resolution can affect the performance of the global turbulence forecast. This will be done by the end of June 2017, in accordance with the schedule of the FAA AWRP project plan.

4--Support GSD in acquisition and consolidation of global turbulence observation (Accomplishment: 100%)

For the objective evaluation of the developed GFS GTG and GEFS GTG, the global EDR observation data and current WAFS turbulence forecast data has been archived in the NOAA/AWC database since Oct 2015. I set up the internal ftp and provided the archived global EDR data and current WAFS data for GSD's Quality Assessment (QC) for the GFS GTG. I also discussed with GSD people to give a feedback for their QC. Global distributions of EDR observation above flight level 20,000 ft for null (EDR < 0.05; Fig. 3 upper) and Moderate-Or-Greater (MOG) intensity (EDR > 0.2; Fig. 3 lower) are shown in Fig. 3.

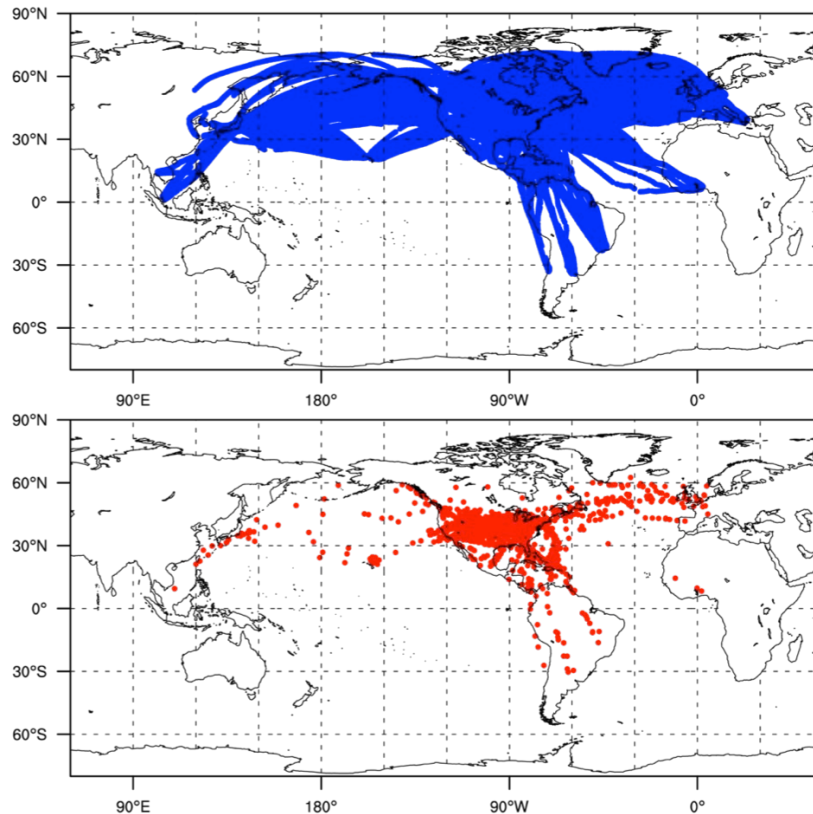

Figure 3. Global distribution for null (EDR < 0.05; upper) and MOG (EDR > 0.2; lower) EDR observation at above 20,000 ft (FL200; high level) for 1-month in October 2015, which is used for the objective evaluation of GFS GTG.

5--Document and publish algorithms and blending methodology in scientific papers and ICAO documents (Accomplishment: 100%)

First task, "Transition of GTG to GEFS", is partly documented as a paper, entitled "Global Turbulence Forecasting Techniques and Verification" by Sharman and Kim in the 18th ARAM conference in 2017 AMS annual meeting in Seattle. And, second task, "development of blending EDR method with UKMET" was presented as a paper, entitled "Inter-comparison of upper-level turbulence forecasts using GTG on GFS and UM models", in the 18th ARAM conference in 2017 AMS annual meeting in Seattle. External collaboration with NASA for "application of aviation turbulence information to Air-Traffic Management" is finally published in the book "Aviation Turbulence: Processes, Detection, Prediction" in July 2016. Joint collaboration with NCAR scientists for "update of upper-level turbulence forecast by reducing unphysical components of topography in NWP model" is finally published in GRL in July 2016. This is extended to use hybrid vertical coordinate in WRF model, which is also presented in 18th ARAM conference in Jan 2017. For outreach, I also attended ICAO IATA users meeting held by Delta Headquarter in Atlanta, GA in Jul 2016 to present "Global wind and turbulence forecast for optimizing flight plan routing". I also gave a talk about "AWC Ensemble Requirements and Ensemble-based Global Aviation Turbulence Forecasting Techniques and Verifications" in the 5th NCEP ensemble workshop in Washington DC, in Jun 2016. I did two special seminars at CSU/CIRA in Fort Collins, and at NOAA/ESRL in Boulder, in Aug 2016. I was also invited to the Fifth Workshop in Aviation Meteorology in Jeju, South Korea in Nov 2016. Finally, I was invited to be a reviewer for several peer-reviewed AMS journal papers like Journal of Applied Meteorology, Weather and Forecasting, Monthly Weather Review, and Bulletin of American Meteorological Society during this fiscal year.

PROJECT TITLE: Research Collaboration at the NWS Aviation Weather Center in Support of the Aviation Weather Testbed, Aviation Weather Research Program, and the NextGen Weather Program

PRINCIPAL INVESTIGATOR: Sher Schranz

RESEARCH TEAM: Daniel Vietor, Larry Greenwood, Adrian Noland, Brian Pettegrew, Bret Lucas, Robyn Tessmer

NOAA TECHNICAL CONTACT: Clinton Wallace (NOAA/NWS/AWC), Joshua Scheck (NOAA/NWS/AWC)

NOAA RESEARCH TEAM: Steven A. Lack (NOAA/NWS/AWC), Austin Cross (NOAA/NWS/AWC)

PROJECT OBJECTIVES:

The Aviation Weather Center (AWC) Aviation Support Branch (ASB) is responsible for providing support to the research and operations processes, maintaining server and networking infrastructure, and supporting the www.aviationweather.gov website.

The primary goal of the ASB is to maintain the internal network, servers and workstations at the AWC to ensure continuity of operations. The 24x7 support is critical to AWC forecast and web operations. The ASB collaborates with the other National Center for Environmental Prediction (NCEP) centers and the National Weather Service (NWS) to provide data and research to operations support. The branch supports the research operations at the AWC, headed by a team of Technique Development Meteorologists (TDMs). This includes support for the Testbed (AWT) as well as support for AWRP. The AWRP products include Current and Forecast Icing Products (CIP/FIP), Graphical Turbulence Guidance (GTG), National Ceiling and Visibility Analysis (NCVA), and the National Convective Weather Diagnostic/Forecast (NCWD/F). The ASB also supports the AWC website which includes Aviation Digital Display Service (ADDS), World Area Forecast System (WAFS) Internet File service (WIFS) and the International Flight Folder Program (IFFDP).

As part of the CIRA effort, the ASB has close links to the research and development projects going on at the AWC. This includes:

- Supporting NextGen and AWRP,
- Providing better tools to decrease weather impacts to the National Airspace System (NAS) including efforts at the FAA Command Center and with the Traffic Flow Management (TFM) project,
- Providing direct support to the TDMs at the AWC for ongoing research projects including GOES-R, ensemble model diagnostics and product verification,
- Expanding its collaboration efforts with the other testbeds within NOAA and the NWS focusing on R2O projects.

PROJECT ACCOMPLISHMENTS:

In the past year, efforts have been centered on five primary projects:

- 1--GFA tool
- 2--Impacts TAF Board
- 3--TFM Convective Forecast
- 4--Upgrades of servers for AWRP production (CIP, FIP, NCVA, NCWD/F)
- 5--Gate Forecast edit capability

Graphical Forecast for Aviation (GFA) Tool

The first version of the GFA Tool was put on the testbed website in January 2016. Initial user feedback was very positive and led to several changes to the user interface as well as the data presented. Work continued on the user interface throughout the summer, with an emphasis to make it more intuitive. Each update was made available on the testbed website. The biggest change to the tool was the separating of

the observational displays from the forecast displays. Other changes included a new time slider interface and extended settings page (see Figure 1). The final layout includes the following displays:

Forecasts:

- TAFs: TAFs with NWS Warnings
- Ceiling and Visibility: Graphical AIRMETs (G-AIRMET) IFR advisories, NDFD weather point forecasts, LAMP flight category forecasts
- Clouds: G-AIRMET mountain obscuration advisories, RAP cloud base, tops and fraction forecasts, Point cloud layer queries
- Precipitation and Weather: Convective SIGMETs, NDFD weather forecast imagery and point forecasts
- Thunderstorms: Convective SIGMETs, NWS Warnings (tornado and severe thunderstorm), NDFD convective forecast imagery and NDFD weather point forecasts
- Winds: RAP forecasted wind speed imagery and point wind forecasts (wind barbs), NDFD surface winds, G-AIRMET low level wind shear and strong surface wind advisories
- Turbulence: Turbulence SIGMETs, G-AIRMET turbulence advisories, GTG forecasts
- Icing: Icing SIGMETs, G-AIRMET icing advisories, FIP icing severity forecasts

Observations:

- METARs: Satellite and radar, METARs, SIGMETs, NWS Warnings
- Precipitation: Satellite and radar, METAR weather symbols, Convective SIGMETs
- Ceiling and Visibility: Satellite and radar, SIGMETs, Flight category point information
- PIREPs: Satellite and radar, SIGMETs, PIREPs
- Radar and Satellite: Satellite and radar, SIGMETs, NWS Warnings

The settings menu was replaced with a single settings page, allowing the user to select weather layers to display, opacity, plot density and scaling, data age, type of radar and satellite, basemap type and other overlays such as airports, navigational aids, airspace regions, and ARTCC boundaries. The final layout can be seen in Figure 1.

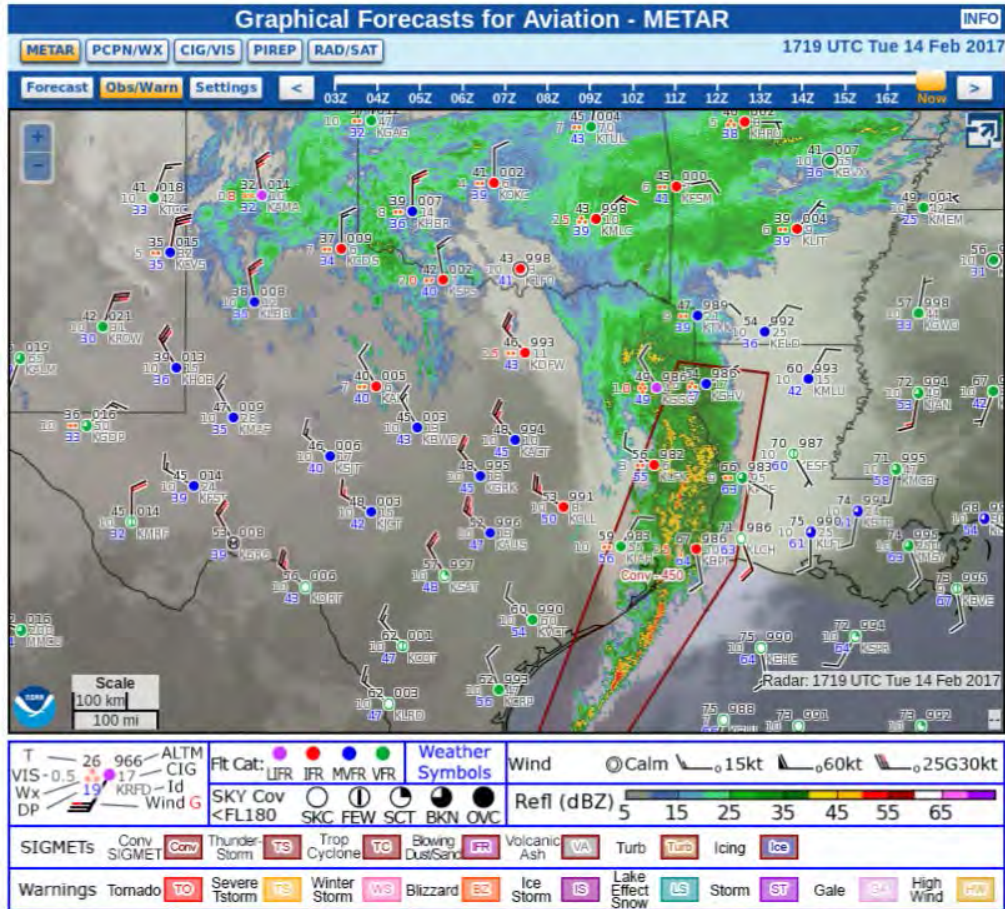

Figure 1. The production version of the GFA Tool.

A major effort over the spring and summer of 2016 was to create point forecasts of cloud layers. For consistency with the other displays, the RAP model was used for this implementation. The algorithm uses several components of the RAP output including specific humidity, cloud water mixing ratio and cloud ice to determine the location of clouds in a column. Then an estimate of cloud fraction is determined for each cloud layer. The output shows cloud base and coverage for each layer, cloud tops for clouds below 18,000' (See Figure 2). If the clouds extend above 18,000', they will be listed as cirrus above. The output currently is only in height above mean sea level (MSL) but conversion to above ground level is being investigated.

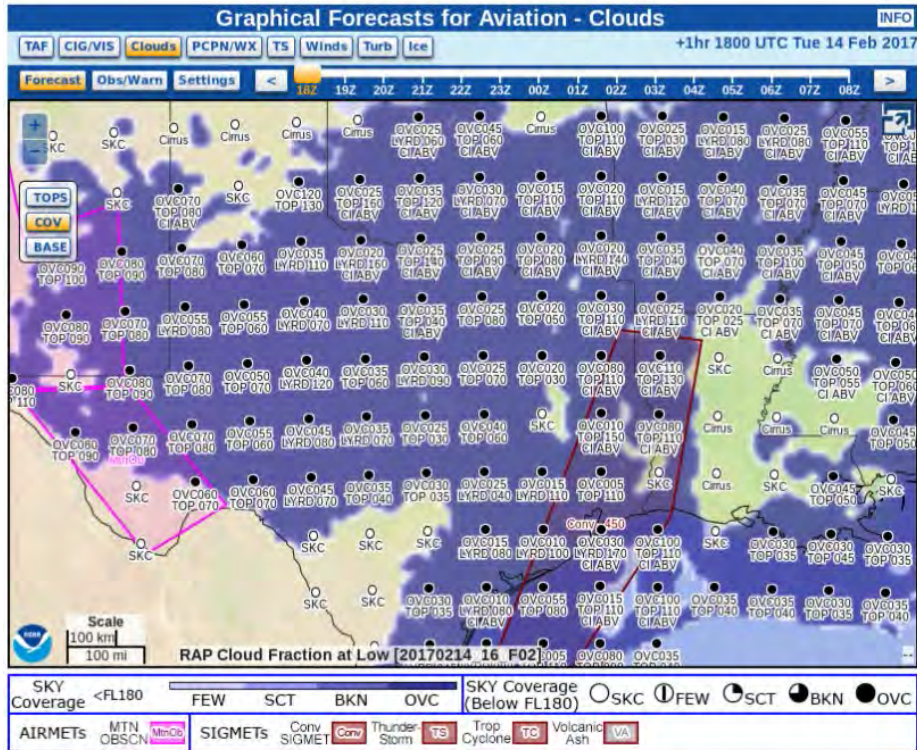

Figure 2. GFA Tool point cloud layer information from the RAP Model.

One more emphasis of the tool is to add enough navigation information so a pilot can see the weather relative to VORs, fixes, airports and airway locations. Each navigation location has an on-click pop-up for additional information such as VOR frequencies and a multitude of information for each airport including elevation, use (public, private, etc.), number of runways, longest runway length, runway type (concrete, asphalt, grass), airport services, tower setup and rotating beacon daily availability. This is all available in the FAA's Facility Aeronautical Data Distribution System (FADDS) database which is updated every 56 days. An example of the navigational data is in Figure 3.

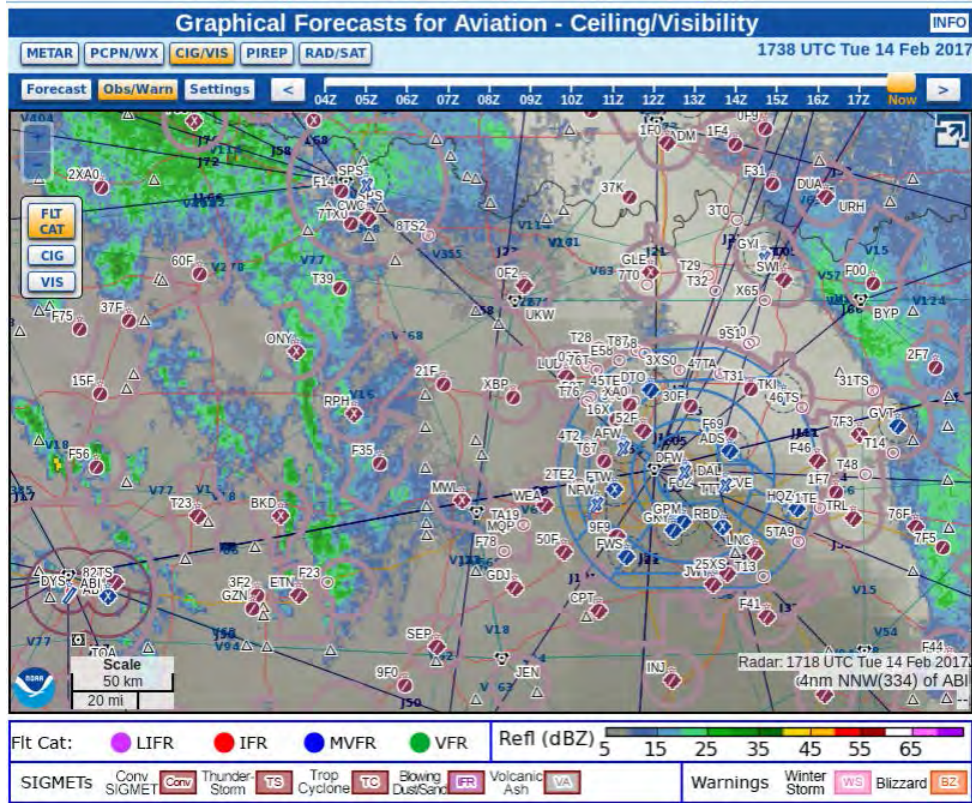

Figure 3. GFA Tool navigation information with radar.

Work on the user interface was completed in September and work on help pages, tutorials continued through October and November. The move of the support code to production was done in December. The GFA Tool went into production on December 15 and user feedback continues to be very positive.

Impacts TAF Board

The TAF Board is a spreadsheet view of the Terminal Aerodrome Forecast. The columns show forecasts progressing through time and the rows are forecasts for individual airports. This is meant for situational awareness of weather conditions that might significantly impact commercial air traffic in and out of top airports. Initially, the TAF Board used standard flight category (VFR, MVFR, IFR, LIFR) criteria but these criteria are not useful for commercial traffic. Also, since weather conditions impact airports in different ways, the National Aviation Meteorologists (NAMs) at the FAA Command Center in Warrenton VA came up with an "impacts catalog" that outputs a risk based on a combination of ceiling, visibility, weather and winds for each of the top airports. In other words, weather conditions that could curtail traffic in Atlanta could be different from weather in Denver. The TAF board then color codes the times of potential impacts as slight (yellow), moderate (orange) or high (red) and lists the weather condition creating that impact (see Figure 4).

Impacts TAF Board														
IDs: @TOPC		Submit												
Potential Impact		None	Slight	Moderate	High	Updated at: 0600 UTC 20 Feb 2017								
Time	OBS	20/06Z	20/07Z	20/08Z	20/09Z	20/10Z	20/11Z	20/12Z	20/13Z	20/14Z	20/15Z	20/16Z	20/17Z	20/18Z
@TOPC														
KMSP											WX	[WX]	[WX]	[WX]
KDTW														
KORD							[VIS]	[VIS]	[VIS]	[VIS]				
KMDW							[VIS]	[VIS]	[VIS]	[VIS]				
KCVG		[VIS]	[VIS]	VIS	VIS	VIS	VIS	VIS	VIS	VIS				
KSTL														
KMEM					[VIS]	[VIS]	[VIS]	[VIS]						
KDFW		[WX]	[WX]	[WX]										
KIAH	CIG	[VIS]	[VIS]	[VIS]	WX	[WX]	[WX]	[WX]	[WX]	WX	WX	WX	WX	WX
Time	OBS	20/06Z	20/07Z	20/08Z	20/09Z	20/10Z	20/11Z	20/12Z	20/13Z	20/14Z	20/15Z	20/16Z	20/17Z	20/18Z

NOTE: TEMPO conditions in [brackets]. Keep in mind TEMPO conditions might be better (lower impact) than prevailing conditions.

Figure 4. Impacts TAF Board summary page.

If the user hovers over the time, a pop-up with more information will appear including impact from each weather parameter. This gives the air traffic forecaster a heads up as to when significant weather will occur and what will be the impact.

For more information, a detailed airport specific view, can be selected. This gives specific weather information decoded from the TAF in a tabular form (see Figure 5). Each row is a weather phenomenon decoded from the TAF. Prevailing conditions are shown but if there are temporary conditions, they'll be shown in brackets [WX]. Each phenomenon is color coded to the impacts catalog and in some cases more than one phenomenon can have an impact.

The Impacts TAF Board went operational on November 28, 2016. Additional work to refine the impacts criteria continues as more information related to weather impacts are defined.

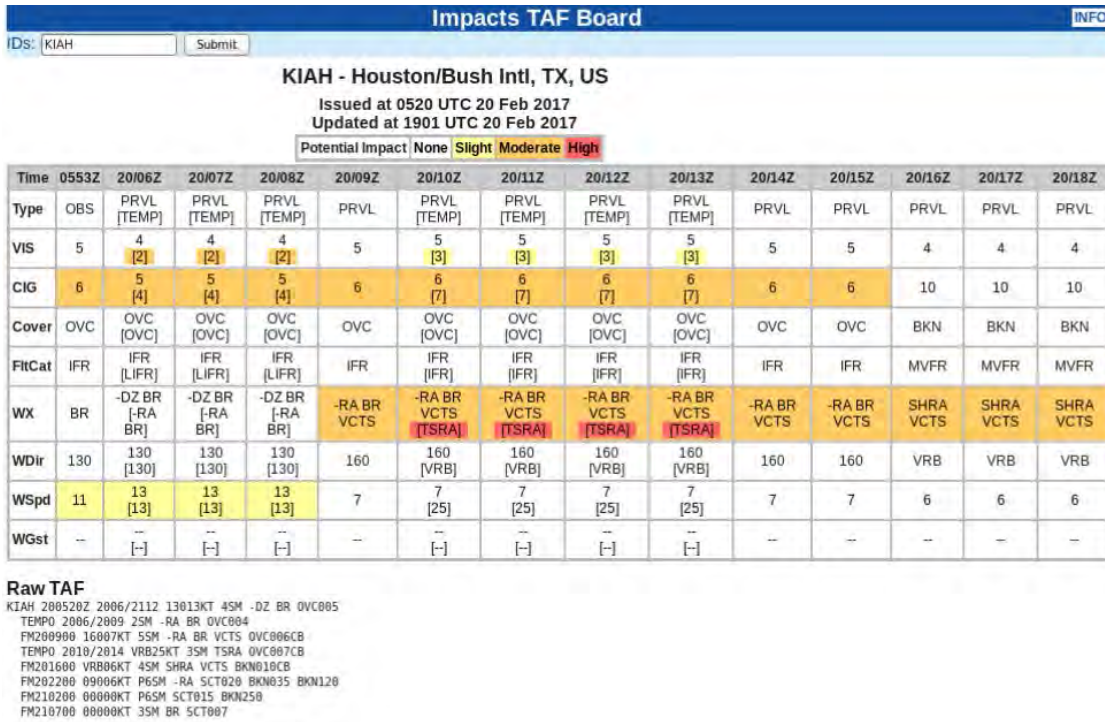

Figure 5. Impacts TAF Board site page.

TFM Convective Forecast (TCF)

The web group is providing support for a new product at the AWC called the TFM Convective Forecast. This replaces the CDM Convective Forecast Planning product (CCFP) and the Collaborative Aviation Weather Statement (CAWS). The CCFP product was an automated forecast from a variety of models showing areas of convection that could affect aviation. The CAWS was a collaborative product aimed at specific hazards to traffic flow.

The TCF product has a winter/off-season (November to February) mode which is automated, and an on-season (March to October) mode where forecasters start with an automated product, augment it to create a preliminary forecast, use a chat whiteboard for input from stakeholders, and end with a final collaborative product (see Figure 6).



Figure 6. TFM Convective Forecast.

The TCF has a web interface that allows collaborators access to a preview product prior to the opening of the chat whiteboard. What's different with this product is that the preliminary data is not accessible by the public, thus requiring user authentication. This was built into the preview page. The TCF product went live on February 15, 2017.

Aviation Weather Research Program (AWRP) update

AWRP had two sub-projects: moving of the AWRP algorithms to new environments and updates to the Helicopter and Emergency Medical Services (HEMS) Tool. The existing aviation specific algorithms that produce official NWS forecasts for display on the website are being migrated to new homes in order to provide more substantial support and more efficient transitions into operations for new products. This migration is broken down into two phases.

The first phase was to move algorithms that are still run on AWC hardware to updated computing systems. The first product was an upgraded version of the Current and Forecast Icing Products (CIP/FIP) in February 2016. Previous versions had been run on an aging operating system (Redhat Enterprise Linux version 5) and were degrading the resolution to support aging web display software. The new software was installed onto an updated virtual machine and run at the native resolution. The web tool was updated to properly decode and display the data as well. The second product was the National Ceiling and Visibility Analysis (NCVA) product, which runs every 5 minutes and supports both ADDS and the HEMS tool. This was also migrated from outdated hardware to a more stable virtual environment with an updated operating system. The code was re-built onto the new system and provided with an updated station table to provide better interpolation. Finally, the processing for the National Convective Weather Diagnostic/Forecast (NCWD/F) was moved to the new environment. This product did not require a rebuild, but the operational partition was moved to the new virtual environment with supported legacy libraries.

The second phase is to plan for more efficient research-to-operations to our national infrastructure. After the implementation of GTG3 onto the national supercomputer, WCOSS, AWC began working with NCAR developers for the transition of the CIP/FIP products to the same platform. An initial FIP run was installed and developmentally run on the WCOSS developmental space and is currently in review to meet NCO standards. Additionally, AWC hosted a meeting between external product developers, the FAA, and other partners within NOAA to discuss the upgrade in efficiency to moving these algorithms to a more

stable post processing platform that will provide a number of advantages. This will increase cooperation between NWS national centers, AWC, and EMC and allow for more diverse access of numerical models to these aviation derivations.

The experimental HEMS Tool had two new sources of data added for evaluation. The first data set was the ceiling and visibility data from the Localized Aviation MOS Product (LAMP). This provides medium resolution output as an analysis but also adds forecast data the NCVA couldn't produce. The second data set was surface observations from the Meteorological Assimilation Data Ingest System (MADIS). This adds about 5000 more hourly observations to the HEMS Tool. Even though most of these observations don't include cloud and visibility data, they are still helpful in overall situational awareness. Also, work began on designing a new user interface for HEMS that would mimic the GFA Tool. A Meeting with the US Helicopter Safety Team (USHST) was held in February 2017 and a user survey was set up to ensure proper feedback in the new design as well as evaluation of new data incorporated into the tool.

Traffic Flow Management (TFM) project update

There are two main projects under TFM: The Impacts TAF Board and the Gate Forecasts. Work on the Impacts catalog continues as stated above. Most of the work on the Gate Forecasts centered on the user edit functionality. The Gate Forecasts show aerial impact from thunderstorms within either an arrival or departure gate. As of now, the algorithm uses a three-hour time lagged ensemble composite reflectivity from the High Resolution Rapid Refresh (HRRR) Model. If thunderstorms cover enough of the gate, it will be colored yellow. If strong thunderstorms cover enough of the gate, it will be colored red. The page shows roughly nine hours of forecasted impacts for up to four departure and four arrival gates (see Figure 7).

Verification of the gate forecasts is being done at NOAA GSD. The forecast data are provided through an interface on the production website and is verified through applying the algorithm to Multi-Radar Multi-Sensor (MRMS) radar data. Evaluation of the forecasts in areas like Denver, where mountain thunderstorm activity is under-represented by the forecast algorithm, and Miami where coastal land-sea breeze thunderstorms are not properly captured, is under way. It is essential that in areas where the algorithm under-performs, forecaster correction is done.

The Gate Forecast Edit Tool will allow a local forecaster to edit the gate forecast as they see fit, especially if the model algorithm is not capturing the location and timing of the thunderstorm activity correctly. The edit tool will allow a forecaster to edit any of the gate forecasts for a specific airport and provides plots of the time lagged HRRR data as possible input. If a forecaster edits a gate forecast, their name (as in "ztl" in Figure 7) will appear in the "Run" column of the pop-up display reflecting that the forecast has been updated.

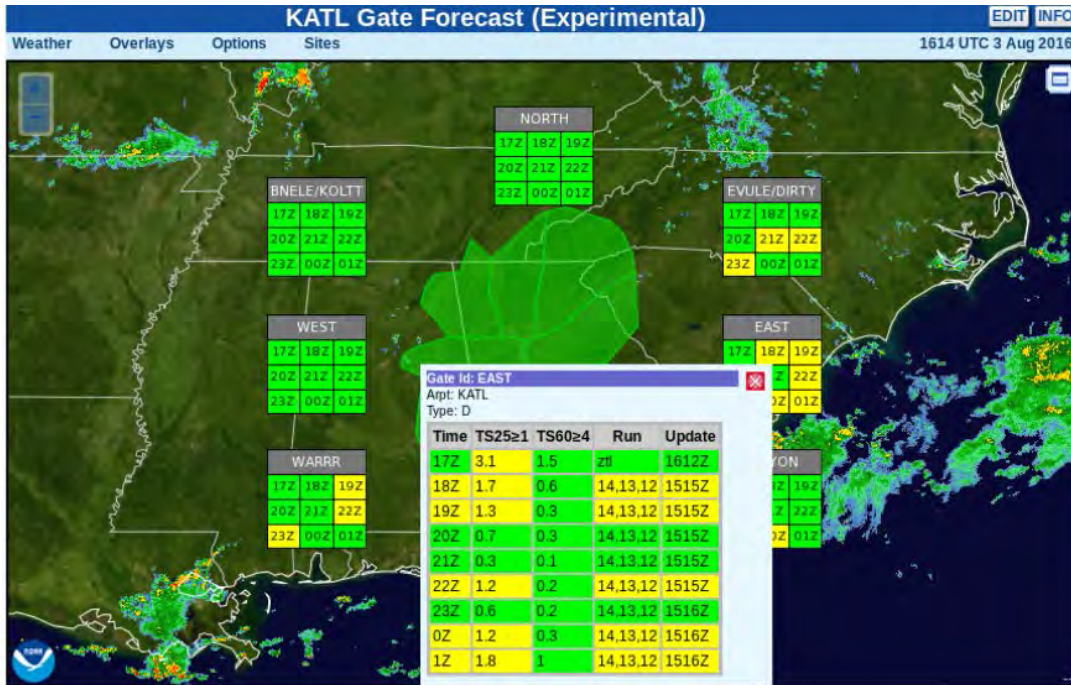

Figure 7. Gate Forecast for Atlanta showing upcoming thunderstorm impact to several of the gates.

The gate forecast edit capability is currently being tested for a spring release.

Other Accomplishments

--New User Authentication Setup - A new more streamlined user authentication process was implemented in early 2017 to address issues with user authentication and access control. Fixes to the user registration process, including email confirmation, were also done.

--PIREP Submit Updates - After the PIREP Submit Tool became operational in June 2016, user feedback on how to improve the tool came in. The Airline Owners and Pilots Association (AOPA) headed an effort to prioritize upgrades to the tool. Last fall, work proceeded on several of those recommended changes including better quality checking of input data and a more streamlined user interface. These updates are scheduled for March or April of 2017.

--WAFS Experimental Page - Work to replace the WAFS global icing and turbulence grids continue. There has been a need to show these data for public evaluation. A new testbed page has been created to show the new experimental global data (see Figure 8).

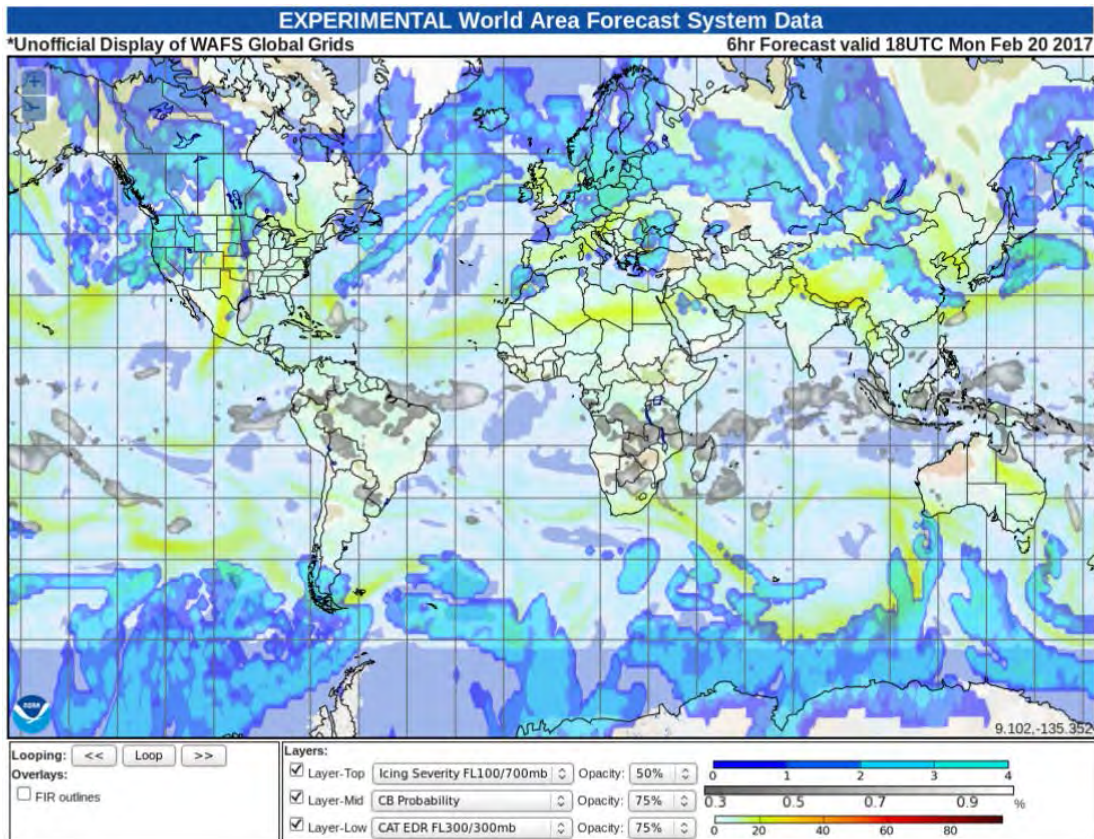

Figure 8. Experimental WAFS turbulence and icing data

--Lightning Data - Continue efforts to develop a wide range of newly derived products from surface lightning detection networks and satellite based Global Lightning Mapping (GLM). Intensification and decay of thunderstorms can be observed more astutely using total lightning along with derived echo top products from total lightning data. Assessment of these new products is being done in the testbed.

PROJECT TITLE: Research Collaboration at the NWS Aviation Weather Center in Support of the Aviation Weather Testbed, Aviation Weather Research Program, and the NextGen Weather Program.

PRINCIPAL INVESTIGATOR: Sher Schranz

RESEARCH TEAM: Lee Powell, Mick Ohrberg, Bret Sorensen, Robyn Tessmer

NOAA TECHNICAL CONTACT: Joshua Scheck (NOAA/NWS/AWC/ASB Chief)

NOAA RESEARCH TEAM: Steven A. Lack (NOAA/NWS/AWC)

PROJECT OBJECTIVES:

This research team is responsible for AWC's ground based satellite field and datacenter infrastructure with a primary mission of providing hardware platforms, virtual resources, technical expertise, and growth

opportunities for research being done by fellow CIRA representatives in close collaboration with Federal liaisons. This three-person team is known as the Datacenter Team to AWC. Geographically, responsibilities include the primary datacenter at AWC in Kansas City, MO and the growing footprint at the FAA's Air Traffic Control System Command Center (ATCSCC) in Warrenton, VA. This team also supports disaster recovery exercises and facilities at Scott and Offutt Air Force Bases. Ultimately this unit's impact is realized when scientific improvements and breakthroughs are implemented in aviation weather prediction models. The Datacenter Team is very involved in a product's successful transition through the many research phases into AWC's Operations. The research to operations process is an intense procedure that leverages features and capabilities found in AWC's Aviation Weather Research Program (AWRP) including the Aviation Weather Testbed (AWT) and the center's web services platform.

The AWT at the AWC provides the infrastructure and facilities to develop, test, and evaluate new and emerging scientific techniques, products and services. The Datacenter Team falls into AWC's Aviation Support Branch (ASB) which collaborates with the other National Center for Environmental Prediction (NCEP) centers and the National Weather Service (NWS) to provide data and research for operational support. The (AWRP) products include Current and Forecasted Icing Products (CIP, FIP) and Graphical Turbulence Guidance (GTG). The ASB also supports AWC's web services which include the Aviation Digital Data Service (ADDS), the World Area Forecast System (WAFS) Internet File service (WIFS) and the International Flight Folder Document Program (IFFDP).

Milestones and projects shift yearly allowing the Datacenter Team to focus on specific areas of the IT infrastructure. This delivers modern IT management capabilities and standards-based infrastructure to reduce cost and increase efficiency. These projects along with milestones are set and monitored by the CIRA personnel and AWC to ensure objectives are achieved in a timely fashion each year. The center utilizes quad charts weekly to visualize progress toward a goal and to highlight areas where more attention is needed. Yearly objectives do not always account for side projects or smaller research endeavors that may arise during the year. For the timeframe of April 1, 2016 – March 31, 2017 the team set the following goals:

Milestone	Completed in Quarter
Access to view rule base of the firewalls that protect the boundary	2
Provide compute platform for the AWT Winter Experiment	2
Transition of GTG3 to WCOSS platform	2
DMZ Migration to VMs	2
Restructure AWIDS (Remove operational functions)	2
DEV Migration to VMs	2
Implement control process for removable media	3
Consolidate system inventory	3
Virtual Machine environment scanned with credentials	3
Backup media transported to an alternate storage location	3
Support the All Aviation Hazards CAWS within the AWT	3
RHEL5 to RHEL6 Migration	3
Completion NOAA8861 FY16 A&A	3
Increase in bandwidth at the ATCSCC	4
Provide compute platform for the AWT Summer Experiment	4
OPS Migration to VMs	4
Virtualization of AWT Remote Center Testbed (RCT) System	4
Acquisition of at least one new ensemble model datasets	4
AWC products in a WXXM format	4
Establish an AWC development effort in VLAB	4

PROJECT ACCOMPLISHMENTS:

As noted in the second column milestones were met through the year with a high degree of success. Large projects outside the objectives for this year included a complete tear down of the largest conference room and deployment of a full enterprise filer with a suite of virtualization hosts at the Air Traffic Control System Command Center (ATCSCC) in concert with bandwidth upgrades.

The conference room rebuild project transitioned the room from a barely functional meeting space to a highly versatile innovative workspace able to support development and research. The CIRA datacenter team listened to the needs of AWC and CIRA staff, then worked with leadership to arrive at a very functional and highly versatile room. Thirty network connections, power for forty workstations, a full audio/visual upgrade to include automation with dynamic source to destination displays and windows were added to the room. The improvements created a space where forecasters and CIRA research staff can collaborate on ideas that lead to better integration and tool development. Audio/visual features now support extending testbed displays and systems to the conference room, effectively doubling the AWT footprint if necessary. This opens the door for larger bi-annual experiments the AWC is well known for. The room has cameras and microphones to allow outside and off-site collaboration with scientists,

researchers and civilian personnel extending the opportunity for scientific growth and awareness of the CIRA/AWC integrated mission.

CIRA and the AWC have a long history of collaboration with the FAA. This year the footprint at the ATCSCC was substantially improved. We deployed an enterprise NetApp file server with 130 terabytes of available storage (Figure 1). This along with vSphere servers and Cisco switching hardware allows a miniature AWC to be deployed to the forecasters at the command center. Ensuring they have the latest research and development tools to provide on the spot advice to the FAA. This effort coincided with a network circuit upgrade from 6 Mbps to 45 Mbps. The CIRA datacenter team was instrumental in the architecture of the hardware and network infrastructure to successfully deploy this equipment. (Figure 2)



Figure 1. Rack of equipment deployed to the ATCSCC.

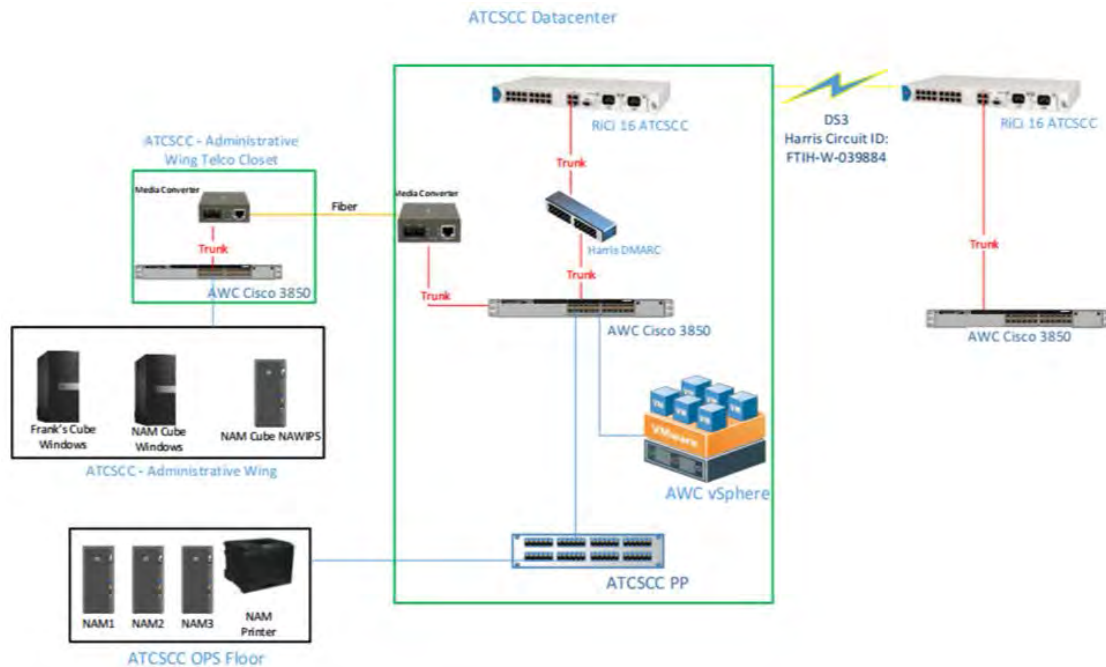

Figure 2. New connection for development and testing experimental processes with the FAA.

Other accomplishments and contributions are as follows:

- Because of the new conference room we were able to host a 26 person Git training for not only AWC, but the entire building. This also leveraged our VDI solution.
- Decommissioned excess inventory totaling \$640,000.
- Developed and deployed digital signage within the AWC section of the building.
- Deployed new enterprise file server for development, a NetApp 8040
- Migrated from vSphere 5.5 to 6u2 and moved all VM's to new 8040 SSD file server.
- Re-architected the SQL server environment on Windows and Linux.

Publications:

Chun, H., J. Kim, D. Lee, S. Kim, M. Strahan, B. Pettegrew, P. Gill, P. Williams, U. Schumann, J. Tenenbaum, Y. Lee, H. Choi, I. Song, Y. Park, and R. Sharman, 2017: Research Collaborations for Better Predictions of Aviation Weather Hazards. Bull. Amer. Meteor. Soc. doi:10.1175/BAMS-D-17-0010.1, in press.

Claire B., J.H. Kim, J. C. H. Cheung, P. Buchanan, M. Strahan, J. W. Scheck, and R. D. Sharman, 2017: Inter-comparison of Upper-level Turbulence Forecasts using Graphical Turbulence Guidance (GTG) on GFS and UM models. 18th Conference on Aviation, Range, and Aerospace Meteorology (ARAM), Seattle, WA, Amer. Meteor. Soc., 4.6. (Recorded Presentation available at: <https://ams.confex.com/ams/97Annual/webprogram/Paper309316.html>)

Kim, J.H., S.-H. Park, R. D. Sharman, and J. Klemp, 2017: Updates of Upper-Level Turbulence Forecasts by Reducing Unphysical Topography with Hybrid Vertical Coordinate in WRF Model. 18th Conference on Aviation, Range, and Aerospace Meteorology (ARAM), Seattle, WA, Amer. Meteor. Soc., 5.1. (Recorded Presentation available at: <https://ams.confex.com/ams/97Annual/webprogram/Paper308353.html>)

Kim, J., W. N. Chan, and B. Sridhar, 2016: Application of Aviation Turbulence Information to Air-Traffic Management (ATM). Aviation Turbulence: Processes, Detection, Prediction, R. Sharman and T. Lane, Ed., Springer International Publishing, 481–500.

Lack, S. A., B. R. J. Schwedler, A. Cross, A. M. Terborg, J.H. Kim, B. P. Pettegrew, R. A. Walton, S. Silberberg, R. L. Solomon, C. B. Entwistle, J. W. Scheck, and T. P. Mahony, 2017: Overview of the 2016 Winter and Summer Aviation Weather Testbed Experiments. 7th Conference on Transition of Research to Operations (TRO), Seattle, WA, Amer. Meteor. Soc., 879. (Available online at: <https://ams.confex.com/ams/97Annual/webprogram/Paper311227.html>)

Lee, D.-B., H.-Y. Chun, and J. H. Kim, 2017: Evaluation of the Global Korean Aviation Turbulence Guidance System (G-KTG) Using the Korea Meteorological Administration (KMA)'s Global Unified Model (UM). 18th Conference on Aviation, Range, and Aerospace Meteorology (ARAM), Seattle, WA, Amer. Meteor. Soc., 4.1A. (Available online at: <https://ams.confex.com/ams/97Annual/webprogram/Paper309177.html>)

Lynam, L., B. P. Pettegrew, B. Entwistle, and S. Silberberg, 2017: Establishing an Operational Baseline for Severe Clear Air Turbulence Indices. 18th Conference on Aviation, Range, and Aerospace Meteorology, Seattle WA, Amer. Meteor. Soc., 708. (Available online at: <https://ams.confex.com/ams/97Annual/webprogram/Paper300981.html>)

Mamrosch, R., B. P. Pettegrew, C. Marshall, and E. S. Brusky, 2017: An Introduction to Aircraft Weather Data for Private Sector Meteorologists. 21st Conference on Integrated Observing and Assimilation Systems for the Atmosphere, Oceans, and Land Surface, Seattle WA, Amer. Meteor. Soc., 1237. (Available online at: <https://ams.confex.com/ams/97Annual/webprogram/Paper311372.html>)

Park, S., J. Kim, R. D. Sharman, and J. B. Klemp 2016: Update of Upper-Level Turbulence Forecast by Reducing Unphysical Components of Topography in the Numerical Weather Prediction Model. Geophys. Res. Lett., 43, 14, 7718-7724. doi:10.1002/2016GL069446.

Pettegrew, B.P., 2017: Using Derived Variables from Total Lightning to Support Aviation. 8th Conference on the Meteorological Application of Lightning Data, Seattle WA, Amer. Meteor. Soc., 855. (Available online at: <https://ams.confex.com/ams/97Annual/webprogram/Paper308400.html>)

Sharman, R. D., and J.H. Kim, 2017: Global Aviation Turbulence Forecasting Techniques and Verification. 18th Conference on Aviation, Range, and Aerospace Meteorology (ARAM), Seattle, WA, Amer. Meteor. Soc., 4.5. (Recorded Presentation available at: <https://ams.confex.com/ams/97Annual/webprogram/Paper312685.html>)

PROJECT TITLE: SSMI and SSMIS Fundamental Climate Data Record Sustainment and Maintenance

PRINCIPAL INVESTIGATOR: Christian Kummerow

RESEARCH TEAM: Wes Berg, ATS

NOAA TECHNICAL CONTACT: Candace Hutchins, NOAA NESDIS/NCEI

NOAA RESEARCH TEAM: Hilawe Semunegus

FISCAL YEAR FUNDING: \$0

PROJECT OBJECTIVE:

The Climate Data Record Program (CDRP) leads NOAA's development and provision of authoritative satellite climate data records (CDRs) for the atmospheres, oceans and land. This project's objective is to provide NOAA with a fundamental climate Data record of Special Sensor Microwave/Imager (SSMI) and Special Sensor Microwave Imager and Sounder (SSMIS) data records. For the currently orbiting SSMIS sensors, the records are broken into Interim Climate Data Records (ICDR) produced rapidly using automated QC and trending information as well as the fundamental data record (FCDR) produced roughly six months after acquisition. In addition, gridded ICDR/FCDR files are provided over the entire data record. The objectives further relate to distribution of data, interface for the community, and including new satellite data streams when these become available.

PROJECT ACCOMPLISHMENTS:

An updated SSMI(S) Brightness Temperature Implementation Plan that describes the deliverables and major tasks for this period was delivered August 1, 2016. It specifies monitoring of ICDR products, ongoing production and delivery of daily ICDR updates to NCEI, ongoing production and delivery of gridded ICDR updates to NCEI, and the evaluation and conversion of ICDR to FCDR files. Unfortunately, in early February of 2016 communications were lost with the DMSP F19 spacecraft leading to associated the loss of the SSMIS data. In addition, changes to the positioning of the solar panels on F17 led to increased noise in the 37 GHz vertically polarized channel. An investigation into this issue originally identified through the ongoing instrument monitoring found that the return of noise in this channel to within specifications was short lived, resulting in flagging and setting the affected data to missing. In the subsequent FCDR production care was taken to properly identify and flag all of the affected data. This situation highlights the importance of regular instrument monitoring as well as the production of interim climate data record (ICDR) files, that are only converted to FCDR once they have been verified and any issues that are identified have been resolved. We currently produce and delivering daily updates (via ftp pull from NCEI) of the pixel level and gridded ICDR products for F15, F16, F17 and F18.

With the demise of SSMIS on board DMSP F19 in early February of 2016, the associated data record is less than 1 ½ years. We thus finalized the F19 corrections, converted the data to an FCDR, and delivered it to NCEI along with the FCDR updates for the other four operating instruments.

The implementation plan also details the external dependencies, and details the quality control procedure we have implemented. We also provided an updated quality assurance document in January of 2016 (and recently updated again in March of 2017) that highlights the progress made in monitoring the quality of the intercalibrated Tb, although this effort is ongoing. Part of the quality assurance involves evaluation of retrieved geophysical products as shown in the following comparison of F17 and F19 precipitation estimates. We not only monitor the operational precipitation products, but we also use a 1D variational retrieval algorithm for non-precipitating ocean scenes, to retrieve total precipitable water and vertical profile information, ocean surface wind speed, and cloud water. This retrieval is very sensitive to calibration errors and it provides another useful tool for quality assurance of the SSMI(S) FCDR dataset.

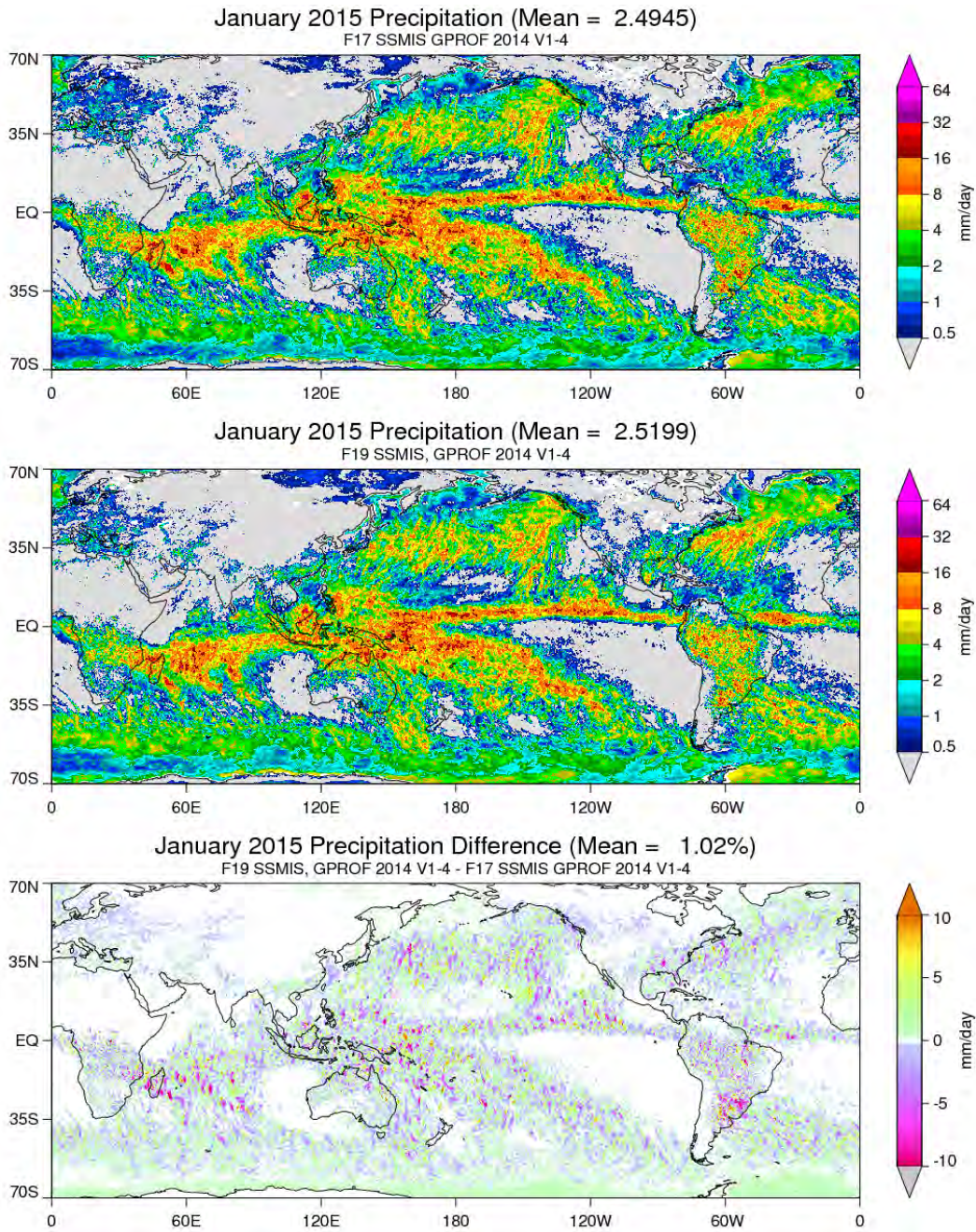

January 2015 monthly mean precipitation from the operational GPM retrieval algorithm for the SSMIS sensors on board a) F17, b) F19, and c) F19 – F17. Preliminary corrections have been developed and applied for cross-track biases, geolocation/pointing errors, and intercalibration adjustments over both cold and warm scenes. The comparison with F17 is shown as the local ascending equatorial crossing time is very similar, but not identical, between these two sensors. As a result, some residual differences due to diurnal cycle effects are expected, particularly over land.

PROJECT TITLE: Weather Satellite Data and Analysis Equipment and Support for Research Activities

Principal Investigators: Chris Kummerow / Michael Hiatt

Research Team: Michael Hiatt

NOAA TECHNICAL CONTACT: N/A

NOAA RESEARCH TEAM: None

FISCAL YEAR FUNDING: \$75,000

PROJECT OBJECTIVES:

- 1--Earthstation: Operations and maintenance for 4 antennas and associated telemetry, network, ingest, processing, distribution, and archive
- 2--Data Collection: All direct readout GOES GVAR via 3 GOES systems, GOES special collections, MSG via 7M DOMSAT system, and 22 project products via Internet
- 3--Data Distribution and Archive: Blu-ray media, archive writers, and online RAID storage
- 4--Personnel Salary: Part time coverage for one Electrical Engineer

PROJECT ACCOMPLISHMENTS:

- 1--All data sets collected, processed, cataloged, distributed, and archived at 99.9% level. Online archive now spans from 1987-2017 with approximately 600TB online data and Blu-ray backups.
- 2--2 large RAID NAS units added for additional storage
- 3--2 processing server upgraded
- 4--Telemetry maintenance

Publications: N/A

MAJOR PUBLICATIONS/PRESENTATIONS MATRIX

	2012	2013	2014	2015	2016
CI Lead Author	31 Peer Reviewed 114 Non-peer Reviewed	23 Peer Reviewed 98 Non-peer Reviewed	28 Peer Reviewed 13 Non-peer Reviewed	30 Peer Reviewed 5 Non-peer Reviewed	57 Peer Reviewed 19 Non-peer Reviewed
NOAA Lead Author	25 Peer Reviewed 69 Non-peer Reviewed	28 Peer Reviewed 40 Non-peer Reviewed	21 Peer Reviewed 17 Non-peer Reviewed	35 Peer Reviewed 0 Non-peer Reviewed	43 Peer Reviewed 20 Non-peer Reviewed
Other Lead Author	30 Peer Reviewed 43 Non-peer Reviewed	31 Peer Reviewed 33 Non-peer Reviewed	51 Peer Reviewed 5 Non-peer Reviewed	34 Peer Reviewed 6 Non-Peer Reviewed	41 Peer Reviewed 17 Non-peer Reviewed

CIRA EMPLOYEE MATRIX

CIRA Personnel					
Category	Number	None	B.S.	M.S.	PhD.
Research Scientist	23	0	0	0	23
Visiting Scientist	0	0	0	0	0
Postdoctoral Fellow	5	0	0	0	5
Research Support Staff	69	3	23	34	9
Administrative	5	0	3	2	0
Total (\geq 50% support)	102	3	26	36	37
Undergraduate Students	7	3	2	2	0
Graduate Students	16	0	5	8	3
Employees that receive < 50% NOAA Funding (not including students)	84	7	17	28	32
		ESRL	MDL	AWC	NESDIS
Located at Lab (name of lab)	90	50	10	13	17
Obtained NOAA employment within the last year	1				

Other Agency Awards 2016/17
(Sorted by Awarding Agency)

	Title	Lead NOAA Collaborator	Awarding Agency	Fiscal Year Funding
Jones	Near Real-time Improvements of the CSU Regional Multi-satellite Precipitation Product	No	aWhere	\$0
Connell	CIRA Support to Building Regional Climate Capacity in the Caribbean	No	Caribbean Institute for Meteorology & Hydrology	\$0
Chandra V.	Overseas Training Program with CUIT	No	Chengdu University of Information Technology	\$158,125
Liston	Changes in Climate and Its Effect on Timing of Snowmelt and Intensity Duration Frequency Curves	No	Department of Defense	\$129,617
Miller	Advanced Algorithm Development for Next-Generation Satellite Systems	No	Department of Defense NRL	\$0
Miller (Zupanski)	Advancing Littoral Zone Aerosol Prediction via Holistic Studies in Regime-dependent Flows	No	Department of Defense	\$89,520
Miller	CIRA Data Processing Center Support for the CloudSat Mission	No	JPL	\$968,662
O'Dell	OCO-3	No	JPL	\$80,000
Schumacher, A.	Joint Typhoon Warning Center	No	JTWC	\$315,000
Kummerow	On the Implementation and Application of Cloud Analysis and Nowcasting (CAN) System to Support the International Collaborative Experiments for Pyeongchang 2018 Winter Olympic and Paralympic Games	No	KMA	\$100,000
Baker	A Global High-resolution Atmospheric Data Assimilation System for Carbon Flux Monitoring and Verification	No	NASA	\$71,807
Baker	GEOS-Carb II: Delivering Carbon Flux and Concentration Products Based on the GEOS Modeling System	No	NASA	\$0

Other Agency Awards 2016/17
(Sorted by Awarding Agency)

	Title	Lead NOAA Collaborator	Awarding Agency	Fiscal Year Funding
Liston	Snow on Sea Ice: Data Fusion Using Remote Sensing and Modeling	No	NASA	\$0
O'Dell	A Data Record of the Cloudy Boundary Layer	No	NASA	\$86,042
O'Dell	Atmospheric Carbon Transport America (ACT-America)	No	NASA	\$84,782
O'Dell	Enhancing OCO-2's Observational Capabilities Under Partly and Fully Cloudy Con	No	NASA	\$32,329
O'Dell	Orbiting Carbon Observatory (OCO-2) Task	No	NASA	\$421,905
O'Dell	Tackling Aerosol and CO2 Uncertainties through the Synergistic Use of MODIS and OCO-2 Observations	No	NASA	\$215,813
Schranz	Using Earth Observations to Assess the Socioeconomic Impact of Human Decision Making During the Suppression of a Wildland Fire	No	NASA	\$105,275
Schranz	Wildland Fire Behavior and Risk Forecasting	No	NASA	\$154,039
Schuh	Improved Parameterization of Carbon Cycle Models Across Scales Using OCO-2 Measurements of XCO2	No	NASA	\$0
Zupanski	Advancing Coupled Land-atmosphere Modeling with the NASA-unified WRF via Process Studies and Satellite-scale Data Assimilation	No	NASA	\$23,368
Baker	GOES-CARB: A Framework for Monitoring Carbon Concentrations and Fluxes	No	NASA (via Pawson)	\$0
Liston	Norwegian Young Sea Ice Cruise	No	NPI	\$0
Hand	Assistance for Visibility Data Analysis and Image Display Techniques	No	NPS	\$947,551
McClure	Data Warehouse for Air Quality Modeling in the Oil and Gas Regions of Wyoming, Utah, and Colorado	No	NPS	\$177,145

Other Agency Awards 2016/17
(Sorted by Awarding Agency)

	Title	Lead NOAA Collaborator	Awarding Agency	Fiscal Year Funding
McClure	Intermountain West Data Warehouse for Air Quality Modeling in the Oil and Gas Regions of Wyoming, Utah and Colorado	No	NPS	\$0
Chirokova	Conversion of CIRA's AMSU-based Wind Retrieval Algorithm into a Real-time Pre-operational NRL SSMIS Application	No	NRL	\$145,000
Fletcher/ Jones	Analyzing the Impacts of Non-Gaussian Errors in Gaussian Data Assimilation Systems	No	NSF	\$0
Liston	Collaborative Research: Nutritional Landscapes of Arctic Caribou	No	NSF	\$251,924
Liston	Collaborative Research: Snow, Wind and Time: Understanding Snow Redistribution and Its Effects on Sea Ice Mass Balance	No	NSF	\$212,551
Liston, Hiemstra	Collaborative Research: AON A Snow Observing Network to Detect Arctic Climate Change-Snow Net II	No	NSF	\$0
Lu	Collaborative Research: Sensitivity of Regional Climate Due to Land-cover Changes in the Eastern U.S. Since 1650	No	NSF	\$0
Lu	Investigating Feedbacks Between Vegetation, Aerosol and Cloud Processes Using Observations and a Unified Regional Climate Model	No	NSF	\$0
Fletcher	Regional, Seasonal and Large Dynamical Scale Based Covariance and Humidity Control Variable Transform Implementation into NAVDAS-AR	No	ONR	\$28,000
Miller	Advancing Littoral Zone Aerosol Prediction via Holistic Studies in Regime-dependent Flows	No	ONR/MURI	\$439,447
Baker	Atmospheric Carbon and Transport Study – America (ACT – America)	No	Penn State Univ (NASA Prime)	\$109,978

Other Agency Awards 2016/17
(Sorted by Awarding Agency)

	Title	Lead NOAA Collaborator	Awarding Agency	Fiscal Year Funding
Schuh, Ogle	Quantification of the Regional Impact of Terrestrial Processes on the Carbon Cycle Using Atmospheric Inversions	No	Penn State (NASA)	\$78,539
Kummerow	Subaward for Advancing Water Supply Forecasts in the Colorado River Basin for Improved Decision Making	No	Riverside Technology (NASA)	\$58,382
Chandra	Radar Deployment to Santa Clara Valley Water District for Flood Monitoring	No	SCVWD	\$0
Johnson/ Labadie	Improve Precipitation and River Flow Forecasting to Maximize Water Capture for Fisheries		Sonoma County Water District	\$0
Liston	Blending Fine-scale Terrestrial Snow Information with Coarse-scale Remote Sensing Data Using Inferential and Modeling Methods	No	UAF	\$112,341
Hand	Assistance for Creation of Interactive Tools and Other Outreach Products to Enhance the Public Understanding of Air Quality Degradation on Natural Resources in US Fish and Wildlife Refuges		USFWS	\$170,214
McClure	Intermountain West Data Warehouse Development and Operations Support	No	WESTAR	\$0
Connell	Tasks Related to Technical Support of the WMO-GGMS Virtual Lab for Education and Training	No	WMO	\$65,000

NOAA PROJECTS BY TITLE

	Page
A Cooperative Institute to Investigate Satellite Applications for Regional/global-scale Forecasts	xxvii
A GOES-R Proving Ground for National Weather Service Forecaster Readiness And Training	22
Applications of Concurrent Super Rapid Sampling from GOES-14 SRSOR, Radar and Lightning Data	17
ATMS Precipitable Water Algorithms and Products – Blended-Hydromet Products Validation	18
Building a "Citizen Science" Soil Moisture Monitoring System Utilizing the CoCoRaHS Network	225
CIRA Collaboration with ESRL Physical Sciences Division on Hydrologic Research and Water Resources Applications Outreach Coordination	237
CIRA Research Collaborations with the NWS Meteorological Development Lab on Virtual Laboratory, Innovation Web Portal, Impacts Catalog and AWIPS II Projects	264
CIRA Support to Connecting GOES-R with Rapid-update Numerical Forecast Models for Advanced Short-term Prediction and Data Fusion Capabilities	19
CIRA Support for Development and Evaluation of JPSS-1 Based Tropical Cyclone Intensity and Structure Estimates	46
CIRA Support for Dynamical Core Selection for the Next Generation Global Prediction System (NGGPS)	49
CIRA Support for Feature-Based Validation of MIRS Soundings for Tropical Cyclone Analysis and Forecasting	50
CIRA Support to Improving CRTM Solar Reflection	52
CIRA Support to the JPSS Proving Ground and Risk Reduction Program: Addressing NWS Desires for a Cloud Cover Layers Product using Merged VIIRS and ATMS Products	56
CIRA Support to the JPSS Proving Ground and Risk Reduction Program: Application of Joint Polar Satellite System (JPSS) Imagers and Sounders to Tropical Cyclone Track and Intensity Forecasting	59
CIRA Support to the JPSS Proving Ground and Risk Reduction Program: Cold Air Aloft Aviation Hazard: Detection Using Observations from the JPSS Satellites and Applications to the Visualization of Gridded Soundings in AWIPS II	71
CIRA Support to the JPSS Proving Ground and Risk Reduction Program: Improving NUCAPS Soundings for CONUS Severe Weather Applications via Data Fusion	80
CIRA Support to the JPSS Proving Ground and Risk Reduction Program: In Pursuit of the Shadows: VIIRS Day/Night Band Research Enabling Scientific Advances and Expanded Operational Awareness of the Nocturnal Environment	74

CIRA Support to the JPSS Proving Ground and Risk Reduction Program: Integration of JPSS Experiment Products in AWIPS II through EPDT Code Sprints	271
CIRA Support to the JPSS Proving Ground and Risk Reduction Program: JPSS Satellite Training for NOAA Users	85
CIRA Support to the JPSS Science Program: S-NPP VIIRS EDR Imagery Algorithm and Validation Activities and S-NPP VIIRS Cloud Validation	91
CIRA Support of NOAA's commitment to the Coordination Group for Meteorological Satellites: Enhancing the International Virtual Laboratory	99
CIRA Support for the Organization of the 2016 Group for High Resolution Sea Surface Temperature (GHR SST) XVII Meeting	104
CIRA Support to RAMMB Infrastructure for GOES-R Rebroadcast Data Collection at CIRA/CSU – EOY StAR Project	106
CIRA Support for Research and Development for GOES-R Risk Reduction for Mesoscale Weather Analysis and Forecasting and Training	107
CIRA Support for Tropical Cyclone Model Diagnostics and Product Development Hurricane Forecast Improvement Project	122
CIRA Support of the Virtual Institute for Satellite Integration Training (VISIT)	126
CSU/CIRA Support for ATMS SI Traceable Calibration Effort	130
Enhancing NIDIS Drought Monitoring and Early Warning in the Upper Colorado River Basin	242
<u>Environmental Applications Research (EAR)</u>	
<i>Addressing Model Uncertainty through Stochastic Parameter Perturbation with the HRRR Ensemble (DTC-Task)</i>	200
<i>Aviation Weather Forecast Impact and Quality Assessment</i>	275
<i>AWIPS I and AWIPS II Workstation Development</i>	282
<i>Citizen Weather Observer Program</i>	292
<i>Data Assimilation for the High Resolution Rapid Refresh (HRRR) System</i>	213
<i>Evaluation of Chemical Data Assimilation Systems for PM2.5 Observations Using WRF-Chem and CMAQ</i>	212
<i>Flow-following Finite-volume Icosahedral Model (FIM) Development Project</i>	192
<i>Flow-following Finite-volume Icosahedral Model (FIM) Data Distribution</i>	273
<i>HRRR-based Ensemble Repository Maintenance and Rocoto End-to-end Workflow (DTC Task)</i>	197
<i>High Performance Computing</i>	193
<i>Implementation and Testing of the Grell-Freitas Convective Parameterization in the NOAA Environmental Modeling System-based Global Spectral Model (GMTB-Task)</i>	206
<i>Improving Short-range Forecasts of Severe Weather and Aviation Weather from Enhancements To the Assimilation of Satellite Infrared Radiance Data from SEVIRI and GOES-R ABI</i>	207
<i>Local Analysis and Prediction System (LAPS)</i>	213
<i>Model Evaluation</i>	209
<i>Meteorological Assimilation Data Ingest System (MADIS)</i>	290
<i>Nonhydrostatic Icosahedral Model (NIM) Project</i>	193
<i>RAP and HRRR 4DVar Testing and Evaluation</i>	203
<i>Rapid Update Cycle Rapid Refresh (RAP) and High-resolution Rapid Refresh (HRRR) Assimilation Development and Enhancement</i>	196
<i>Rapid Update Cycle (RUC) Rapid Refresh (RAP) and High-resolution Rapid Refresh</i>	

<i>(HRRR) Models Project, Data Distribution and Visualization</i>	279
<i>Refinement and Evaluation of Automated High-resolution Ensemble-based Hazard Detection Guidance Tools for Transition to NWS Operations (GSD-Task)</i>	198
<i>Research Collaboration with Information and Technology Services</i>	293
<i>Science on a Sphere (SOS®) Development</i>	295
<i>TerraViz (also branded as SOS Explorer)</i>	299
Expanding Precipitation Measurements in the Commonwealth of the Bahamas through the CoCoRaHS (Community Collaborative Rain, Hail and Snow) Network	249
Explicit Forecasts of Recurrence Intervals for Rainfall: Evaluation and Implementation Using Convection-allowing Models	260
Hydrometeorological and Water Resources Research	219
Instructional Development and Learning Support for NOAA's OMAO's Chief Learning Officer (CLO), OMAO Kansas City Missouri	303
NESDIS Environmental Applications Team (NEAT)	
<i>I-Wen Chu, Research Scientist</i>	137
<i>Yanni Ding, Post Doc</i>	138
<i>Suryakanti Dutta, Research Associate</i>	141
<i>Lide Jiang, Research Scientist</i>	148
<i>Shuyan Liu, Research Scientist</i>	151
<i>Xiaoming Liu, Research Scientist</i>	152
<i>Zhiyong Liu, Post Doc</i>	156
<i>Wei Shi, Research Scientist</i>	160
<i>SeungHyun Son, Research Scientist</i>	165
<i>Liqin Tan, Research Associate</i>	171
<i>Sirish Uprety, Research Associate</i>	173
<i>XiaoLong Wang, Research Associate</i>	176
<i>Xin Xi, Post Doc</i>	178
<i>Xinjia Zhou, Research Associate</i>	181
<i>Tong Zhu, Research Scientist</i>	184
POES-GOES Blended Hydrometeorological Products	187
Research Collaboration at the NWS Aviation Weather Center in Support of the Aviation Weather Testbed, Aviation Weather Research Program, and the NextGen Weather Program	307
SSM/I and SSMIS Fundamental Climate Data Record Sustainment and Maintenance	327
Using JPSS Retrievals to Implement a Multisensor Synoptic Layered Water Vapor Product for Forecasters	189
Weather Satellite Data and Analysis Equipment and Support for Research Activities	329

COMPETITIVE PROJECTS

- 1—Accounting for Non-Gaussianity in the Background Error Distributions Associated with Cloud-related Variables (microwave radiances and hydrometeors) in Hybrid Data Assimilation for Convective-scale Prediction (NA16OAR4590233) (Fiscal Year Funding: \$304,677)
- 2--Assessment of Gridded Hydrological Modeling for NWS Flash Flood Operations (NA15OAR4590152) (Fiscal Year Funding: \$78,522)
- 3—Assimilation of Lake and Reservoir Levels into the WRF-Hydro National Water Model to Improve Operational Hydrologic Predictions (NA16OAR4590237) (Fiscal Year Funding: \$50,000)
- 4--Collaborative Research: Assessing Oceanic Predictability Sources for MJO Propagation (NA16OAR4310094) (Fiscal Year Funding: \$127,825)
- 5--Development of a Framework for Process-oriented Diagnosis of Global Models (NA15OAR4310099) (Fiscal Year Funding: \$81,903)
- 6—Following Emissions from Non-traditional Oil and Gas Development through Their Impact on Tropospheric Ozone (NA14OAR4310148) (Fiscal Year Funding: \$0)
- 7—Forecasting North Pacific Blocking and Atmospheric River Probabilities: Sensitivity to Model Physics and the MJO (NA16OAR4310064) (Fiscal Year Funding: \$208,010)
- 8—Implementation and Testing of Lognormal Humidity and Cloud-related Control Variables for the NCEP GSI Hybrid EnVar Assimilation Scheme (NA16NWS4680012) (Fiscal Year Funding: \$199,891)
- 9—Improvement and Implementation of the Probability-based Microwave Ring Rapid Intensification Index for NHC/JTWC Forecast Basins (NA15OAR4590200) (Fiscal Year Funding: \$9,432)
- 10--Improvement to the Tropical Cyclone Genesis Index (TCGI) (NA15OAR4590202) (Fiscal Year Funding: \$42,587)
- 11—Improvements to Operational Statistical Tropical Cyclone Intensity Forecast Models (NA15OAR4590204) (Fiscal Year Funding: \$85,362)
- 12—Improving CarbonTracker Flux Estimates for North America Using Carbonyl Sulfide (OCS) (NA13OAR4310080) (Fiscal Year Funding: \$0)
- 13—Improving Probabilistic Forecasts of Extreme Rainfall through Intelligent Processing of High-resolution Ensemble Predictions (NA16OAR4590238) (Fiscal Year Funding: \$223,420)
- 14—Improving Understanding and Prediction of Concurrent Tornadoes and Flash floods with Numerical Models and VORTEX-SE Observations (NA16OAR4590215) (Fiscal Year Funding: \$180,977)
- 15--Investigating the Underlying Mechanisms and Predictability of the MJO – NAM Linkage During Boreal Winter in the NMME Phase-2 Model Suite (NA16OAR4310090) (Fiscal Year Funding: \$21,173)
- 16—Multi-disciplinary Investigation of Concurrent Tornadoes and Flash Floods in the Southeastern US (NA15OAR4590233) (Fiscal Year Funding: \$0)
- 17--Observational Constraints on the Mechanisms that Control Size- and Chemistry-resolved Aerosol Fluxes Over a Colorado Forest (NA14OAR4310141) (Fiscal Year Funding: \$0)
- 18--Quantifying Stochastic Forcing at Convective Scales (NA16OAR4590230) (Fiscal Year Funding: \$366,470)

19--Research to Advance Climate and Earth System Models Collaborative Research: A CPT for Improving Turbulence and Cloud Processes in the NCEP Global Models (NA13OAR4310103) (Fiscal Year Funding: \$70,000)

20--Towards Assimilation of Satellite, Aircraft, and Other Upper-Air CO2 Data into CarbonTracker (NA13OAR4310077) (Fiscal Year Funding: \$0)

21--Upgrades to the Operational Monte Carlo Wind Speed Probability Program (Fiscal Year Funding: \$0)

22--Use of the Ocean-Land-Atmosphere Model (OLAM) with Cloud System-Resolving Refined Local Mesh to Study MJO Initiation (NA13OAR4310163) (Fiscal Year Funding: \$0)

PROJECT TITLE: Accounting for Non-Gaussianity in the Background Error Distributions Associated with Cloud-related Variables (microwave-radiances and hydrometeors) in Hybrid Data Assimilation for Convective-scale Prediction

PRINCIPAL INVESTIGATORS: Karina Apodaca (CSU/CIRA at NOAA/ESRL/GSD/GOSA) and Steven J. Fletcher (CSU/CIRA)

RESEARCH TEAM: N/A

NOAA TECHNICAL CONTACT: N/A

NOAA RESEARCH TEAM: Stephen Weygandt NOAA/ESRL/GSD/ADB and Haidao Lin CSU/CIRA at NOAA/ESRL/GSD/ADB

PROJECT OBJECTIVES:

The overarching project objective is to further develop to the hybrid Gridpoint Statistical Interpolation (GSI) data assimilation system via the incorporation of a mixed-distribution approach for a better representation of background error statistics of variables associated with clouds to enhance the NWS capability to forecast high-impact weather that occurs at convective scales. Specifically, the project contributes to these goals by:

- 1--Developing the infrastructure for non-Gaussian statistics in the background error (BE) components (cost function and background error covariance matrix) of the hybrid GSI system
- 2--Implementing a tool for an improved first-guess of cloud-related fields
- 3--Developing the methodology and guidelines for implementing and applying the mixed-distribution for the BE in data assimilation cycling experiments

PROJECT ACCOMPLISHMENTS:

The following is a list of project-specific milestones, along with dates, as stated in the original proposal:

FY 2016-2017: Algorithm development and preliminary testing:

Year 1:

- 1) December 2016 - Coordinate with the NOAA/ESRL/GSD collaborators to obtain computer accounts on the Jet and/or Theia supercomputers.
- 2) January 2017 - Identify extreme-precipitation events (e.g. associated w/ TC remnants)
- 3) February 2017 - Conduct retrospective data assimilation experiments with benchmark versions

The following tasks have been done in association with the above-mentioned milestones.

--Obtained a branch (operational copy) of the hybrid GSI from NCEP/EMC and installed it on the Theia supercomputer.

--Met with the ESRL/GSDADB to learn how to run the RAP/HRRR system

--Met with some members of the Data Assimilation group at NCEP/EMC to lay out the strategy to coordinate all development efforts in the hybrid GSI system to ensure a smooth transition to operation.

--Developed a research to operations transition plan in coordination with the Office of Atmospheric Research-appointed NWS POC for this project *i.e.* Emily Liu from the Data Assimilation group at NCEP/EMC and with additional contributions from John Derber, Division Chief from EMC

--A collaborative visit to NCEP/EMC is scheduled for the week of April, 2017

We began to finalize the methodology and guidelines for implementing and applying the mixed-distribution for the BE in data assimilation cycling experiments. We have now started our initial development of the hybrid GSI system, which focuses on the inner-loop minimization of the variational solver of the hybrid GSI data assimilation system. Figure 1, shows a flow diagram of the hybrid GSI system, including new developments.

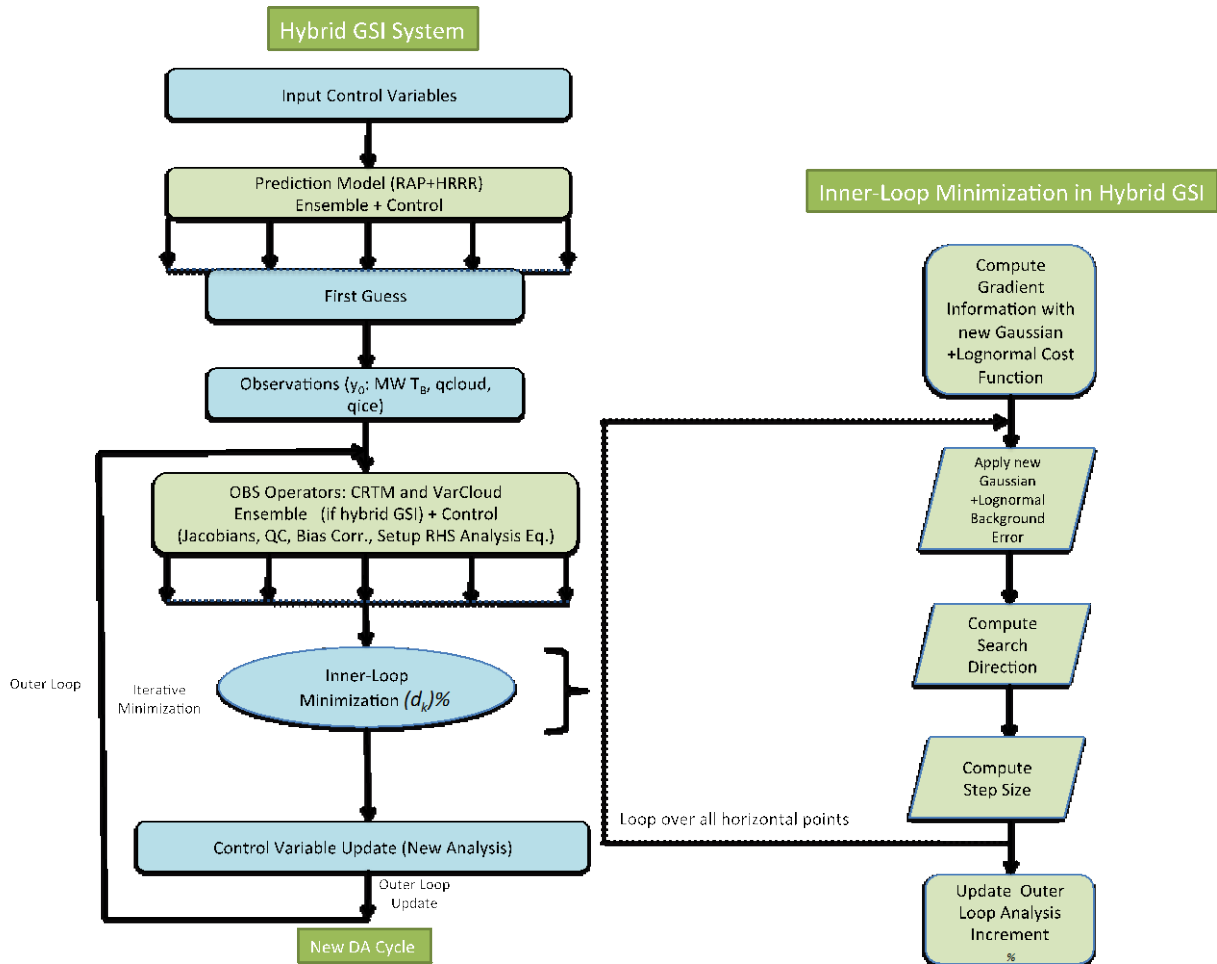

Figure 1. Flow diagram of the hybrid GSI system including new developments related to the mixed-distribution for the background errors

Preliminary retrospective experiments with the experimental version of the GSI and RAP/HRRR system GSI and RAP/HRRR and the benchmark (operational) version of the same system have been conducted for the May, 2015 Houston area floods. We have begun to notice differences between the (Fig. 2) experimental (left) and benchmark (middle) versions, with the experimental showing a wide spread area of high precipitation contours on the experimental version, as compared observed amounts (right).

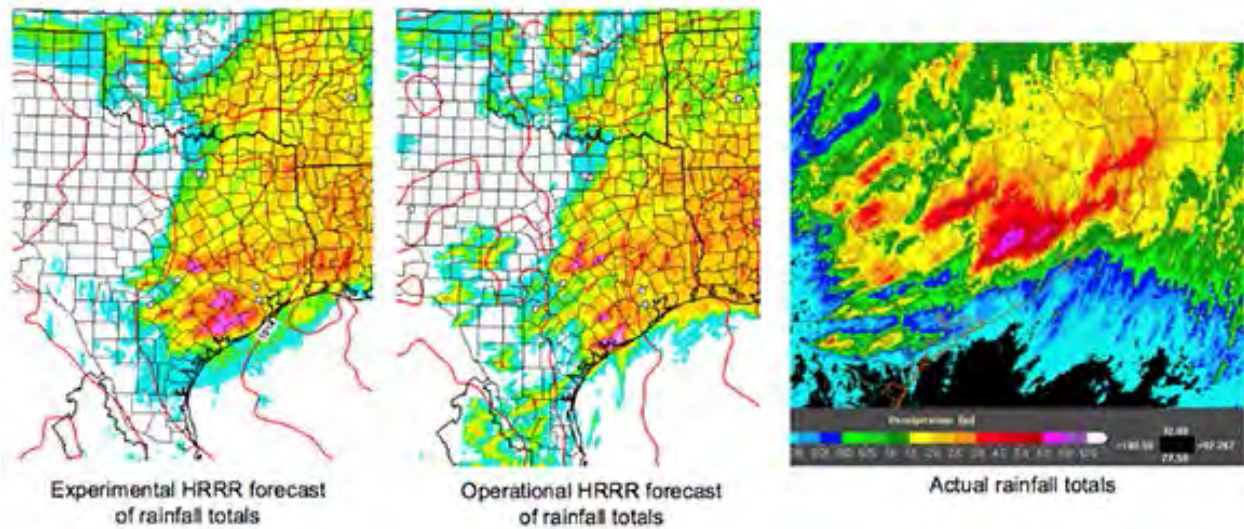

Figure 2. Total surface precipitation amounts: (left) experimental system, (middle) benchmark system, and (right) observed precipitation amounts. Courtesy: Eric James – NOAA/ESRL/GSD/ADB

Publications:

Apodaca, K. and Fletcher S. J.: Implementation of Cloud-Related Non-Gaussian Background Error Statistics in Hybrid Data Assimilation for Convective Scale Prediction. *Advances in Methodologies 1*. 21st Conference on Integrated Observing and Assimilation Systems for the Atmosphere, Oceans, and Land Surface. 97th Annual AMS Meeting, Seattle, Washington. January 22-27, 2017.

Fletcher, S.J. and Apodaca K.: Accounting for Non-Gaussianity in Background Errors Associated with Cloud-Related Variables. 21st Conference on Integrated Observing and Assimilation Systems for the Atmosphere, Oceans, and Land Surface. 97th Annual AMS Meeting, Seattle, Washington. January 22-27, 2017.

Federal Agency and Organization Element to Which the Report is Submitted

NOAA Office of Oceanic and Atmospheric Research (OAR) Office of Weather and Air Quality (OWAQ)
FY2015 US Weather Research Program
Hydrometeorology Testbed (HMT) and Hazardous Weather Testbed (HWT)

Federal Grant Number Assigned by Agency

GRANT AWARD # NA15OAR4590151

Project Title

Assessment of Gridded Hydrological Modeling for NWS Flash Flood Operations

Project Director/Principal Investigator (PD/PI) Name, Title and Contact Information (e-mail address and phone number)

(Co-PIs)

Lynn E. Johnson, Senior Research Hydrologist
Email: Lynn.E.Johnson@noaa.gov; Phone: 303-775-5544

James Halgren, Water Resources Engineer
Ft. Collins, CO 80525
Email: James.Halgren@riverside.com; Phone: 970-498-1837

Submission Date

September 28, 2016

Recipient Organization (Name and Address)

Cooperative Institute for Research in the Atmosphere
Colorado State University, Fort Collins, CO 80523-1375

Riverside Technology, inc.
2950 E Harmony Road, Suite 390, Fort Collins, CO 80528

Project/Grant Period (Start Date, End Date)

September 1, 2015 to August 31, 2017

Reporting Period End Date

August 31, 2016

Report Term or Frequency (annual, semi-annual, quarterly, other)

Annual Progress Report

Final Annual Report? Select Yes or No

No

1. ACCOMPLISHMENTS

What were the major proposed goals, objectives, and tasks of this project, and what was accomplished this period under each task? (a table of planned vs. actuals is recommended as a function of each task identified in the funded proposal)

Objectives of Study

The overall goal of this research-to-operations activity is to assess whether a distributed hydrologic modeling approach can provide enhanced hydrologic services for flash flood and other water resources purposes by the NWS and its partner water management agencies. Objectives of this research-to-operations activity include:

- Prototype and demonstrate the ability to provide flash flood information at scales and at locations not currently served by RFC operations;
- Implement the RDHM as a prototype R2O demonstration. Build off the existing RDHM database and model of the Russian River as an initial prototype, and then extend to the entire WFO-MTR (Monterrey);
- Interface the RDHM to WFO precipitation forcing datasets available in real-time at the WFO and HMT. Display RDHM outputs using hydrologic modeling software such as CHPS/FEWS and web services. Utilize these precipitation data feeds to assess potential improvements in runoff predictions with the distributed modeling approach.
- Inform the ongoing effort within the NWC to develop a concept of operations, requirements specification, and toolkit for DHM implementation and application for NWS flash flood operations;
- Coordinate with the NWS agencies involved with hydrologic operations in assessment of the RDHM for WFO operations, including the WFO-MTR, CNRFC, NWC and Western Region (WR). Include extended forecast support for ecological purposes, such as for the National Marine Fisheries Service (NMFS) in the Russian River basin.
- Assess the RDHM implementation to determine how best to implement the model to support flash flood operations, identify constraints and opportunities for enhanced flood and water management applications which could be sustained by WFO/RFC RDHM operations.

Project Tasks

Five tasks were formulated to carry the project forward.

Task 1: Coordination

Coordinate with the NWS agencies involved with hydrologic operations in assessment of the Distributed Hydrological Model (DHM) for WFO operations, including the WFO-MTR, CNRFC, OHD and WR. For this project we have convened an Advisory Panel (AP) to help provide guidance and counsel on the two primary aspects of this project, namely: a) technical aspects of DHM data handling, computing and decision support visualizations; and b) administrative aspects of the concept of operations (Conops) for how DHM functionality could be implemented and the division of responsibility for forecast operations.

Task 2: Assessment

Conduct descriptive and reflective assessments of the DHM approach with participating NWS forecasters and other users. Methods for assessment were described by Johnson et al (1998) and include so-called descriptive and reflective approaches.

Task 3: Prototype

Maintain and advance the DHM/CHPS/FEWS implementation at ESRL to support a prototype R2O demonstration. The DHM/CHPS/FEWS implementation at ESRL will be extended to support the R2O

demonstration and assessment of other project activities. The initial phases will build directly from the existing DHM database and model of the Russian-Napa Rivers. A Hydrometeorological Visualization Tool (HVT) is developed using a Google Maps interface so that it can be widely deployed and accessed using a commonly available interface familiar to most users. The HVT has been coupled to the CHPS-FEWS using export-import functions. Google Map layers emphasizing flash flood impact features have been developed.

Task 4: Interface

Interface the DHM to WFO precipitation forcing datasets available in (near) real-time at the WFO and HMT; archive significant event data for retrospective study. The Russian River RDHM implementation at ESRL currently uses CNRFC QPE data for the observed period to establish model state, HRRR data for the short term forecast period, and NDFD forecasts for extended precipitation. Additional observed period grids are developed locally by the WFO precipitation as MPE data and nationally by NSSL as an MRMS product, both of which are available in (near) real-time at the WFO and HMT.

Task 5: Evaluate

Established foundation for eventual evaluation through communications with the Advisory Panel, establishing DHM in CHPS/FEWS, and advancing work plan for assessment forums and tools. Evaluate the DHM implementation to determine how best to implement the model to support WFO and RFC hydrologic operations. Identify constraints and opportunities for enhanced services, and flood and water management applications, which could be sustained by WFO/RFC DHM operations.

PROJECT ACCOMPLISHMENTS: (Research Conducted) Past Fiscal Year by Objective:

Progress on the various tasks is summarized in the following Table 1. More detailed descriptions of project activities and out comes is provided in the follow report narrative sections.

Table 1 Summary of Project Progress by Task	
<ul style="list-style-type: none"> • Task 1: Coordination <ul style="list-style-type: none"> ○ Description of Work Performed: <ul style="list-style-type: none"> ▪ Organized an advisory panel (AP) with the following members <ul style="list-style-type: none"> • Rob Hartman (NWS CNRFC) - robert.hartman@noaa.gov • Mark Strudley (NWS WFO-MTR) - mark.strudley@noaa.gov • Rob Cifelli (ESRL/PSD) - rob.cifelli@noaa.gov • Chad Kahler (NWS Western Region) - chad.kahler@noaa.gov • Mike Smith (NWS NWC) - Michael.Smith@noaa.gov • Ed Clark (NWS NWC) – edward.clark@noaa.gov (unable to attend kickoff) • Mike Anderson (CaDWR) - Michael.L.Anderson@water.ca.gov (unable to attend kickoff) • Chris Delaney (SCWA) - Chris.Delaney@scwa.ca.gov (unable to attend kickoff) • Josh Fuller (NMFS) - joshua.fuller@noaa.gov • Nezette Rydell (NWS-DEN) – nezette.rydell@noaa.gov • Jay Day (Riverside) - Jay.Day@riverside.com • Dave Reynolds (ESRL) - david.reynolds@noaa.gov ▪ The AP participants were provided with a series of one page descriptions of key aspects of the project including: the Hydro-meteorological Viewing Tool (HVT); the CHPS-FEWS implementation of the Russian River RDHM Model; assessment approach; and an overall project summary. After conferring with the AP members, a kickoff meeting was held on 12 February 2016 to describe the prototype distributed modeling application, the prototype HVT interface, and to propose the assessment 	

concept. A formal webinar was conducted with the AP on 12 April 2016 to review project progress and to demonstrate the prototype DHM modeling and visualization system. Various e-mail and telecom communications were held with AP members.

- Problems or Delays and Recommended Solutions: None
- Work Planned for Next Reporting Period: Incorporate feedback and comments from the kickoff meeting; Prepare and provide detailed assessment plan to Advisory Panel participants; Invite AP to suggest specific individuals to receive assessment material. A webinar meeting is planned for some time in November 2016 to update the AP on project progress, and to prepare for user assessment forums during the coming winter rainy season.
- Deliverables: One page summary documents
- Task 2: Assessment
 - Description of Work Performed: Five intended user groups were identified and a user-centered approach involving identification of users, and their needs and requirements was outlined. The user groups include the 1) NWS California-Nevada River Forecast Center (CNRFC), 2) NWS Weather Forecast Office – San Francisco-Monterrey (WFO-MTR), 3) Emergency Management Agencies (EMAs), 4) General Public, and 5) National Marine Fisheries Service (NMFS).
 - Problems or Delays and Recommended Solutions: None
 - Work Planned for Next Reporting Period: Finalize the assessment plan and prepare storyboards of assessment scenarios.
 - Deliverables: In progress
- Task 3: Prototype
 - Description of Work Performed: Riverside evaluated the condition of the CHPS-FEWS instance, which was unmonitored since June 2015 and brought the model back up to a current state from the June 2015 run. Riverside also upgraded the FEWS architecture to version 2015.01 (version currently in use at RFCs). With those updates, the RDHM model now executes hourly without assimilation using the disaggregated CNRFC QPE as the observed precipitation forcing and with forecasts based on the GFS precipitation fields. Cron scripts trigger a simulation every hour using 48-hour old states and forecast out to 48 hours. Model states have been developed from simulations extending back to October 2013. The system has simulated system response during significant events in December 2014, February 2015, and December-January 2015-2016. Based on the CNRFC-QPE forced simulations, a suite of model performance statistics for the most recent event was prepared and evaluated. In order to prepare model statistics, a FEWS module was prepared to incorporate the complete length of the historic simulation time series.
 - Problems or Delays and Recommended Solutions: The HRRR datasets have presented a number of challenges as the input format has changed and as we have considered the need for retrospective forecasts (which require archived HRRR data). Some issues should be resolved by upgrading the CHPS workstation to CentOS 7, which allows for the latest netcdf libraries to be used for manipulation of the HRRR grids. Likewise, upon upgrading to the later version of FEWS, there was an incompatibility with the formatting of the CNRFC grids. This incompatibility should be fully resolved with the OS and associated library upgrades.
 - Work Planned for Next Reporting Period: Finalize QPF/QPE workflows; export additional data for use in HVT; ensure all data in place for retrospective assessment. The CHPS-FEWS has been re-initiated; is running at this time, and is setup to run for the coming winter rainy season.
 - Deliverables: Provided simulation results for December-January 2015-2016 event. Assessment of the technical accuracy of the RDHM has been accomplished and documented (see appended Technical Assessment).
- Sub-task 4: Interface
 - Description of Work Performed: The HVT is being developed using a Google Maps interface so that it can be widely deployed and accessed using a commonly available interface familiar to

most users. HVT will build on existing functionality for loading RDHM grid data into Google Maps. This functionality loads the RDHM grid data from the NetCDF format using routines written in Python scripts and Matlab to convert the data into a raster image and KML file, which is then displayed in Google Maps in continuous animation using Javascript. To facilitate eventual use as part of the retrospective assessment, capability was added to the HVT to select a historic date for viewing model results from historic forecast sequences. GIS data layers have been established on watershed terrain and stream network, land use / land cover, roadways and other culture

- Problems or Delays and Recommended Solutions: Problems resolved as described.
- Work Planned for Next Reporting Period: Develop capability to compute and display at-risk road crossings on user request. Incorporate additional data display capabilities including precipitation and point hydrographs.
- Deliverables: Updated
- Sub-task 5: Evaluate
 - Description of Work Performed: This task is intended to be addressed near the end of the project. Established foundation for eventual evaluation by establishing and communicating with Advisory Panel, establishing DHM in CHPS/FEWS, and advancing work plan for assessment forums and tools.
 - Problems or Delays and Recommended Solutions: None
 - Work Planned for Next Reporting Period: Continuing to operate the DHM in CHPS/FEWS for the remainder of winter rainy season, and through the summer-fall 2017 flow recession period.
 - Deliverables: None at this time

Are the proposed project tasks on schedule? What is the cumulative percent toward completion of each task and the due dates? (see schedule table below)

Table 2 summarizes the project schedule with indication of progress as cumulative percent toward completion.

What were the major completed milestones this period, and how do they compare to your proposed milestones? (planned vs. actuals table recommended)

The major milestones associated with each task are summarized in Tables 1 and 2. In general we are exactly on schedule.

What opportunities for training and professional development has the project provided?

There has been significant interactions with the Advisory Panel on the distributed hydrologic modeling and visualizations; this might be considered training. The upcoming winter 2016-2017 rainy season will provide additional opportunity for such interactions.

How were the results disseminated to communities of interest?

We conducted two webinars with the Advisory Panel, and the prototype Hydromet Visualization Tool has been operating in (near) real-time for the Winter 2016-2016 and Spring seasons.

Table 2 Schedule and Task Completion Assessment

Task	2015												2016												2017								% Complete (9/16)								
	1	2	3	4	5	6	7	8	9	10	11	12	1	2	3	4	5	6	7	8	9	10	11	12	1	2	3	4	5	6	7	8									
1. Coordination																																									
a. Form Advisory Panel																																									
b. Progress and review meetings with AP																																									
c. Involvement of AP in assessments																																									
d. Involvement of AP in final evaluation																																									
2. Assessment																																									
a. Advisory panel guidance																																									
b. Development of assessment tools																																									
c. Retrospective case studies																																									
d. Real-time operations																																									
e. Table Top Exercises																																									
3. Prototype																																									
a. RDHM in CHPS/FEWS																																									
b. Extend prototype																																									
c. Additional gage data																																									
d. Grid editing																																									
4. Interface																																									
a. Develop visualization tools																																									
b. Deploy to web services																																									
c. Augment GHM functionality																																									
d. Maintain GHM for real-time operations																																									
5. Evaluation																																									
a. Summarize GHM assessments																																									
b. Present results																																									
c. Finalize conclusions																																									
d. Document results																																									

= Work completed
 = Work to be conducted
 = Activity documentation (internal)
 = Report / manuscript (external)

What do you plan to do during the next reporting period to accomplish the goals and objectives?

Expected activities to accomplish project goals and objectives are summarized in Tables 1 and 2.

2. PRODUCTS

What were the major completed products or deliverables this period, and how do they compare to your proposed deliverables? (planned vs. actuals table recommended)

Tables 1 and 2 summarize completed tasks and associated products. The products are those that were originally proposed.

What has the project produced?

Publications, conference papers, and presentations:

Halgren, J., L. Johnson, T. Coleman and R. Cifelli. 2015: RDHM-CHPS Research-to-Operations Demonstration, Russian-Napa River Basins, CA. Poster for 6th NOAA Testbed and Operational Proving Ground Workshop. April 14, 2016.

We have an abstract for American Meteorological Society Annual Meeting in Seattle, WA, January 22–26, 2017. Abstract is attached.

A more comprehensive report has been drafted which includes details on the Technical and Reflective Assessments completed so far. His report is available on request.

Website(s) or other Internet site(s):

The HVT can be seen here: <http://www.esrl.noaa.gov/psd/data/obs/sitemap/Anim/rdhm.php>

Technologies or techniques: NA

Inventions, patent applications, and/or licenses: NA

Other products, such as data or databases, physical collections, ...:

The project has involved development of a number of GIS layers and KML files to support the visualization.

3. PARTICIPANTS & OTHER COLLABORATING ORGANIZATIONS

What individuals have worked on this project?

- Lynn E. Johnson, CIRA
- James Halgren, RTi
- Tim Coleman, ESRL/CIRES
- John Park, RTi
- Joy Labadie, CIRA

Has there been a change in the PD/PI(s) or senior/key personnel since the last reporting period? No

What other organizations have been involved as partners? Have other collaborators or contacts been involved?

The NOAA ESRL Physical Science Division is participating in the project and has provided the foundation computing and IT infrastructure in support of the project. Tim Coleman (ESRL/PSD) is the primary staff for the Hydromet Visualization Tool.

The main NOAA PI on the project:

Rob Cifelli, Ph.D., Lead, Hydrometeorology Modeling and Applications Team
Physical Sciences Division, NOAA Earth System Research Laboratory
R/PSD2, 325 Broadway, Boulder, CO 80305-3337
(303) 497-7369, rob.cifelli@noaa.gov

4. IMPACT

What was the impact on the development of the principal discipline(s) of the project? NA

What was the impact on other disciplines? NA

What was the impact on the development of human resources? NA

What was the impact on teaching and educational experiences?

We expect the HVT web site could prove useful for educational purposes by the NWS and other university entities.

What was the impact on physical, institutional, and information resources that form infrastructure?

We have established a so-called Hydro Server at ESRL PSD that hosts the RDHM, CHPS-FEWS and web service for the HVT.

What was the impact on technology transfer?

The CHPS-FEWS implementation was updated and advanced to operate in (near) real-time, and with archival of forcing datasets to support retrospective review by NWS flash flood operations staff at the CNRFC and WFO-MTR, and other flood operations staff at the state and county agencies. The CHPS-FEWS implementation has been made available for real-time access through remote login privileges for NWS staff and project team members. Outputs from the CHPS-FEWS instance are now integrated in real-time into the HVT for direct access by WFO and RFC staff.

The CHPS-FEWS and HVT instances are rated at the Technical Readiness Level (TRL) 6 at the project outset (see insert). With the current implementation the TRL is rated greater than 6 and closer to 7 (System prototyping demonstration in an operational environment). Achievement of a full TRL of 7 is anticipated for the next winter rainy season.

What was the impact on society beyond science and technology? NA

What percentage of the award's budget was spent in a foreign country(ies)? None

5. CHANGES/PROBLEMS

Describe the following:

Changes in approach and reasons for the change: No changes in approach made.

Actual or anticipated problems or delays and actions or plans to resolve them: No delays have occurred.

Changes that had a significant impact on expenditures: No changes impacting on expenditures.

Change of primary performance site location from that originally proposed: No change in site location.

6. SPECIAL REPORTING REQUIREMENTS

We have been asked to describe the status of the DHM and HVT prototype in terms of the Technical Readiness Level. The CHPS-FEWS and HVT instances are rated at the Technical Readiness Level (TRL) 6 at

the project outset (see insert). With the current implementation the TRL is rated greater than 6 and closer to 7 (System prototyping demonstration in an operational environment). Achievement of a full TRL of 7 is anticipated for the next winter rainy season.

7. BUDGETARY INFORMATION

Is the project on budget? Yes. There are no major budget anomalies for Year 1.

8. PROJECT OUTCOMES

What are the outcomes of the award?

Outcomes of the project are summarized in Tables 1 and 2.

Are performance measures defined in the proposal being achieved and to what extent?

Project tasks and performance measures are described in Tables 1 and 2. All tasks are on schedule with completed accomplishments are described in Tables 1 and 2, and the attached narrative report.

Abstract for AMS 2017 Annual Meeting*

Title: **Distributed Hydrological Modeling for NWS Flash Flood Operations**

Authors: Lynn E. Johnson^{1,2}, James Halgren³, Rob Cifelli¹, Tim Coleman¹, Joy Labadie², and Gi-Hyeon Park³

¹NOAA/ESRL/PSD, ²CSU/CIRA; ³Riverside Technology, inc.,
Lynn.E.Johnson@noaa.gov; James.Halgren@riverside.com

National Weather Service (NWS) forecasters at the River Forecast Centers (RFCs) and Weather Forecast Offices (WFOs) provide timely and reliable severe weather and hydrological forecast services. NWS flash flood operations may be improved through applying advances in distributed hydrological modeling (DHM). Our project extends ongoing DHM research and development efforts within the NOAA Hydrometeorological Testbed (HMT) and NWS National Water Center (NWC) to conduct a US Weather Research Program-sponsored assessment of the DHM for flash flood forecast and warning operations.

The HMT has worked with the NWC to implement the Research Distributed Hydrological Model (RDHM) to support research on the evaluation of various precipitation monitoring, data assimilation, and forecasting techniques. We applied the RDHM to the Russian-Napa Rivers (RR-N) basin to support assessment of model accuracy; that work has characterized the uncertainty of flood peak predictions and water budget. Gap-filling weather radars have been used together with the DHM to examine uncertainties of precipitation nowcasting and forecasting on the simulation of surface flows.

Most recently, the HMT-West and Riverside implemented RDHM in the CHPS-FEWS computing environment, which allows a streamlined, near-real time data ingest and simulation capability. The CHPS-FEWS instance has been configured to ingest multiple Quantitative Precipitation Estimations (QPE) and Quantitative Precipitation Forecasts (QPF) forcings, including radar-rainfall products generated by the MRMS system. The CHPS-FEWS setup supports visualizations of input datasets and DHM outputs including precipitation, surface runoff, threshold frequency level, and soil moisture grids as well as animations of these. Downstream applications use the FEWS output to identify at-risk road crossings. Remote access capabilities have been established so that interested users with the NWS and others can review and comment about the modeling environment and examine performance. The system is now ready to support an R2O assessment of the DHM approach for WFO flash flood operations.

For this presentation, we will show the prototype and illustrate flood threat information at local scales and at locations not currently served by RFC operations. We will describe case study storms and summarize feedback from forecasters. After receiving and summarizing feedback, the most highly rated products will be further developed. We will also spend time discussing the equally important intent to examine WFO flash flood operations concept-of-operations to include interactions between the WFO and RFC. This objective involves close coordination with the responsible offices. And lessons learned from this effort are expected to inform future regional assessment activities of the NWC's National Water Model.

For presentation at: AMS 97th Annual Meeting, Seattle, WA. January 22–26, 2017. 33rd Environmental Information Processing Technologies. Session: Quasi-Operational Products You Can Use Now.

* This project is based upon work supported by the U.S. Weather Research Program within NOAA/OAR Office of Weather and Air Quality under Grant No. NA15OAR4590151.

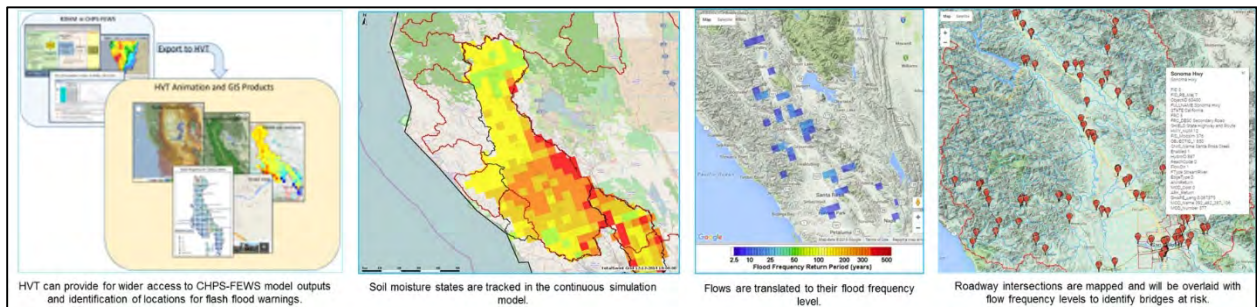

PROJECT TITLE: Assimilation of Lake and Reservoir Levels into the WRF-Hydro National Water Model to Improve Operational Hydrologic Predictions (NA16OAR4590237)

PRINCIPAL INVESTIGATORS: David J. Gochis (NCAR), Ed Clark (NOAA/NWC), Drew Gronewold and Eric Anderson (NOAA GLERL/CILER), David N. Yates (NCAR), Andrew Wood (NCAR), Robert Cifelli (NOAA/PSD), Lynn Johnson (CIRA)

PROJECT OBJECTIVE:

This project will improve the representation of reservoir mass balance and storages in the operational NOAA National Water Model through the implementation and evaluation of a new reservoir level data assimilation scheme and new reservoir process representations. Beginning the summer of 2016, the NOAA National Water Center in partnership with the National Centers for Environmental Prediction, the National Center for Atmospheric Research and other academic partners will produce operational hydrologic predictions for the nation using a new NWM that is based on the community WRF-Hydro modeling system. This system will operationally produce a variety of hydrologic analysis and prediction products, including gridded fields of soil moisture, snowpack, shallow groundwater levels, inundated area depths, evapotranspiration as well as estimates of river flow and velocity for approximately 2.7 million river reaches. Also included in the NWM are representations of more than 1,200 reservoirs, which are linked into the national channel network defined by the USGS NHDPlusv2.0 hydrography dataset. Despite the unprecedented spatial and temporal coverage of the NWM, a number of known deficiencies exist in the representation of lakes and reservoirs, including no representation of the U.S. Great Lakes system. This project will address a set of these deficiencies through the implementation of a novel lake and reservoir level assimilation scheme and through the incorporation of additional lake and reservoir attribute information. The work directly builds upon the initial version of the NWM and will have direct benefit on future system upgrades as model representations are improved through the incorporation of additional real-time observations and improved process descriptions. Working with the NOAA Great Lakes Environmental Research Laboratory team, this project will develop and initial, simplified, baseline representation of the Great Lakes into the NWM upon which future development work can build. The new formulations implemented will be guided by, and evaluated, using ongoing NOAA Hydrometeorology Testbed data collection and modeling activities.

PROJECT ACCOMPLISHMENTS:

New Project. 1st report due to NOAA on April 30th.

PROJECT TITLE: Collaborative Research: Assessing Oceanic Predictability Sources for MJO Propagation

PRINCIPAL INVESTIGATOR(S): Charlotte A. DeMott, Department of Atmospheric Science, Colorado State University

RESEARCH TEAM: Charlotte A. DeMott, Department of Atmospheric Science, Colorado State University; Nicholas P. Klingaman, National Centre for Atmospheric Science, University of Reading, United Kingdom

NOAA TECHNICAL CONTACT: N/A

NOAA RESEARCH TEAM: N/A

PROJECT OBJECTIVE(S) (list 1 or more):

1. To understand how the prediction of strong MJO, weak MJO, and eastward-decaying MJO events is impacted by ocean feedbacks and the background ocean state.
2. To assess the importance of specific ocean feedback mechanisms to MJO prediction skill as a function of event type and MJO phase.
3. To develop a set of air-sea interaction diagnostics that will help clarify our understanding and quantify the impact of ocean feedbacks to the MJO.

PROJECT ACCOMPLISHMENTS: (Research Conducted) Past Fiscal Year by Objective:

Objective 1: We have identified roughly twelve each strong MJO, weak MJO, and eastward-decaying MJO events that developed during 1986-2013 ENSO- and Indian Ocean Dipole (IOD)-neutral years. Real-time Multivariate MJO (RMM) indices from the Subseasonal-to-Seasonal (S2S) database have been downloaded and are currently being reformatted into forecast day 1, day 2, etc. time series for each ensemble member of each participating model. Model skill for each MJO event type will be assessed for each model using standard metrics.

Each event type is associated with distinctly different upper ocean background states in the Indian Ocean (Figure 1): strong MJO events develop over the warmest SSTs and westward-flowing equatorial surface currents; weak MJO events develop over moderate SSTs and weak eastward-flowing equatorial currents; and decaying events develop over anomalously cold SSTs and strong eastward-flowing equatorial currents. The upper ocean background surface currents affect whether heating by solar radiation remains in the upper ocean, or is mixed downward, thereby limiting ocean feedbacks to MJO convection.

Objective 2: We are currently preparing a manuscript describing observed ocean feedbacks to each type of MJO event. These feedbacks include SST-wind-evaporation feedbacks to the MJO, SST gradient-driven boundary layer convergence, and rectification of upper ocean diurnal warm layers onto intraseasonal SST variability. The upper ocean background state will heavily influence the expression of these feedback mechanisms. These findings will serve as a basis for upcoming analysis of specific ocean feedback mechanisms present in S2S database forecast models and ensemble members, and how those feedbacks influence MJO prediction skill.

We have identified select MJO events (from the strong, weak, and eastward-decaying classifications) with both pronounced ocean feedbacks (as indicated by the SST anomaly amplitude) and with muted ocean feedbacks. Upcoming reforecast experiments using three coupled GCMs will test each of the aforementioned feedback processes to assess how each feedback mechanism affects forecast skill. Co-PI Klingaman is preparing scripts and experimental modeling frameworks to automate the process of running hindcast simulations.

Objective 3: A previously developed set of air-sea interaction diagnostics for the MJO for use with reanalysis data and climate-length model simulations is being adapted to reforecast model output. This adaptation will also rely on the reformatting of reforecast model output into day 1, day 2, etc. time series, but should otherwise enable application of the existing diagnostics developed for climate simulations.

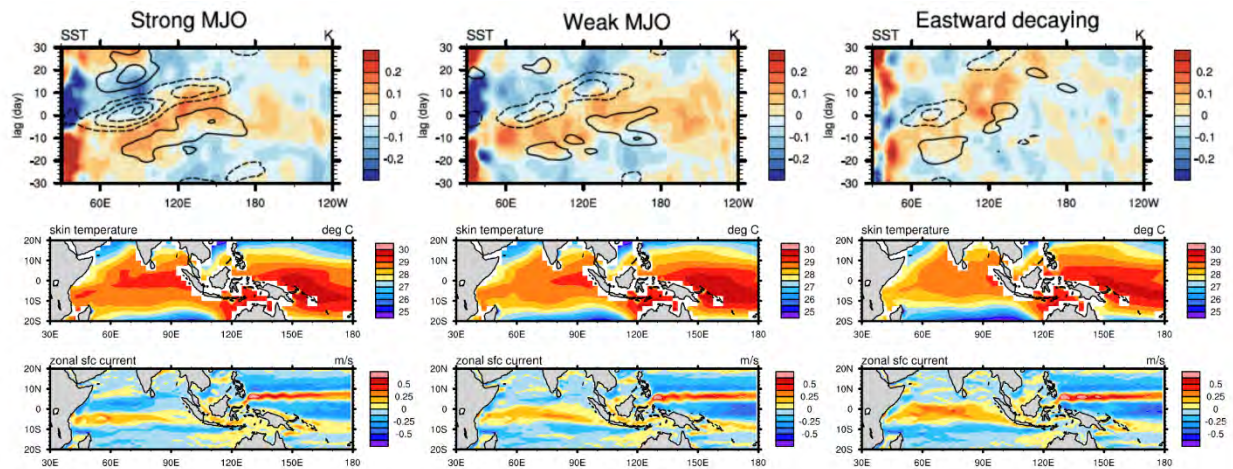

Figure 1. Top row: 10°S - 10°N averaged OLR (contours, interval 10 W m^{-2} ; negative values dashed) and SST anomalies (shaded) as a function of longitude and time for strong MJO, weak MJO, and eastward-decaying MJO events. Middle row: background (i.e., 61-day running mean centered on day 0) SST. Bottom row: background zonal surface currents.

Project Publications from Past Fiscal Year (including Conferences):

“Assessing SST feedbacks to the Madden-Julian oscillation in climate and forecast models” by Nicholas P. Klingaman and Charlotte A. DeMott, American Geophysical Union Fall Meeting, December 12-16, 2016, San Francisco, CA.

Project Title: Development of a Framework for Process-Oriented Diagnosis of Global Models

Project Number: GC15-106 (NA15OAR4310099)

PIs: Eric D. Maloney (Colorado State University), Andrew Gettelman (NCAR), Yi Ming (GFDL), David Neelin (UCLA)

Report Type: Year 2 Report

Results and Accomplishments

A. NOAA MAPP Model Diagnostics Task Force (MDTF) Activities

1. General Task Force Activities

The NOAA MAPP MDTF was initiated in Fall of 2015, led by chair Maloney, and co-chairs Gettelman, Ming, and Aiguo Dai. Regular telecons have been conducted on the first Monday of each month. The task force activities that have been initiated and are ongoing are described below.

2. NOAA MDTF Timeslice Experiments

Timeslice experiments have been completed with the NCAR and GFDL models to provide high time and space frequency resolution output to kick start task force diagnostics efforts. The specifications of this design are:

Timeslices of free running models

Specified SSTs: 1993-2012 with limited output, 2008-2012 with high frequency output

Models

NCAR (1 deg, possible short run of 0.25 deg)

GFDL (1 deg, possible short 0.5 deg run)

Output schemes

1. 20-year (1993-2012) simulation: Daily, a handful set of 2D variables

2. 5-year (2008-2012) sub period: 6-hourly, comprehensive list

3. 2-year (2011-2012) sub period: hourly, variables for diurnal cycle study

Both NCAR and GFDL have completed these experiments. These simulations are in the process of being posted to the Earth System Grid, and will be assigned their own DOI with the title of Model Diagnostics Task Force Timeslice Experiments. These experiments will form the basis for a MDTF diagnostics intercomparison and possible foundation for comprehensive manuscripts in future years.

3. Implementation of convective onset diagnostics at GFDL and NCAR

Convective onset diagnostics developed by co-PI Neelin have been implemented at GFDL and NCAR, and serve as the initial test diagnostic for the diagnostic framework (discussed in 4 below). PI Ming at GFDL reports that this diagnostic suite is already being used as an important performance metric and is having a direct impact on model development at GFDL and efforts to freeze the next generation of the GFDL model for CMIP6. NCAR is also using the metrics in its

CMIP6 model development activity that is currently wrapping up. Improvements to the diagnostics are discussed in section B.

4. Development of Diagnostics Software Framework/Application Programming Interface (API)

Based on discussions among our Type 1 team and the task force, and given input from others external to the task force including V. Balaji and Erik Mason at GFDL, and members of the WGCM community, we developed an initial Application Programming Interface (API), or guidance for use of diagnostics in the NCAR and GFDL workflows. A Python-based code infrastructure for implementation and output of these diagnostics has been developed. The basic structure uses a Python driver to call a series of diagnostic packages or modules to develop graphics and then output them to a common website. The resulting plots will be pulled together into common web pages by the driver (NCAR) or by the overall workflow (GFDL). The prototype shell script in Python works with diagnostics code developed in NCL, Python, Fortran or any other open source graphics package. The diagnostic modules has access to data structures and arguments from Python, and outputs a standard plot type (png) to a location where it can be used to construct web pages by the driver.

A schematic of the proposed GFDL and NCAR workflows is shown here:

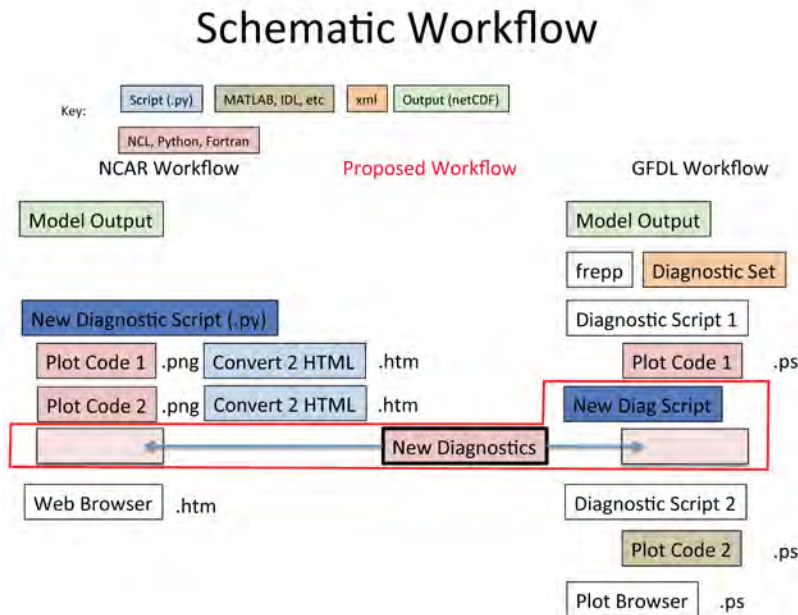

The diagnostics website that will be populated by diagnostic results is shown here:

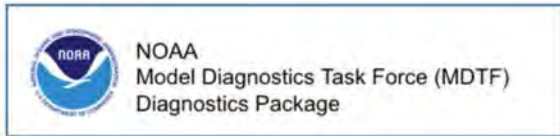

MDTF Variability Diagnostics

EOF of geopotential height anomalies for 500 hPa f.e20.F2000_DEV.f09_f09.CLUBB_reorder_n05_cam5_4_96 OBS

North Atlantic

[plot](#)

[plot](#)

North Pacific

[plot](#)

[plot](#)

5) Moist static energy budget subgroup

A subgroup of the MDTF is devoted to easing calculation of the vertically-integrated moist static energy (MSE) budgets in the GFDL, NCAR, and other models for storage efficiency and accuracy, and also for preventing duplication of efforts given the interest in such diagnostics on the part of several groups. PI Maloney is the point of contact with the modeling centers on such efforts. Ming Zhao at GFDL has been able to close the vertically-integrated MSE budget within code and this closed budget has been applied for understanding the dynamics of the MJO in development versions of the GFDL model. This code will be made available for frozen versions of the CMIP6 implementation of the GFDL model for possible inclusion in timeslice experiments described above. Jack Chen at NCAR has developed a novel technique to calculate the frozen MSE budget by defining frozen MSE as a new tracer variable and integrating the tracer transport equation, and is working with the NCAR model to develop in-code vertically-integrated budgets. Lessons learned from the efforts at GFDL to calculate the MSE budget will be translated to NCAR.

6) Session at 2016 AGU Meeting and other Meetings

A session on process-oriented diagnostics was conducted at the 2016 AGU meeting in San Francisco. PI Maloney submitted the proposal in April. This meeting served as a venue for a face-to-face meeting of the entire MDTF, who has a Monday evening dinner. Unfortunately, the PI Maloney has to cancel his trip to AGU because of an extended hospital visit, but the meeting among the rest of the TF members was nonetheless productive. The PIs on the Type 1 team also visited to GFDL in November in association with the WCRP Model Hierarchies workshop, and PI Maloney visited GFDL in February to give a seminar and have discussions with co-PI Ming and GFDL scientist Ming Zhao.

7) AMS Special Collection

A special collection on process-oriented diagnostics was submitted and accepted by AMS publications that reports on and synthesizes the work of our task force. The special collection description is included here: The special collection will span journals including *Bulletin of the American Meteorological Society (AMS)*, *Journal of Climate*, *Journal of the Atmospheric*

Sciences, and *Journal of Hydrometeorology* devoted to process-oriented evaluation of climate and Earth system models. The Model Diagnostics Force (MDTF) of the NOAA Modeling, Analysis, Predictions, and Projections Program (MAPP) will organize this special collection. This special collection is motivated by community interest in moving beyond performance-oriented metrics toward process-oriented metrics of models, current efforts to develop the next generation of climate and Earth system models including those related to the Coupled Model Intercomparison Project (CMIP), and a need to link model development and evaluation efforts across modeling centers. Assessing processes in climate and Earth system models is essential for understanding model biases, identifying model error origins, and developing next-generation models.

The centerpiece of the special collection will consist of a comprehensive article in the *AMS Bulletin* that gives background on the concept of process-oriented model diagnosis, provides a partial summary of previous efforts at process-oriented diagnosis including both individual and organized efforts such as the European EMBRACE project, highlights key diagnostics developed by the MDTF, and describes an integrative process-oriented metrics framework serving multiple modeling centers that is being developed under the NOAA MAPP MDTF. Papers in *Journal of Climate*, *Journal of the Atmospheric Sciences*, and *Journal of Hydrometeorology* would provide the scientific details of specific process-oriented diagnostics accompany this core study. These papers detail studies not only by MDTF members, but also those contributed by the broader community.

8) 2017 WGNE Systematic Errors Workshop

The MDTF is co-organizing the 5th WGNE workshop on systematic errors in weather and climate models to be held 19-23 June, 2017 in Montreal, Canada. A dedicated session on model metrics and diagnostics will take place at this meeting, including a substantial number of contributions from the MDTF. The MDTF will have a dedicated side meeting on June 23, part of which will be held coincident with the WGNE MJO Task Force.

B. Research Activities

Improvement of the convective onset diagnostics and application to understanding convective physics (Kuo et al. 2017)

Previous work by various authors has pointed to the role of lower free-tropospheric humidity in affecting the onset of deep convection in the tropics. Empirical relationships between column water vapor (CWV) and precipitation have been inferred to result from these effects. Evidence from previous work has included deep-convective conditional instability calculations for entraining plumes, in which the lower free-tropospheric environment affects the onset of deep convection due to the differential impact on buoyancy of turbulent entrainment of dry versus moist air. The relationship between deep convection and water vapor is, however, a two-way interaction because convection also moistens the free troposphere. One might thus argue that the causality of the precipitation-water vapor relationship has not yet been fully established. Parameter perturbation experiments using the coupled Community Earth System Model (CESM) with high time-resolution output are analyzed for a set of statistics for the transition to deep convection, coordinated with observational diagnostics for GOAmazon and Tropical Western Pacific Atmospheric Radiation Measurement (ARM) sites. For low values of entrainment in the

deep convective scheme, these statistics are radically altered and the observed pickup of precipitation with CWV is no longer seen. In addition to cementing the dominant direction of causality in the fast-timescale precipitation-CWV relationship, the results point to impacts of entrainment on the climatology. Because at low entrainment convection can fire before tropospheric moistening, the climatological values of relative humidity are lower than observed. These findings can be consequential to biases in simulated climate and to projections of climate change.

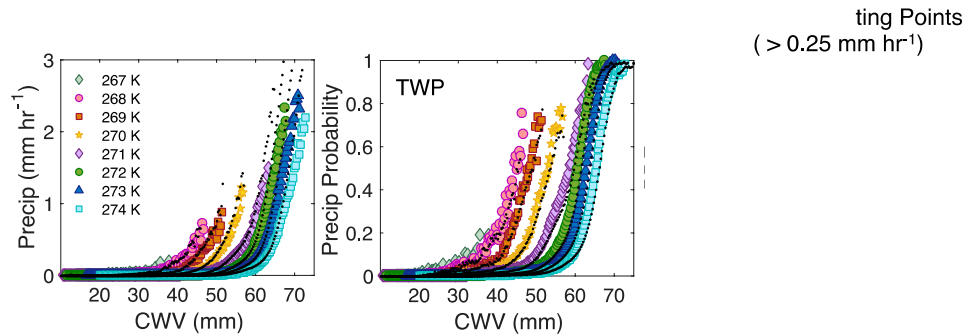

Figure 1. Resolution dependence of several convective onset statistics from TRMM Microwave Imager retrievals: (a)-(c) averaged to 0.5° ; (d)-(f) averaged to 1.5° . The results from native 0.25° retrievals are overlaid in small black dots in each panel. (a) & (d) the pickup of precipitation (conditionally averaged by CWV and tropospheric average temperature); (b) & (e) probability of precipitation (larger than a threshold of 0.25 mm/hr); (c) & (f) the probability density function of precipitating points. (Analysis Y.H. Kuo & K. Schiro).

New weak temperature gradient diagnostics for the MJO applied to models (Wolding et al. 2016)

New process-oriented diagnostics using the concept of weak tropical temperature gradients are being developed and have been applied to understand the dynamics of the Madden-Julian oscillation in several climate models, and to understand their biases. These diagnostics can be applied in three dimensions, and extend the 2-D moist static energy budget diagnostics that have been used by the PI and collaborators over the last several years. These higher order diagnostics are being prepared for inclusion in the diagnostics packages of NCAR and GFDL, with the hope of broader application across a more extensive suite of models. We discuss some application of these diagnostics here to the Sp-CESM, although these have been also applied to other models such as the Ocean Land Atmosphere Model (OLAM).

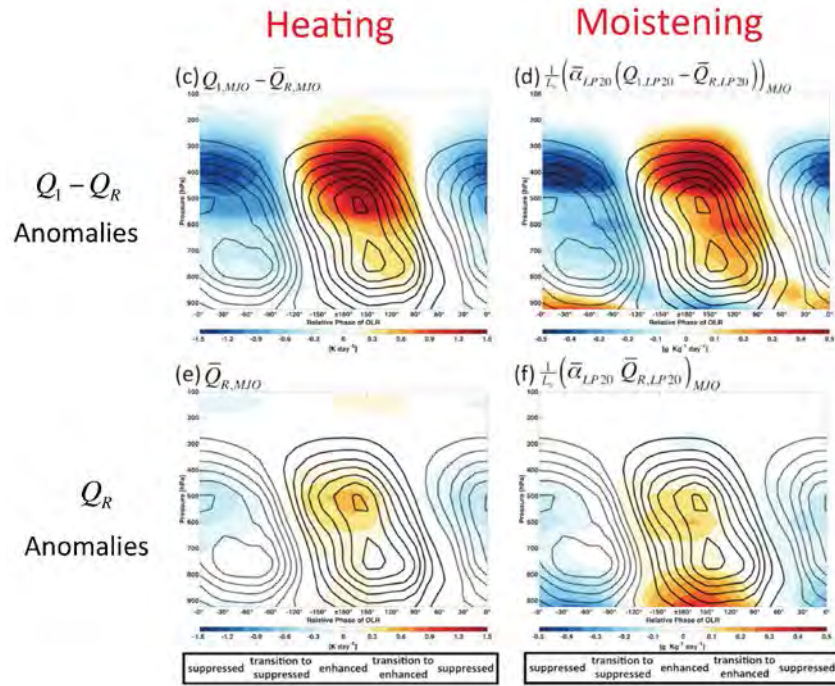

Figure 2. Composite vertical structure of condensational heating and radiative heating anomalies (left) and their moistening effect as determined through the assumption of WTG balance (right).

The collective effects of convection can influence large-scale circulations that, in turn, act to organize convective activity. Such scale interactions may play an important role in moisture-convective feedbacks thought to be important to both convective aggregation and the Madden-Julian Oscillation, yet such interactions are not fully understood. New diagnostics based on tropical weak temperature gradient (WTG) theory have begun to make this problem more tractable, and are leveraged in this study to analyze the relationship between various apparent heating processes and large-scale vertical motion in SP-CESM. WTG theory provides a framework for accurately diagnosing intraseasonal variations in large-scale vertical motion from apparent heating, allowing large-scale vertical moisture advection to be decomposed into contributions from microphysical processes, subgrid scale eddy fluxes, and radiative heating. This approach is consistent with the column moist static energy (MSE) budget approach, and has the added benefit of allowing the vertical advection term of the column MSE budget to be quantitatively partitioned into contributions from the aforementioned apparent heating processes. This decomposition is used to show that the MJO is an instability strongly supported by radiative feedbacks (**Figure 2d**) and damped by horizontal advection, consistent with the findings of previous studies. Periods of low, moderate, and high MJO amplitude are compared, and it is shown that changes in the vertical structure of apparent heating do not play a dominant role in limiting the amplitude of the MJO in SP-CESM. Finally, a diagnostic approach to scale analysis of tropical dynamics is used to investigate how the governing dynamics of various phenomena differ throughout wavenumber-frequency space. Findings support previous studies that suggest the governing dynamics of the MJO differ from those of strongly divergent convectively coupled equatorial waves. This paper is published in the AGU journal *Advances in Modeling Earth Systems*.

Climate change and the Madden-Julian Oscillation: A vertically resolved weak temperature gradient analysis (Wolding et al. 2017)

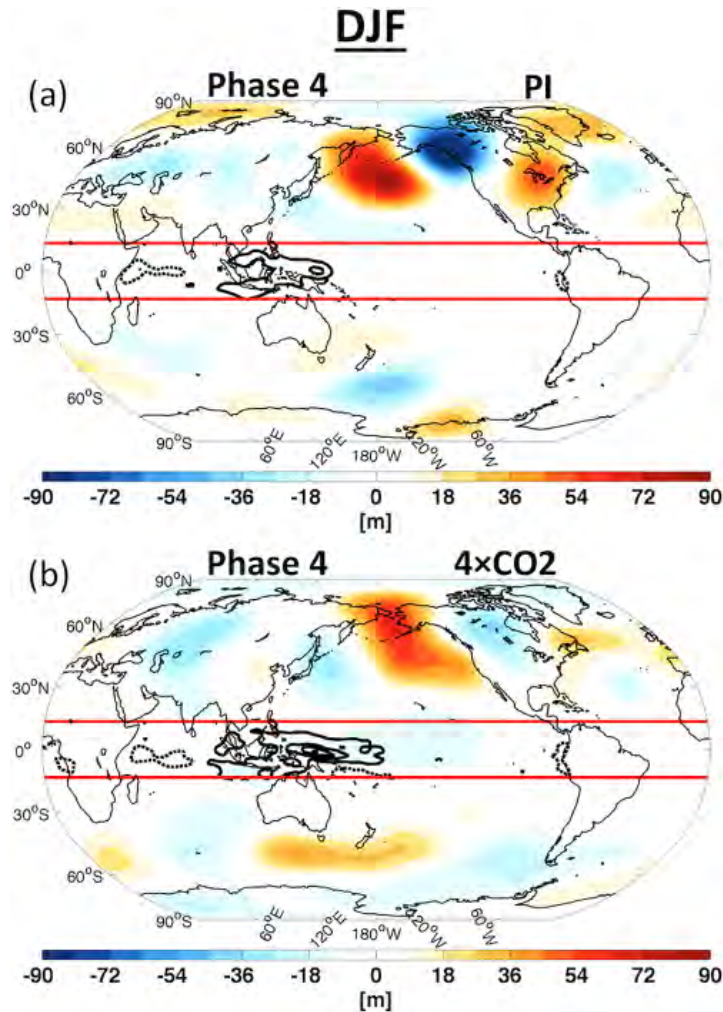

Figure 3. DJF phase 4 composites of 20–100 day band-pass filtered column-averaged apparent heating anomalies (contours) in the tropics, and 20–100 day band-pass filtered 525 hPa geopotential height anomalies (color shading) in the extratropics for the (a) pre-industrial and (b) 4×CO₂ simulations. Red lines at 15°N and 15°S denote the boundaries used for tropical and extratropical averaging in the corresponding analysis. Solid and dashed contours correspond to positive and negative heating rates, respectively, contoured every 2 Kd⁻¹ starting at ±1 Kd⁻¹, with the 0 Kd⁻¹ contour omitted.

WTG balance diagnostics are used to examine how changes in the moist thermodynamic structure of the tropics affect the MJO in two simulations of the Superparameterized Community Earth System Model (SP-CESM), one at preindustrial (PI) levels of CO₂ and one where CO₂ levels have been quadrupled (4×CO₂). While MJO convective variability increases considerably in the 4×CO₂ simulation, the dynamical response to this convective variability decreases. Increased MJO convective variability is shown to be a robust response to the steepening vertical moisture gradient, consistent with the findings of previous studies. The steepened vertical moisture gradient allows MJO convective heating to drive stronger variations in large-scale vertical moisture advection, supporting destabilization of the MJO. The decreased dynamical response to MJO convective variability is shown to be a consequence of increased static stability, which allows weaker variations in large-scale vertical velocity to produce sufficient adiabatic cooling to balance variations in MJO convective heating. This weakened dynamical response results in a considerable reduction of the MJO's ability to influence the extratropics, which is closely tied to the strength of its associated divergence. A composite lifecycle of the MJO was used to show that northern hemisphere extratropical 525 hPa geopotential height anomalies decreased by 27% in

the $4\times\text{CO}_2$ simulation, despite a 22% increase in tropical convective heating associated with the MJO (**Figure 3**). Results of this study suggest that while MJO convective variability may increase in a warming climate, the MJO's role in “bridging weather and climate” in the extratropics may not.

Madden-Julian Oscillation Pacific teleconnections: The impact of the basic state and MJO representation in General Circulation Models (Henderson et al. 2017)

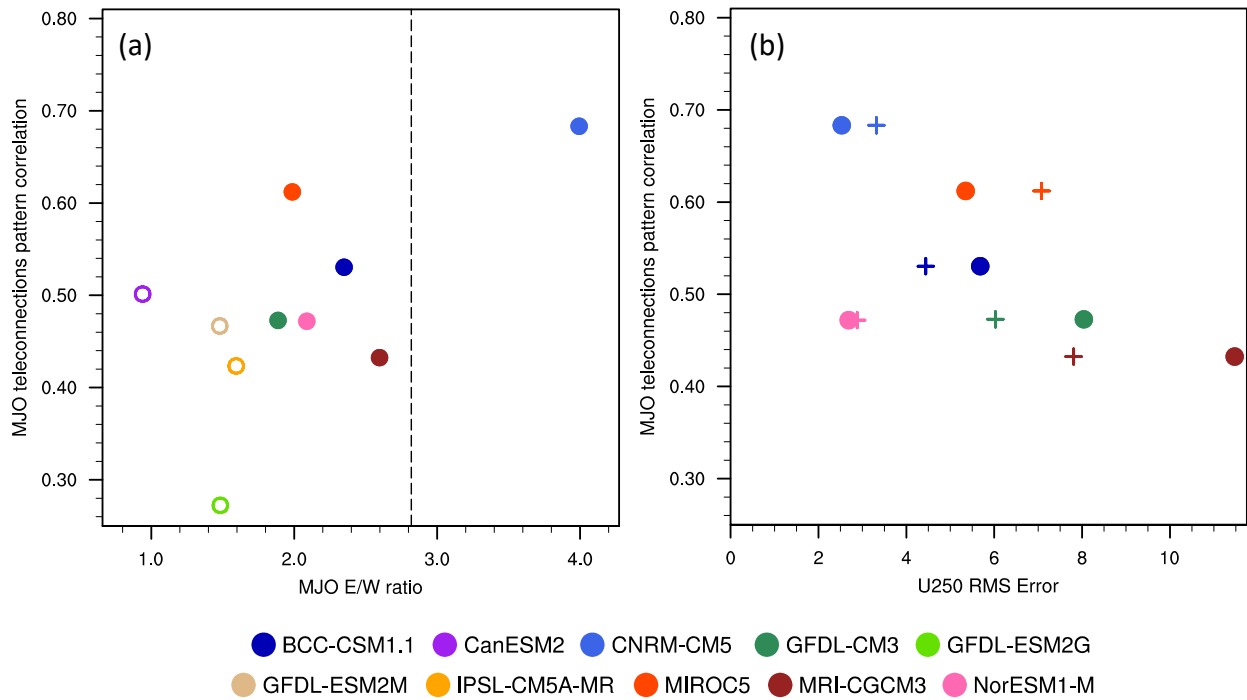

Figure 4. Teleconnection pattern correlation averaged for all MJO phases (y-axes) relative to the (a) MJO E/W ratio and (b) the 250-hPa mean zonal wind RMS error. In panel (a), the dashed line indicates the observed E/W ratio, and the open circles represent the poor MJO models. In panel (b), the plus signs show the model zonal wind RMS error over the full Pacific basin, while the filled circles indicate the longitudinal RMS error in the region of the subtropical jet.

Teleconnection patterns associated with the Madden-Julian Oscillation (MJO) significantly alter extratropical circulations, impacting weather and climate phenomena such as blocking, monsoons, the North Atlantic Oscillation, and the Pacific-North American pattern. However, the MJO has been extremely difficult to simulate in many General Circulation Models (GCMs), and many GCMs contain large biases in the background flow, presenting challenges to the simulation of MJO teleconnection patterns and associated extratropical impacts. In this study, the database from phase 5 of the Coupled Model Intercomparison Project (CMIP5) is used to assess the impact of model MJO and basic state quality on MJO teleconnection pattern quality, and a simple dry linear baroclinic model is employed to understand the results. Even in GCMs assessed to have good MJOs, large biases in the MJO teleconnection patterns are produced due to errors in the zonal extent of the Pacific subtropical jet. The horizontal structure of Indo-Pacific MJO heating in good MJO models is found to have modest impacts on the teleconnection

pattern skill, in agreement with previous studies that have demonstrated little sensitivity to the location of tropical heating near the subtropical jet. However, MJO heating east of the Dateline can alter the teleconnection pathways over North America. Results show that GCMs with poor basic states can have equally low skill in reproducing the MJO teleconnection patterns as GCMs with poor MJO quality, suggesting that both the basic state and the MJO must be well represented in order to reproduce the correct teleconnection patterns (Figure 4).

Effects of the changing heating profile associated with melting layers in a climate model (Zhu et al. 2017)

This study investigates the impact of modifying the melting behaviour at the freezing level in the GA2.0 version of the Met Office UM. It finds that by allowing snow to melt over a greater depth, biases in rainfall over the Maritime Continent (MC) are improved, and there is an indication of benefits to the MJO.

This study uses moistening diagnostics under weak temperature gradient theory to explain how and why changes to the treatment of melting influence tropical rainfall biases. The modified melting experiment increases the lower tropospheric diabatic heating rate per unit column-integrated convective heating in the MC, which helps to increase lower tropospheric vertical moisture advection per unit column convective heating, making conditions more favorable for convection there. Changes of the opposite sense occur in tropical ocean regions of the west Pacific and Indian Ocean. Changes in lower tropospheric radiative heating per unit convection produced by the different treatment of melting are particularly influential in engendering mean precipitation changes between the experiments. Differences in precipitation in the MC region between the control and melting experiments and opposite changes in oceanic regions to the east and west are linked through changes in the Walker circulation, making it unclear which region is most influential for forcing the improvement in the pattern of precipitation biases. Sensitivity experiments that artificially enhance convection in one region through imposition of SST anomalies produce a negative precipitation response in the other region.

C. Highlights of Accomplishments

- Accomplishments of the MDTF task force to date include:
 - Implementation of convective onset diagnostics into the GFDL and NCAR models
 - Development of a draft application programming interface to enable rapid dissemination of diagnostics across models,
 - Completion of simulations for timeslice experiments with the GFDL and NCAR models,
 - Closing the MSE budget in the GFDL model
 - Successful proposal for an AMS special collection on process-oriented diagnostics
 - A successful special session on diagnostics at the 2016 AGU meeting
- 3-D process oriented diagnostics to understand MJO moistening processes based on weak tropical temperature gradients have been developed and successfully applied to SP-CESM and other models. These diagnostics build on the 2D MSE budget diagnostics developed by the PI and collaborators

- Process-oriented diagnostics have been developed to document and understand reasons for poor MJO teleconnections in CMIP models
- Modeling results suggest that the MJO teleconnection to the extratropics may weaken in future climate

D. Publications From the Project

- Kuo, Y.H., C. R. Mechoso and J. D. Neelin, 2017: Tropical convective onset statistics and establishing causality in the water vapor-precipitation relation. *J. Climate*, accepted.
- Henderson, S. A., E. D. Maloney, and S.-W. Son, 2017: Madden-Julian oscillation teleconnections: The impact of the basic state and MJO representation in general circulation models. *J. Climate*, in press.
- Wolding, B. O., E. D. Maloney, S. A. Henderson, and M. Branson, 2016: Climate Change and the Madden-Julian Oscillation: A Vertically Resolved Weak Temperature Gradient Analysis. *J. Adv. Modeling Earth Sys.*, **9**, doi:10.1002/2016MS000843.
- Wolding, B. O., E. D. Maloney, and M. Branson, 2016: Vertically Resolved Weak Temperature Gradient Analysis of the Madden-Julian Oscillation in SP-CESM. *J. Adv. Modeling. Earth. Sys.*, **8**, doi:10.1002/2016MS000724.
- Zhu, H., E. Maloney, H. Hendon and R. Stratton, 2017: Effects of the changing heating profile associated with melting layers in a climate model. *Q. J. Royal. Met. Soc.*, accepted pending revision.

E. PIs Contact Information

Eric D. Maloney (lead PI)
 Department of Atmospheric Science
 Colorado State University
 1371 Campus Delivery
 Fort Collins, CO 80523-1371
 Phone: (970) 491-3368
emaloney@atmos.colostate.edu

Yi Ming (co-PI)
 NOAA Geophysical Fluid Dynamics
 Laboratory
 Princeton University, 201 Forrestal Rd^[SEP]
 Princeton, NJ 08542
 Phone: 609-452-5338
Yi.Ming@noaa.gov^[SEP]^[SEP]

Andrew Gettelman (co-PI)
 National Center for Atmospheric Research
 PO Box 3000,
 Boulder, CO 80307-3000
 Phone: (303)497-1887
andrew@ucar.edu

J. David Neelin (co-PI)
 Dept. of Atmospheric and Oceanic Sciences
 University of California, Los Angeles
 405 Hilgard Ave.
 Los Angeles, CA 90095-1565
 Phone: 310-206-3734
neelin@atmos.ucla.edu

F. Budget for the Coming Year

The budget for the coming year is unchanged from that in the submitted proposal.

G. Future Work

The plan for future work includes that in the original proposal, although with the inclusion of significant extensions. Extensions of the originally proposed work include maintenance and

possible expansion of the MDTF timeslice simulations, development of an in-code framework for calculation of the vertically-integrated MSE budget in the NCAR and GFDL models, organization of the 2017 WGNE systematic errors meeting in Montreal, and generation of an AMS special collection on process-oriented diagnostics.

Annual Progress Report

Following emissions from Non-Traditional Oil and Gas Development Through their Impact on Tropospheric Ozone

Award Number: NA14OAR4310148
Principal Investigator: Dr. Emily V. Fischer
Institution: Colorado State University, Fort Collins, CO 80521
Co-investigators: Dr. Delphine K. Farmer, Dr. Chris Kummerow
Start Date: August 1, 2014
Period Covered: May 30, 2016 – March 15, 2017

I Project Statement

This project is focused on investigating how emissions from current oil and gas development are changing patterns of tropospheric ozone production at the local, continental and global scale. The proposed work tackles these scientific questions:

1. What are characteristic ozone production rates and efficiencies in air masses influenced by emissions from oil and gas production?
2. To what extent have emissions from oil and gas production impacted the extent of NO_x versus NMVOC limited ozone production?
3. Through which chemical pathways do emissions from oil and gas production propagate most efficiently to global ozone production?
4. How do emissions from this sector affect radiative forcing through perturbations to tropospheric ozone, methane, and remote aerosol formation?

II Accomplishments

Summary: Significant progress has again been achieved during the third year of research including (A) publication of a manuscript focused on global fossil fuel emissions of ethane [Tzompa-Sosa *et al.*, 2017] and their impact on ozone, (B) publication of a manuscript that includes the analysis of the springtime and summertime volatile organic compounds (VOCs) observed during the measurement intensives [Abeleira *et al.*, 2017], (C) submission of a manuscript focused on the impact of different VOC sources on local ozone and organic nitrogen formation [Emerson *et al.*, in review, JGR], (D) submission of a manuscript focused on the long term trends in ozone and NO_x over the Colorado Front Range and the implications for NO_x versus VOC limited ozone production [Abeleira and Farmer, in review, ACP], and (E) submission of a manuscript focused on the impact of aged wildfire smoke on photochemistry in the Colorado Front Range based on observations of a major smoke event during our summer 2015 field campaign [Lindaas *et al.*, in review, ACP]. We request a no-cost extension to this project to support the publication fees associated with the three manuscripts that are currently in review, and to support publication fees associated with two additional manuscripts underway. We also expect two additional manuscripts based on on-going analysis of individual ozone events in summer 2015 [Lindaas *et al.*, in prep], and a new modeling analysis of the impact of the emissions of oil and gas on ozone and reactive nitrogen partitioning on a national scale [Tzompa-Sosa *et al.*, in prep]. The latter analysis required implementing a new version of the NEI 2011 (version ek) with significantly improved emissions from the oil and gas sector into GEOS-Chem, and thus has involved major additional efforts. These are both primarily student-led manuscripts, but we conservatively expect them to be ready for submission in late summer.

(A) *Summary of Tzompa-Sosa et al. [2017]*

This paper presents an updated global ethane emission inventory based on 2010 satellite-derived methane fluxes with adjusted ethane emissions over the U.S. from the NEI 2011. The year 2010 represents the start of the most recent period of large increases in the abundance of ethane in the Northern Hemisphere. We contrast our global 2010 ethane emission inventory with one developed for 2001. We show that the difference between global anthropogenic emissions of ethane is subtle for these two time periods (7.9 versus 7.2 Tg yr⁻¹), but the spatial distribution of the emissions is very different. In the 2010 ethane inventory, fossil fuel sources in the Northern Hemisphere represent half of global ethane emissions and 95% of global fossil fuel emissions. We compiled a large suite of aircraft and surface ethane measurements, including our own. Over the U.S., unadjusted NEI 2011 ethane emissions produce mixing ratios that are 14–50% of those observed by aircraft observations (2008–2014). When the NEI 2011 ethane emission totals are scaled by a factor of 1.4, the GEOS-Chem model largely reproduces observations over the U.S., with the exception of the central U.S., where it continues to under-predict observed mixing ratios in the lower troposphere.

(B) *Summary of Abeleira et al., [2017]*

This paper is the first in a series of papers presenting the results from the field measurements at the Boulder Atmospheric Observatory (BAO) supported by this grant over 16 weeks in spring and summer 2015. *Abeleira et al. [2017]* presents an analysis of hourly measurements of >40 VOCs. We find that the average mid-day VOC reactivity at BAO is lower than most other U.S. urban sites. However, this region is also more strongly influenced by VOCs from sources related to oil and natural gas development than other urban and suburban regions of the U.S. that have been recently observed. We completed a positive matrix factorization (PMF) analysis, and this analysis identified five VOC factors in the spring corresponding to sources from (1) long lived oil and natural gas (ONG-Long Lived), (2) short lived oil and natural gas (ONG-Short Lived) (3) traffic, (4) background and (5) secondary chemical production. In the summer, an additional biogenic factor was dominated by isoprene. ONG-related VOCs were the single largest contributor to the calculated VOC reactivity in the morning in both spring and summer (40 – 60 %). We observed a biogenic factor in summer that was substantially enhanced in the afternoon and evening, contributing an average of 21% of the VOC reactivity, but up to 49%. The results from 2015 are in contrast to previous NOAA measurements in summer 2015 at BAO where biogenic species contributed <10% of the VOC reactivity on average. We link these differences to differences in drought stress between the two summer seasons.

(C) *Summary of Emerson et al. [in review at JGR]*

We made speciated measurements of reactive nitrogen oxides (NO_y) at BAO along with the VOC measurements discussed above. Speciating NO_y informs the chain termination steps in ozone formation and provides insight into how VOC mixtures propagate catalytic cycles. Our summer 2015 measurements included NO, NO₂, peroxyacyl nitrates, nitric acid, and short-chain (C₁-C₅) alkyl nitrates. This paper shows that a substantial (up to 40% and 1.6 ppbv) component of ‘missing NO_y’ is observed between sunrise and 2 PM. We attribute this ‘missing NO_y’ to unmeasured organic nitrates (RONO₂). Observations of odd oxygen (O_x ≡ O₃ + NO₂) and ‘missing NO_y’ allow us to infer a branching ratio for organic nitrate formation (α) of 0.10±0.01. This is larger than α calculated from the measured VOCs ($\alpha_{\text{calc}} = 0.06 \pm 0.01$). The inferred and calculated branching ratios based on the summer 2015 BAO data are relatively high due to the influence of hydrocarbons associated with oil and natural gas development. The paper uses the six source factors from the PMF analysis in *Abeleira et al. [2017]*, to determine α_{calc} values for long-lived ONG (0.08), short-lived ONG (0.09), traffic (0.06), secondary oxidation products (0.02), background (0.004), and biogenic (0.07) sources. These calculated branching ratios indicate that the traffic factor has a lower branching ratio, and thus VOCs in this source factor more efficiently

produce ozone. However, the extreme high abundance of ONG and the high reactivity of biogenic emissions actually make them the dominant contributors to the production of both odd oxygen and unspeciated organic nitrates during this time period.

(D) Summary of Abeleira and Farmer et al. [in review at ACP]

This paper uses available long-term ozone and NO_x data from across the Northern Colorado Front Range Metropolitan Area to investigate trends in these species. The broad trends from 2000 to 2015 in the Front Range are largely consistent with previous analyses of the region. The abundance of NO_x declined over this period; however the abundance of ozone is stagnant or increasing at individual monitoring sites. There is a strong weekend-weekday effect reflected in the data, and this is consistent with the region being NO_x-saturated. However the weekend-weekday effect has been decreasing in strength as NO_x has decreased, and the paper proposes that this indicates that the region is near peak ozone production. Two of the long-term monitoring sites included in the analysis show flipped weekend-weekday effects in recent years, and this implies that local NO_x may have decreased sufficiently at those sites such that they reflect NO_x-limited conditions. The paper also shows that ozone in this region has a strong temperature-dependence, but that this relationship is suppressed in years with drought stress. This pattern supports the view that biogenic VOCs do impact ozone production in the region, and places the *Abeleira et al.* [2017] VOC measurements in a long-term context.

(E) Summary of Lindaas et al. [in review at ACP]

We observed two distinct periods where aged wildfire smoke impacted BAO during summer 2015: 6–10 July and 16–30 August. The smoke we observed at BAO was transported from the Pacific Northwest and Canada and it was several days old when it reached Colorado. This smoke also impacted the atmospheric column across much of the continental U.S. This paper contrasts the smoke-free and smoke-impacted in situ observations from BAO during summer 2015. In addition to increases in carbon monoxide (CO) and particulate matter, the smoke impacted periods also showed elevated mixing ratios of peroxyacyl nitrates and several VOCs with atmospheric lifetimes longer than the transport timescale of the smoke. The data also showed that the abundance of short-lived alkenes were depressed during the smoke-impacted periods. During the two-week long August smoke-impacted period, NO₂ was also elevated during the morning and evening compared to the smoke-free periods. Given our measurement suite, we are unable to identify a mechanism associated with this increase, though it is statistically significant. There were six days during our study period where the maximum 8-hour average ozone at BAO was greater than 65 ppbv, and two of these days were smoke-impacted. We examined the relationship between ozone and temperature and found that for a given temperature, ozone mixing ratios were ~10 ppbv greater during the smoke-impacted periods. Enhancements in ozone during the August smoke-impacted period were also observed at two nearby sites located within Colorado, but outside the polluted Front Range urban corridor: Rocky Mountain National Park and the Arapahoe National Wildlife Refuge. These data provide a new case study of how aged wildfire smoke can influence atmospheric composition at an urban site, and we were fortunate to capture these periods of smoke-influence with such an extensive suite of gas-phase observations. This paper will certainly be helpful in shaping the upcoming smoke-focused field intensives anticipated in summer 2018 and 2019.

III Plan for Requested No-Cost Extension Period

As mentioned in the summary, we are preparing two additional manuscripts based on on-going analysis of individual ozone events in summer 2015 [*Lindaas et al.*, in prep], and a new GEOS-Chem analysis of the impact of the emissions of oil and gas on ozone and reactive nitrogen partitioning on a national scale [*Tzompa-Sosa et al.*, in prep]. *Lindaas et al.* [in prep] presents observationally based estimates of ozone production efficiency (OPE) for several periods of

enhanced ozone in summer 2015. We generally find higher OPE than the mean from the 2014 FRAPPE period [McDuffie *et al.*, 2016]. We are examining the composition of time periods with rapid changes in ozone. We find that rapid rises in ozone are associated with a high PPN: PAN ratios, and other smoke-free high ozone days display PPN: PAN ratios > 0.15 . This PPN: PAN ratio has been observed in other areas dominated by anthropogenic VOC-NO_x photochemistry, and it implies that isoprene chemistry may not have been very important on the highest ozone days in 2015. Finally, Tzompa-Sosa *et al.* [in prep] is a modeling study that includes the latest version of the 2011 National Emission Inventory (2011v6.3 ek). We felt it was important to implement this version of the NEI into GOS-Chem because it includes updates over important oil and natural gas basins and speciation profiles based on the Western Regional Air Partnership. This was not available previously, but we received the appropriate input files early in 2017 via collaboration with Dr. Barron Henderson at the EPA. We are using GEOS-Chem to simulate the atmospheric abundances of C₂-C₅ alkanes over the U.S. attributed to emissions from the oil and gas sector. We are evaluating our simulation by comparing it to a suite of surface in situ observations, column measurements, and aircraft profiles. Finally, we are now able to make a more robust estimate of the contribution that C₂-C₅ alkanes make to the abundances of important secondary species including ozone, peroxy acetyl nitrate, and several ketones. Again, these final two papers are both primarily student-led manuscripts, but we conservatively expect them to be ready for submission in late summer. We request a one-year no-cost extension to cover publication charges over the next year.

IV Presentations and Accepted/Submitted Publications for this Period

Publications:

Abeleira, A. A. and Farmer, D. K.: Summer ozone in the Northern Front Range Metropolitan Area: Weekend-weekday effects, temperature dependences and the impact of drought, *Atmos. Chem. Phys. Discuss.*, doi:10.5194/acp-2017-160, in review, 2017.

Abeleira, A., I. B. Pollack, B. Sive, Y. Zhou, E. V. Fischer, and D. K. Farmer (2017), Source Characterization of Volatile Organic Compounds in the Colorado Northern Front Range Metropolitan Area during Spring and Summer 2015, *J. Geophys. Res. Atmos.*, 122, doi:10.1002/2016JD026227.

Emerson, E. W., E. V. Fischer, I. B. Pollack, A. Abeleira, R. Roscioli, S. Herndon, J. Lindaas, F. Flocke, and D. K. Farmer, Impact of Different VOC Sources on Organic Nitrates and the Reactive Nitrogen Oxide Budget (submitted), *J. Geophys. Res. Atmos.*, in review.

Lindaas, J., Farmer, D. K., Pollack, I. B., Abeleira, A., Flocke, F., Roscioli, R., Herndon, S., and Fischer, E. V.: The impact of aged wildfire smoke on atmospheric composition and ozone in the Colorado Front Range in summer 2015 (submitted), *Atmos. Chem. Phys. Discuss.*, doi:10.5194/acp-2017-171, in review, 2017.

Tzompa-Sosa, Z. A., E. Mahieu, B. Franco, C. A. Keller, A. Turner, D. Helmig, A. Fried, D. Richter, P. Weibring, J. Walega, T. I. Yacovich, S. C. Herndon, D. R. Blake, F. Hase, J. W. Hannigan, S. Conway, K. Strong, M. Schneider and E. V. Fischer (2017), Revisiting global fossil fuel and biofuel emissions of ethane, *J. Geophys. Res. Atmos.*, 122, doi:10.1002/2016JD025767.

Presentations:

Abeleira, A. J., Sive, B., Pollack, I. B., Zaragoza, J., Lindaas, J., Fischer, E. V., Farmer, D. K., American Geophysical Union Fall Meeting, "Sources and Seasonality of Volatile Organic

Compounds in the Northern Front Range Metropolitan Area," San Francisco, CA, United States. (December 2016).

Emerson, E. W., Abeleira, A. J., Pollack, I. B., Lindaas, J., Flocke, F. M., Herndon, S., Roscioli, J. R., Edwards, P., Fischer, E. V., Farmer, D. K., American Geophysical Union Annual Meeting, "Investigating the impact of VOC composition on the NO_y budget in the northern Colorado Front Range," American Geophysical Union, San Francisco, CA, United States. (December 13, 2016).

Fischer, E. V., Abeleira, A. J., Lindaas, J., Tzompa-Sosa, Z. A., Zaragoza, J., Emerson, E. W., Brey, S. J., Farmer, D. K., Pollack, I. B., Flocke, F., Roscioli, J., Herndon, S., Zhou, Y., Sive, B., 10th Annual Earth System and Space Science Poster Conference at ATOC, "Things I've Learned Lately: Insights into O₃ in the Front Range from New Surface Observations of O₃ and its Precursors," University of Colorado at Boulder, Boulder, Colorado, United States. (December 2, 2016). INVITED

Fischer, E. V., Farmer, D. K., Pollack, I. B., Abeleira, A. J., Lindaas, J., Tzompa Sosa, Z. A., Zaragoza, J., Emerson, E., Flocke, F., Roscioli, J., Herndon, S., American Chemical Society Annual Meeting, "Following emissions from non-traditional oil and gas development through their impact on tropospheric ozone," American Chemical Society, Philadelphia, PA, United States. (August 22, 2016). INVITED

Fischer, E. V., A. Abeleira, E. Emerson, I. Pollack, D. K. Farmer, J. Lindaas, F. Flocke, J. R. Roscioli, and S. C. Herndon., American Meteorological Society Annual Meeting, "Exploring the Influence of Oil and Gas Emissions on Photochemistry in the Northern Colorado Front Range During Summer 2015," American Meteorological Society, Seattle, WA, United States (January 24, 2017).

Lindaas, J., Farmer, D. K., Pollack, I. B., Abeleira, A. J., Zaragoza, J., Flocke, F., Roscioli, R., Herndon, S., Fischer, E. V., International Global Atmospheric Chemistry (IGAC) Project 2016 Science Conference, "Investigating the effects of aged wildfire smoke on photochemistry in the Northern Front Range of Colorado," International Global Atmospheric Chemistry (IGAC) Project, Breckenridge, Colorado, United States. (September 29, 2016).

Lindaas, J., Farmer, D. K., Pollack, I. B., Abeleira, A. J., Zaragoza, J., Flocke, F., Roscioli, R., Herndon, S., Fischer, E. V., American Meteorological Society Annual Meeting, " Aged Wildfire Smoke and Summertime Photochemistry in the Northern Colorado Front Range," American Meteorological Society, Seattle, WA, United States (January 26, 2017).

“Forecasting North Pacific Blocking and Atmospheric River Probabilities: Sensitivity to Model Physics and the MJO”: Progress Report

1. General Information

Project Title: Forecasting North Pacific Blocking and Atmospheric River Probabilities: Sensitivity to Model Physics and the MJO

PI/co-PI names and institutions: PI Elizabeth Barnes (CSU) and Co-PI Eric Maloney (CSU)

Report Year (Progress Report Fiscal Year or Final Report): FY17

Grant #: NA16OAR4310064

2. Main goals of the project, as outlined in the funded proposal

The overarching aim of the proposed work is to quantify the extent to which east Pacific blocking and AR probabilities can be skillfully forecast at lead times of multiple weeks through their dynamical link with the MJO, including an explicit investigation of how AR prediction skill varies with a model’s ability to forecast the MJO. The work can be summarized by four main scientific goals:

- A. Quantification of the predictability and prediction skill of North Pacific blocking and atmospheric river probabilities through knowledge of the MJO.
- B. Assessment of the sensitivity of forecast skill to MJO skill and model setup: model physics, model resolution and forecast lead time.
- C. Deliver a database of extreme events (i.e. atmospheric rivers and blocking) from the reanalysis and hindcast models
- D. Deliver statistical forecast models of extremes (i.e. atmospheric rivers and blocking)

We also have primary goals related to leadership of the MAPP S2S Task Force:

- E. provide scientific leadership to the Task Force (PI Barnes is the Lead of the Task Force) by leading scientific papers, reports and special collections, organizing meetings and meeting sessions, leading teleconferences, facilitating collaboration across the Task Force.
- F. linking to international efforts on advancing S2S prediction

3. Results and accomplishments (*links to goals given in brackets*)

Science Accomplishments/Results

- [A,B,C] successfully hired a PhD student (Kai-Chih Tseng) and postdoctoral

researcher (Cory Baggett) to work on the project

- [C] atmospheric rivers have been detected in the S2S database hindcasts and information for how Task Force members may access this data set are posted on the Task Force wiki
- [A,D,F] a statistical model based on the MJO and QBO has been developed that can skillfully predict atmospheric river activity up to 5 weeks in advance; results are being written up for publication in the Special Issue of npj Climate and Atmospheric Science organized by the International S2S Project
- [A,B] results based on reanalysis and S2S hindcasts show that the combined MJO and QBO influence on atmospheric river activity may provide forecast skill into S2S timescales; an important result being that if the QBO is not considered, the MJO signal appears washed out, however, if the QBO is considered a signal clearly emerges up to 3 weeks in advance; results are being written up for publication [see figure below]

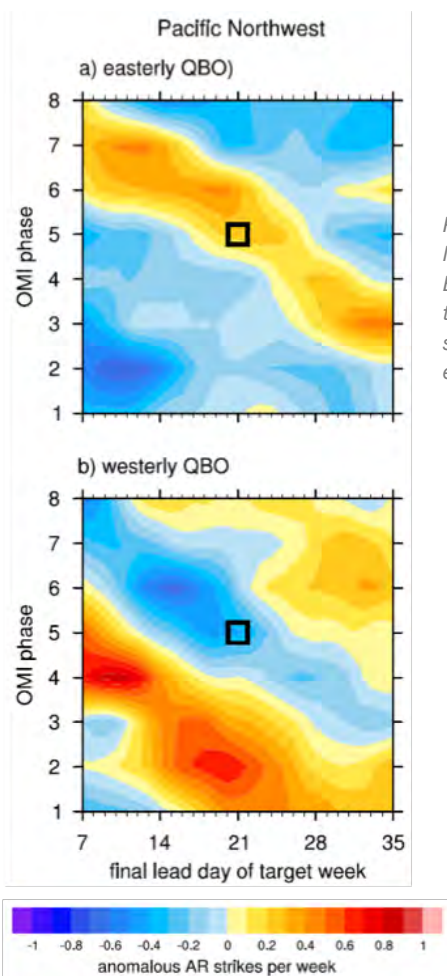

PRELIMINARY RESULT: Anomalous weekly AR activity over the Pacific Northwest in NDJF for (a) easterly and (b) westerly QBO states based on the ERA-Interim reanalysis. The MJO phase is shown on the y-axis and lead day on the x-axis. Both panels show the influence of the propagating MJO, but subsetting by QBO shows that the easterly and westerly phases in general cancel each other. [results by postdoc Cory Baggett]

- [A,B,F] only certain phases of the MJO appear to have robust teleconnections with midlatitudes that lead to North Pacific blocking based on the reanalysis; the ECMWF ensemble hindcasts show similar results – namely, that the ensemble members agree more on midlatitude blocking patterns associated with the MJO in some phases compared to others; results are being written up for publication in the Special Issue of npj Climate and Atmospheric Science organized by the International S2S Project
- [B] The database from phase 5 of the Coupled Model Intercomparison Project (CMIP5) was used to assess the impact of model MJO and basic state quality on MJO teleconnection pattern quality. Even in GCMs assessed to have good MJOs, large biases in the MJO teleconnection patterns are produced due to errors in the zonal extent of the Pacific subtropical jet. These results are featured in a paper in press in J. Climate.

[E] Task Force Leadership Accomplishments/Results

- an internal wiki has been set up (and is being actively maintained by postdoc Cory Baggett) to foster collaboration across the Task Force; the wiki includes information like upcoming meetings of interest to the S2S community, synopses of the different funded groups, and a place to upload data and code for sharing
- PI Barnes and the other Task Force leads have organized and facilitated six Task Force telecons with attendance between 30+ in attendance at each call
- Creation of a two-page summary document of the Task Force's driving questions and a schematic depicting how the different projects connect with each other; this document is expected to be used for both external communication of Task Force efforts but also to inform Task Force members of possible avenues for collaboration.

[E, F] Workshop Organization

- 12/05/2016 Helped organize a one-day NOAA MAPP S2S Kickoff Meeting at Columbia University's Lamont-Doherty Earth Observatory; the event was very successful with participants representing all but one funded project; immediate actions stemming from the workshop have led to further development of the Task Force Wiki and a two-page summary document of the Task Force goals and scientific linkages; representatives from international S2S efforts were also present
- Coordinating an AGU session on S2S Prediction with the broader S2S community: Duane Waliser, Fred Vitart and Arun Kumar

[F] Linking to international efforts

co-PI Maloney is helping co-organize international S2S subprojects related to the MJO and tropical-extratropical teleconnections:

<http://s2sprediction.net/xwiki/bin/view/Main/Interactions+and+teleconnections+between+midlatitudes+and+tropics>,

<http://s2sprediction.net/xwiki/bin/view/Main/MJO>).

[A,B] Conference/Workshop Presentations

- 11/16/2016 Extreme moisture transport in the middle- and high-latitudes with implications for forecasting on S2S timescales, Berkeley Atmospheric Sciences Center, UC-Berkeley, California. [Barnes invited seminar speaker]
- 12/06/2016 Forecasting North Pacific blocking and atmospheric rivers on S2S Timescales, S2S Extremes Workshop, IRI, Columbia University, New York. [invited speaker]
- 12/06/2016 An assessment of the strike probabilities of atmospheric rivers along the west coast of North America as a function of MJO phase in S2S hindcast models, S2S Extremes Workshop, IRI, Columbia University, New York. [poster by postdoc Cory Baggett]
- 01/18/2017 Forecasting North Pacific blocking and atmospheric rivers on S2S Timescales, CW3E All-Hands Workshop, Scripps Institute of Oceanography, UC – San Diego, California.
- 01/26/2017 Modulation of Landfalling Atmospheric River Activity by Northeast Pacific Height Anomalies, 2017 AMS Annual Meeting, Washington. [talk by graduate student Bryan Mundhenk]

4. Highlights of Accomplishments

- The NOAA MAPP S2S Task Force is underway and there appears to be a lot of energy and motivation behind the Task Force activities, including the two-page summary document. The one-day kickoff meeting in December was also a great success.
- The MJO-QBO connection is shown to be important for S2S predictability of midlatitude extreme events, specifically, North Pacific blocking and atmospheric rivers.
- The development of an MJO-QBO-based statistical forecast model of atmospheric river activity along the west coast of North America shows skill out to 5 weeks.

5. Transitions to Applications

N/A

6. Publications from the Project

Three manuscripts will be submitted in the next 2 months as indicated in Section 3 above, in addition to that listed below.

Henderson, S., E. Maloney, and S. Son, 2017: Madden-Julian Oscillation Pacific teleconnections: The impact of the basic state and MJO representation in General Circulation Models. *J. Climate*. doi:10.1175/JCLI-D-16-0789.1, in press.

7. PI Contact Information

Elizabeth A. Barnes
Assistant Professor
Department of Atmospheric Science | Colorado State University
E: eabarnes@atmos.colostate.edu | P: 970-491-8206
Web: <http://barnes.atmos.colostate.edu/>

8. Budget for Coming Year (annual progress reports only)

	Budget Year 1	April-June	Budget Year 2	July 2017-June 2018
Barnes salary & fringe	\$14,950	1.0 months	\$23,100	1.5 months
Maloney salary & fringe	\$8,975	0.5 months	\$9,200	0.5 months
Postdoc salary & fringe	\$16,500	Full time	\$67,700	Full time
Graduate Student salary & fringe	\$10,345	Full time	\$35,800	Full time
Travel	\$4,120		\$7,780	
Supplies	\$670		\$1,000	
Tuition	\$6,240	1 semester	\$12,480	2 semesters
Publications	\$3,120	1 publication	\$3,245	1 publication
Other Direct Costs	\$2,600	Network & computer systems support	\$10,720	network charges & computer systems support
Indirect Costs	\$18,385		\$47,564	30% indirect rate
TOTAL BUDGET	\$85,905	Year 1 remaining as of 3/31 = \$95,043	\$218,589	Year 2 funds = \$209,451
OVERALL TOTAL	\$304,494	Equals remaining budget for Years 1 and 2 combined		

9. Future Work

In the coming year...

- Submit and publish the three papers being written-up in this reporting period
- Continue to organize and lead Task Force telecons; keep the wiki up-to-date
- Investigation into the mechanisms behind the lack of robust MJO teleconnections during some phases compared to others in reanalyses and hindcast models
- Continued investigation into the MJO-QBO-extreme weather linkages and their prediction/predictability

- Organize AGU session (session proposal has been submitted)
- Present results at NOAA Science Days in June
- Postdoc and graduate student will travel to AGU to present their results
- Near the end of Year 2, begin planning and facilitating technical report/comprehensive article with contributions from Task Force members

PROJECT TITLE: Implementation and Testing of Lognormal Humidity and Cloud-related Control Variables for the NCEP GSI Hybrid EnVar Assimilation Scheme

PRINCIPAL INVESTIGATOR(S): Steven J. Fletcher

RESEARCH TEAM: N/A

NOAA TECHNICAL CONTACT: Dr. Daryl Kleist, EMC

NOAA RESEARCH TEAM: Data Assimilation

PROJECT OBJECTIVES:

To implement and test the non-Gaussian data assimilation theory that has been developed at CIRA for moisture and hydrometeor fields in clear sky and cloudy radiance assimilation with the NOAA operational data assimilation system.

This project also has a subaward to the University of Maryland to: 1) assessing the current choice of stochastic physics schemes and related parameters that result in the current behavior of the ensemble spread, 2) explore alternate choices for humidity and cloud ensemble perturbation variables within EnVar, 3) move toward alternate localization strategies for clouds and humidity

PROJECT ACCOMPLISHMENTS:

The award started On September 1 2016 and Dr. Fletcher has been seeking NOAA HPC access, along with the ability to work with an as near to operations version of the GSI system as possible. The HPC access has been granted, and following a telecom with the data assimilation group at EMC, Dr. Fletcher has been granted allocation on the new data assimilation research areas total allocation to run small experiments with the non-Gaussian changes, as well as access to a trunk version of the operational code to relay changes back quicker.

Dr. Fletcher presented the theory of the mixed distribution which will be used at the annual Fall Meeting of the AGU in December 2016 in San Francisco, along with the identified theoretical changes needed to the various components of the GSI, but static and hybrid.

The first year's subaward funds have been sent to the University of Maryland for them to start work, but there has been a change of PI on that end as Dr. Kleist has now returned to NCEP and is the lead from that end. The new UMD PI is Prof. Kayo Ito.

Publications:

Fletcher, S. J. and D. T. Kleist, 2016: Implementing of lognormal humidity and cloud-related control variables for the NCEP GSI hybrid EnVAR Assimilation scheme. Poster at the Annual Fall Meeting of the American Geophysical Society, December 12 – 16, 2016, San Francisco, CA.

NOAA FY 15 Joint Hurricane Testbed (JHT) program

Project Title: Improvement and Implementation of the Probability-based Microwave Ring Rapid Intensification Index for NHC/JTWC Forecast Basins

PI: Haiyan Jiang, Associate Professor, Ph: 305-348-2984, haiyan.jiang@fiu.edu

Co-PI: Kate Musgrave, Research Scientist, Ph: 970-491-8382, kate.musgrave@colostate.edu

Submission Date: March 30, 2017

Recipient Organization: Cooperative Institute for Research in the Atmosphere,
Colorado State University,
1375 Campus Delivery, Fort Collins, CO 80523-1375

Project/Grant Period: 09/01/2015 – 08/31/2017

Reporting Period: 09/01/2016-02/28/2017

Report Term or Frequency: semi-annual

Final Annual Report? No

NOAA AWARD NUMBER: NA15OAR4590200

1. ACCOMPLISHMENTS

The major proposed goal was to improve the probability-based tropical cyclone (TC) rapid intensification (RI) forecast method under our JHT FY-13 project by adding two additional 37 GHz predictors on top of the original the 37 GHz ring and three 85 GHz predictors. The final product is called the **probability-based microwave ring RI index (hereafter PMWRing RII)**. It was proposed to implement the PMWRing RII in the NHC and JTWC forecast basins, including Atlantic (ATL), Eastern & Central North Pacific (EPA), North Western Pacific (NWP), North Indian Ocean (NIO), and Southern Hemisphere (SH) basins. Under this major goal, there were five tasks proposed. Please see the table below for the planned vs. actuals for these tasks.

Tasks	Planned	Actuals
Task 1	<i>Collecting historical microwave data from AMSR-E, SSM/I, and SSMIS and calibrating their T_B's to be compatible with TMI T_B's</i>	Completed, although we made some changes from the original plan. We chose to we choose to treat each sensor differently to avoid the sensor inter-calibration and different sensor resolution issue. The sample size is large enough for each sensor.
Task 2	<i>(CIRA) Generating the SHIPS RI developmental dataset for JHT basins</i>	Completed for North Hemisphere basins (ATL, EPA, NWP & NIO); need to complete the SH basin during year-2 as planned (please see section 6 for details).
Task 3	<i>Development of the PMWRing RII for each basin</i>	Completed for North Hemisphere basins (ATL, EPA, NWP & NIO); need to complete the SH basin during year-2 as planned (please see section 6 for details).
Task 4	<i>Real-time testing at NHC and JTWC</i>	Real-time testing ongoing for the 2016 season for ATL, EPA, NWP & NIO basins; need to complete the SH basin during year-2 as planned (please see section 6 for details).
Task 5	<i>Evaluate the real-time testing results and refine the index based on lessons learned</i>	We have finished evaluation of 2016's real-time results. Problems were identified and the algorithm was refined based on the solution of the problems, as we presented at the IHC.

There were 6 milestones proposed for year-1 and 7 milestones for year-2. All 6 milestones for year-1 have been completed as planned. Please see the table below.

Milestones for year-1	Planned	Actuals
Milestone 1 (Sep 2015)	FIU: Generate the developmental microwave data including TMI, AMSR-E, SSM/I, and SSMIS data for ATL, EPA, NWP and NIO basins; CIRA: Generate the developmental SHIPS RII dataset for NWP and NIO basins	Completed as planned
Milestone 2	FIU: develop RI thresholds for SHIPS	Completed as planned

(Nov 2015)	RII and microwave predictors for ATL, EPA, NWP and NIO basins	
Milestone 3 (Jan 2016)	Begin development of the PMWRing RII for ATL, EPA, and NWP/NIO basins	Completed as planned
Milestone 4 (Mar 2016)	Present preliminary results at the IHC; Mid-year report	Completed as planned
Milestone 5 (May 2016)	Complete the algorithm development and implement the real-time testing code for 2016 Hurricane/Typhoon season in ATL, EPA, NWP, and NIO basins	Completed as planned
Milestone 6 (June 2016- Nov 2016)	Real-time testing in ATL, EPA, NWP, and NIO basins	Completed as planned
Milestones for year-2	Planned	Actuals
Milestone 1 (Sep 2016)	FIU: Generate the developmental microwave data including TMI, AMSR-E, SSM/I, and SSMIS data for SH; CIRA: Generate the developmental SHIPS RII dataset for SH	FIU portion completed as planned; CIRA provided a preliminary SHIPS RII dataset on Feb. 2017, but the final version is on the way
Milestone 2 (Nov 2016)	FIU: develop RI thresholds for SHIPS RII and microwave predictors for SH	Preliminary work is done using CIRA's preliminary SHIPS RII dataset, but the results will need to be revised after getting the final version of SHIPS RII.
Milestone 3 (Dec 2016)	Complete development of the PMWRing RII and implement the real-time testing code for 2017 TC season for SH;	Preliminary real-time testing at SH has started, but the code will be revised after getting the final version of SHIPS RII.
Milestone 4 (Jan 2017)	Evaluate the year-1 testing results for ATL, EPA, NWP, and NIO basins	Completed as planned
Milestone 5 (Mar 2017)	Adjust the index based on real-time testing results; Present preliminary results at the IHC	Completed as planned
Milestone 6 (Jun 2017)	Complete the algorithm refinement and implement the real-time testing code for 2017 Hurricane/Typhoon season in all northern hemisphere basins	Not started yet. Will do it as planned.
Milestone 7 (Jul-Aug 2017)	Year 2 final report	Not started yet. Will do it as planned.

This project has provided training and professional development opportunities for two post-doctoral research scientists (Jon Zawislak and Cheng Tao) and two graduate students (Yongxian Pei and Margie

Kieper). The results of the real-time RI index have been disseminated to NHC & JTWC points of contact through emails and a website at <http://tcpf.fiu.edu/JHT/> during 2016 & 2017 hurricane/Typhoon season. Publications and conference presentations have also been made (please see the following section).

2. PRODUCTS

There were two products/deliverables proposed. See the table below for the planned vs. actuals:

products/deliverables	Planned	Actuals
Product 1	Code (in IDL) that will produce the PMWRing RI index	Not completely finished yet
Product 2	A detailed document of the guidance for running the code, and predicting RI using the 37 GHz index with the SHIPS RI index	The document for predicting RI using the PMWRing RI index with the SHIPS RI index has been completed. The document of the guidance for running the code will be done at the ending period of this project by closely collaborating with NHC/JTWC folks.
Product 3	Not planned	1)A product of the FIU PMWRing RI Index 2) A real-time RI forecast website: http://tcpf.fiu.edu/JHT/ ; 3) Publications (please see the list below)

Publications and presentations from this reporting period:

- Jiang, H., J. P. Zagrodnik, C. Tao, and E. J. Zipser 2017: What type of precipitation is represented by different color regions in the NRL 37 GHz color tropical cyclone product? *J. Geophys. Res.*, under review.
- Tao, C., H. Jiang, and J. Zawislak 2016: The Relative Importance of Stratiform and Convective Rainfall in Rapidly Intensifying Tropical Cyclones, *Mon. Wea. Rev.*, **145**, 795-809.
- Rogers, R. F., J. Zhang, Zawislak, J., H. Jiang, G. R. Alvey III, E. J. Zipser, and S. Stevenson, 2016: Observations of the structure and evolution of Hurricane Edouard (2014) during intensity change. Part II: Kinematic structure and the distribution of deep convection. *Mon. Wea. Rev.*, **144**, 3355–3376.
- Zawislak, J., H. Jiang, G. R. Alvey III, E. J. Zipser, R. F. Rogers, J. Zhang, and S. Stevenson, 2016: Observations of the structure and evolution of Hurricane Edouard (2014) during intensity change. Part I: Relationship between the thermodynamic structure and precipitation. *Mon. Wea. Rev.*, **144**, 3333–3354.
- Jiang, H., B. You, and C. Tao 2017: Estimation of Tropical Cyclone Intensity Using Satellite Passive Microwave Observations. *71st Interdepartmental Hurricane Conference/2017 Tropical Cyclone Research Forum*, Mar 14-16, 2017.
- Jiang, H., J. Zawislak, Y. Pei, C. Tao, K. Musgrave, and G. Chirokova 2017: JHT Project 3: “Improvement and Implementation of the Probability-based Microwave Ring Rapid Intensification Index for NHC/JTWC Forecast Basins” *71st Interdepartmental Hurricane Conference/2017 Tropical Cyclone Research Forum*, Mar 14-16, 2017.

3. PARTICIPANTS & OTHER COLLABORATING ORGANIZATIONS

Individuals have worked on this project include Haiyan Jiang (PI), Jon Zawislak (research scientist), Cheng Tao (Postdoc Research Associate), Yongxian Pei (PhD student), and Margie Kieper (PhD student). There have been no changes in the PI and senior/key personnel since the last reporting period. FIU is partnering with CSU CIRA on this project. NHC points of contact (Chris Landsea, John Cangialosi, and Stacy Stewart) and JTWC point of contact (Brian DeCicco) have been involved.

4. IMPACT

According to the evaluation results of 2016 real-time testing & post-season re-run, our algorithm was able to provide a higher probability of detection (POD) in AL, EP, and WP basins and a lower false alarm ratio (FAR) in the WP basin than the SHIPS RII. The impact of this project on the prediction of rapid intensification in SH will be assessed later in year 2 as part of the evaluation of real-time testing results. The education and professional training impact is addressed in Section 1. None of the FIU portion of the budget has been spent in foreign countries.

5. CHANGES/PROBLEMS

No significant changes have occurred in the planned/completed work of the project.

6. SPECIAL REPORTING REQUIREMENTS

a. The project's Readiness Level:

Current: RL 6-7

At the start of project: RL 3

b. Transition to operations activities and summary of testbed-related collaborations, activities, and outcomes:

The quasi-real-time testing of the PMWRing RI index (RII) for ATL and EPA basins for NHC and NWP & NIO basins for JTWC has started in June 2016 and is still ongoing. The real-time forecasts are provided to NHC/JTWC points of contact through emails (only when a positive RI forecast is made) and our JHT project webpage (<http://tcpf.fiu.edu/JHT/>).

c. Has the project been approved for testbed testing yet? What was transitioned to NOAA?

Yes, the project has been approved for testbed testing. But it wasn't transitioned to NOAA because NHC and/or JTWC haven't decided to either transition it or not. The final decision will be made after this project is completed.

d. Test plans for the 2017 Hurricane/Typhoon season:

- I. What **concepts/techniques** will be tested? What is the scope of testing (what will be tested, what won't be tested)?

The PMWRing RII will be tested for RI forecasts in AL, EP/CP, WP/IO, & SH basins. We'll test the code for reading different microwave satellite data. We'll also test the strategy of using SHIPS RII as a criterion in generating our probability output.

- II. **How** will they be tested? What **tasks** (processes and procedures) and activities will be performed, what preparatory work has to happen to make it ready for testing, and what will occur during the experimental testing?

We'll run the real-time code separately for each basin and each satellite sensor. All the preparatory work is complete except that "Preliminary real-time testing at SH has started, but the code will be revised after getting the final version of SHIPS RII", as mentioned in section 1 above. The real-time forecasts are provided to NHC/JTWC points of contact through emails (only when a positive RI forecast is made) and our JHT project webpage (<http://tcpf.fiu.edu/JHT/>).

- III. **When** will it be tested? What are **schedules and milestones** for all tasks described in section II that need to occur leading up to testing, during testing, and after testing?

For AL, EP/CP, and WP/IO basins, the 2017 testing will start on June 1, 2017. For the SH, the formal testing will be starting on Apr. 1, 2017. We plan to apply for a 1-yr no-cost extension of this funding. That way, we'll continue the real-time testing till the 2017 hurricane/Typhoon season ends at around Nov. 1, 2017. For the schedules/milestones, please see the table in section 1.

- IV. **Where** will it be tested? Will it be done at the PI location or a NOAA location?

The testing code will run at FIU, the PI's location.

- V. Who are the key **stakeholders** involved in testing (PIs, testbed support staff, testbed manager, forecasters, etc.)? Briefly what are their **roles and responsibilities**?

The PI and her research team will be responsible for maintaining the testing code & running; NHC Points of Contact Stacy Stewart, John Cangialosi, and Chris Landsea and JTWC Point of Contact Brian deCicco will help evaluate the real-time results.

- VI. What **testing resources** will be needed from each participant (hardware, software, data flow, internet connectivity, office space, video teleconferencing, etc.), and who will provide them?

FIU will provide all the hardware & software for testing.

- VII. What are the **test goals, performance measures, and success criteria** that will need to be achieved at the end of testing to measure and demonstrate success and to advance Readiness Levels?

The **goal** is to test the code reliability and evaluate the performance of the algorithm. The **performance measures** are the Brier skill scores (BSSs), which should show the algorithm is at least skillful (better than climatology), and ideally better than the SHIPS RII. The **success criteria** are 1) the algorithm can run smoothly in a quasi-operational environment; 2) the performance measures are met.

- VIII. How will testing **results** be documented? Describe what information will be included in the **test results final report**.

The test results will be presented in IHC 2018. They will also be written in our final report, including the statistics of the algorithm performance for 2017 hurricane/typhoon season, i.e., POD, FAR, and BSS.

7. BUDGETARY INFORMATION

No significant changes to the budget have occurred for the FIU portion of this project.

8. PROJECT OUTCOMES

The milestones of this project and the progress towards them are discussed in Section 1, with the deliverables discussed in Section 2. The outcome of this award will be the implementation of the PMWRing RII if NHC and/or JTWC decide to transition the product, which will be decided after the project is completed (as discussed in Section 6). An additional outcome of this project is the list of products contained in Section 2.

Submitted to: OAR Office of Weather and Air Quality (OWAQ)

Federal Grant Number: NA15OAR4590201

Project Title: Improvement to the Tropical Cyclone Genesis Index (TCGI)

Principle Investigator: Jason P. Dunion, Meteorologist; University of Miami/CIMAS – NOAA/HRD; jason.dunion@noaa.gov; (c) 305-720-3060

Co-Principle Investigator: Andrea Schumacher, Research Associate; CIRA/Colorado State University; andrea.schumacher@colostate.edu; 970-491-8057

Submission Date: September 30, 2016

Recipient Organization: CIRA/Colorado State Univ., Campus Delivery 1375, Fort Collins, CO, 80523-1375

Project/Grant Period: 09/01/2015 - 08/31/2017

Reporting Period Start/End Date: 03/01/2016 - 08/31/2016

Report Term or Frequency: Semi-annual

Reporting Timeline: Year-1 annual report of a 2 year Project

1. ACCOMPLISHMENTS

The main goal of this project is to implement improvements to the Tropical Cyclone (TC) Genesis Index (TCGI) that was transitioned to operations at the NOAA National Hurricane Center (NHC) in October 2014. TCGI is a disturbance-following scheme designed to provide forecasters with an objective tool for identifying the 0-48hr and 0-120hr probability of TC genesis in the North Atlantic basin. Progress made under this current funded project includes expanding the TCGI North Atlantic database to include the years 2001-2014, developing a new 2001-2014 Pacific (eastern north Pacific (EPAC) and central North Pacific (CPAC)) TCGI database, identifying new predictors to test in both the Atlantic and Pacific versions of TCGI, deriving an eastern/central Pacific basin TCGI utilizing predictors that were employed in the previously developed Atlantic basin version and developing an ECMWF-based Atlantic TCGI using predictors and predictor weights that were developed for the GFS version of TCGI. The following tasks were conducted and/or completed during this reporting period:

- i. *Present year-1 results at the 70th Interdepartmental Hurricane Conference (March 2016)*
 - PI Dunion presented a project update at the IHC in Miami, FL 14-16 March 2016
 - Dunion, J.P., J. Kaplan, A. Schumacher, J. Cossuth, P.A. Leighton, and K. Musgrave, 2016: Improvement to the Tropical Cyclone Genesis Index (TCGI).

Preprints, 70th Interdep. Hurr. Conf., Miami, FL. NOAA OFCM (Available online at http://www.ofcm.gov/homepage/text/spc_proj/ihc.html.)

- ii. *Begin development of an ECMWF-based Atlantic TCGI using predictors and predictor weights that were developed for the GFS version of TCGI (April 2016)*
 - ERA-Interim data has been collected and is currently being formatted for use in development of ECMWF-based Atlantic TCGI.
 - This project deliverable is nearing completion and is anticipated to be completed by December 2016 (~75% complete).
- iii. *Develop and test graphical TCGI products with real-time cases (August-October 2016)*
 - Based on feedback from the NOAA NHC points of contact on this project, development of a graphical version of TCGI has been eliminated as a funded deliverable for this current project.
- iv. *Begin sensitivity testing for optimal combinations of Atlantic and Pacific TCGI predictors (GFS version); (June-November 2016)*
 - New TCGI predictors have been added to the 2001-2014 Atlantic and East Pacific datasets. Predictors from these new datasets include WWLLN lightning and Tropical Overshooting Tops (only available in the Atlantic). New predictors calculated from the GFS analyses include (1) relative humidity calculated at 850-600 hPa and at 1000-925 hPa, (2) moisture convergence at 850 hPa, (3) vertical wind shear magnitude and direction for the 850-500 hPa layer, (4) generalized vertical wind shear from 1000-100 hPa, and (5) vorticity x divergence at 850 hPa.
 - All area-averaged predictors were generated using the original TCGI 0-500 km radius search radius as well as a new 0-200 km search radius.
 - All of the FORTRAN code that is used to process the developmental genesis datasets and subsequently derive the TCGI was modified to make it possible to assess the significance of the eight recently developed TCGI predictors as well as to evaluate the impact of varying the averaging radius of each of the GFS-based environmental variables from 200-500 km.
 - Sensitivity tests were conducted to assess the significance of the eight newly developed TCGI predictors as well as to evaluate the impact of using the environmental variables that were averaged over the smaller 200 km versus the 500 km radius that is currently employed to evaluate the GFS environmental variables in the current real-time version of the TCGI for both the Atlantic and eastern and central Pacific basins. Fig. 1 shows the impact of averaging the GFS-based environmental variables that are employed in the current real-time version of the TCGI averaged over an annulus of 200-km versus 500-km radius for a homogeneous set of cases from the 2001-2014 developmental Atlantic and central/eastern Pacific basin samples. It can be seen that employing the variables that had been averaged over the smaller 200-km averaging radius results in a substantial increase in the Brier Skill Score in both basins for both the 0-48-h and 0-120-h versions of the TCGI particularly at the 0-48-h lead time.
 - This project deliverable is nearing completion and is anticipated to be completed by December 2016 (~80% complete).

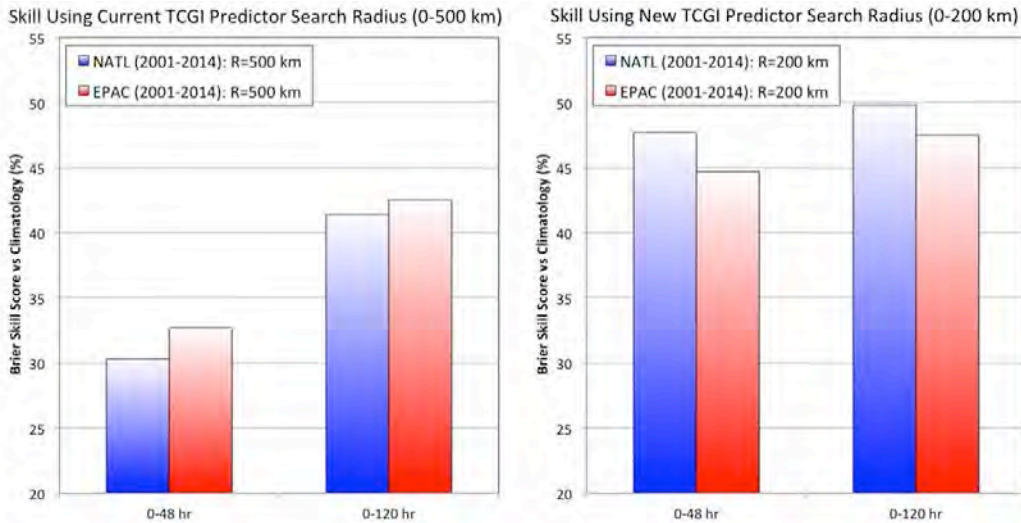

Fig. 1: Brier Skill Score (relatively to climatology) for the newly expanded 2001-2014 Atlantic (blue shading) and the newly developed 2001-2014 eastern/central Pacific (red shading) TCGI invest databases. The skill for 0-48 hr and 0-120 hr was determined using the six predictors that are currently used in the operational TCGI using the (left) current 0-500 km predictor search radii and (right) the newly developed/tested 0-200 km predictor search radius.

The proposed deliverables listed above (i-iv) are either completed or on track for completion according to the proposed timeline. This project is in the developmental year-1 phase and no training or professional development efforts apply to this reporting period. The code for producing the deliverable of this project (an upgraded TCGI for the North Atlantic and new version of TCGI for the eastern and central North Pacific) is on track to be turned over to NOAA in August 2017 at which time it can be disseminated to communities of interest. Current plans include completing deliverables ii and iv and beginning to work on the next set of deliverables:

- March 2017 Present year-2 results at IHC
- April 2017 Based on POC and IHC feedback, refine TCGI graphical products.
- June-Aug 2017 Perform real-time tests of TCGI graphical products in-house at NHC or online at: http://rammb.cira.colostate.edu/realtime_data/nhc/tcgi/
- May-Aug 2017 Perform real-time tests of 0-48 and 0-120 h Atlantic and Pacific TCGI (GFS version) on NESDIS computers at CIRA with output being made available online at: http://rammb.cira.colostate.edu/realtime_data/nhc/tcgi/
Perform real-time tests of 0-48 and 0-120 h Atlantic and Pacific TCGI (ECMWF version) at NHC (requires computing and IT support from NHC)
- May-Aug 2017 Finish development/evaluation of prototype ECMWF-based TCGI for Atlantic

Aug 2017 Final code for running both the Atlantic and Pacific TCGI on operational NCEP computers will be provided to NHC/NCEP IT personnel if the project is accepted for operational transition.

2. PRODUCTS

Efforts related to this project's current reporting period have produced the following:

- a. Conference Papers & Presentations
 - Dunion, J.P., J. Kaplan, A.B. Schumacher, J. Cossuth, K.D. Musgrave, and P. Leighton, 2016: Improvements to the Tropical Cyclone Genesis Index (TCGI). *70th Interdepartmental Hurricane Conference - Tropical Cyclone Operations and Research Forum*, Miami, FL, Office of Fed. Coord. For Meteor. Services and Supporting Research, NOAA.
http://www.ofcm.gov/homepage/text/spc_proj/ihc.html
 - Dunion, J.P., J. Kaplan, A. B. Schumacher, J. Cossuth, K.D. Musgrave, and P. Leighton, 2016: The Tropical Cyclone Genesis Index (TCGI), *32nd Amer. Meteor. Soc. Conf. on Hurricanes and Tropical Meteor.*, San Juan, Puerto Rico.
<https://ams.confex.com/ams/32Hurr/webprogram/start.html>
- b. Real-Time TCGI Website (hosted by the Colorado State University-CIRA):
 - http://rammb.cira.colostate.edu/projects/tc_genesis/
- c. 2001-2014 Tropical Disturbance Database for the Atlantic and Pacific
 - An updated tropical disturbance database for the North Atlantic spanning the years 2001-2014 has been developed under this project.
 - A new tropical disturbance database for the central and eastern North Pacific spanning the years 2001-2014 has been developed under this project.
- d. Software for Analyzing Tropical Cyclone Genesis in Atlantic and Pacific
 - New software has been developed to analyze important tropical cyclone inner core and environmental predictors for forecasting tropical cyclone genesis.
 - Algorithms have been developed to analyze the 2001-2014 Atlantic and Pacific databases and will be incorporated into the upgraded (new) TCGI for the Atlantic (Pacific).

3. PARTICIPANTS & OTHER COLLABORATING ORGANIZATIONS

The following team members have contributed to this project (no changes to senior/key project personnel has occurred since the last reporting period and only the personnel and institutions listed below have been involved in the project during this reporting period):

Co-PIs

John Kaplan, NOAA/AOML/Hurricane Research Division, john.kaplan@noaa.gov
Andrea Schumacher, Colorado State University/CIRA, schumacher@cira.colostate.edu
Joshua Cossuth, Naval Research Laboratory-Monterey, Joshua.Cossuth.ctr@nrlmry.navy.mil

Co-Is

Paul Leighton, NOAA/AOML/Hurricane Research Division, paul.leighton@noaa.gov

Kate Musgrave, Colorado State University/CIRA, Kate.Musgrave@colostate.edu

The following lists the tasks outlined in Sec. 1 and the project team members who contributed to those efforts:

- Task i: PI Dunion
- Task ii: Co-PI Schumacher and Co-I Musgrave
- Task iv: Co-PI Schumacher, Co-I Musgrave, Co-PI Kaplan, Co-Leighton, and PI Dunion

4. IMPACT

This project is in the developmental year-1 phase the important NOAA-identified impacts for this reporting period do not apply. None of this project's funds have been budget has been spent in a foreign country.

5. CHANGES/PROBLEMS

Project deliverable iii (*Develop and test graphical TCGI products with real-time cases*) has been eliminated from the project deliverables at the request of NOAA NHC. No other changes other the methodology and approach for this project have been made for this reporting period. Project timelines, budget are on track and future changes are not anticipated.

6. SPECIAL REPORTING REQUIREMENTS

The readiness level for this reporting period is estimated to be a RL4 to RL5.

7. BUDGETARY INFORMATION

This project's budget is on track and no changes are anticipated.

8. PROJECT OUTCOMES

The main deliverable of this project is to implement improvements to the Tropical Cyclone (TC) Genesis Index (TCGI) that was transitioned to operations at the NOAA National Hurricane Center (NHC) in October 2014. The outcome of this effort will be to turn over the operational code for running the upgraded TCGI to NOAA in August 2017. Performance measures that are defined in this project are being achieved and are on track.

NOAA/JHT

Federal Grant Number Assigned by Agency: NA15OAR4590204

Title: Improvements to Operational Statistical Tropical Cyclone Intensity Forecast Models

Galina Chirokova, Research Scientist
Galina.Chirokova@colostate.edu
Andrea Schumacher, Research Associate
Andrea.Schumacher@colostate.edu
970-491-8448

Laura Leinen
Recipient Administrator
Laura.Leinen@colostate.edu
970-491-8525

Submission Date: 03/30/2017

Colorado State University
200 W. Lake Street
Fort Collins, CO 80521-4593

Award Period: 9/1/15-8/31/17

Reporting Period End Date: 2/28/17

Report Term or Frequency: semi-annual

Final Annual Report? No

1. ACCOMPLISHMENTS

Summary of the project accomplishments for the 3 main project tasks:

- 1) **Replace in SHIPS and LGEM weekly 1° resolution SSTs with daily 0.25° resolution SSTs.** These changes were designed to improve forecast performance and set the stage for including upper-ocean data to explicitly account for SST cooling. The software for pre-processing daily Reynolds SST data was developed and modifications to the model to add the option to use either weekly or daily SST were completed. A new module was added to SHIPS/LGEM to handle the selection of SST and ocean heat content (OHC) data and that module has been implemented in the 2016 version of SHIPS on WCOSS. All changes for this task were incorporated into the 2016 version of SHIPS and retrospective and parallel runs with daily SST and verification have been

completed. The code to generate global and regional daily SST data, the modified SHIPS/LGEM, and verification results have been provided to NHC for evaluation.

- 2) **Add to SHIPS/LGEM a physical mechanism to account for storm-induced SST cooling.** Lin et al. (2013) and Price (2009) have demonstrated that the use of tropical cyclone- (TC) cooled SST instead of SST to calculate the storm maximum potential intensity (MPI) produces a more realistic upper intensity bound estimate and that the ocean temperature vertically-averaged from the surface to the depth of TC-induced mixing is a more robust metric of the SST cooling effect than the OHC. The algorithm for estimating the depth-averaged temperature (DAVT) assuming constant and variable mixing depth from the OHC data available in real-time has been developed and incorporated into the SHIPS and LGEM processing scripts. The option to use either SST or DAVT has been added to both SHIPS and LGEM. The final version of the algorithm to use DAVT with variable mixing depth and final regression coefficient will be derived using the 2017 version of SHIPS/LGEM to allow direct comparison of the experimental version with the operational version during 2017 Atlantic and East Pacific hurricane seasons.
- 3) **Add forecasts of TC structure (wind radii and MSLP) to SHIPS/LGEM.** A statistical-dynamical method to predict tropical cyclone wind structure (Decay SHIPS Wind Radii, DSWR) in terms of wind radii has been developed and has been running in real-time since August 2016. The basis for TC size variations is developed from an infrared satellite-based record of TC size (Knaff et al. 2014), which is homogeneously calculated from a 1996-2012 sample. The change in TC size is predicted using a statistical-dynamical approach where predictors are based on environmental diagnostics derived from global model forecasts and observed storm conditions. Once the TC size has been predicted, the forecast intensity and track are used along with a parametric wind model to estimate the resulting wind radii following Knaff et al. (2017). The DSWR code and verification results have been provided to NHC and JTWC.

What were the major proposed **goals, objectives, and tasks** of this project, and what was accomplished this period under each task? (a table of planned vs. actuals is recommended as a function of each task identified in the funded proposal)

Goals, Objectives, Tasks	Planned: Sep 2016 – Aug 2017	Actual: Sep 2016 – Aug 2017
Modify SHIPS and LGEM to use 0.25° daily Reynolds SST	Evaluate parallel runs from 2016 and make necessary adjustments to SHIPS.	The evaluation of the parallel runs has been completed and the results were provided to NHC and presented at the Interdepartmental Hurricane Conference (IHC). Minor modifications were made to the SST database and SHIPS code based on the results of the parallel runs.
Modify SHIPS and LGEM models to use DAVT	Modify SHIPS/LGEM code to work with DAVT assuming constant and variable mixing depth	The SHIPS/LGEM code was modified to work with DAVT estimated assuming either constant or variable mixing depth.
Add forecasts of TC structure (wind radii and MSLP) to SHIPS/LGEM	Evaluate parallel runs from 2016 and make necessary adjustments to DSWR	The evaluation of the parallel runs was completed and the results were provided to NHC, presented at IHC, and published. In addition, test runs with including DSWR into the RVCN consensus model were completed.

Are the proposed project tasks **on schedule**? What is the cumulative percent toward completion of each task and the due dates? (table recommended)

Task	Cumulative percent towards completion and due dates	Due Date	On schedule (yes/no)
Modify SHIPS and LGEM models to use 0.25° daily Reynolds SST	100%	Feb 2017	Yes
Modify SHIPS and LGEM models to use DAVT	50%	Feb 2017	Yes
Add forecasts of TC structure (wind radii and MSLP) to SHIPS/LGEM	100%	Feb 2017	Yes

What were the major completed **milestones** this period, and how do they compare to your proposed milestones? (planned vs. actuals table recommended)

Milestone	Completed vs proposed
Begin parallel runs during 2016 season and monitor results during the season	Completed as proposed
Modify SHIPS to include DAVT based on the variable mixing depth	Completed as proposed
Extend SHIPS modifications to the global version	Completed as proposed
Evaluate parallel runs from 2016 season and make any necessary adjustments to the modified SHIPS	Completed as proposed

Detailed description of the work completed for each milestone since the last report is presented below.

Milestone: Begin parallel runs during 2016 season and monitor results during the season. Parallel runs of SHIPS/LGEM with daily SST and DAVT assuming constant mixing depth for the Atlantic and East and Central Pacific basins, as well as parallel runs of DSWR for the Atlantic and East and Central Pacific basins have been conducted at CIRA and evaluated. The evaluation results have been provided to NHC. The results of the parallel runs with DSST and DSWR are discussed below. The runs with DAVT with constant mixing depth revealed a number of issues with the climatology and the use of MPI derived for SST in the Atlantic basin. To address these issues, the new climatology that includes the climatology of the ocean mixed layer has been developed, and the new empirical MPI have been derived for the DAVT with constant mixing depth. In addition, the parallel runs of DSWR for West Pacific, Indian Ocean, and Southern hemisphere have been completed and evaluated, and the results were provided to JTWC.

Milestone: Modify SHIPS to include DAVT based on the variable mixing depth. The 2016 version of SHIPS and LGEM has been modified to use RSST, DSST, and/or DAVT with either constant or variable mixing depth. The updated code is written in a way that allows the user to easily select and use different "SST" variable for different parts of the code. That is necessary since SHIPS includes several modules, such as different versions of the Rapid Intensification Index (RII) that have not been trained to use daily SST or DAVT. The DAVT assuming variable mixing depth has been included in SHIPS/LGEM by using the "ocean age" (OA) variable. The OA is a measure of the amount of time that the storm area within $R = 60$ nmi has been over the same patch of the ocean. The mixing depth as a function of storm translational speed (captured by OA) and latitude is estimated from

$$\text{Mixing Depth} = a + b * \left(\frac{t}{T_{\text{ref}}} \right) + c * \left(\frac{t}{T} \right)^2, \quad (1)$$

where t is the ocean age, T is the inertial period ($T = 2\pi/f$, where f is the Coriolis parameter), and T_{ref} is a reference inertial period evaluated at a fixed latitude (30° N). The form of this equation is based on the idealized numerical simulations of Yablonsky and Ginis (2009) with a coupled hurricane model. The linear term in (1) represents mixing processes and the quadratic term represents upwelling. The upwelling time scale depends on the inertial period, so the ocean age is scaled by that. The mixing does not depend explicitly on the inertial period, so the ocean age in the linear term is scaled by a constant reference inertial period. The final coefficients will be determined by optimizing the 2017 version of the SHIPS model.

Milestone: Extend SHIPS modifications to the global version. All modifications for SHIPS and LGEM code, as well as DSWR model, are global, and can be used in all basins. The database of the global DSST and subsurface ocean data has been created, and the 2017 developmental database for all basins including Atlantic, East and Central Pacific, West Pacific, Indian Ocean and Southern Hemisphere has been updated to include DSST and ocean subsurface data that are used to calculate DAVT assuming constant or variable mixing depth. The final regression coefficients for all basins for DSST and DAVT will be derived for the 2017 version of the models which will allow for direct comparison of the experimental version with the operational version based on the parallel runs during 2017 hurricane season.

Milestone: Evaluate parallel runs from 2016 season and make any necessary adjustments to the modified SHIPS.

1) Parallel runs of SHIPS/LGEM with DSST have been conducted during September – November 2016, and the results have been made available to NHC via an ftp site, ftp://rammftp.cira.colostate.edu/chirokova/JHT_2015_2017/rt_demo/, and evaluated. Figure 1 shows the MAE and biases for the 2016 season with DSST. Overall, for the 2016 the use of DSST instead of RSST resulted in slightly improved forecasts for Atlantic for LGEM for $t = 0$ to $t = 60$ hours. SHIPS forecasts for

the Atlantic were very similar to the operational version, and the East Pacific forecasts were a little worse than the operational version with RSST. The LGEM forecast for East Pacific was slightly improved for 0 – 48 hours, and slightly worse for $t > 60$ hours. That is the expected result. The addition of DSST was a first step needed to include the DAVT. Use of DSST can sometimes significantly change SHIPS and LGEM forecasts, especially in the cases when SSTs are rapidly changing, such as in the beginning of the season, or when the storm crosses the cold wake of the previous storm. The forecasts for the individual storms for the Atlantic and East Pacific basins for 2016 season were analyzed, and it was confirmed that sometimes the addition of DSST can result in a noticeable forecast change, but not necessary an improvement.

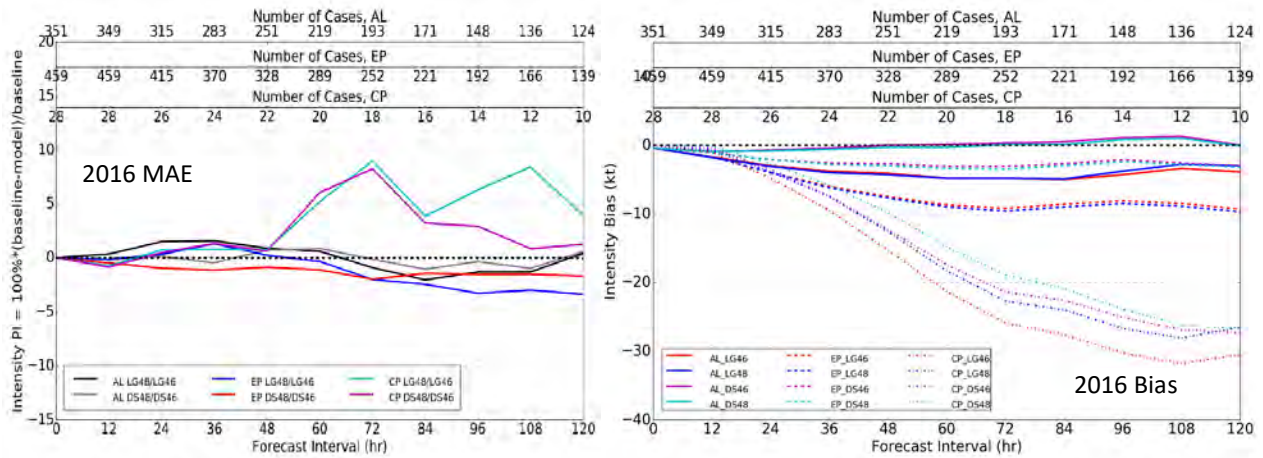

Figure 1. Left: SHIPS/LGEM independent verification for 2016 with daily SST for the 2016 version of the model, with DSST coefficients. Percent improvement relative to the baseline version using weekly SST for the Atlantic (black – LGEM, grey - SHIPS) and East (blue - LGEM; red - SHIPS) and Central Pacific (magenta - LGEM, cyan - SHIPS). Right: intensity bias for the runs shown on the Left. Solid lines show: red – LGEM run for the Atlantic with RSST, blue – LGEM run for the Atlantic with DSST, magenta – SHIPS run for the Atlantic with RSST, cyan - SHIPS run for the Atlantic with DSST. Dashed lines show biases for the corresponding runs for the East Pacific, and dotted line – for the Central Pacific.

The retrospective verification of SHIPS/LGEM with DSST has been reprocessed for the years 2010-2016 to exclude earlier years that are significantly affected by the errors in the track forecasts. Figure 2 shows the verification for DSST runs for the Atlantic, East and Central Pacific basins for the years 2010 – 2016, using model coefficients derived for weekly SST. These results suggest that overall, both SHIPS and LGEM forecasts would benefit from the use of DSST. Specifically, the LGEM forecasts for the East Pacific improve by up to 3% for 96 hr forecast, and the SHIPS forecasts for both Atlantic and East Pacific improve as well, approximately by 1% at $t = 96$ hours. LGEM forecasts for the Atlantic are similar to the operational version for $t = 0 - 72$ hours, and get slightly worse than the operational version at larger forecast times. These results were provided to NHC for evaluation and some of these results were presented at the IHC.

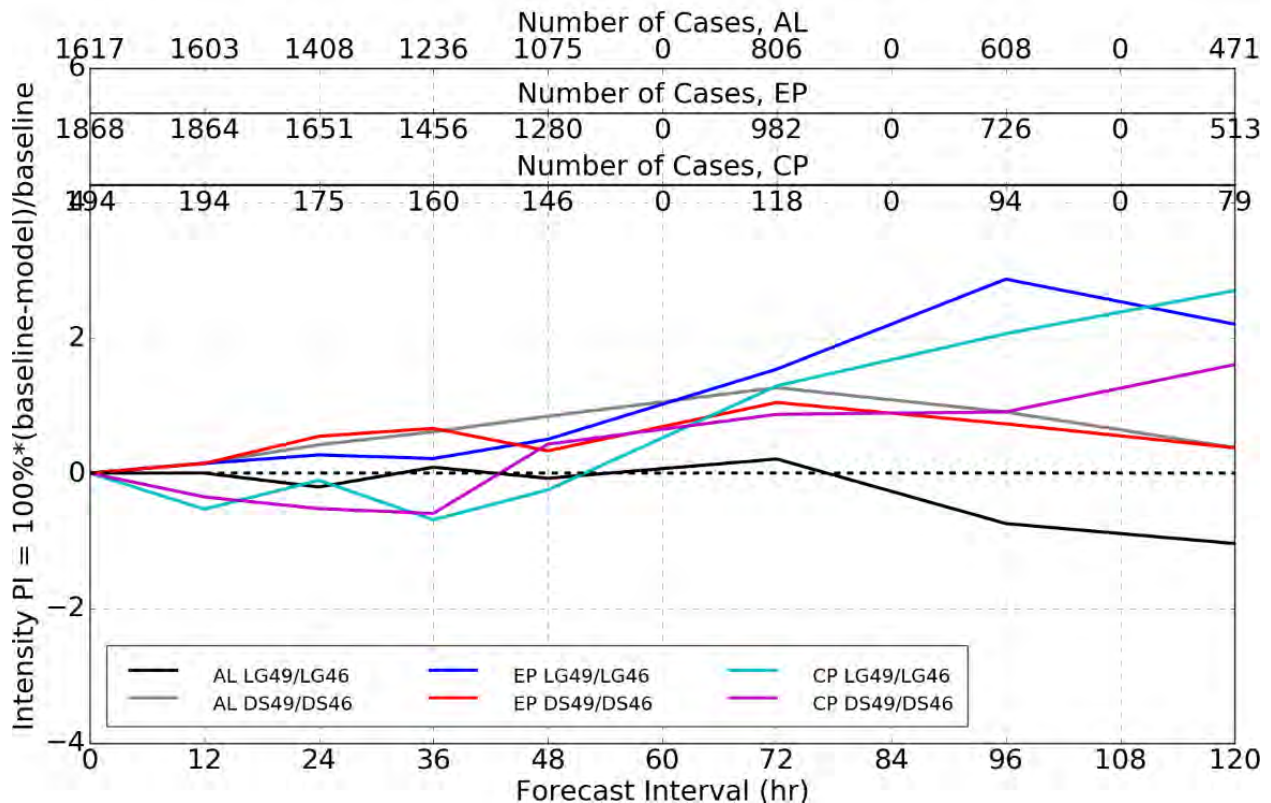

Figure 2. Left: SHIPS/LGEM dependent verification for 2010 - 2016 with daily SST for the 2016 version of the model, with RSST coefficients. Percent improvement relative to baseline version using weekly SST for Atlantic (black – LGEM, grey - SHIPS) and East (blue - LGEM; red - SHIPS) and Central Pacific (magenta - LGEM, cyan - SHIPS) basins. The most significant improvement is seen in the East Pacific for LGEM (blue line).

2) Parallel runs of SHIPS/LGEM with DAVT revealed several issues that resulted in degraded forecasts for the Atlantic basin. These issues were analyzed, and it was found that two additional steps are needed in order to get forecast improvement for the Atlantic basin. The runs used the old climatology that did not include the mixing layer depth (MLD), and the Maximum Potential Intensity (MPI) derived for the use with SST. Both issues were addressed. The updated climatology of NCODA subsurface data based on 2005 – 2015 data was developed and added to the experimental SHIPS diagnostic files. In addition, the empirical maximum potential intensity (MPI) equation has been re-derived based on DAVT assuming several constant mixing depth values. Dependent tests with the use of the new climatology and MPI produced improved results for the SHIPS with DAVT for the Atlantic, with up to 1.2 percent improvements for 6 hour forecast time with DAVT assuming 80 m constant mixing depth. The corresponding changes were incorporated to the SHIPS model and will be used for retrospective runs with the 2017 version of the models and implemented in the parallel runs during the 2017 hurricane season.

3) Parallel runs of DSWR were started at CIRA ahead of schedule, in August, 2016, and the results of these parallel runs were evaluated, provided to NHC, and presented at IHC. It was found that for the Atlantic, the DSWR had rather high MAE and strong positive biases for the 2016 season. Other models, including HWRF, GFDL, and DRCL, also suffered from similar poor performance and had high positive biases, which suggests that 2016 might have been an unusual year in the Atlantic. For the East and West Pacific,

DSWR showed a good performance for 2016, with small MAE (compared to DRCL) and almost zero biases in both of those basins. In addition and possibly most importantly, including DSWR into the multi-model consensus (RVCN, Sampson and Knaff, 2015) resulted in either improvements or no degradation to RVCN. RVCN runs included HWRF, GFS, and GFDL in addition to DSWR. The RVCN improvements with DSWR in the consensus included improved forecasts for R64 (from 0% to 28%), R50 (from 0% to 10%), and R34 (from 0% to 9%). DSWR even improved RVCN in the Atlantic, despite its poor performance there. Figure 3 shows the MAE for RVCN with (dashed bars) and without (solid bars) DSWR for Atlantic and East Pacific basins.

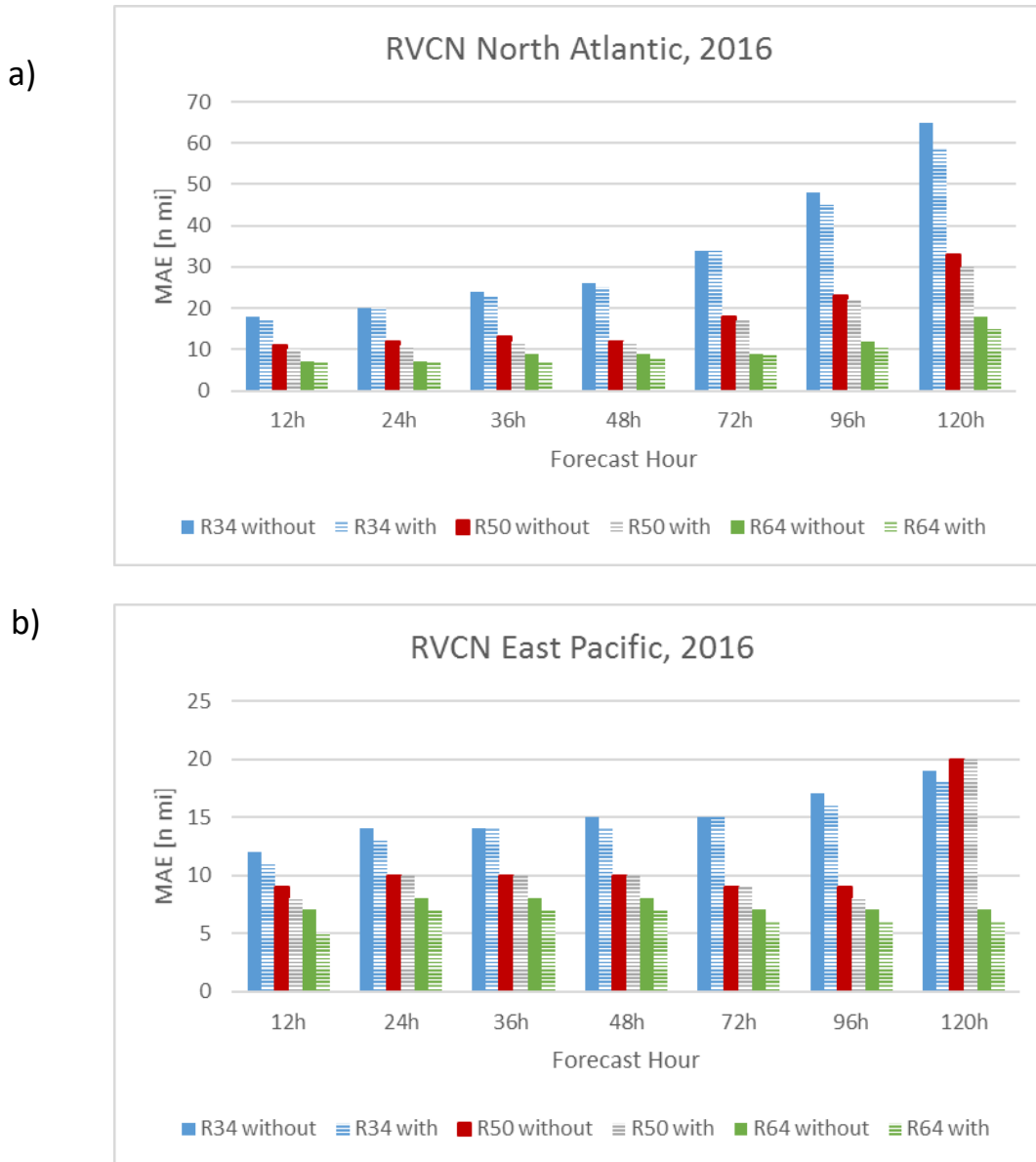

Figure 3: RVCN MAE (a) for the Atlantic and (b) East Pacific basin. RVCN included HWRF, GFS, and GFDL. Solid bars show runs without DSWR and dashed bars show runs with DSWR.

What opportunities for training and professional development has the project provided?

People working on the project obtained increased knowledge and skills in the development of statistical models. Project PI, Galina Chirokova (in 2016 and 2017), and Collaborator, John Knaff (in 2016) participated in the IHC conferences. There were no training activities during the reporting period.

How were the results disseminated to communities of interest?

1) The project results were presented at the IHC in both 2016 and 2017. The 2016 IHC presentation and previous project reports are available online at http://www.nhc.noaa.gov/jht/15-17_proj.php?large. The 2017 IHC presentation will be also available online on the same page. Additional details about the project were communicated to NHC points of contact, Dan Brown, Lixion Avila, and Chris Landsea.

2) Real-time DSWR and SHIPS/LGEM with DSST forecasts were also provided to NHC POCs via an ftp server per NHC's request.

3) The DSWR code has been provided to NHC and Naval Research Laboratory (NRL), Monterey for implementation at JTWC. The modified SHIPS/LGEM code, the global and regional daily SST data, and the new ocean data climatology together with the code for creating these datasets have been provided to NHC. The results of the verification of the retrospective and parallel runs were also provided to NHC.

What do you plan to do during the next reporting period to accomplish the goals and objectives?

During the next reporting period we plan to complete statistical tests and retrospective runs of the experimental version of the 2017 SHIPS/LGEM with DAVT assuming both constant and variable mixing depth, and derive regression coefficients for all global basins. In addition, final adjustments and modifications to the code will be implemented based on the results of the retrospective runs. We will further work with JHT and NHC TSB staff to implement experimental versions of SHIPS/LGEM and DSWR on quasi-production on WCOSS for the 2017 season and/or will implement parallel runs at CIRA. There are also plans to implement DSWR on the operational JTWC Automated Tropical Cyclone Forecast system at JTWC, where it will become a member of the RVCN forecast aid.

2. PRODUCTS

What were the major completed **products or deliverables** this period, and how do they compare to your proposed deliverables? (planned vs. actuals table recommended)

Product/Deliverable	Actual
SHIPS/LGEM code modified to work with DSST	Provided to NHC as planned
Verification of SHIPS/LGEM runs with DSST	Provided to NHC as planned
DSST database in SHIPS format for global and regional files	Provided to NHC as planned
Updated climatology for OHC, MLD, and depths of 26° (D26) and 20° (D20) isotherms	Provided to NHC in addition to what was planned
DSWR code	Provided to both NHC and JTWC as planned
Verification of DSWR runs	Provided to NHC as planned

What has the project produced?

-publications, conference papers, and presentations*;

Presentations:

Chirokova G., J. Knaff, and A. Schumacher, 2017: Improvements to operational statistical tropical cyclone intensity forecast models. *2017 Tropical Cyclone Operations and Research Forum (TCORF)/70th Interdepartmental Hurricane Conference (IHC), 13-16 March, 2017, Miami, Florida.* The presentation will be available online at http://www.nhc.noaa.gov/jht/15-17_proj.php?large.

Publication: A manuscript detailing the statistical-dynamical method to predict tropical cyclone wind structure in terms of wind radii method, its independent performance in 2014 and 2015, and how it may contribute to the wind radii consensus has been published in *Weather and Forecasting*.

Knaff, J., C. Sampson, and G. Chirokova, 2017: A global statistical–dynamical tropical cyclone wind radii forecast scheme. *Wea. Forecasting*, **32**, 629–644, doi: 10.1175/WAF-D-16-0168.1.

Highlights of that paper suggest:

1. This method (DSWR) is a competitive method for predicting the wind radii, even if the SHIPS forecasts of intensity and track are used for wind radii estimates.
2. That its inclusion in a simple wind radii consensus (RVCN), results in no degradation, and, in most cases, improves the consensus forecasts.
3. That the predictors related to mid-level moisture (+), initial size (-), storm latitude (+), 200 hPa divergence (+) are best related to changes in TC size, the sign of the relationships is shown in parentheses.

-website(s) or other Internet site(s);

- The real-time DSRW forecasts are available at <ftp://rammftp.cira.colostate.edu/knaff/DSWR/>
- The real-time SHIPS parallel runs are available at ftp://rammftp.cira.colostate.edu/chirokova/JHT_2015_2017/rt_demo/

-technologies or techniques;

- Improved (lower biased) TC vortex model for wind radii.
- Method to estimate DAVT from limited, yet routinely measured ocean parameters.

-inventions, patent applications, and/or licenses; and

None

-other products, such as data or databases, physical collections, audio or video products, software, models, educational aids or curricula, instruments or equipment, research material, interventions (e.g., clinical or educational), or new business creation.

- Database of daily Reynolds SST data converted to SHIPS input format
- Updated climatology of OHC, MDL, D26, and D20, based on the 2005 - 2015 NCODA ocean data

*For **publications**, please include a full reference and digital object identifier (DOI; <http://www.apastyle.org/learn/faqs/what-is-doi.aspx>) and attach all publications and presentations on this

project from this reporting period to the progress report, or include web links to on-line versions. Within your publications and presentations, please include language crediting the appropriate NOAA/OAR organization and program (e.g., NOAA/OAR/OWAQ and the U.S. Weather Research Program; or NOAA/OAR/NSSL and the VORTEX-SE program) for financially supporting your project. Suggested language is as follows:

"This material is based upon work supported by the U.S. Weather Research Program within NOAA/OAR Office of Weather and Air Quality under Grant No. XXXXXXXX."

3. PARTICIPANTS & OTHER COLLABORATING ORGANIZATIONS

What individuals have worked on this project?

Galina Chirokova, John Knaff, Andrea Schumacher, Robert DeMaria, Jack Dostalek

Has there been a change in the PD/PI(s) or senior/key personnel since the last reporting period?

No

What other organizations have been involved as partners? Have other collaborators or contacts been involved?

NHC points of contact have been involved. Also, work for this project has been coordinated with NHC TSB branch for setting up parallel runs.

4. IMPACT

What was the impact on the development of the principal discipline(s) of the project?

The project addresses program priorities NHC-1/JTWC- 1, NHC-13/JTWC- 10, and NHC-17/JTWC-13. The results of this project will first provide improved statistical-dynamical guidance for TC intensity. These intensity guidance techniques are routinely used operationally at NHC and JTWC to forecast TC intensity. Secondly this project developed a new statistical-dynamical forecast guidance for TC structure (i.e., wind radii) that appears somewhat independent to NWP guidance, making it a nice addition to wind radii consensus methods.

What was the impact on other disciplines?

The results of this project should allow for improved operational TC intensity and structure forecasts that are important for other agencies and general public. Improvements in these capabilities may also lead to other high priority forecasts (e.g., storm surge watch/warnings, wave forecasts) and decisions (e.g., evacuations, ship routing).

What was the impact on the development of human resources?

Nothing to report

What was the impact on teaching and educational experiences?

Nothing to report

What was the impact on physical, institutional, and information resources that form infrastructure?

Nothing to report

What was the impact on technology transfer?

Methods developed at CIRA, if approved by the JHT, will transition to NHC operations. Examples include DAVT calculations assuming constant or variable storm-induced mixing depth and a simple vortex model.

What was the impact on society beyond science and technology?

The results of this project should allow for improved operational TC intensity forecasts that are important for other governmental agencies, industry, and general public. These efforts significantly contribute to NOAA's goal of a *Weather-Ready Nation*.

What percentage of the award's budget was spent in a foreign country(ies)?

None

5. CHANGES/PROBLEMS

Describe the following:

-Changes in approach and reasons for the change.

None

-Actual or anticipated problems or delays and actions or plans to resolve them.

None

-Changes that had a significant impact on expenditures.

None

-Change of primary performance site location from that originally proposed.

None

6. SPECIAL REPORTING REQUIREMENTS

Report on any special reporting requirements here (see previous instruction #3). If there are none, state so.

- Your assessment of the project's Readiness Level (current and at the start of project; see definitions in Appendix B)

Start of the project: RL3

Current: RL5-7

-If not already reported on in Section 1, please discuss:

-- Transition to operations activities

The transition to operations for this project is scheduled after the end of Year 2, in the spring of 2018, if accepted by NHC. However, some minor computer bugs in the SHIPS/LGEM/RII processing were identified in the course of this work, and were implemented in the 2016 operational version of the NHC guidance suite on WCOSS. The project is on schedule and both the upgraded SHIPS/LGEM/RII code and new TC-structure forecast code will be ready for operational transition by summer 2017, but will need to wait until the 2018 season since NHC does not do operational model upgrades during the hurricane season. The timing of the final transition will depend on the availability of NHC Technology and Science Branch (TSB) resources.

-- Summary of testbed-related collaborations, activities, and outcomes (if it's a testbed project)

- 1) Real-time forecasts of the TC-size estimates were made available via the CIRA ftp server, server at <ftp://rammftp.cira.colostate.edu/knaff/DSWR/> starting on the 18th of August. Past forecasts made in 2016 were also provided at this time.
- 2) Real-time SHIPS forecasts with DSST were made available via CIRA ftp server at ftp://rammftp.cira.colostate.edu/chirokova/JHT_2015_2017/rt_demo/ during 2016 Atlantic and East Pacific Hurricane seasons.
- 3) Verification of the retrospective SHIPS runs with DSST and parallel runs from 2016 season were provided to NHC
- 4) 2016 version of SHIPS modified to use DSST was provided to NHC.
- 5) DSWR model was provided and tested on WCOSS for potential 2017 quasi-prod production.
- 6) Database of DSST global and regional data from 1982 – 2016 in SHIPS format was provided to NHC
- 7) Updated NCODA-based climatology of OHC, MLD, D26, and D20 was provided to NHC together with the code to create that climatology and add it to SHIPS diagnostic files
- 8) The possibility of including Decay SHIPS Wind Radii (DSWR) and MSLP estimates in operational Automated Tropical Cyclone Forecast System (ATCF) A-decks has been discussed with NHC points of contact (POCs). The implementation of DSWR in the operational A-decks for 2017 season will depend on the availability of NHC resources.
- 9) The possibility of implementing SHIPS with daily SST and DAVT in the quasi-production version of SHIPS on WCOSS for 2017 season has been discussed with NHC POCs and NHC TSB staff. The implementation of SHIPS with DSST and DAVT in the quasi-production for 2017 season will depend on the availability of NHC TSB resources.

-- Has the project been approved for testbed testing yet (if it's a testbed project)?

The transition to operations for this project is scheduled after the end of Year 2, in the spring of 2018, if accepted by NHC. The project is on schedule and both the upgraded SHIPS/LGEM/RII code and new TC-structure forecast code will be ready for operational transition by summer 2017, but will need to wait until the 2018 season since NHC does not do operational model upgrades during the hurricane season. The timing of the final transition will depend on the availability of NHC Technology and Science Branch (TSB) resources.

-- What was transitioned to NOAA?

The following software was transitioned to NOAA:

- 1) Some minor computer bugs in the SHIPS/LGEM/RII processing were identified in the course of this work, and were corrected in the 2016 operational version of the NHC guidance suite on WCOSS.
- 2) Software necessary for DSWR forecasts with updated coefficients were provided and tested on WCOSS. The implementation of DSWR is planned (personal communication, Mark DeMaria) on quasi production for forecasting during the 2017 season.
- 3) 2016 version of SHIPS model with the option to use DSST was provided to NHC.

Test Plans for USWRP-supported Testbed Projects

- I. *What **concepts/techniques** will be tested? What is the scope of testing (what will be tested, what won't be tested)?*
- The following models will be tested:
- SHIPS/LGEM with DSST
 - SHIPS/LGEM with DAVT assuming constant mixing depth
 - SHIPS/LGEM with DAVT assuming variable mixing depth
 - DSWR
- II. *How will they be tested? What **tasks** (processes and procedures) and activities will be performed, what preparatory work has to happen to make it ready for testing, and what will occur during the experimental testing?*
- 1) Tasks that will be performed during testing at CIRA:
 - run scripts to receive operational SHIPS diagnostic files in real-time
 - run scripts to add DSST, DAVT, and the new climatology to the operational diagnostic files
 - run the models
 - save the model output and make it available to NHC and JTWC via ftp
 - 2) Preparatory work:
 - complete retrospective runs using 2017 version of SHIPS/LGEM
 - derive updated coefficients for different version of SHIPS and for DSWR
 - 3) During the testing:
 - monitor model performance
 - conduct post-season verification
- III. *When will it be tested? What are **schedules and milestones** for all tasks described in section II that need to occur leading up to testing, during testing, and after testing?*
- 1) When it will be tested:
 - During the 2017 Atlantic and East Pacific hurricane seasons
 - 2) Schedules and Milestones:
 - Complete retrospective runs of modified SHIPS/LGEM (May - June 2017)
 - Coordinate with TSB staff to implement parallel runs on quasi-production on WCOSS or implement them at CIRA (May - Aug 2017)
 - Complete post-season verification (Dec 2017 - Jan 2018)
- IV. *Where will it be tested? Will it be done at the PI location or a NOAA location?*
- 1) If possible, the updated models will tested on quasi-production on WCOSS, depending on the availability of TSB resources.
 - 2) If parallel runs of experimental SHIPS/LGEM and DSWR cannot be implemented on quasi-production, they will be implemented at CIRA.
- V. *Who are the key **stakeholders** involved in testing (PIs, testbed support staff, testbed manager, forecasters, etc.)? Briefly what are their **roles and responsibilities**?*
- Stakeholders and Roles:
- PIs: prepare model: provide code and data to NHC, conduct parallel runs at CIRA if needed
 - TSB staff and JHT support staff: if possible, implement updated models on quasi-production on WCOSS. Evaluate the new products and provide feedback.
 - JHT POCs: monitor the model performance and provide feedback to PIs

- VI. *What **testing resources** will be needed from each participant (hardware, software, data flow, internet connectivity, office space, video teleconferencing, etc.), and who will provide them?*
- The updates models require resources similar to the operational versions. Existing hardware and software will be used for testing on quasi-production on WCOSS and/or at CIRA.
- VII. *What are the **test goals, performance measures, and success criteria** that will need to be achieved at the end of testing to measure and demonstrate success and to advance Readiness Levels?*
- 1) Test goals:**
- Evaluate the performance of the updated and new models
 - Compare experimental parallel runs with operational runs
 - Provide testing results to NHC and JTWC and respond to feedback
- 2) Performance measures:**
- Model verification with the algorithms that are used to evaluate the performance of the operational models
- 3) Success criteria:**
- Performance of the experimental models compared to the performance of the operational models
- VIII. *How will testing **results** be documented? Describe what information will be included in the **test results final report**.*
- Test results will be provided to NHC and JHT in the final project report and test results final report.
- 1) The documentation of the test results will include:
- the results of retrospective model verification
 - the results of the post season verification of real-time runs.
- 2) The test results final report will include the result of the retrospective model verification. The post season verification cannot be completed until the end of the hurricane season, therefore these results might not be available in time to be included in the test results final report.

7. BUDGETARY INFORMATION

Is the project on budget? Much of the quantitative budget information is submitted separately in the Federal Financial Report. However, describe here any major budget anomalies or deviations from the original planned budget expenditure plan and why.

The project is on budget

8. PROJECT OUTCOMES

What are the outcomes of the award?

The improved version of the operational statistical-dynamical models for forecasting TC intensity is being developed. The new statistical dynamical model for forecasting TC wind radii has been developed.

Are performance measures defined in the proposal being achieved and to what extent?

The performance measures defined in the proposal (the milestones) are being achieved as planned.

9. REFERENCES

- Knaff, J., C. Sampson, and G. Chirokova, 2017: A global statistical–dynamical tropical cyclone wind radii forecast scheme. *Wea. Forecasting*, **32**, 629–644, doi: 10.1175/WAF-D-16-0168.1.
- Knaff, J. A., S. P. Longmore, and D. A. Molenaar, 2014a: An Objective Satellite-Based Tropical Cyclone Size Climatology. *J. Climate*, **27**, 455–476. doi: <http://dx.doi.org/10.1175/JCLI-D-13-00096.1>
- I.-I. Lin, P. Black, J. F. Price, C.-Y. Yang, S. S. Chen, C.-C. Lien, P. Harr, N.-H. Chi, C.-C. Wu and E. A. D'Asaro, 2013: An ocean coupling potential intensity index for tropical cyclones. *Geophysical Res. Letters*, **40**, 1878–1882. DOI: 10.1002/grl.50091
- Price, J. F., 2009: Metrics of hurricane-ocean interaction: vertically-integrated or vertically-averaged ocean temperature. *Ocean Sci.*, **5**, 351-368, doi:10.5194/os-5-351-2009.
- Sampson, C. R., and J. A. Knaff, 2015: A consensus forecast for tropical cyclone gale wind radii. *Wea. Forecasting*, **30**, 1397–1403, doi:10.1175/WAF-D-15-0009.1.
- Yablonsky, R.M. and I. Ginis, 2009: Limitation of One-Dimensional Ocean Models for Coupled Hurricane–Ocean Model Forecasts. *Mon. Wea. Rev.*, **137**, 4410–4419, doi: 10.1175/2009MWR2863.1.

Appendix B

NOAA READINESS LEVELS (RLs)

There are nine readiness levels defined in NOAA Administrative Order 216-105A as follows:

A. Research

RL 1: Basic research: experimental or theoretical work undertaken primarily to acquire new knowledge of the underlying foundations of phenomena and observable facts, without any particular application or use in view. Basic research can be oriented or directed towards some broad fields of general interest, with the explicit goal of a range of future applications;

RL 2: Applied research: original investigation undertaken in order to acquire new knowledge. It is, however, directed primarily towards a specific, practical aim or objective. Applied research is undertaken either to determine possible uses for the findings of basic research or to determine new methods or ways of achieving specific and predetermined objectives.

B. Development

RL 3: Proof-of-concept for system, process, product, service or tool; this can be considered an early phase of experimental development; feasibility studies may be included;

RL 4: Successful evaluation of system, subsystem, process, product, service or tool in laboratory or other experimental environment; this can be considered an intermediate phase of development;

RL 5: Successful evaluation of system, subsystem process, product, service or tool in relevant environment through testing and prototyping; this can be considered the final stage of development before demonstration begins;

C. Demonstration

RL 6: Demonstration of prototype system, subsystem, process, product, service or tool in relevant or test environment (potential demonstrated);

RL 7: Prototype system, process, product, service or tool demonstrated in an operational or other relevant environment (functionality demonstrated in near-real world environment; subsystem components fully integrated into system);

RL 8: Finalized system, process, product, service or tool tested, and shown to operate or function as expected within user's environment; user training and documentation completed; operator or user approval given;

D. Deployment

RL 9: System, process, product, service or tool deployed and used routinely.

PROJECT TITLE: Improving CarbonTracker Flux Estimates for North America using Carbonyl Sulfide (OCS)

PRINCIPAL INVESTIGATOR(S): Huilin Chen (CIRES/CU); Ian Baker (CIRA/CSU)

RESEARCH TEAM: Huilin Chen (CIRES/CU, U. Groningen); Wei He (U. Groningen); Ivar van der Velde (U. Groningen); Wouter Peters (U. Groningen); Andrew Jacobson (CIRES/CU); Arlyn Andrews (NOAA/ESRL); Steve Montzka (NOAA/ESRL); Ian Baker (CIRA/CSU);

PROJECT OBJECTIVES Timeframe May 1, 2015 – April 30, 2016:

1--Improve the estimate of net carbon fluxes of North America using our newly developed CarbonTracker_Lagrange CO₂ system;

2--Perform biospheric parameter inversions using our newly developed CarbonTracker-Lagrange-SiB CO₂ and OCS system, and improve the estimate of both net and gross carbon fluxes;

3--Develop and test mechanistic representations of carbonyl sulfide (OCS) within land surface models and evaluate and quantify relationships between OCS flux and CO₂ biophysics.

PROJECT ACCOMPLISHMENTS:

1--Results from the CarbonTracker-Lagrange CO₂ system

We continued to develop the CarbonTracker-Lagrange CO₂ system by designing and testing an innovative boundary condition optimization scheme, performing sensitivity runs with different model setups, and comparing our results with previous studies.

1)Innovative boundary condition optimization scheme

For regional studies, the accurate representation of boundary conditions is important to derive unbiased

$$C(x, y, z, t) = F(x, y, \tau) \otimes f(x, y, z, t) + BC(x, y, z, t) + \beta * f_{bc}$$

fluxes, shown in the following equation:

Where C is the simulated concentration; F is surface fluxes; f is the footprint; BC is the initial value before entering the regional domain. Clearly, the potential bias in the BC estimate will have a direct impact on the optimized fluxes. To solve this issue, we have added an additional term $\beta * f_{bc}$ so that surface fluxes and boundary conditions can be optimized simultaneously. In the ideal case, the three-dimensional background fields over time should be optimized based on the actual influencing areas of the observations; however, this will significantly complicate the system. Instead, we have chosen to optimize four BC parameters, labeled as $\beta_1, \beta_2, \beta_3, \beta_4$ to represent the individual bias correction for each wall of our domain (see Fig.1).



Figure 1. The schematics of the boundary condition optimization scheme: the four parameters β_1 , β_2 , β_3 , β_4 represent the mean bias corrections for the four sides of our domain within consecutive 10-day windows.

2) Results from the boundary condition optimization

First, the optimized four boundary condition parameters are shown in Figure 2. The prior parameters are set to a mean of zero, shown in blue lines and the optimized parameters are shown as green lines, with the uncertainties given as the shaded areas. The prior parameters are assigned a standard deviation of 1.4 ppm. Notice that the uncertainties of all optimized parameters have been reduced compared to those of the prior ones, however, the boundary parameter uncertainty reduction is maximized for the west boundary, due to the prevailing wind from the west to the east and therefore more data constraints compared to other boundary parameters.

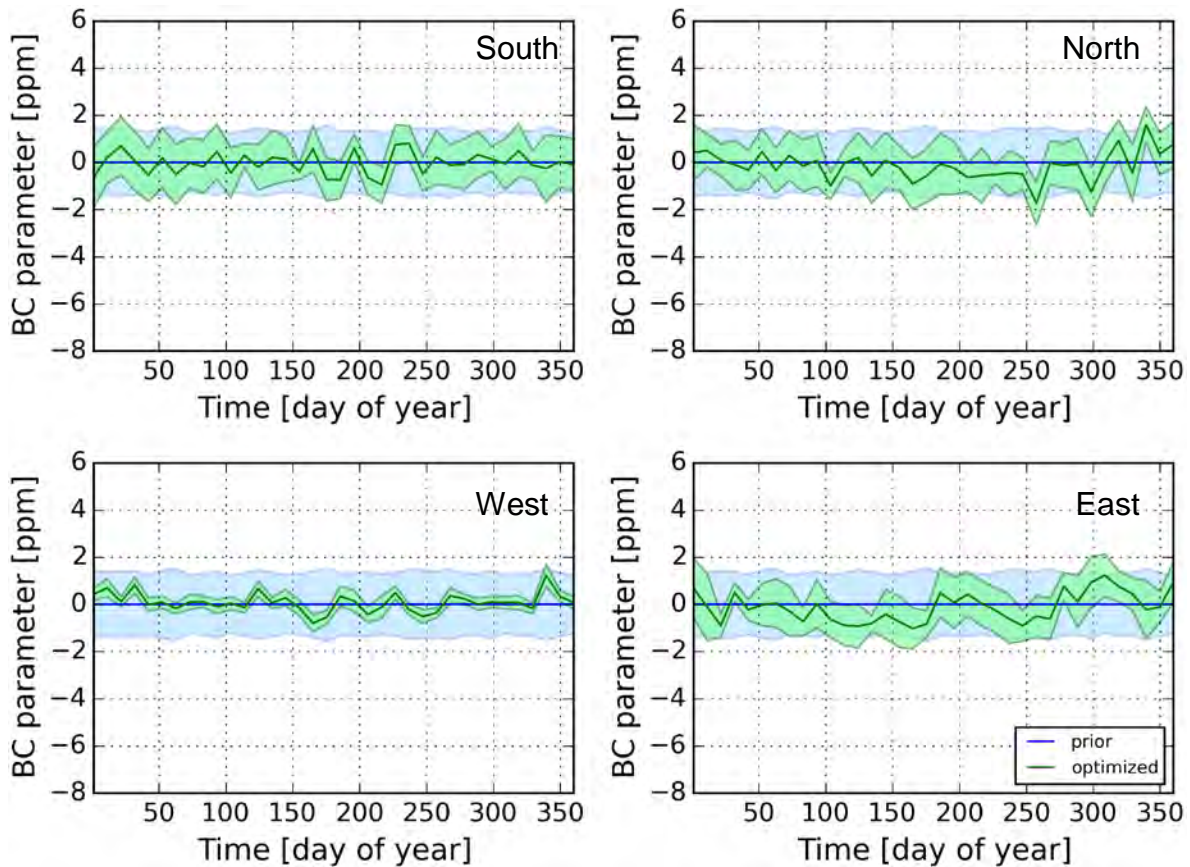

Figure 2. The boundary condition parameters for four sides of the domain, labeled as South, North, West, East. The prior parameters are shown in blue lines, and the optimized parameters are given in green lines. The shaded areas indicate the parameter uncertainties.

The contribution from the flux adjustment (convolved with footprints) and the boundary condition adjustment to CO₂ concentrations is shown in Figure 3. The curves represent 10-day averages of the corresponding adjustment over all sites for 2010. The flux and the boundary condition adjustments are on the same order of magnitude, however, the total adjustment is in most cases dominated by the flux adjustment, with relatively large contributions from the boundary condition adjustment for certain periods, e.g. in the spring and in the fall.

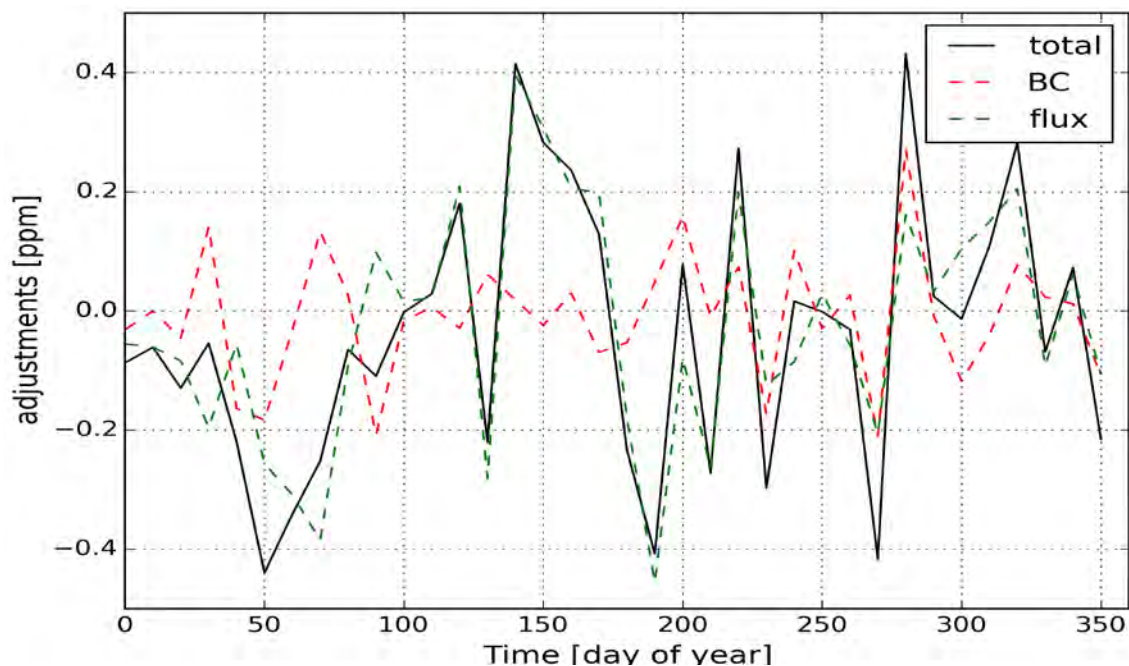

Figure 3. The contribution from the flux adjustment and the boundary condition adjustment to CO₂ concentrations for the year of 2010. The dashed line (red) shows the boundary condition adjustment, the dashed line (green) indicates the flux adjustment, and the total adjustment is shown as the solid line (black).

3) Results from the sensitivity model runs

To evaluate the uncertainties of the optimized fluxes, we have performed a series of sensitivity model runs as alternatives to the base run setup. The major setup parameters for the base run case are summarized in Table 1.

Table 1. The base run setup

Biosphere fluxes	SiBCASA
Covariance of biosphere fluxes	80%
Boundary condition	CarbonTracker North America 2013B
Uncertainties of boundary condition	1.4 ppm
Model-data-mismatch	3 ppm for surface sites, 1 ppm for aircraft sites
Transport	WRF-STILT

For the sensitivity studies, we have made an ensemble of model runs by modifying one of the major setup parameters, listed in Table 2. Besides these, we performed one additional model run, in which the observations from BAO and WGC have been excluded. It is evident that the two sites are influenced more by fossil fuel emissions than other sites; however, our fossil fuel simulations are not well represented due to the coarse fossil fluxes.

Table 2. A summary of model sensitivity runs

BC1	CarbonTracker-Europe as boundary conditions
BC2	Empirical curtain as boundary conditions
B1	Use SiB3 fluxes as prior
B2	Use CarbonTracker North America 2013B as prior
R1	Assign the mdm for surface sites to 2 ppm
R2	Assign the mdm for surface sites to 4 ppm
Q1	Assign the covariance of biosphere fluxes to 150%
Q2	Assign the covariance of biosphere fluxes to 250%
Pbc1	Assign the uncertainty of boundary condition to 0.5 ppm
Pbc2	Assign the uncertainty of boundary condition to 2.5 ppm
Obs	Excluding two sites BAO and WGC

As an example, the model run results with different biosphere prior fluxes (SiBCASA, SiB3, CarbonTracker-NA2013B) are shown in Figure 4. The three prior fluxes exhibit significant differences, which to a large extent influences the optimized fluxes, especially in the fall. Nevertheless, the optimized fluxes do converge in the winter season, and the optimized fluxes in summer are getting closer than the priors are.

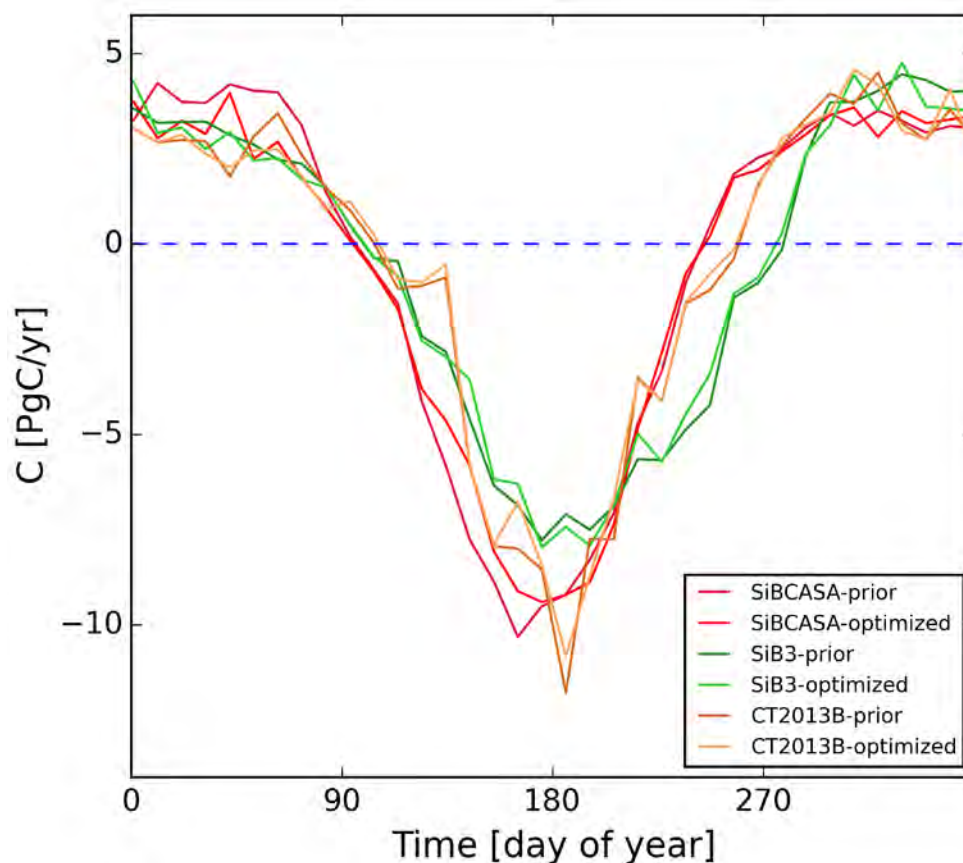

Figure 4. The optimized biospheric fluxes derived from model runs with different biospheric fluxes as priors for the year 2010.

The optimized biospheric fluxes for all the model sensitivity runs are shown in Figure 5. The estimates fall between -0.6 and -0.4 PgC/yr, which is in the similar range as the results from other models, e.g. -0.4 PgC/yr from CarbonTracker North America, -0.6 PgC/yr from CarbonTracker Europe, as well as an inventory-based estimate of -0.5 PgC/yr from Pacala et al. in 2007.

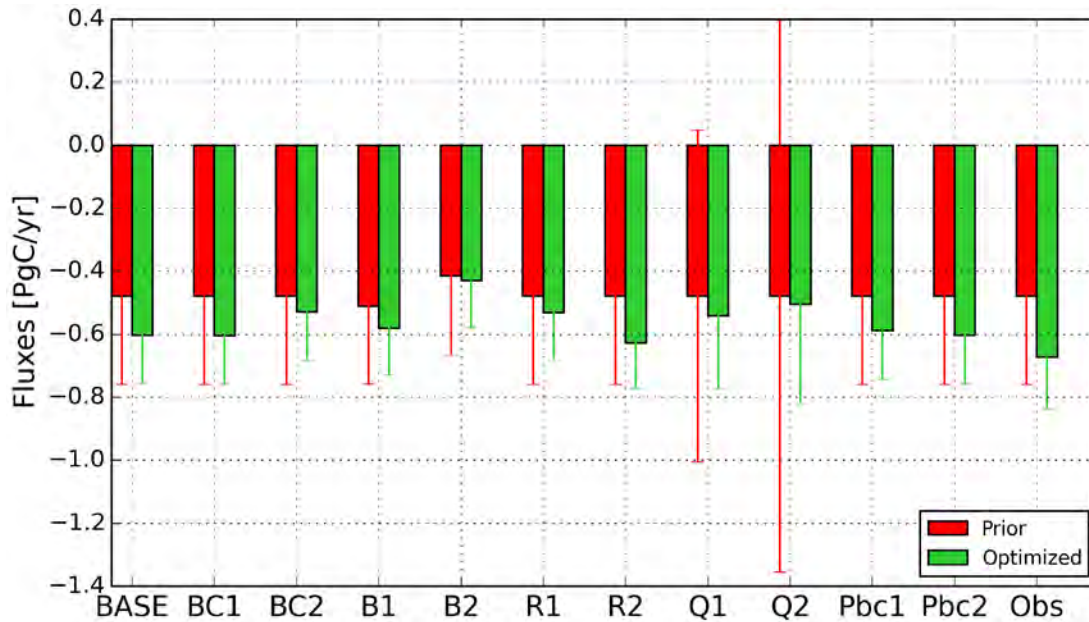

Figure 5. The optimized biospheric fluxes derived from an ensemble of model runs listed in Table 2 for the year 2010. The prior is given in red bar, and the optimized is given in green bar for each individual run.

2--Results from the CarbonTracker-Lagrange-SiB CO₂ and OCS system

Furthermore, we have performed parameter inversions based on the SiB4 model using the CarbonTracker-Lagrange system. The system assimilated both CO₂ and OCS to simultaneously optimize NEE and GPP.

1) Model parameter inversion setup

Inversion results from the optimized parameters of the biosphere model provide us insightful knowledge to improve our understanding on the processes that control carbon fluxes, however, it is necessary to solve the non-linearity issue, and is often computation expensive. Our ensemble Kalman filter based system CarbonTracker-Lagrange is able to handle a certain level of nonlinearity. The use of atmospheric measurements of both CO₂ and OCS enable us to partition NEE to GPP and respiration.

To begin with, we have selected the parameters for the inversion system, listed in Table 3. The list includes in total 28 parameters: Vmax0 (the maximum capacity to turn CO₂ into sugars) and soil respiration for 13 major plant function types in North America plus two values for the m parameter (C3 and C4 plants).

Table 3. The selected parameters for the inversion based on the SiB model and the CarbonTracker-Lagrange system

	Dimension	Sensitive to	Prior uncertainty
Vmax0	13 (for each pft)	F_{GPP} and F_{OCS_plant}	20%
Soil Respiration	13 (scalable parameters for each pft)	F_{soil}	20% (covarying with Vmax0)
m	2 (mc3 = 9 mc4 = 4)	F_{GPP} and F_{OCS_plant}	20%

We found out that it is necessary to set the respiration parameter covarying with Vmax0 to maintain a correct NEE budget (see Figure 6).

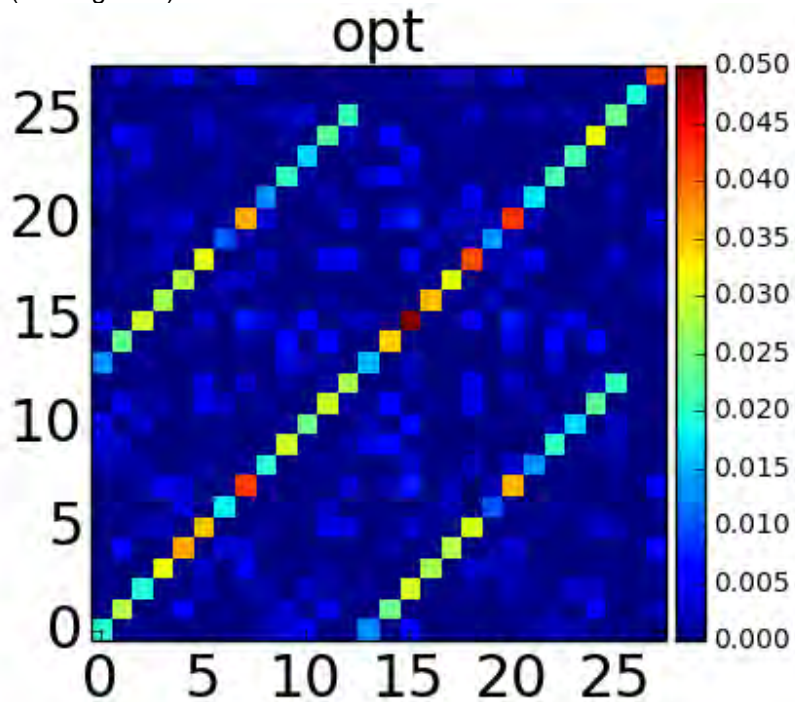

Figure 6. The covariance matrix of the optimized 28 parameters. The diagonal values indicate the covariance of the corresponding parameters, Vmax0 and Respiration.

2) Results from the parameter inversions

The differences between the optimized and the prior fluxes are shown in Figure 7. This is likely driven by evergreen needleleaf (most dominant there) and winter/spring wheat pft's. In comparison to prior estimates, the annual GPP and OCS plant uptake is reduced by 0.9 PgC/yr and 7.1 GgS/yr, respectively. Annual NEE sink is reduced with 0.45 PgC/yr, from -0.99 PgC/yr to -0.55 PgC/yr. Largest adjustments are made in the mid-west that are dominated by maize and soybean pft's. The same region where we had a

large prior sink becomes now a negative GPP anomaly. In the southeast United States we see an increase in GPP and OCS plant uptake, mainly in April and October.

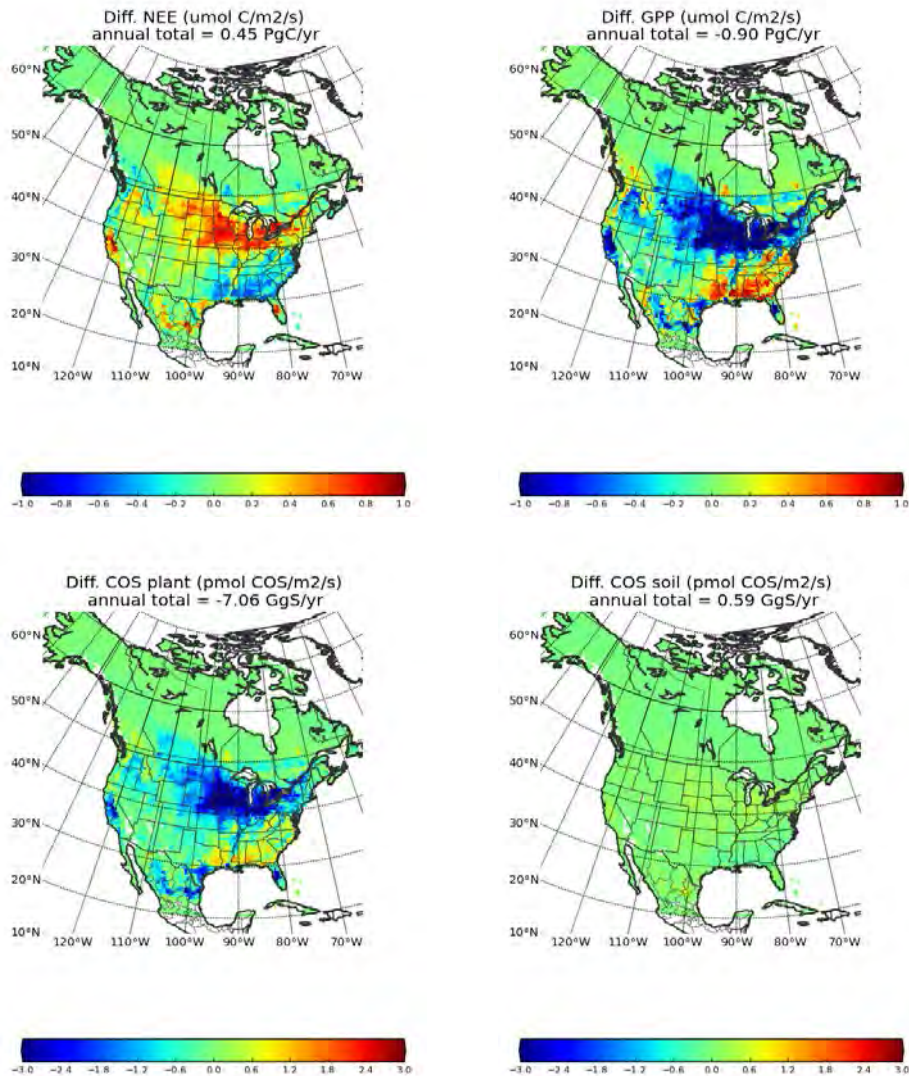

Figure 7. Difference between optimized (mdm of 40ppt) and prior fluxes for NEE, GPP, OCS plant uptake. Notice that the difference between OCS soil uptake is caused by the dependence of soil uptake on soil respiration.

The reductions in GPP and respiration correspond with changes in model parameters (see Fig.8). On y axis shows the labels of each ecosystem type, and the months are shown on the x axis. Relative reductions of the parameters are shown by blue colors. The GPP reductions at corn belt are clearly driven by reductions in V_{max0} , whereas GPP increases in the boreal forest are driven by increases of V_{max0} . Respiration parameter is highly correlated with V_{max0} . Variations in the m parameter seem more subtle, might point towards a slight different stomatal response to relative humidity.

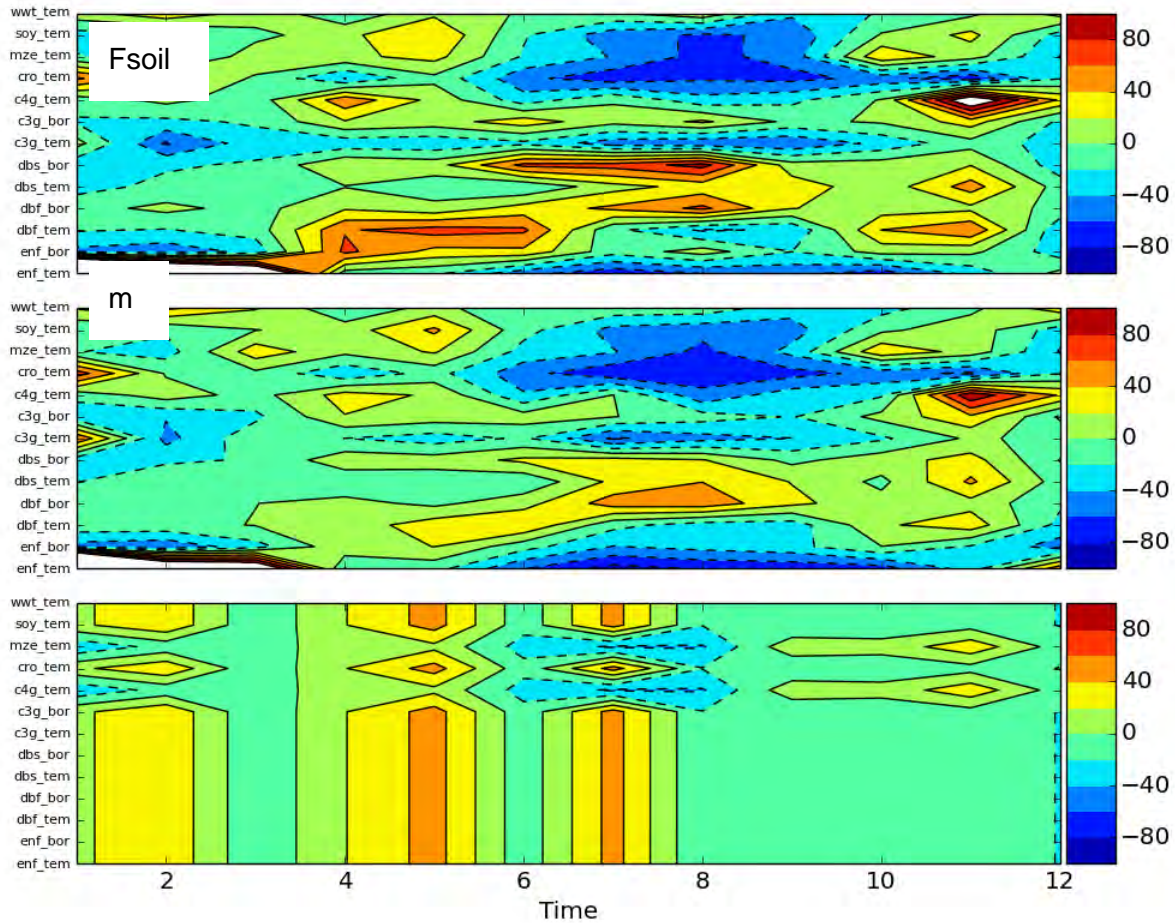

Figure 8. The optimized parameters of Vmax0, Soil respiration, and m. Monthly values for each plant function type is derived. The colors indicate the relative change of the parameters in percent.

3) Comparison with eddy covariance measurements

We tested the optimized GPP fluxes from SiB4 with actual measured GPP fluxes at two eddy covariance sites in North America. Between Harvard forest and Lost creek Wisconsin, we can capture only certain periods correctly. Optimized is in red and prior in green. For Harvard we improved the early growing season GPP peak, whereas for Wisconsin we only improved the midseason GPP. We shall see the current results more as prove of concept, as these are the first ever model parameter optimizations with CarbonTracker, and further improvements are foreseen in the near future.

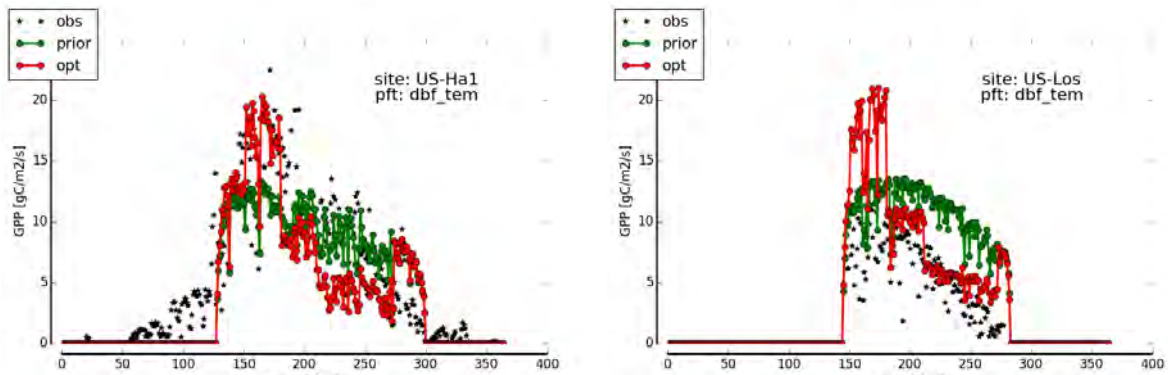

Figure 9. Comparison of modeled and measured GPP at Harvard forest, Massachusetts (left), and at Lost Creek, Wisconsin (right).

3--Develop and test mechanistic representations of carbonyl sulfide (OCS) with SiB4

1) Site simulation Harvard Forest (US-Ha1)

We reported on these simulations last year, but a short reminder of the main points of Commane et al. (2015) seems relevant. We provided simulations of latent/sensible heat, carbon flux, and OCS flux at US-Ha1 for comparison to observations. We found that at US-Ha1, it is incorrect to assume a constant ratio of CO₂ to OCS uptake. You cannot multiply GPP by a Leaf Relative Uptake (LRU) term to obtain OCS flux, either for observations or simulations. This suggests that process-based models are required for simulations of OCS flux, and their use and interpretation in constraining simulations of CO₂ flux.

Also, Commane et al. described a large OCS source term during the hottest months of summer 2013. This result has encouraged much thought about flux of OCS into and out of the soil, and our ability to understand it (and therefore gain an ability to simulate it). We are currently collaborating with groups that study soil flux of OCS at Stanford and UCLA, with hopes of fine-tuning our simulated OCS soil flux. When soil flux is into the soil, it is our experience that the soil term is much smaller than OCS uptake by leaves (from one-third to one-half as large). However, a soil efflux of OCS can overwhelm the leaf uptake (as in July 2013 at US-Ha1). It is becoming apparent that the soil term is an important, and relatively unknown, component of the total OCS budget at the land surface.

2) Site simulation Hyytiala Finland (FI-Hyy)

We simulated surface fluxes for the Hyytiala tower site in Finland, for years 2010-2015, and evaluated model performance over the summer months (Jun-August) for 2015. We find that both CO₂ and OCS have flux magnitude that is too small in the model. However, we can see that the LRU (right panel in Figure 10) is almost spot-on until the late afternoon.

This is important. That the simulated LRU is very close to observed suggests that the simulated OCS flux is reasonable. At FI-Hyy something is happening in the model that results in insufficient uptake of both CO₂ and OCS; these can be insufficient leaf area, unrealistic stress, or incorrect parameter values (such as V_{max}, Rubisco velocity). In this case we have the ability to postulate hypotheses around model behavior and suggest modifications. We are currently looking into these research avenues.

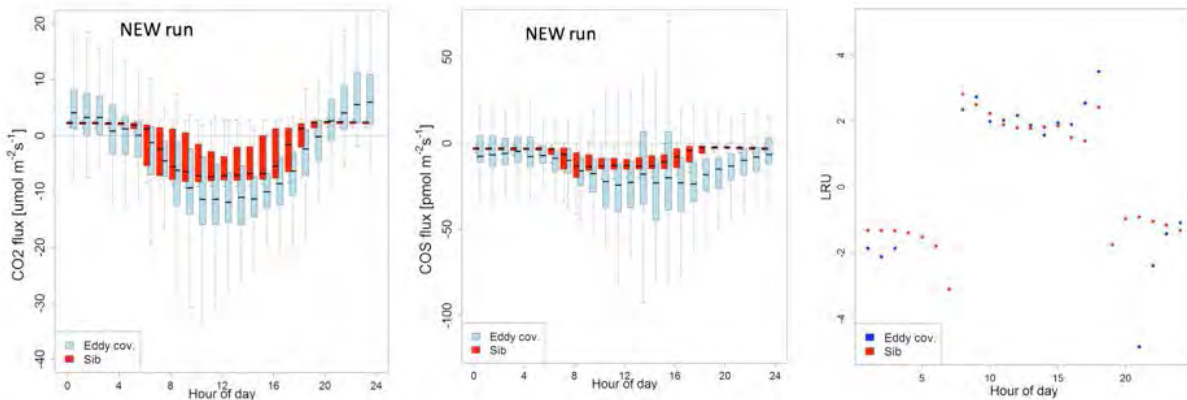

Figure 10. Diurnal composites from Hyytiälä, Finland, for CO₂ flux (left), OCS flux (center), and leaf relative uptake (LRU, right) for summer months 2015.

However, there is a caution. We've been very aware of ground OCS flux as we compare our simulated flux to observations. It appears that when the ground OCS flux is an uptake term, the flux is small relative to the leaf uptake component. When the ground term is positive (efflux into the atmosphere), it causes large excursions in the observed flux relative to simulations. We saw this at Harvard Forest (above). In this particular case, it appears that our soil OCS flux is reasonably simulated, and is an uptake term. When we see reasonable LRU simulation when compared to observed, it does not result in the kind of 'what the heck is going on' questions that have arisen at Harvard Forest or the Midwest US, but rather provides some assurance that the processes and mechanisms in the model are reasonable for this site, during this time period.

3) Regional studies Kuai et al., ocean flux

In Berry et al. (2013), one of the first simulations of the global OCS budget, it was postulated that an oceanic source much, much larger than the accepted value was required to balance global plant and soil uptake terms. Aircraft samples have supported the existence of this tropical ocean OCS source term (I recall Steve Wofsy describing some initial HIPPO results by saying "we found an OCS source right where Joe Berry said it would be."), but spatiotemporal quantification is ongoing. Kuai et al. (2015) used Aura Tropospheric Emission Spectrometer (TES) observations as well as inversions to quantify the Pacific Ocean OCS source. We contributed terrestrial OCS fluxes that were used as part of the 'prior' in the inversion.

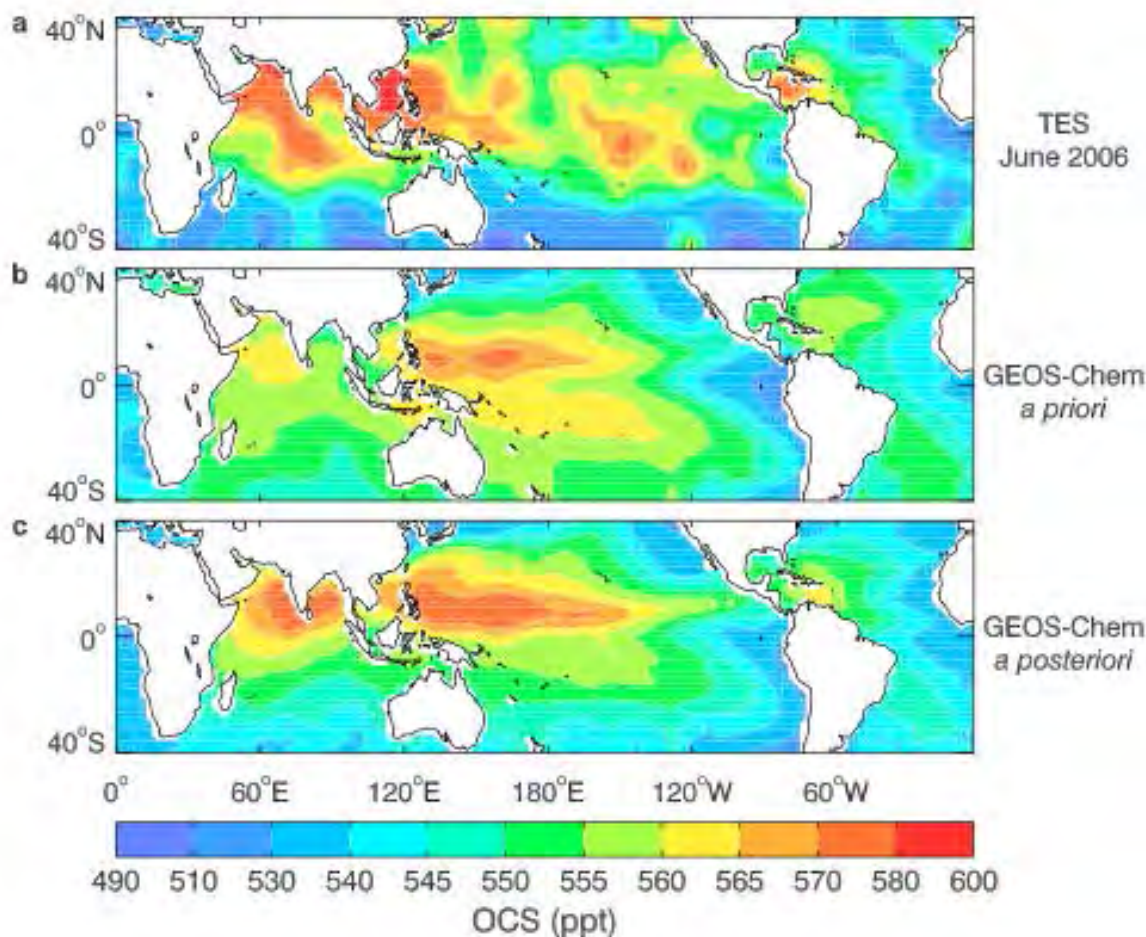

Figure 11. Pacific Ocean OCS flux for June 2006 from Aura TES (top), inversion a priori (middle) and inversion a posteriori (lower). From Kuai et al., 2015.

This result is further confirmation of the postulated ocean source described in Berry et al. (2013). Constraint and understanding of the oceanic source term will reduce uncertainty in global OCS budgets, simulations and inversions, allowing more critical interpretation of model and inversion results.

4) Regional studies Glatthor et al., Tropics

This study has similarity with Kuai et al. Glatthor used spaceborne measurements of OCS from the Michelson Interferometer for Passive Atmospheric Sounding (MIPAS) to measure tropical OCS concentration at 250 hPa. They found a region of OCS enhancement in the tropical Pacific Ocean similar to that suggested by Berry et al. (2013), as well as a large drawdown over tropical South America. These results, along with those of Kuai et al. suggest that the large ocean source term indicated by Berry et al. (2013) is realistic.

The large drawdown of OCS over tropical land is important for two reasons: 1) The NET carbon flux over Amazonia is extremely complex, with complicated interactions between photosynthesis and respiration components that make quantification of the continental-scale CO₂ flux seasonality elusive. However, the large drawdown of OCS during Austral summer, which is essentially the wet season, supports the idea that large-scale GPP seasonality is tied to moisture availability. This suggests that large-scale GPP is

controlled by biotic factors (water limitation, or 'biotic control' in the nomenclature of Costa et al., 2010), as opposed to light limitation ('environmental control'), with the understanding that smaller regions are heterogeneously dominated by water- or light-limitation. 2) Huntzinger et al. (2012) demonstrated that models can agree on overall carbon exchange (Net Ecosystem Exchange, NEE) while simulating GPP and respiration components that differ by a factor of two or more. The SiB OCS drawdown over tropical South America had similar magnitude to that observed by MIPAS (Figure 3); this provides support (not complete verification) that SiB3 GPP in South America is reasonable.

5) Regional studies Wang et al., terrestrial flux

We talked a bit about this paper in last year's report; therefore a short summary should suffice. Wang et al. used solar absorption Fourier Transform InfraRed spectrometry to obtain co-located measurements of OCS and CO₂ at 5 Northern Hemisphere sites. They compared these observations with simulated concentrations obtained by running several surface flux models through a transport model. We provided one of the surface flux products.

The SiB fluxes provided a good comparison with the CO₂ observations. OCS uptake was excessive in high northern latitudes in springtime, and underestimated in the late summer and early fall. Since CO₂ concentration results from co-located sink (photosynthesis) and source (respiration) terms, it is possible to obtain correct CO₂ concentration with erroneous component fluxes. The OCS comparison suggests that our model (SiB) has excessive plant activity in early spring (Boreal), and that plant activity ceases too early in the fall. Also, there is some evidence that SiB plant activity is unrealistically small in the arctic (tundra), a result supported by another model intercomparison study (Fisher et al., 2014).

Summary

Within the project, we have developed the CarbonTracker-Lagrange CO₂ system, and extended it to include OCS and performed the parameter inversions. The system is not only able to improve the estimate of North American net carbon fluxes, but also of the gross carbon fluxes. Furthermore, the optimized parameters helped us understand the model simulations on the process level, increasing our ability to predict the responses of system under the ongoing climate change.

We are also making great strides in our understanding of and ability to simulate the global OCS budget. First, we are finding continued support for the large OCS source in tropical oceans suggested initially by Berry et al. (2013). Aircraft and satellite studies are quantifying that spatiotemporal behavior of this term. Secondly, there is support for the magnitude of tropical GPP simulated by SiB, but we still consider this an ongoing topic for research rather than a conclusion. Also, there is continuing evidence that SiB GPP (and OCS uptake) is anomalously small in high latitudes of the Northern Hemisphere.

Soil OCS flux quantification continues to be elusive. We are working with the community on this problem, and expect improved simulation results in the coming weeks. CSU will continue to have close communication with Dr. Chen and his team, as we expect to have multiple iterations of the inversion process; this isn't the kind of problem where you run it once and the result is publishable. The framework is in place, and we will spend the final year of the project putting it to work. Concurrently, we are continuing to improve our understanding and ability to simulate OCS (and CO₂) fluxes; as our a priori fluxes improve, the inversion framework will become more robust.

Publications:

Baker, I., and coauthors 2015: Constraining global photosynthesis: can we use novel methods to increase our understanding of vegetation behavior? Invited oral presentation, University of Wageningen, Wageningen Netherlands, 13 Oct 2015.

Berry, J.A., I. Baker, E. Campbell, C. van der Tol, A. Kornfeld, K. Guan, 2015: Can we bring discipline to carbon cycle modeling using observations of solar induced fluorescence and carbonyl sulfide? Oral Presentation, American Geophysical Union Fall Meeting, San Francisco CA, 14-18 December 2015.

Berry, J.A., J.E. Campbell, I. Baker, M. Whelan, T. Hilton, 2015: Carbonyl Sulfide: is it an isotope of CO₂ on Steroids? Oral Presentation, American Geophysical Union Fall Meeting, San Francisco CA, 14-18 December 2015.

Chen, H., He. W., W. Peters, A. Andrews, A. Jacobson, C. Sweeney, I. Baker, I. van der Laan-Luijkx, I. van der Velde, P. Tans, 2015: A Lagrangian Assimilation System for North American Carbon Flux Estimates. Poster presentation, American Geophysical Union Fall Meeting, San Francisco CA, 14-18 December 2015.

Glatthor, Norbert, Michael Hpfner, Ian T. Baker, Joe Berry, Elliott Campbell, Stephan R. Kawa, Gisele Krysztofiak, Björn-Martin Sinnhuber, Gabriele Stiller, Jim Stinecipher, and Thomas von Clarmann, 2016: Poster presentation, European Geosciences Union General Assembly, Vienna Austria, 17-22 April 2016.

He, Wei, Huilin Chen, Ivar van der Velde, Arlyn Andrews, Colm Sweeney, Ian Baker, Weimin Ju, Ingrid van der Laan-Luijkx, Pieter Tans, and Wouter Peters, 2016: CarbonTracker-Lagrange: A model-data assimilation system for North American carbon flux estimates. Oral Presentation, European Geosciences Union General Assembly, Vienna Austria, 17-22 April 2016.

Kooijmans, Linda M.J. , Kadmiel Maseyk, Ulli Seibt, Timo Vesala, Ivan Mammarella, Ian T. Baker, Alessandro Franchin, Pasi Kolari, Wu Sun, Helmi Keskinen, Janne Levula, and Huilin Chen, 2016: Stomata-controlled nighttime COS fluxes in a boreal forest: implications for the use of COS as a GPP tracer. Oral Presentation, European Geosciences Union General Assembly, Vienna Austria, 17-22 April 2016.

Kuai L., John Worden, Elliott Campbell, Susan Kulawik, Meemong Lee, Stephen Montzka, Joe Berry, Ian Baker, Scott Denning, Randy Kawa, Huisheng Bian, and Yuk Yung: Quantification of A Tropical Missing Source From Ocean For The Carbonyl Sulfide Global Budget. Poster Presentation, European Geophysical Union General Assembly 2015, Vienna Austria, 12-17 April 2015.

Wang, Yuting, Julia Marshall, Mathias Palm, Nicholas Deutscher, Christian Roedenbeck, Thorsten Warneke, Justus Notholt, Ian Baker, Joe Berry, Parvatha Suntharalingam, Nicholas Jones, Emmanuel Mahieu, Bernard Lejeune, James Hannigan, Stephanie Conway, Kimberly Strong, Elliott Campbell, Adam Wolf, and Stefanie Kremser, 2016: Using NDACC column measurements of carbonyl sulfide to estimate its sources and sinks. Oral Presentation, European Geosciences Union General Assembly, Vienna Austria, 17-22 April 2016.

Wang Y., Christof Petri, Mathias Palm, Thorsten Warneke, Ian Baker, Joe Berry, Parvatha Suntharalingam, Elliott Campbell, Adam Wolf, Nick Deutscher, and Justus Notholt: Using Carbonyl Sulfide column measurements and a Chemical Transport Model to investigate variability in biospheric CO₂ fluxes. Poster Presentation, European Geophysical Union General Assembly 2015, Vienna Austria, 12-17 April 2015.

Wehr, R., R. Commane, I. Baker, J. Munger, S. Saleska, S. Wofsy, 2015: What controls the Net Forest-Atmosphere exchange of Carbonyl Sulfide? Results from 2 years of eddy covariance observations and SiB model simulations. Oral Presentation, American Geophysical Union Fall Meeting, San Francisco CA, 14-18 December 2015.

PROJECT TITLE: Improving Probabilistic Forecasts of Extreme Rainfall through Intelligent Processing of High-resolution Ensemble Predictions

PRINCIPAL INVESTIGATOR: Russ Schumacher

RESEARCH TEAM: Greg Herman

NOAA TECHNICAL CONTACT: Jim Nelson, Weather Prediction Center

NOAA RESEARCH TEAM: N/A

PROJECT OBJECTIVES:

--Using this forecast system, identify the ensemble membership that optimizes the skill and reliability of probabilistic forecasts of extreme local rainfall. Some of this research has already been conducted and is outlined in greater detail below. This support will allow for continued fine-tuning of this analysis for different models and regions of the US.

--Evaluate a prototype of this forecast system in the Flash Flood and Intense Rainfall (FFaIR) experiment and in an operational environment at the Weather Prediction Center (WPC). FFaIR allows for robust evaluation of a forecast system by forecasters and researchers in a realistic real-time environment. Based on this evaluation, the system will be improved and prepared for evaluation in WPC operations.

--Implement an operational version of this forecast system at WPC. Assuming the evaluations are successful, we will work with WPC to implement an operational version of the forecast system after incorporating relevant feedback and suggestions.

PROJECT ACCOMPLISHMENTS:

This project began in October 2016, so has been active for only 6 months at the time of this report. We have been making numerous advances with a particular aim of testing our developed probabilistic forecast systems during the FFaIR experiment in the summer of 2017. We have two working versions of this system at present: a relatively simple system that uses as much operational ensemble forecast output as available to generate probabilities of exceeding a defined recurrence interval, and a more sophisticated system that uses past model performance as analyzed by machine learning algorithms, which also generates probabilities of exceeding a defined recurrence interval. We expect to evaluate both of these systems during FFaIR in 2017.

Since the start of the project, we have had several meetings with our collaborators at the WPC, to discuss the methods for delivering the gridded forecasts in real time, and to discuss the evaluation procedure during FFaIR. We have also completed a draft operational transition plan and submitted that plan to NOAA for comment.

PROJECT TITLE: Improving Understanding and Prediction of Concurrent Tornadoes and Flash Floods with Numerical Models and VORTEX-SE Observations

PRINCIPAL INVESTIGATOR: Russ Schumacher

RESEARCH TEAM: Erik Nielsen, Sam Childs, Jen Henderson

NOAA TECHNICAL CONTAC: N/A

NOAA RESEARCH TEAM: N/A

PROJECT OBJECTIVES:

--Collect and analyze field observations of boundary-layer winds, thermodynamics, and precipitation structures in both tornado-only and TORFF situations to reveal important physical processes and environmental sensitivities. We propose to collect radiosonde observations in coordination with other VORTEX-SE groups, and to assist in the collection and analysis of data from the Colorado State University Dual-Pol C-band Doppler Radar (referred to as CSU-POL). Furthermore, we will analyze other available VORTEX-SE observations from radars, profiling instruments, rain gauges, and disdrometers, to better understand these processes, particularly in TORFF situations in the southeast.

--Use case-study and idealized numerical modeling experiments to quantify the influence of boundary-layer wind shear and thermodynamics on rainfall production in supercell storms and vortices embedded in convective lines. We hypothesize that very strong low-level wind shear in moist, but relatively stable, low-level conditions are optimal for producing extreme rainfall rates in addition to being favorable for tornadoes. We will continue to use operational observations and analyses, along with high-resolution numerical model experiments, to test this hypothesis and to reveal important sensitivities.

--Continue analysis of the NWS warning process during multi-hazard events by documenting the unique challenges in these events. Our current VORTEX-SE project has enabled the collection of a thorough and unique dataset on the warning process in multi-hazard situations, and further support will allow for the possibility of collecting additional observations and more detailed analysis of the existing dataset.

PROJECT ACCOMPLISHMENTS:

This project began in October 2016, and as such, we are about 6 months into the project. The main accomplishments thus far include beginning to run and analyze numerical model simulations, preparing for the field phase data collection of VORTEX-SE in spring 2017, and conducting surveys and interviews following from a couple tornadoes that occurred in late 2016/early 2017 in the southeast.

Erik Nielsen presented his preliminary results regarding tornado/flash flood (TORFF) events at the AMS annual meeting in January 2017, and received 2nd place student presentation awards for both his oral presentation and his poster presentation.

We are prepared to collect mobile sounding data during the VORTEX-SE field campaign from March-May 2017, and we will report on the results in future reports.

Jen Henderson traveled to the southeast in February 2017 in collaboration with NCAR scientists to conduct interviews following the tornadoes that struck in late January. Results from these interviews will also be reported in future reports.

Publications:

An Updated U.S. Geographic Distribution of Concurrent, Collocated Tornado and Flash Flood Events and Look at those Observed during the First Year of VORTEX-SE, 97th American Meteorological Society Annual Meeting, January 2017 (Erik Nielsen)

Observations of Extreme Short-Term Precipitation Associated with Supercells and Mesovortices, 97th American Meteorological Society Annual Meeting, January 2017 (Erik Nielsen)

PROJECT TITLE: Investigating the Underlying Mechanisms and Predictability of the MJO – NAM Linkage During Boreal Winter in the NMME Phase-2 Model Suite

PRINCIPAL INVESTIGATOR: Jason Furtado (University of Oklahoma), Elizabeth Barnes (CSU)

RESEARCH TEAM: Elizabeth Barnes (Co-PI; 1 month/year)

NOAA TECHNICAL CONTACT: N/A

NOAA RESEARCH TEAM: N/A

PROJECT OBJECTIVES:

1--Enhance our knowledge about the dynamical links between the MJO and the NAM by considering the modulating influence of the extratropical stratosphere

2--Evaluate these mechanisms of MJO-NH extratropical atmospheric teleconnections in the North American Multi-Model Ensemble Phase-2 (NMME-2) system

3--Connect and apply our findings and evaluations to predictions of atmospheric blocking and extreme weather events.

PROJECT ACCOMPLISHMENTS:

Work has begun by the PI (Jason Furtado) at the University of Oklahoma and his graduate student as well as at NOAA CPC. The entire project team participated in a telecon on Dec. 1, 2016 to outline steps forward, and discuss the best methods and data for evaluation. Co-PI Barnes will be visiting the University of Oklahoma in March.

PROJECT TITLE: Multi-disciplinary Investigation of Concurrent Tornadoes and Flash Floods in the Southeastern US

PRINCIPAL INVESTIGATOR: Russ Schumacher

RESEARCH TEAM: Erik Nielsen, Greg Herman, Jen Henderson, Sam Childs,

NOAA TECHNICAL CONTACT: N/A

NOAA RESEARCH TEAM (The equivalent of CIRA Research Team for NOAA Staff involved in the project and their affiliations): N/A

PROJECT OBJECTIVES:

As outlined in the original proposal, the specific objectives of this project are as follows:

--Investigate the detailed meteorological conditions in concurrent, co-located tornado and flash flood (TORFF) events in the southeastern US, including how they evolve in time, and how they differ from cases where only the individual hazards occur. Using readily available radar, precipitation, and reanalysis datasets, we will quantitatively identify the meteorological factors that commonly lead to TORFF events in the southeast, along with one or two detailed case studies of particularly destructive events.

--Investigate the NWS warning process during multi-hazard events, and document the unique challenges in these events. By conducting observational analysis and interviews with NWS forecasters in the southeast, we will examine the challenges they encounter in preparing for, identifying, and issuing warnings with enough lead time for appropriate societal response.

PROJECT ACCOMPLISHMENTS:

For this reporting period, the primary meteorological research has focused on three areas: (1) analyzing the meteorology of southeast TORFFs in an aggregate sense; (2) analyzing the observed TORFF that occurred on 31 March 2016 in southeast Arkansas during the VORTEX-SE field phase; and (3) conducting numerical simulations to understand the processes supporting concurrent heavy precipitation and strong low-level rotation. This work is being conducted by PI Russ Schumacher and graduate students Erik Nielsen and Greg Herman.

For (1), we have compiled a database of observed TORFF events in the southeast and the aggregate analysis, including standardized anomalies and composite analysis of meteorological fields, is very nearly complete. The results of this analysis were presented at the AMS Severe Local Storms conference in November 2016 and the AMS annual meeting in January 2017.

For (2), we have analyzed the one confirmed TORFF event that occurred during the VORTEX-SE observing period. The event occurred in Dermott, AR between 0400 and 0500 UTC on 31 March 2016. On that night, a tornado rated EF-1 passed through the town from southwest to northeast and led to one injury. Furthermore, two flash flood local storm reports (LSRs) were reported within 30 minutes of the tornado reports for widespread flooding across Dermott. Both the tornado track and flash flood LSRs fell within an overlapping tornado and flash flood warnings. We have conducted a case-study simulation of this event using WRF with initial conditions coming from a member of the NCAR ensemble (courtesy of Glen Romine). This simulation produced a reasonably accurate representation of the observed precipitation, and also showed strong updraft helicity and moderately heavy hourly rainfall near Dermott at the time when it was observed. The atmospheric profile from the simulation shows a stable boundary layer in the inflow region, but extremely strong low-level vertical wind shear.

For (3), in addition to the case-study simulation above, we are conducting idealized numerical simulations to investigate rainfall production in supercells or mesovortices embedded within larger convective systems. The simulations use thermodynamic and shear profiles that are representative of southeast TORFF cases. Results from (2) and (3) were presented at the AMS Severe Local Storms conference in November 2016.

For the social science research, Jen Henderson continues to analyze the observations and field notes collected at the forecast office, having spent 2.5 weeks total there during January, February, and April.

For this reporting period, the main focus has centered on (1) finishing follow-up interviews with Jackson staff; (2) transcribing interviews and audio from field notes; and (3) coding of materials.

For (1), phone interviews were conducted with three staff members at the Jackson office who were unavailable during the fieldwork in January-April; additional follow-up interviews were completed with two forecasters to calibrate initial results. For (2) all interviews have been transcribed and transcriptions of portions of the field work recordings will be completed by the end of November. For (3) coding has begun of current interviews and will be completed by early spring 2017. Analysis of field notes has begun and preliminary results were presented at NWA in Sept. 2016. Initial findings suggest that differences in how forecasters view threats of flash flooding and tornadoes are embedded in policies, consultation of national center outlooks, and office organization and staffing for warnings. For example, SPC outlooks helped overdetermined content of local office AFDs, which mentioned local tornado threats in Day 7. This created a commitment in the office to continuing heightened tornado threats for fear of send a mixed message to the public, even as threats of tornadoes began to diminish and flash flooding increased in the hours before storm initiation. Such differences may propagate throughout the warning system, in news media and in partner conversations, shaping how different publics react to these threats. Even terminology for these two threats suggests a privileging of risk for tornadoes, e.g. warning graphics include mention of "flash flood and severe" highlighting that one of these threats is more serious. This work was presented at the Severe Local Storms symposium at the AMS annual meeting in 2017.

Lastly, graduate student Sam Childs also joined the research team. He contributed to the project by analyzing large-scale conditions and trends associated with cool-season tornado outbreaks in the southeast US.

We expect to bring all of these tasks to completion by mid-2017.

Near-real-time TORFF monitoring website: http://schumacher.atmos.colostate.edu/weather/TORFF_rt/

Publications:

Numerous presentations were given at conferences on work resulting from this project. These are listed below, and three of the student presentations received awards (Sam Childs at the AMS Severe Local Storms conference, and both of Erik Nielsen's presentations at the AMS Annual Meeting)

Presentations:

Tornado and Flash Flood (TORFF) Warnings: Operational Challenges during Multiple Hazards (Invited Presentation), 97th American Meteorological Society Annual Meeting, January 2017 (Jen Henderson)

An Updated U.S. Geographic Distribution of Concurrent, Collocated Tornado and Flash Flood Events and Look at those Observed during the First Year of VORTEX-SE, 97th American Meteorological Society Annual Meeting, January 2017 (Erik Nielsen)

Observations of Extreme Short-Term Precipitation Associated with Supercells and Mesovortices, 97th American Meteorological Society Annual Meeting, January 2017 (Erik Nielsen)

"Meso-beta-scale vortices in heavily raining convective systems: symptom or cause of extreme precipitation? (or both?)" University at Albany/SUNY Department of Earth and Atmospheric Science Seminar, November 2016 (Russ Schumacher)

"Cold-season Tornadoes: Climatological, Meteorological, and Social Perspectives", 28th Conference on Severe Local Storms, American Meteorological Society, Portland, OR, November 2016 (Sam Childs)

"Predicting 'Double Impact' Concurrent and Collocated Tornadoes and Flash Floods", 28th Conference on Severe Local Storms, American Meteorological Society, Portland, OR, November 2016 (Greg Herman)

"A Closer Look at Concurrent, Collocated Tornado and Flash Flood Events Observed during the First Year of VORTEX-SE", 28th Conference on Severe Local Storms, American Meteorological Society, Portland, OR, November 2016 (Erik Nielsen)

"Extreme short-term precipitation from supercells and mesovortices: Insights from numerical simulations," 28th Conference on Severe Local Storms, American Meteorological Society, Portland, OR, November 2016 (Russ Schumacher)

"Observations of Extreme Short-term Precipitation Associated with Supercells and Mesovortices", 28th Conference on Severe Local Storms, American Meteorological Society, Portland, OR, November 2016 (Erik Nielsen)

"Tornado and Flash Flood (TORFF) Warnings: Operational Challenges during Multiple Hazards, 41st National Weather Association annual meeting, September 2016 (Jen Henderson)

"Meso-beta-scale vortices in heavily raining convective systems: symptom or cause of extreme precipitation? (or both?)" National Weather Center Colloquium, Norman, OK, April 2016 (Russ Schumacher)

Annual Progress Report

Observational constraints on the mechanisms that control size- and chemistry-resolved aerosol fluxes over a Colorado forest

Award Number: NA14OAR4310141
Principal Investigator: Dr. Delphine K. Farmer
Institution: Colorado State University, Fort Collins, CO 80523
Co-investigators: Dr. Chris Kummerow
Start Date: August 1, 2014
Period Covered: May 1, 2016 – March 15, 2017

I Project Statement

This project is focused on providing observational constraints on dry deposition of organic compounds in the gas and particle phase, and the extent to which forest-atmosphere exchange controls the fate of organic carbon in the atmosphere. The proposed work tackles the following questions:

1. Which chemical and physical components dominate the aerosol flux budget, and how do they vary seasonally?
2. How does dry deposition of accumulation mode aerosol over a temperate forest vary seasonally, and what is the impact of this sink on aerosol lifetime?
3. How important are the fluxes of semi-volatile organic compounds in controlling organic aerosol deposition?

II Accomplishments

Summary: Progress during the third year of research includes substantial advances in the analysis of flux measurements from five seasons at Manitou Experimental Forest. In particular, four papers are in progress and will be submitted by July 2017. These include: (A) a paper describing seasonal variability in organic acid fluxes at Manitou Experimental Forest (Fulgham et al.; to be submitted to Atmospheric Chemistry and Physics), (B) a paper describing total particle number fluxes at Manitou Experimental Forest (DeBolt et al.; to be submitted to Aerosol Science and Technology), (C) a paper describing wet deposition of carbon and nitrogen at the site (Riches et al.; to be submitted to Atmospheric Environment), and (D) the ecosystem sources and sinks of formic acid (Fulgham et al.; to be submitted to Atmospheric Chemistry and Physics). In addition, papers describing (E) size-resolved particle number fluxes and a new parameterization to describe aerosol dry deposition is in progress, and (F) the overall carbon balance of the Manitou Experimental Forest site are in progress, and will be submitted in the next year. We have requested a no-cost extension to support the final analysis, write-up and publication fees associated with these papers.

(A) *Seasonal cycles in organic acid fluxes over a ponderosa pine forest*
[Fulgham et al. To be submitted to Atmospheric Chemistry and Physics in Spring 2017]

This manuscript describes our measurements of eddy covariance fluxes of formic acid, butyric acid, methacrylic acid, and propanoic acid over Manitou Experimental Forest in summer 2015 and the four seasons of 2016. The manuscript includes descriptions of the measurement approach, analysis techniques, and method validation, including extensive spectral analysis of the time-of-flight chemical ionization mass spectrometry data. We find upward fluxes of formic and butyric acid in all seasons – though the magnitude of the fluxes are substantially greater in summer than in winter, consistent with a temperature dependence. These fluxes suggest ecosystem sources of these compounds to the atmosphere; wintertime fluxes are consistent with snow sources,

potentially from methanogenic bacteria. Butyric acid may be indicative of fungal activity. Methacrylic and propanoic acid emissions are limited to summer months.

(B) Total particle number fluxes over Manitou Experimental Forest
[DeBolt et al. To be submitted to *Aerosol Science and Technology*. Spring 2017]

This manuscript describes deposition of aerosol particles at Manitou Experimental Forest from measurements throughout 2016. Deposition fluxes, as determined by eddy covariance using an ultrahigh sensitivity aerosol spectrometry, follow aerosol number concentration. Aerosol concentrations and deposition fluxes are higher in the summer than spring and fall; winter time concentrations tend to be much smaller. We observe an increase in fluxes with friction velocity, a measure for turbulence; this relationship allows us to compare fluxes to studies in other locations, and contrast environments.

(C) Seasonal variability in wet deposition of organic carbon and nitrogen in the Rocky Mountains
[Riches et al. To be submitted to *Atmospheric Environment*. Summer 2017]

We use precipitation measurements collected from Manitou Experimental Forest to contribute to the limited literature on wet deposition as a loss process for organic carbon. We find that the concentration of organic carbon correlates to biogenic emissions and plant activity, indicating that wet deposition can be a substantial sink for biogenic carbon.

(D) Ecosystem sources of formic and butyric acid
[Fulgham et al. To be submitted to *Atmospheric Chemistry and Physics*]

This manuscript describes the ecosystem components that contribute to strong summertime upward fluxes of formic and butyric acid, including measurements from branch and soil chambers. We also compare the emissions to surface chemistry, using laboratory measurements of ozone and OH radicals reacting with various ecosystem surfaces, which we find can be a substantial source of these organic acids.

III Plan for Requested No-Cost Extension

In order to complete the analyses, we requested an extension for this grant. The start of the research was delayed due to timing of student hiring. While the field campaigns have been successfully completed, we request to use the remaining funds for student time for analysis and writing and publication costs to complete the additional papers. We propose to use the remaining funds over the next year to cover salary plus fringe and tuition for two graduate students (Ryan Fulgham and Holly DeBolt) for 10.0 months (two semesters each). These two students are currently finalizing data analysis and in the paper-writing process. We include conference travel for each student to attend one conference (e.g. the American Geophysical Union meeting in December 2017), and publication costs.

IV Presentations and Publications

D.K. Farmer. *“Tracking biogenic and anthropogenic emissions of organic carbon over forests and urban regions.* University of California Berkeley. Berkeley Atmospheric Sciences Center Seminar Series. Fall 2016. INVITED.

D.K. Farmer, S. R. Fulgham, H. DeBolt, P. Brophy, J. Ortega. Investigating organic carbon fluxes: Biosphere-atmosphere exchange of gas-phase organic compounds and particles over Manitou Experimental Forest. IGAC Meeting. Breckenridge, CO. 2016. Poster Presentation

S. R. Fulgham, P. Brophy, M. Link, J. Ortega, D.K. Farmer. Seasonal measurements of organic acid fluxes over a ponderosa pine forest. American Geophysical Union Fall Meeting. San Francisco, CA. 2016. Poster presentation

S.R. Fulgham, P. Brophy and D.K. Farmer. Large upward fluxes of organic acids measured by acetate ToF-CIMS. Gordon Research Conference on Biogenic Hydrocarbons in the Atmosphere. Girona, Spain. 2016. Poster Presentation.

S.R. Fulgham and D.K. Farmer. Eddy covariance flux measurements with HR-TOF-CIMS. ToF-CIMS User Meeting. Boulder, CO. 2016. Oral Presentation

PROJECT TITLE: Quantifying Stochastic Forcing at Convective Scales

PRINCIPAL INVESTIGATOR: David Randall, Professor, Department of Atmospheric Science

RESEARCH TEAM:

NOAA TECHNICAL CONTACT:

NOAA RESEARCH TEAM: Drs. Vijay Tallapragada and Shrinivas Moorthi, National Centers for Environmental Prediction

PROJECT OBJECTIVE:

The research is aimed at improving modeling capabilities at the Environmental Modeling Center (EMC) of the National Centers for Environmental Prediction (NCEP), with emphasis on the prediction of convective weather systems and the effects of such systems on broader-scale forecasts. Specifically, we will provide EMC with a modeling tool that can be used to generate initial conditions for ensemble members that differ partially or even exclusively through stochastic perturbations of the parameterized cloud systems. This is beneficial because of the potential importance of convectively excited perturbations generating spread among the ensemble members.

Although overall forecast skill has improved dramatically over the past few decades (Bauer, et al., 2015), precipitation, and especially convective precipitation, is still notoriously difficult to predict (e.g. Haiden et al., 2012). There can be many reasons for this, including various deficiencies of the parameterizations used in forecast models. The most fundamental reason, however, is that *a cloud system is chaotic* on the time-scale of even a one-day forecast, i.e., the evolution of cloud systems exhibit sensitive dependence on their initial conditions.

The role of chaos in limiting the predictability of the atmosphere has been recognized for many years (Lorenz, 1963). Ensemble forecasting was invented as a way to adapt to and even take advantage of atmospheric chaos. Ensemble forecasts are created by running multiple copies of a forecast model, each copy started from a unique initial condition (e.g., Kalnay, 2003). The initial conditions differ from each other only slightly, within the uncertainty of the observations. The differences among the initial conditions are often referred to as the initial “perturbations.” The perturbations reflect our uncertainties about the initial state of the atmosphere. Perturbations tend to grow through instabilities, such as baroclinic instability. For this reason, it is useful to initialize an ensemble of forecasts by using perturbations that arise from the instabilities (e.g., Toth and Kalnay, 1993, 1995).

Uncertainties about the initial state of the atmosphere can arise from many causes, including inaccurate measurements, inadequate sampling, and imperfect analyses. Because of inadequate sampling, the largest uncertainties in a model's initial conditions tend to occur on the smallest spatial scales that are included in the model. There is a second reason to expect large uncertainties on the smallest resolved scales, particularly in high-resolution forecast models: These are the scales that are closest to the convective scale, on which strong instabilities can occur. The chaotic nature of convection, mentioned above, arises in part from the simple fact that convection originates through an instability. A second key factor is nonlinearity: The powerful vertical fluxes of energy and momentum associated with convection can converge or diverge to affect larger scales. Instability and nonlinearity together are the key ingredients of chaos. Chaotic convection on scales that are not resolved in a model can or *should* stochastically perturb the resolved scales. For these reasons, *chaotic convection on unresolved scales is thought to be a very important source of perturbations affecting larger-scale weather, especially in convectively active regions of the atmosphere.*

PROJECT ACCOMPLISHMENTS: New Project. Report to NOAA not yet due.

A CPT for Improving Turbulence and Cloud Processes in the NCEP Global Models

Steven K. Krueger (Lead P.I.), Peter A. Bogenschutz (P.I.),
Shrinivas Moorthi (P.I.), Robert Pincus (P.I.), and David A. Randall (P.I.)

Year 3 Progress Report
Grant NA13OAR4310101

Results and Accomplishments

Our hypothesis is that the NCEP global models can be improved by installing an integrated, self-consistent description of turbulence, clouds, deep convection, and the interactions between clouds and radiative and microphysical processes. The goal of our CPT is to unify the representation of turbulence and SGS cloud processes and to unify the representation of subgrid-scale (SGS) deep convective precipitation and grid-scale precipitation as the horizontal resolution decreases.

We aim to improve the representation of small-scale phenomena by implementing a PDF-based SGS turbulence and cloudiness scheme that will replace the boundary layer turbulence scheme, the shallow convection scheme, and the cloud fraction schemes in the GFS and CFS. We intend to improve the treatment of deep convection by introducing a unified parameterization that scales continuously between the simulation of individual clouds when and where the grid spacing is sufficiently fine and the behavior of a conventional parameterization of deep convection when and where the grid spacing is coarse. We will endeavor to improve the representation of the interactions of clouds, radiation, and microphysics in the GFS/CFS by using the additional information provided by the PDF-based SGS cloud scheme. The team is evaluating the impacts of the model upgrades with metrics used by the NCEP short-range and seasonal forecast operations.

SGS Clouds and Turbulence

Incorporation into the NCEP global forecast model

A. Belochitski and S. Moorthi (both at NCEP) have completed the installation of our PDF-based SGS turbulence and clouds scheme called SHOC (Simplified Higher-Order Closure) into the NEMS as well as the operational versions of the GFS.

To evaluate SHOC, the operational GFS was run at T62 L64, with the original physics (control run) and with SHOC. A 5-day forecast was initialized on June 1, 2011. In the SHOC runs, the autoconversion of ice to snow coefficient was increased by an order of magnitude, for the reasons that will become evident.

Figure 1 shows that the high-level tropical cloud fraction is too large in the SHOC runs, despite the order of magnitude increase in autoconversion rate of ice to snow. The working hypothesis is that the excess tropical high level cloudiness is caused by SHOC diagnosing unrealistically narrow subgrid-scale PDF distributions of total cloud water where it is detrained from deep convection, as compared to those produced in high-resolution (100-m grid size) LES simulations of tropical deep convection.

We are exploring the sensitivities of SHOCs subgrid-scale PDF to the input parameters characteristic of upper tropospheric stratiform clouds that are produced by detrainment from tropical deep convection. In collaboration with Steve Krueger (University of Utah), we are investigating how to modify the subgrid PDF to be more suitable for this type of cloudiness.

Continued development and testing in other models

Developments and testing of the SHOC parameterization by P. Bogenschutz (NCAR) are ongoing, partially with support from the CPT. While the majority of the SHOC testing and developments were performed within a cloud resolving model (CRM) and the Super-Parameterized Community Atmosphere Model (SP-CAM), the CPT benefits from these efforts as a greater understanding of SHOC performance and code upgrades can be gained.

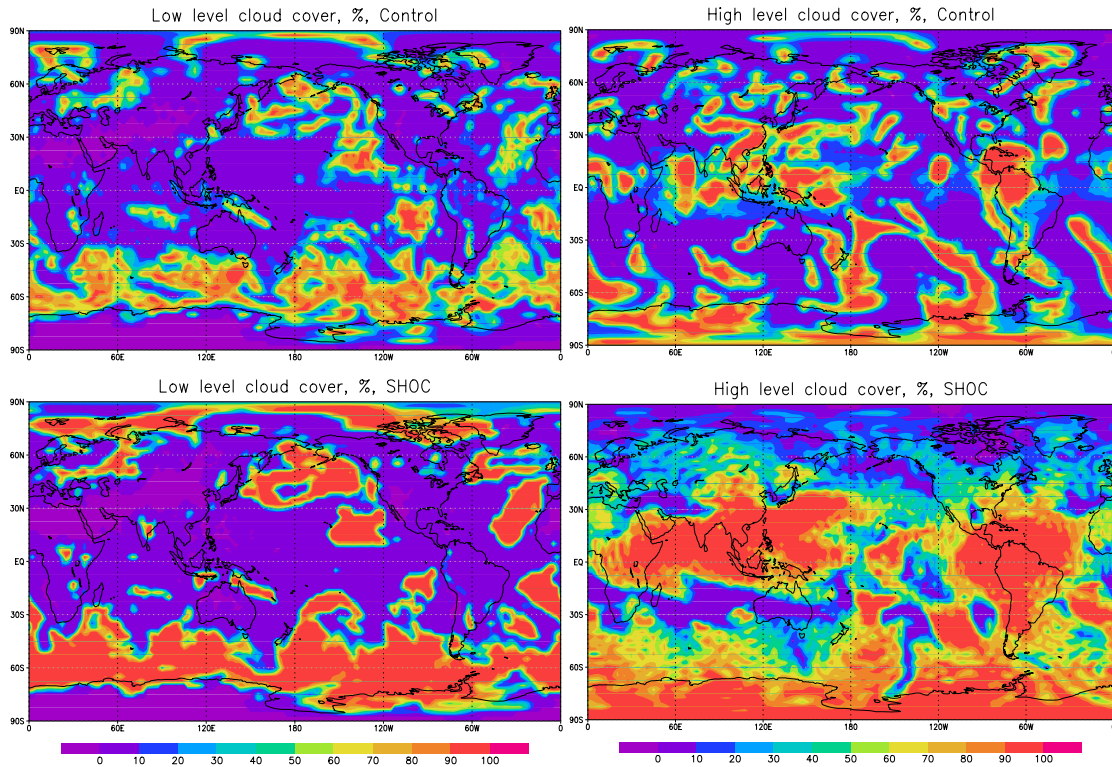

Figure 1: Low and high cloud amounts at 00Z June 6, 2011 for both control and SHOC forecasts using the NCEP GFS initialized on 00Z June 1, 2011 and run at T62 resolution.

Bogenschutz performed experiments that examined SP-CAM-SHOC coupled with a double moment microphysics scheme and sophisticated aerosol model. Not only does SP-CAM-SHOC produce superior climate and low cloud simulation compared to SP-CAM with a standard turbulence closure in this configuration, but it also simulates very reasonable aerosol indirect effects, which many GCMs tend to overestimate.

S. Krueger also continued to study the sensitivity of CRM simulations to subgrid-scale (SGS) turbulence closure, microphysics, and resolution. His group analyzed a set of radiative-convective equilibrium (RCE) simulation at two different sea surface temperatures (in order to assess sensitivity to climate change). The RCE simulation results are sensitive to horizontal grid size (in the range of 0.5 km to 16 km), SGS cloud and turbulence closure, and microphysics. The dependence on grid size in these explicit convection simulations supports the need for a unified cumulus parameterization scheme in which the updraft area fraction can be any value from 0 to 1. In contrast, the differences due to the SST change (between otherwise identical simulations) are mostly independent of horizontal grid size, SGS cloud and turbulence closure, and microphysics except for the shortwave cloud radiative effects.

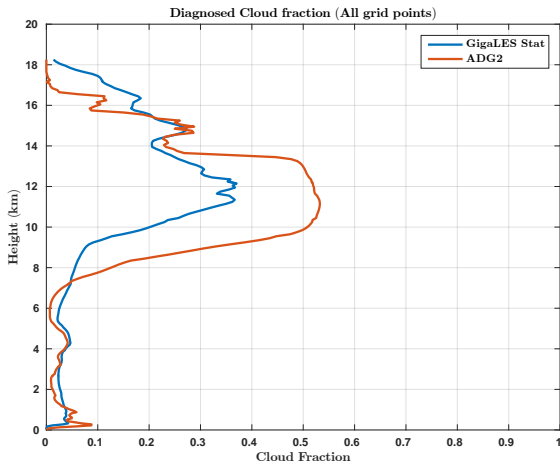

Figure 2: Cloud fraction profiles for all grid points in the Giga LES (blue) and diagnosed using the Analytic Double Gaussian PDF from input moments based on all grid points in the Giga LES (red).

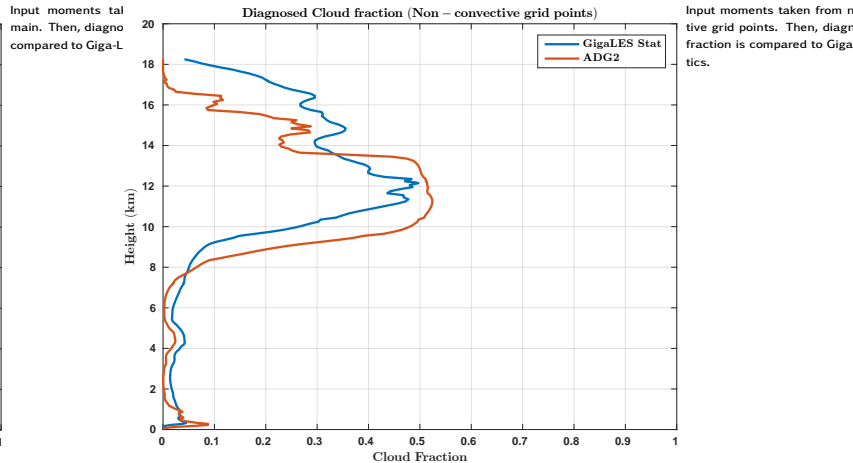

Figure 3: Cloud fraction profiles for the non-convective grid points in the Giga LES (blue) and diagnosed using the Analytic Double Gaussian PDF from input moments based on the non-convective grid points in the Giga LES (red).

Coupling to parameterized deep convection

S. Krueger (University of Utah) began to address the issue of coupling SHOC to parameterized deep convection. Most global models with conventional parameterizations treat stratiform and deep convective clouds separately. Because the fractional area covered by deep convective clouds in each grid column is assumed to be small, the direct radiative effects of these clouds is usually neglected. However, a deep convective updraft detrains water vapor and condensate at its non-buoyancy level, and in this way contributes to stratiform cloud formation, maintenance, and precipitation processes. With SHOC (or any assumed PDF approach), the SGS variability of stratiform cloud systems is represented in global models by a cloud fraction and a SGS distribution of radiative properties based on the assumed PDF. Microphysical process rates are usually based on the mean *in-cloud* mixing ratios of cloud condensate.

The fundamental problem in the presence of deep convection is how to determine the SGS PDF of total water when both stratiform and convective cloud processes are active. Bony and Emanuel (2001) used a PDF that represents both stratiform and convective cloud processes. They continuously adjust the shape of the PDF so that the in-cloud cloud condensate mixing ratio diagnosed from the PDF equals the sum of the cloud condensate produced by the stratiform and convective parameterizations. Tompkins (2002) added prognostic equations for the second and third moments of total water that include ad-hoc source terms for detrainment from the convection scheme. Klein et al. (2005) proposed physically based source terms to replace those of Tompkins. Bogenschutz et al. (2010) examined the capabilities of various types of joint PDFs for the entire cloud system to diagnose cloud fraction and non-precipitating cloud condensate given perfect input moments. For deep convective cloud systems, they found that the Analytic Double Gaussian 1 PDF (Larson et al. 2002)

performs the best at all levels for a horizontal grid size of 3.2 km. However, as the grid size exceeds about 50 km, the performance degrades quickly if there are errors in the SGS vertical fluxes of total water or liquid water static energy.

It is not clear from these studies whether one should try to determine the PDF for the entire cloud system or for just the non-convective (i.e., stratiform) portion. What PDF shape would be best is another issue that has not been resolved. For example, Bony and Emanuel used the generalized log-normal PDF of total water, but schemes designed for boundary layer clouds find that the double Gaussian PDF works best. What complexity of turbulence closure is required? SHOC diagnoses all second and third input moments other than the SGS turbulence kinetic energy. This approach makes it difficult to represent the effects of the sources and sinks due to detrainment on the higher-order moments.

S. Krueger has begun to explore these issues by using a high-resolution (100-m horizontal grid size) and large domain (200 km by 200 km) simulation of tropical deep convection (Khairoutdinov et al. 2010) called the Giga LES as a benchmark. The ten input moments required by the assumed PDF (in this case the Analytic Double Gaussian PDF), were diagnosed from the whole domain (all grid points) of the Giga LES and for the non-convective grid points.

Figure 2 displays the cloud fraction profiles for all grid points in the Giga LES and diagnosed using the Analytic Double Gaussian PDF from input moments based on all grid points in the Giga LES, while Figure 3 is the same except that the profiles are for the non-convective (stratiform) grid points in the Giga LES.

The results suggest that, even when using “perfect” input moments from both the convective and stratiform parts of the grid column, the Analytic Double Gaussian PDF shape overestimates the cloud fraction at the upper levels, but that when using input moments from the stratiform part alone, this PDF shape provides a good estimate of the (stratiform) cloud fraction profile. The success of this PDF shape for “perfect” input moments and a model grid size of 200 km is encouraging, and implies that the relatively poor results obtained with SHOC in the GFS are due to inaccurate input moments. Because SHOC estimates the required second and third moments using a simplified set of turbulence closures, we plan to replace some of these with more accurate closures in order to improve the estimates of upper level cloud fraction.

Cumulus Parameterization

One of the primary goals of our CPT has been to develop and implement a version of the Unified Parameterization (described below) with multiple updraft types. The first step towards this goal was to implement a convection parameterization with multiple updraft types, the Chikira-Sugiyama (CS) convection parameterization, into the GFS. This was accomplished during Year 2. The CS scheme was also implemented as an option in NEMS. In combination with SHOC, it has been tested at T2046L64 resolution. The 7-day forecast made from 00Z October 24, 2012, is shown in Figure 4. Unlike the operational version of GFS, it correctly predicts the westward track of Hurricane Sandy and its consequent landfall in the NY/NJ area.

The Unified Parameterization proposed by Arakawa et al. (2011) is designed to allow a model to simulate individual convective updrafts when and where the grid spacing is sufficiently fine, while acting as a conventional parameterization of deep convection when and

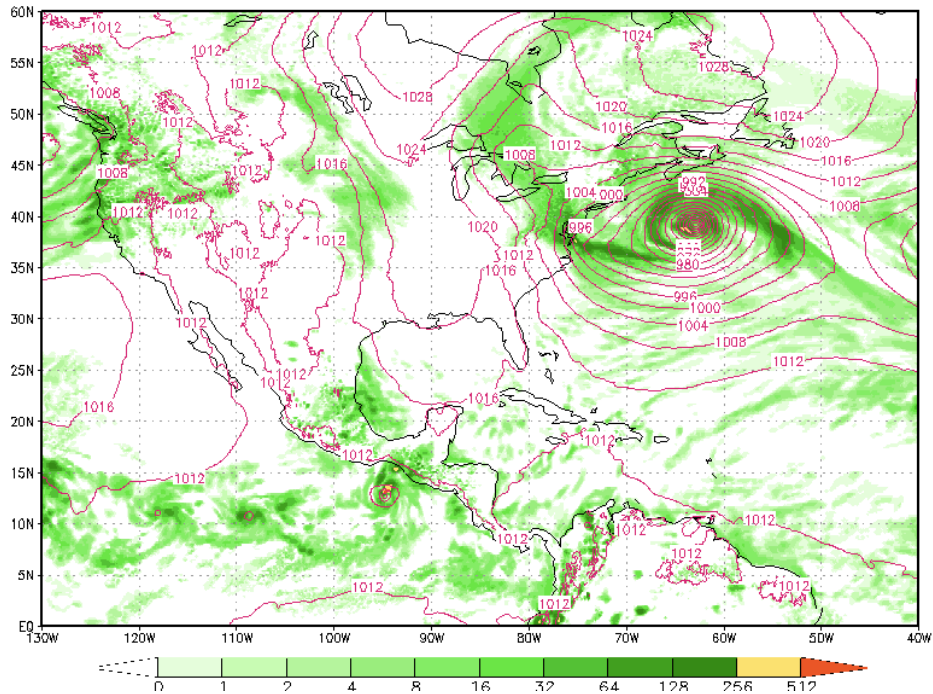

Figure 4: Sea level pressure and precipitation fields at 00Z of October 24, 2012 (forecast hour 177) from a T2046L64 NEMS/SHOC run that also includes a new Chikira-Sugiyama deep convection scheme. This version of NEMS correctly predicts the westward track of Hurricane Sandy.

where the grid spacing is coarse. Between these two limiting cases, the Unified Parameterization scales continuously, in all cases using the same equations and the same code.

The Unified Parameterization is derived by removing the assumption of small σ (convective updraft area fraction). When the grid spacing is coarse, small values of σ are expected, but when the grid spacing is fine it is possible for σ to approach 1. The closure for σ is thus a crucial aspect of the Unified Parameterization. However, the closure was originally developed for a convection parameterization with a single updraft type.

During Year 3, D. Randall, M. Chikira, and D. Dazlich (all at CSU), completed the development of a closure for σ for multiple updraft types and tested it in the GFS in a diagnostic mode. In addition, the microphysical tendencies from both the convective updrafts and the environment have been identified, and the relevant area-weightings are all computed and ready to use. Also, the CS parameterization has converted from its original form that used the compensating subsidence and detrainment form of the equations, which is only valid for small σ , to the flux divergence and source/sink form, which is valid even for large σ , and tested it in a two-month GFS run.

The next steps will be to (1) test forecasts with the current version and (2) add σ weighting and run additional climate simulations and test forecasts, including some with the highest possible horizontal resolution. A number of issues will then remain, including (1) determining if the scale awareness is working as intended, (2) combining with SHOC, (3) coupling with radiation, (4) developing robust diagnostics, and (5) deciding when to port to NGGPS.

Radiative Transfer and SGS Clouds

R. Pincus (U. Colorado) continued to work on the coupling of SHOC and the Arakawa-Wu unified convection to radiation within the GFS. The focus has been on finding efficient strategies for sampling the distribution of cloud condensate described by the SHOC PDF, especially on minimizing the number of random numbers required while maintaining accuracy and reasonably low instantaneous sampling noise. The issue arises because the distribution of cloud water or ice content is a byproduct of SHOCs distributions of liquid water potential temperature and total water content which are represented by a joint double Gaussian PDF. A single discrete sample of the joint PDF therefore requires sampling four independent Gaussians. Since each Gaussian sample requires roughly 2.25 univariate samples on average (via the Box-Muller transform) a direct approach increases the number of random numbers that must be drawn by a factor of roughly nine. Experience with other models suggests that drawing a single sample per grid cell, as is done now in the GFS, increases the cost of the radiation code by a few percent, so a direct approach is prohibitive. Possible acceleration approaches include sampling the linear correlation and/or reducing the dimensionality by linearizing the thermodynamics.

We are exploring the impact of these strategies off-line using global sets of PDF distribution parameters. (Because the PDFs produced by SHOC in the GFS remain unrealistically narrow we are using results from the CLUBB parameterization from the NCAR model via our collaborator Peter Bogenschutz.) Large numbers of samples of cloud condensate are drawn for each cell under the assumption of maximum-random overlap. Condensate is mapped to optical thickness assuming fixed drop sizes. The distribution of optical thickness is mapped to (scalar) shortwave and longwave cloud radiative effect using simple relationships. Calculations using direct (expensive) sampling are then compared to more approximate methods. Approximate sampling should remain unbiased, which is a useful check; we are also keeping track of the instantaneous sampling noise in surface and TOA radiative fluxes to ensure that our approximation dont become crude enough to impact model evolution.

References

- Arakawa, A., J. H. Jung, and C. M. Wu, 2011: Toward unification of the multiscale modeling of the atmosphere. *Atmos. Chem. Phys.*, **11**, 3731-3742.
- Bogenschutz, P. A., S. K. Krueger, and M. Khairoutdinov, 2010: Assumed Probability Density Functions for Shallow and Deep Convection. *J. Adv. Model. Earth Syst.*, **2**, 10, doi:10.3894/JAMES.2010.2.10.
- Bony, S. and K. A. Emanuel, 2001: A parameterization of the cloudiness associated with cumulus convection; evaluation using TOGA-COARE data. *J. Atmos. Sci.*, **58**, 3158-3183.
- Khairoutdinov, M. F., S. K. Krueger, C.-H. Moeng, P. Bogenschutz, and D. A. Randall, 2010: Large-eddy simulation of maritime deep tropical convection. *J. Adv. Model. Earth Syst.*, **1**, 15, doi:10.3894/JAMES.2009.1.15.
- Klein, S. A., R. Pincus, C. Hannay, and K.-M. Xu, 2005: How might a statistical cloud scheme be coupled to a mass-flux convection scheme? *J. Geophys. Res.*, **110**, D15S06, doi:10.1029/2004JD005017.
- Larson, V. E., J.-C. Golaz, and W. R. Cotton, 2002: Small-scale and mesoscale variability in cloudy boundary layers: Joint probability density functions. *J. Atmos. Sci.*, **59**, 3519-3539.
- Tompkins, A. M., 2002: A prognostic parameterization for the subgrid-scale variability of water vapor and clouds in large-scale models and its use to diagnose cloud cover. *J. Atmos. Sci.*, **59**, 1917-1942.

Highlights of Accomplishments

- SHOC code is now installed into the NEMS as well as the operational versions of the GFS.
- The high-level tropical cloud fraction is too large in the SHOC test runs with the GFS. However, the assumed PDF used in SHOC produces accurate cloud fraction profiles when provided with perfect input moments, which implies that some of the simplifications used in SHOC's turbulence closure models should be replaced.
- Completed the development of a closure for updraft fraction for multiple updraft types and tested it in the GFS in a diagnostic mode.
- Converted the Chikira-Sugiyama parameterization from its original form which is only valid for small updraft fraction to the flux divergence and source/sink form, which is valid even for large updraft fraction, and tested it in the GFS.
- In order to use the subgrid-scale PDF of cloud condensate diagnosed by SHOC for radiative transfer calculations, the focus has been on finding efficient strategies for sampling the distribution of cloud condensate.

Publications from the Project

(None)

PI Contact Information

Lead P.I.:

Steven K. Krueger, Professor
Department of Atmospheric Sciences
University of Utah
135 South 1460 East, Room 819
Salt Lake City, UT 84112-0110

steven.krueger@utah.edu

phone: (801) 581-3903

P.I.:

Dr. Shrinivas Moorthi, Research Meteorologist
Global Climate and Weather Modeling Branch
Environmental Modeling Center / NCEP
5830 University Research Court - (W/NP23)
College Park MD 20740

Shrinivas.Moorthi@noaa.gov

phone: (301) 683-3718

P.I.:

Dr. Robert Pincus, Research Scientist
CIRES
University of Colorado at Boulder
Box 216 UCB
Boulder, CO 80309-0216

robert.pincus@colorado.edu

phone: (917) 464-3569

P.I.:

David A. Randall, Professor
Department of Atmospheric Science
Colorado State University
1371 Campus Delivery
Fort Collins, Colorado 80523-1371

randall@atmos.colostate.edu
phone: (970) 491-8474

P.I.:

Peter A. Bogenschutz, Project Scientist
Climate and Global Dynamics
National Center for Atmospheric Research
P.O. Box 3000
Boulder, CO 80307-3000

bogensch@ucar.edu
phone: (303) 497-1341

Budget for Coming Year

The budgets for the coming year are unchanged from those revised before the awards were made in accord with NOAA's requests.

Investigator	Institution	Budget
Krueger	Univ of Utah	\$73,000
Moorthi	NCEP/NOAA	\$125,000
Pincus	ESRL/NOAA	\$80,000
Randall	CSU	\$70,000
Bogenschutz	NCAR	\$12,000

Future Work

Progress has been less rapid than originally proposed due to the reduction of Moorthi's (NCEP/NOAA) budget by more than \$130K, and the consequent reduction in postdocs at NCEP from two to one. The tasks originally proposed for Years 2 and 3 that have not been completed have been shifted to Year 4. However, due to the reduction in postdocs at NCEP, we are unlikely to complete all of the tasks now listed for Year 4.

- **Year 4**

Bogenschutz will continue to test SHOC performance on the deep convective regime and scale sensitivity and continue developments and improvements of SHOC parameterization. Krueger will improve the coupling of SHOC and the parameterized deep convection in the GFS, collaborate with Pincus on using information from SHOC in the radiative transfer model, and collaborate with Randall on using information from the unified cumulus parameterization in SHOC. Randall and Dazlich will run test forecasts with the new flux divergence and source/sink version of the Chikira-Sugiyama parameterization, then implement a multi-updraft version of the Unified Parameterization proposed by Arakawa and Wu and run additional climate simulations and test forecasts, including some with the highest possible horizontal resolution. Moorthi will help to port the GFS version to NEMS once development is completed on Gaia. Pincus will continue to work on the coupling of SHOC and the Arakawa-Wu unified convection to radiation within the GFS.

Continue to perform medium-range NWP forecasts with prescribed initial conditions (from the operational GDAS). Evaluate model performs and tune the physics if necessary. Start to perform AMIP-type climate tests¹ with prescribed (observed) SSTs. Depending on the results tune the model or modify the parameterizations. Since the planned changes touch all aspects of the physics including SGS turbulence, cloud-radiation-microphysics interaction, and unified convection, we expect extensive testing and fine tuning.

Carry out fully cycled GFS parallel experiments at lower resolution (such as T382), including both analysis and forecast steps. Using NCEP/EMC/GCWMB² standard verification package to assess performance of the updated model compared to the operational version at that resolution. Evaluation metrics include but are not limited to anomaly correlations, RMSE, precipitation skill scores, fits to surface and rawinsonde observations, hurricane track, etc. This procedure may need to be iterated to obtain optimal performance from the new physics.

If coupling to an ocean model is available,³ start testing with the coupled model to assess the impact of physics on long term coupled integration. If the results from any of the physics changes show promise for NWP, perform the cycled parallel test at the current (or future) operational resolution for possible operational implementation.

Examine impact of new physics on ENSO, MJO, ISO, monsoon variability, etc. Perform coupled model runs in the seasonal forecast mode: i.e., several years (~ 5 years) of nine-month retrospective forecasts from operational initial states starting from different seasons to assess the impact of the new coupled model on seasonal forecasting. Depending on the results, EMC may select all or parts of the physics upgrade to be considered for future CFS implementation. Likewise, we will again parallel test all or parts of physics upgrade (incorporated in the NEMS-based global model) in fully cycled mode at the anticipated resolution for future global model and make it available for operational implementation.

¹An AMIP-type climate test is a year-long forecast with observed boundary conditions of SST, snow, and sea ice fields to help identify if the updated physics has some climate bias.

²Global Climate and Weather Modeling Branch

³The current GFS is already coupled to MOM4 (GFDL's Modular Ocean Model, v. 4). However, the new GFS in the NEMS (NOAA Environmental Modeling System) infrastructure is yet to be coupled, but will be coupled to MOM5 (Modular Ocean Model, v. 5) and HYCOM (HYbrid Coordinate Ocean Model). CPC is already running the current GFS coupled to MOM4 as preliminary step toward future CFSV3.

PROJECT TITLE: Towards Assimilation of Satellite, Aircraft, and Other Upper-Air CO₂ Data into CarbonTracker

PRINCIPAL INVESTIGATOR: David F. Baker

CIRA RESEARCH TEAM: Andrew Schuh, David F. Baker

NOAA RESEARCH TEAM: Andrew Jacobson, CIRES/University of Colorado

NOAA TECHNICAL CONTACT: Pieter Tans, ESRL/Global Modeling Division

NOAA AWARD NUMBER: NA13OAR4310077

CarbonTracker is a data assimilation system that estimates sources and sinks of carbon dioxide from in situ atmospheric CO₂ measurements: <https://www.esrl.noaa.gov/gmd/ccgg/carbontracker/> It is one of the main sources, world-wide, for CO₂ flux estimates and optimized atmospheric CO₂ concentration fields. This project seeks to modify CarbonTracker so that it can assimilate CO₂ measurements taken in the middle and upper troposphere, for example from aircraft profiles, from satellites such as GOSAT and OCO-2, and from the surface-based sun-viewing spectrometers of the Total Carbon Column Observing Network (TCCON), in addition to the mainly surface-located in situ data currently used.

CarbonTracker currently uses a short assimilation "window" of 5 weeks, meaning that signals seen aloft in the CO₂ mixing ratios are attributed to fluxes occurring at the surface within the 5 preceding weeks. However, because signals in the upper portions of the atmospheric column are often due to fluxes occurring at the surface many months, or even years earlier, the system mis-attributes occurring far away to local fluxes emitted recently. Over the past year, CIRA PI-Baker has worked with NOAA PI Andrew Jacobson performing experiments in which the CarbonTracker assimilation window was lengthened to spans as long as 6 months, to assess the magnitude of the flux errors associated with the current 5-week window. These experiments have shown that the current version of CarbonTracker mis-allocates the global zonally-integrated CO₂ flux between the tropics and the extra-tropical NH: when the assimilation window is lengthened, CarbonTracker places about 0.3 PgC/yr more carbon outgassing in the tropics, balanced by 0.3 PgC/yr more carbon uptake in the northern regions. The magnitude of this error is significant for interpreting the annual budget of CO₂ and the processes that drive carbon sources and sinks: correcting this problem will increase the reliability of CarbonTracker when used in climate studies.

The corrected, longer-window version of CarbonTracker has been used over the past year to assimilate vertical profiles of CO₂ from NOAA aircraft, and is now being tested assimilating column CO₂ measurements from the OCO-2 satellite. Assimilating the aircraft data resulted in shifts in the latitudinal CO₂ distribution that were nearly as large as those due to lengthening the assimilation window. We are interested to see whether the satellite CO₂ measurements, with their more extensive coverage, result in similar or even larger shifts.

Errors in advection and vertical mixing in the atmospheric transport mode used in CarbonTracker, TM5, can lead to gross errors in the inverted CO₂ fluxes. To help assess such errors, Andrew Schuh from CIRA has been working on running CarbonTracker with the GEOS-Chem transport model in place of TM5. Over the past year, this code development effort has paid off, and the GEOS-Chem should be added to the suite of CarbonTracker cases used in compiling the official summary product distributed to the public.

OAR Office of Weather and Air Quality (OWAQ)
Joint Hurricane Testbed

Award Number: NA13OAR4590190

Upgrades to the Operational Monte Carlo Wind Speed Probability Program

Andrea Schumacher, Research Associate
CIRA/Colorado State University
andrea.schumacher@colostate.edu
970-491-8057

Submitted 23 November 2016

Linda Loing
Office of Sponsored Programs
Linda.Loing@colostate.edu
970-491-6586

Colorado State University
200 W. Lake Street
Fort Collins, CO 80521-4593

Award Grant Period: 09/01/2013 - 08/31/2016

Reporting Period End Date: 08/31/2016

Report frequency: Semi-annual

Final Annual Report? Yes

1. ACCOMPLISHMENTS

This project sought to complete a number of upgrades to the current Monte Carlo wind speed probability model (hereafter MC model), many of which are based on NHC feedback over the past few hurricane seasons. Three improvements to the MC model algorithm itself were proposed, including 1) replacing the linear forecast interpolation scheme with a more precise spline fit scheme, 2) applying a bias correction to the model track error statistics to provide consistency between NHC's uncertainty products, and 3) applying a bias correction to the radii-CLIPER used by the MC model to improve the accuracy of the wind speed probabilities for exceptionally small or large tropical cyclones. Three additions/enhancements were also proposed, which included 4) estimates of the arrival and departure times of 34/50/64-kt winds, 5) an integrated Goerss Predicted Consensus Error (GPCE) parameter, and 6) wind speed probabilities to 7 days. Finally, the error statistic generation code and scripts were consolidated to simplify annual product updates.

Note that this project was extended past its original completion date of 31 August 2016 (at no additional cost), and hence no major milestones had been proposed during this period. This extension was granted in order to continue providing these experimental products in real-time to NHC forecasters via the RAMMB/CIRA TC Realtime website at http://rammb.cira.colostate.edu/tc_realtime and to provide TSB with updated official forecast error statistics needed to perform the annual update of the operational NHC Wind Speed Probabilities product. All tasks planned for this reporting period were completed (see table below).

Proposed tasks	Planned	Actuals
Real-time experimental product demonstrations (for upgrades 1, 2, 3, 5)	Continue generating experimental wind speed probabilities demonstrating the above mentioned upgrades in real time	Continued generating experimental wind speed probabilities demonstrating the above mentioned upgrades in real time on the RAMMB TC Realtime webpage
Update error statistics for operational NHC Wind Speed Probability product for the 2016 season	Run development code to update error statistics for the operational WSP product, deliver to TSB in time to implement for 2016 season.	Updated error statistics for the 2016 operational Wind Speed Probability product using available final best tracks (2010-2014) and provided to TSB in March 2016.

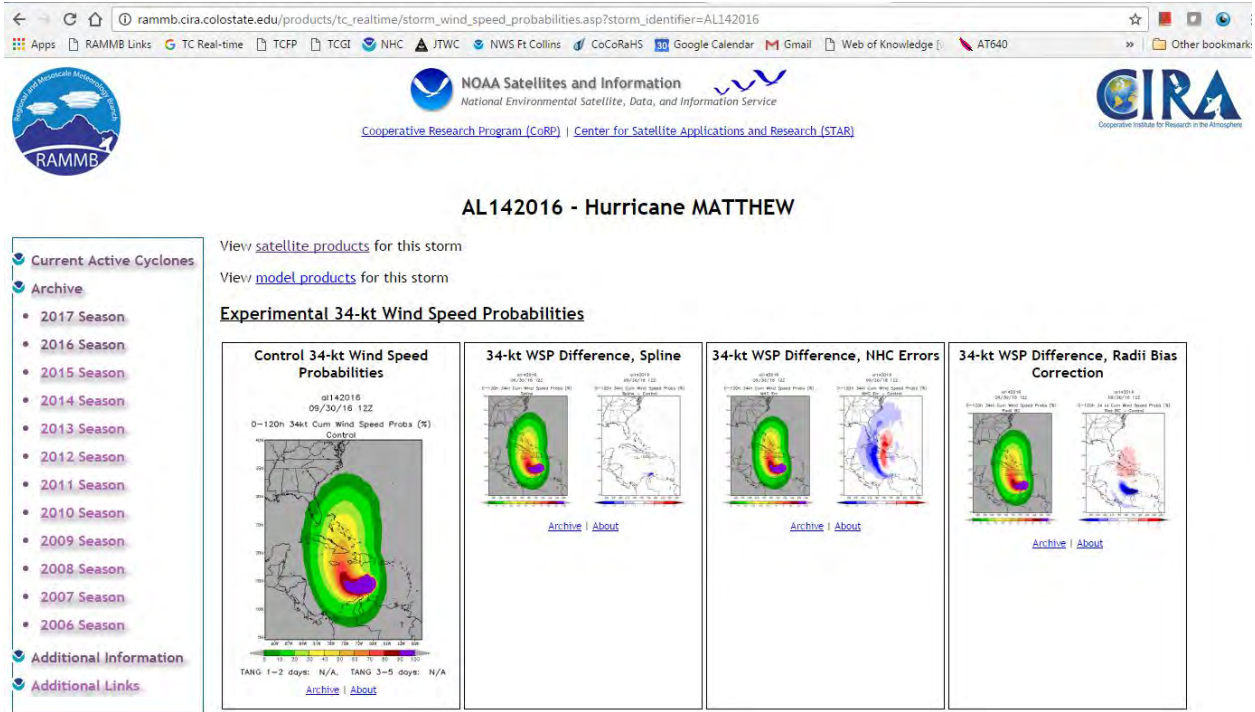

Figure 1: Real-time experimental product demonstration website (example of Hurricane Matthew 34-kt wind speed probabilities for 30 Sep 2016).

All proposed tasks for this period were completed on schedule (see table below).

Proposed tasks	Percent Completed	Due Date
Real-time experimental product demonstrations (for upgrades 1, 2, 3, 5)	100%	31 August 2016 (ongoing until operational implementation is complete)
Update error statistics for operational NHC Wind Speed Probability product for the 2016 season	100%	15 March 2016

2. PRODUCTS

This project resulted in the development of 6 new products (see table below). Products 1-3 are modified versions of the existing MC model while products 4-5 are new capabilities derived from the existing MC model.

Proposed products	Planned	Actuals
1. Algorithm improvement: spline interpolation	Continue real-time display of this update during this period.	Continued real-time display of this update during this period. Coordinated with TSB on plans for operational implementation for 2017 season.
2. Algorithm improvement: match NHC error statistics	Continue real-time display of this update during this period.	Continued real-time display of this update during this period.
3. Algorithm improvement: apply radii bias correction	Continue real-time display of this update during this period.	Continued real-time display of this update during this period. Coordinated with TSB on plans for operational implementation for 2017 season.
4. Algorithm addition: estimates of time of arrival and departure of winds	None.	Coordinated with TSB on plans for operational implementation for 2017 season.
5. Algorithm addition: integrated GPCE parameter	Continue real-time display of this update during this period.	Continued real-time display of this update during this period. Coordinated with TSB on plans for operational implementation for 2017 season.
6. Algorithm addition: wind speed probabilities for 6 and 7 day forecasts	None.	None.

3. PARTICIPANTS & OTHER COLLABORATING ORGANIZATIONS

Principal Investigator:

Andrea Schumacher, CIRA/CSU, Research Associate

Collaborators:

Robert DeMaria, CIRA/CSU, Research Associate

Mark DeMaria, NOAA/NWS/NHC/TSB

National Hurricane Center Points of Contact:

Dan Brown, NOAA/NWS/NHC

Michael Brennan, NOAA/NWS/NHC

Craig Mattocks, NOAA/NWS/NHC/TSB

Dave Roberts, NOAA/NWS/NHC

4. IMPACT

This project sought to complete a number of upgrades to the current MC model, many of which are based on NHC feedback over the past few hurricane seasons. The impacts of each proposed upgrade are listed in the table below.

Product upgrade	Impact(s)
1. Algorithm improvement: spline interpolation	The impact of using spline versus linear interpolation on basin-wide Brier scores and reliability was negligible, yet realization tracks generated with this upgrade appear smoother and more realistic. This will improve the performance of the MC model for cases of recurving tropical cyclones. Generating smoother realization tracks also lays the foundation for potential future applications that may be sensitive to small-scale track variations (e.g., storm surge modeling)
2. Algorithm improvement: match NHC error statistics	The impact of this upgrade on basin-wide Brier scores and reliability was mixed. However, this correction allows for a potential future benefit would be to enable to ability to obtain the cone of uncertainty directly from the MC model. The advantage to obtaining the cone in this manner is that its size would increase and decrease with forecast confidence obtained from the GPCE parameter.
3. Algorithm improvement: apply radii bias correction	This correction made a significant improvement in the appearance of the wind speed probabilities for extremely large and small cases (e.g., Sandy) and improved Brier scores in both basins for 34-kt and 50-kt wind speed probabilities.
4. Algorithm addition: estimates of time of arrival and departure of winds	This enhancement provides estimated arrival and departure times of 34-, 50-, and 64-kt winds that can be customized based on a user's risk tolerance. This is extremely valuable information for emergency managers to have when deciding on the timing and scope of preparations for landfalling tropical cyclone.
5. Algorithm addition: integrated GPCE parameter	Provides forecasters with a condensed estimate of situation-specific track forecast uncertainty that they can use to help determine what uncertainty messages they need to convey to the emergency managers and the public.
6. Algorithm addition: wind speed probabilities for 6 and 7 day forecasts	Wind speed probabilities were not found to be skillful beyond 5 days (at this time, with the limited sample of official >5day forecast currently available).

5. CHANGES/PROBLEMS

No changes or problems have been encountered with this project.

6. SPECIAL REPORTING REQUIREMENTS

Assessments of each upgrade's readiness level at the start of the project and now are listed in the table below.

Product upgrade	Starting Readiness Level	Current Readiness Level
1. Algorithm improvement: spline interpolation	RL 3	RL7
2. Algorithm improvement: match NHC error statistics	RL 3	RL6
3. Algorithm improvement: apply radii bias correction	RL 3	RL6
4. Algorithm addition: estimates of time of arrival and departure of winds	RL 3	RL6
5. Algorithm addition: integrated GPCE parameter	RL 2	RL6
6. Algorithm addition: wind speed probabilities for 6 and 7 day forecasts	RL 2	RL6

7. BUDGETARY INFORMATION

This project is on budget. All funds have been spent as of the end of this reporting period (31 August 2016).

8. PROJECT OUTCOMES

On 19 July 2016, the final decisions regarding operational implementation of these upgrades were received. Upgrades #1, 3, 4, and 5 were accepted, upgrade #2 was deferred, and upgrade #6 was not accepted. PI Schumacher met with TSB staff in August 2016 to discuss plans for implementing the accepted changes. All parties agreed to wait until after the end of the 2016 Atlantic hurricane season to begin that work.

This is final report for this project, but PI Schumacher will continue to work with TSB staff to implement product upgrades prior to the 2017 Atlantic hurricane season. The PI is expected to travel to NHC in February 2017 to, in part, assist with the implementation of these updates.

Project Title: Use of the Ocean-Land-Atmosphere Model (OLAM) with Cloud System-Resolving Refined Local Mesh to Study MJO Initiation

Project Number: NA13OAR4310163

PIs: Eric D. Maloney and William Cotton (Colorado State University) and Robert Walko (University of Miami)

Report Type: Year 4 Report

Results and Accomplishments

The following sections discuss publications and results from the project during 2016-2017. Publications from prior years will not be discussed. All publications resulting from this project are listed at the end of this report.

Applying weak temperature gradient moistening diagnostics to understand MJO dynamics in a superparameterized climate model (Wolding et al. 2016)

Decade-long runs of the NCAR CESM are conducted to examine the initiation and maintenance mechanisms associated with the MJO. In particular, the moisture budget diagnostics of Wolding and Maloney (2015b) that take advantage of the weak temperature gradient nature of the tropical atmosphere are used to understand moistening processes. The collective effects of convection can influence large-scale circulations that, in turn, act to organize convective activity. Such scale interactions may play an important role in moisture-convection feedbacks thought to be important to both convective aggregation and the MJO, yet such interactions are not fully understood. New diagnostics based on tropical weak temperature gradient (WTG) theory have begun to make this problem more tractable, and are leveraged in this study to analyze the relationship between various apparent heating processes and large-scale vertical moisture advection in SP-CESM.

WTG theory provides a framework for accurately diagnosing intraseasonal variations in large-scale vertical motion from apparent heating, allowing large-scale vertical moisture advection to be decomposed into contributions from microphysical processes, sub-grid scale eddy fluxes, and radiative heating. This decomposition is used to show that the MJO is a radiative-driven instability damped by horizontal advection, consistent with the findings of previous studies. **Figure 1** shows the a) MJO growth rate explained by various processes and b) the contribution of various processes to MJO propagation. **Figure 1a** (columns C and E) verifies the importance of radiation for destabilization and horizontal advection as the damping mechanism. Periods of low and high intraseasonal moisture variance (i.e. low and high aggregation) are compared, and it is found that the evolution of the vertical structure of apparent heating does not cause the radiative driven instability to become “self limiting” in the absence of horizontal advective damping. Finally, a diagnostic approach to scale analysis of tropical dynamics is used to investigate how the governing dynamics of various phenomena differ throughout wavenumber-frequency space. Findings support previous studies that suggest the governing dynamics of the MJO differ from those of strongly divergent convectively coupled equatorial waves. A paper describing these results is published in *the Journal of Advances in Modeling Earth Sciences*

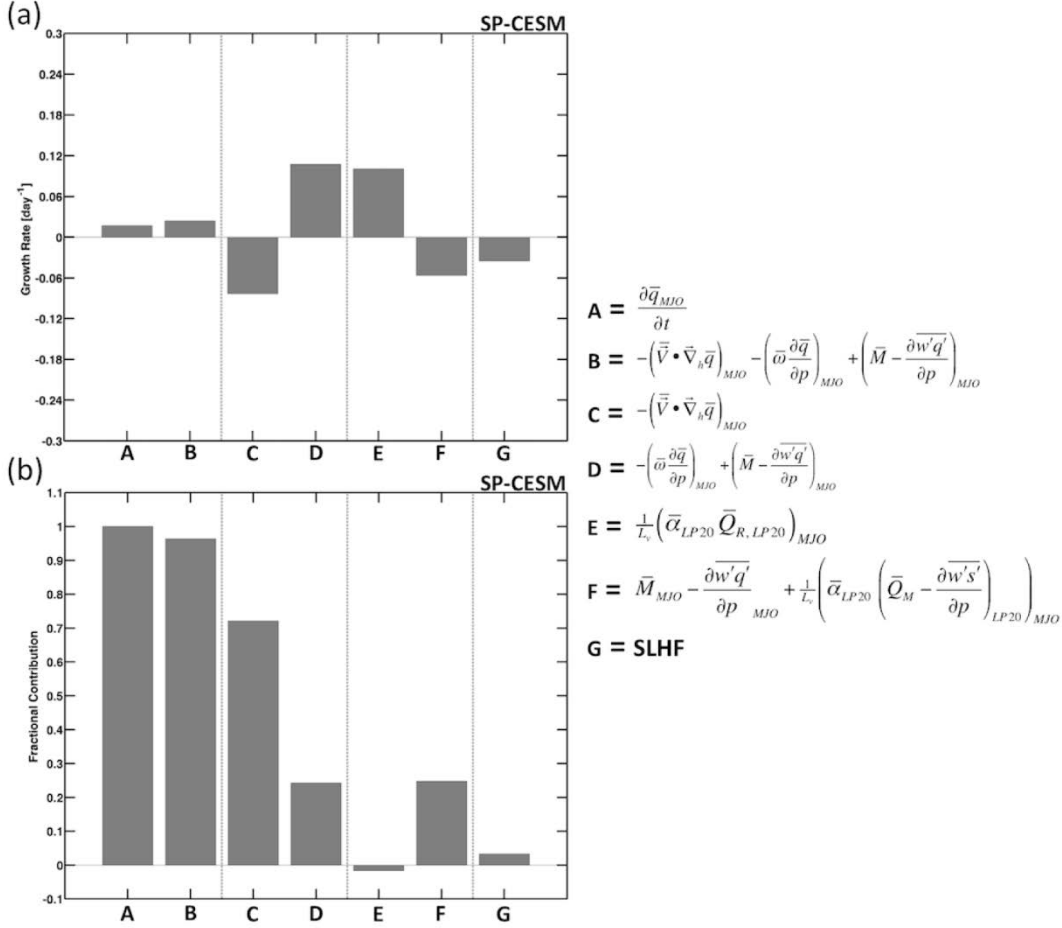

Figure 1. Vertically integrated contributions various budget terms make to the (a) column moisture variance growth rate and (b) column moisture tendency in SP-CESM. The area-weighted integral has been taken from 10.5N-14.5S; 60E-180E, and averaged from day -30 to day +30 for each of the 19 independent winter MJO events composited.

Climate change and the Madden-Julian Oscillation: A vertically resolved weak temperature gradient analysis (Wolding et al. 2017)

WTG balance is used to examine how changes in the moist thermodynamic structure of the tropics affect the MJO in two simulations of the Superparameterized Community Earth System Model (SP-CESM), one at preindustrial (PI) levels of math formula and one where math formula levels have been quadrupled (4×CO₂). While MJO convective variability increases considerably in the 4×CO₂ simulation, the dynamical response to this convective variability decreases (**Figure 2**). Increased MJO convective variability is shown to be a robust response to the steepening vertical moisture gradient, consistent with the findings of previous studies. The steepened vertical moisture gradient allows MJO convective heating to drive stronger variations in large-scale vertical moisture advection, supporting destabilization of the MJO. The decreased dynamical response to MJO convective variability is shown to be a consequence of increased static stability, which allows weaker variations in large-scale vertical velocity to produce sufficient adiabatic cooling to balance variations in MJO convective heating. This weakened

dynamical response results in a considerable reduction of the MJO's ability to influence the extratropics, which is closely tied to the strength of its associated divergence. A composite lifecycle of the MJO was used to show that northern hemisphere extratropical 525 hPa geopotential height anomalies decreased by 27% in the 4×CO₂ simulation, despite a 22% increase in tropical convective heating associated with the MJO. Results of this study suggest that while MJO convective variability may increase in a warming climate, the MJO's role in “bridging weather and climate” in the extratropics may not. A paper describing these results is published in *the Journal of Advances in Modeling Earth Sciences*

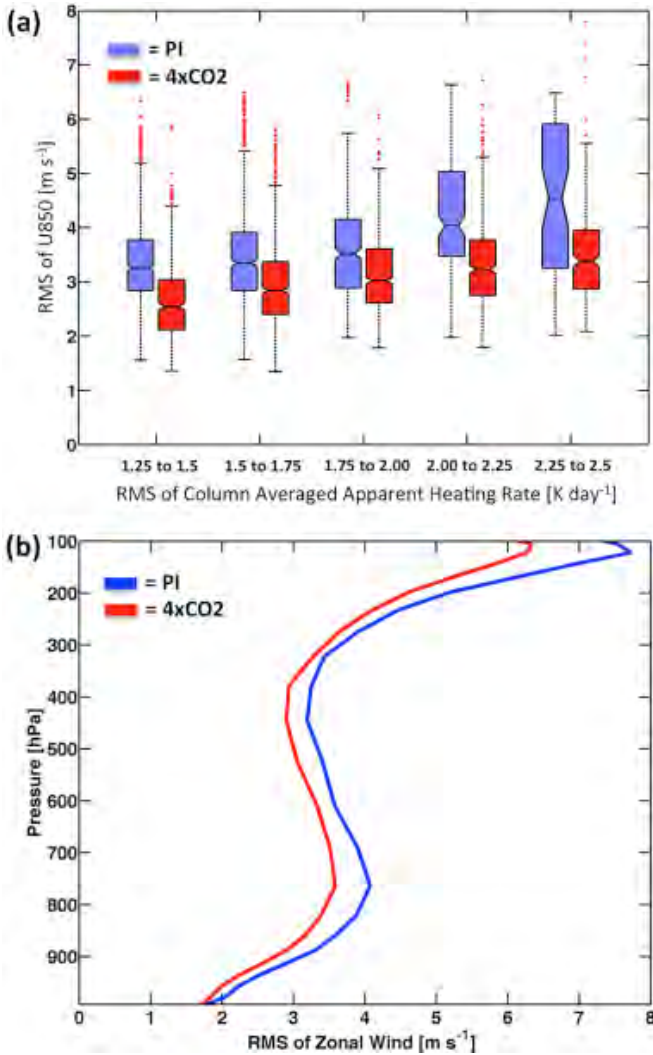

Figure 2. (a) Box and whisker plots of the root mean square (RMS) of 20–100 day band-pass filtered 850 hPa zonal wind for the domain 10N-10S, 60E-180E binned by the RMS of 20–100 day band-pass filtered column-averaged apparent heating rate over the same domain, for the PI (blue) and 4×CO₂ (red) simulations. Medians differ with 95% statistical significance if their notched intervals do not overlap. (b) Vertical profile of the RMS 20–100 day band-pass filtered zonal wind for the 1.75–2.00 K/day bin in Figure 2a.

Understanding MJO initiation and model bias for hindcast DYNAMO events in OLAM (Maloney et al. 2017)

We have continued to examine MJO behavior in hindcast experiments with OLAM during the DYNAMO period. We settled on a configuration that telescopes to 2.4 km inner mesh over the DYNAMO array region. This domain is shown in **Figure 3**. The WTG diagnostics of Wolding

and Maloney (2015b) have been employed to diagnose MJO behavior in the model. **Figure 4** shows the propagation of precipitation anomalies during the November 2011 MJO event in TRMM (left), a free version of OLAM initialized in early November (center), and a second run in which 2-hour relaxation timescale nudging is only applied to the moisture field (right). Clearly the free run of OLAM in this configuration has trouble with the amplitude and propagation direction of intraseasonal precipitation anomalies. By only nudging moisture, the observed propagation pattern of MJO precipitation is recovered, supporting the hypothesis that realistic simulation of the processes controlling the moisture field is key for producing a realistic MJO in models. Nudging tendencies suggest that MJO convection is too strong of a drying mechanism in OLAM that weakens significant moisture anomalies once they are formed. The diagnostic method of Wolding and Maloney (2015b) is used to verify this hypothesis.

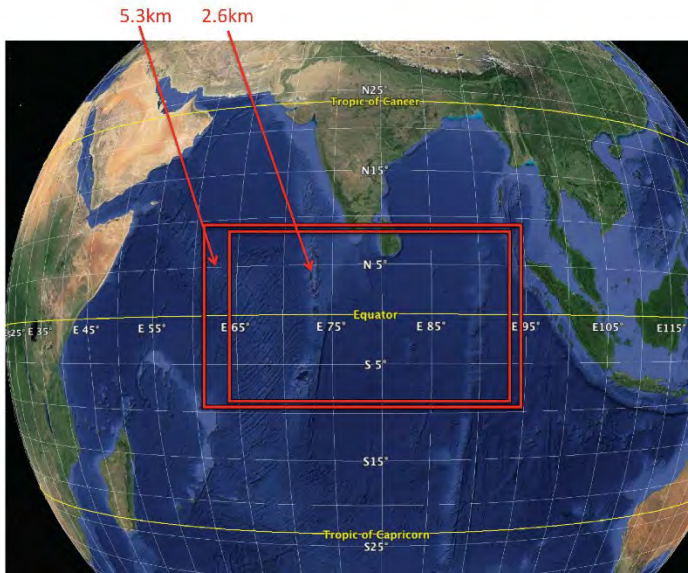

Figure 3. Map of the inner domain used in the OLAM simulation of the November 2011 MJO event.

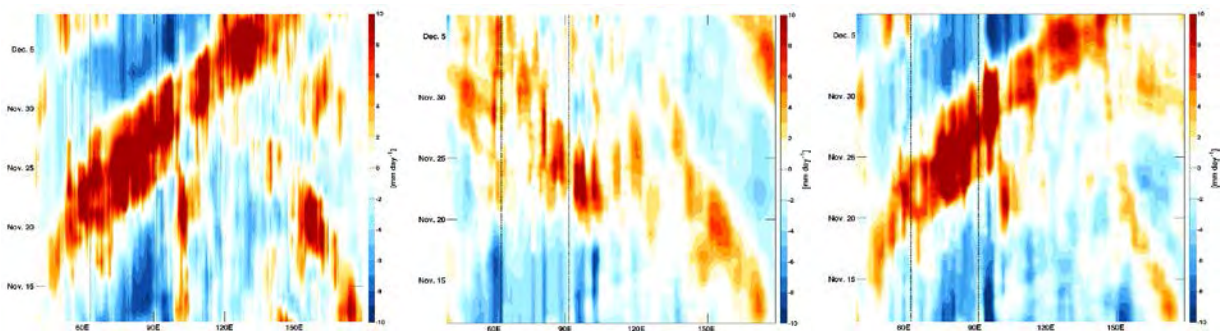

Figure 4. Precipitation anomalies for the November 2011 DYNAMO MJO event in a) TRMM, b) an un-nudged OLAM simulation, and c) the moisture-nudged OLAM simulation.

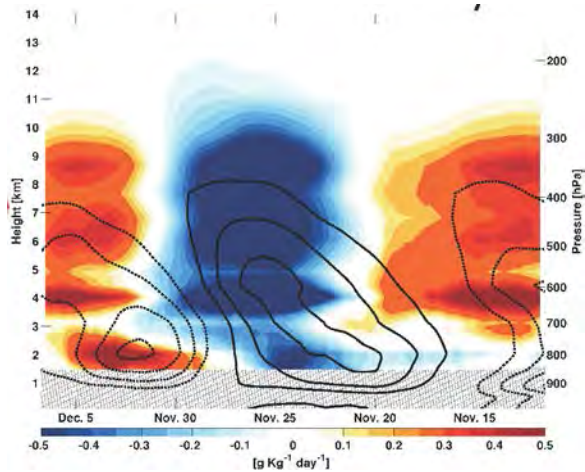

Figure 5. Net effect of convection on the anomalous moisture budget in OLAM in the moisture-nudged run (colors), and OLAM moisture anomalies (contours) during the November 2011 MJO event.

Figure 5 shows the net effect of convection on the MJO moisture budget in the OLAM nudged run (induced vertical advection plus condensational drying), indicating that the actions of convection create an extremely strong drying during the phase of the MJO when moisture and convection is enhanced. This strong drying by convection is overcome by the moisture-nudging tendency in the model to produce a realistic moisture evolution and resulting realistic MJO. We interpret this result as being associated with convection in the OLAM model that is too top-heavy when the MJO is active in the model. We are currently exploring whether higher model grid spacing (e.g. 1 km) in the refined mesh region may allow a more realistic simulation of convective entrainment that leads to more realistic vertical structure of convection. Modifications to the boundary layer treatment and configuration of the inner fine mesh and proximity to the parameterized convection region are also being examined. A manuscript is being generated detailing the OLAM runs and the application of moisture budget diagnostics to these runs (Maloney et al. 2017a). We have requested a no-cost extension into Year 4 to wrap-up this piece of work.

The importance of air-sea interaction for MJO Initiation in a coupled GCM (DeMott et al. 2017b).

We have investigated the impact of SST-driven boundary layer convergence to MJO initiation in a coupled GCM. The impact of ocean coupling on MJO dynamics is investigated in the superparameterized NCAR Community Earth System System Model (SPCESM), a model that produces realistic eastward propagating MJO variability in the tropics. The bulk boundary layer model of Back and Bretherton (2009) is first used to diagnose SST-driven convergence anomalies associated with composite SPCCSM MJO SST anomalies. **Figure 6** shows SST anomalies and associated surface convergence anomalies from two different phases of the SPCCSM MJO (these phases can be considered about 15 days apart in time). The SST anomalies drive surface convergence anomalies through a similar hydrostatic surface pressure adjustment mechanism to that proposed by Lindzen and Nigam (1987). Then, the moisture convergence anomalies associated with the anomalous mass convergence field are determined by assuming a characteristic boundary layer specific humidity content. **Figure 7** shows that SST-driven

anomalies may be just as important as horizontal moisture advection for driving a positive moisture tendency in advance of enhanced MJO precipitation in the Indian Ocean MJO initiation region for plausible boundary layer model parameter settings. Horizontal advection was previously hypothesized to be the leading terms in the intraseasonal moisture budget in the context of MJO propagation. These results suggest that SST-induced boundary layer moisture convergence may play an important role in MJO propagation and initiation, and may help explain why coupled models produce better simulations of the MJO than uncoupled atmospheric models, and highlights the salient upper ocean and boundary layer processes that models need to get right to produce realistic MJO variability. A manuscript describing these results is being prepared for *J. Climate*.

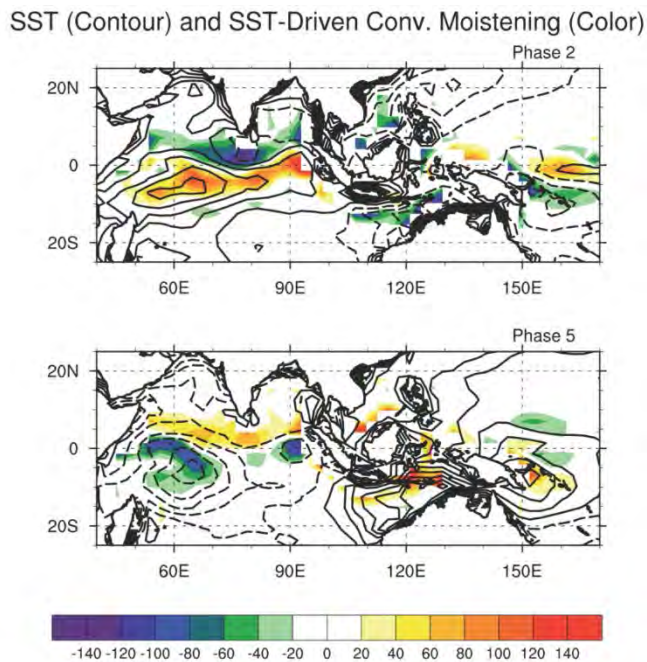

Figure 6. SST anomalies (contours) and SST-driven moisture convergence anomalies (colors) for Phases 2 and 5 of the MJO in the SPCCSM. The SST contour interval is $0.05^{\circ}C$, and the units of convergence anomalies are $W m^{-2}$. Note that the convergence anomalies have been converted to energy units to reflect latent heat convergence.

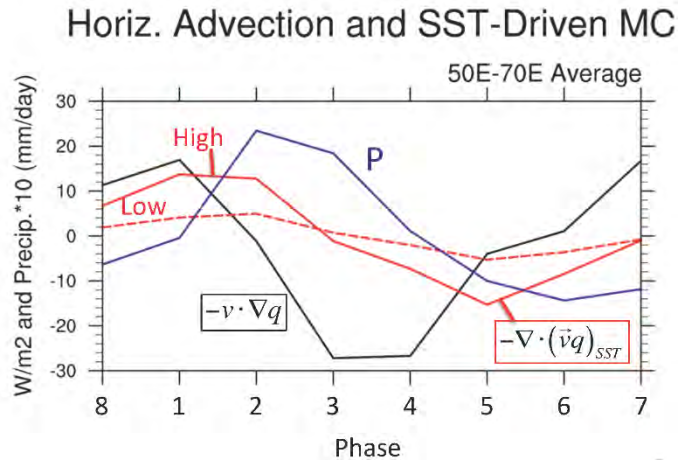
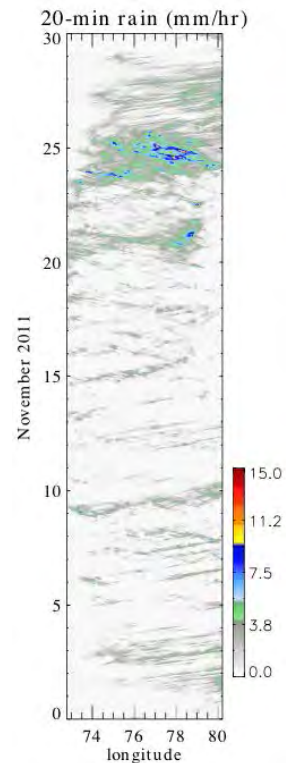

Figure 7. Composite 10°N-10°S averaged Indian Ocean precipitation, column-integrated horizontal moisture advection, and SST-driven moisture convergence anomalies in the SPCCSM as a function of MJO phase. High and low estimates for the SST-driven convergence anomalies are provided based on plausible parameter settings of the Back and Bretherton (2009) boundary layer model.

Understanding DYNAMO MJO Initiation in a high resolution regional model (Riley Dellaripa et al. 2017).

Figure 8. Model 20 minute rain rate in the DYNAMO Northern Sounding array as a function of time for the November 2011 DYNAMO event. Units of rainrate are mm day⁻¹.



A cloud system resolving version of the RAMS model (the predecessor regional version of OLAM) forced with DYNAMO datasets demonstrates realistic representation of MJO convective variability during the DYNAMO field program when integrated over the Northern

Sounding Array (**Figure 8**). Horizontal model grid spacing in 1.5 km. The model demonstrates a realistic simulation of air-sea coupling via wind-induced surface flux variability, assessed versus buoy sites in the Indian Ocean initiation region, and also produces a comparable representation of convective organization to that of DYNAMO observations. Latent heat flux variability is very strongly correlated with precipitation variability, both locally and in the domain average. The realistic convective partitioning from the model is represented in a plot of stratiform-convective fraction as a function of time (**Figure 9**).

Detailed analysis of this run provides a mixed picture as to the support of convective organization in the model by surface fluxes. During the MJO suppressed phase, individual convective systems are supported by wind-driven flux feedbacks both before and during the mature phase of mesoscale convective systems. However, during the MJO onset and mature phases, while surface fluxes support individual mesoscale convective systems during their growth stage, mature MCSs are provided no support by wind-induced flux anomalies, similar to recent work in RCE frameworks used to examine self-aggregation. Model sensitivity tests that constrain fluxes to be homogeneous spatially or time invariant does not suggest that a robust wind-induced flux feedback is produced in this model, although a different form of simulations based on WTG theory may be needed to verify this. The WTG moistening diagnostics of Wolding and Maloney (2015b) are also applied in this run indicating substantial support for MJO convective variability by radiative feedbacks and their impact on the mid- and lower-tropospheric moisture budget. A paper describing these results is provisionally accepted in *J. Atmos. Sci.*

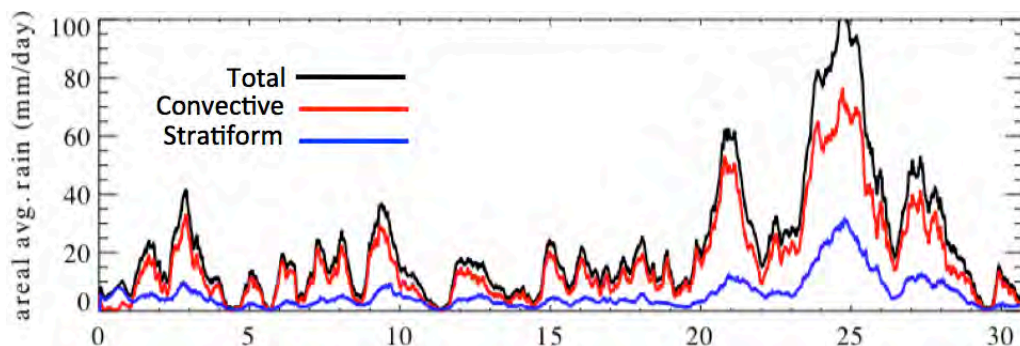

Figure 9. Northern Sounding Array stratiform-convective partitioning as simulated by the RAMS model. The x-axis represents day of the month November 2011.

Highlights of Accomplishments

- Analysis of OLAM indicates the importance of simulating a realistic Indian Ocean moisture budget for producing a realistic MJO simulation, particularly an appropriate effect of deep convection and its associated large-scale circulations on the moisture budget
- Objective weak temperature gradient MJO diagnostics of the DYNAMO region and broader domain applied to observations and global and regional models indicate that the MJO is destabilized by radiative feedbacks, and propagated eastward by horizontal

moisture advection.

- Aquaplanet model experiments indicate that Rossby gyres associated with the previous cycle of MJO convection help to initiate the MJO, and that Kelvin wave circumnavigation plays a secondary role.
- We showed that MJO hindcasts during the DYNAMO period could be improved through increasing convective entrainment.
- We showed that with increased entrainment, the NCAR CAM5 appears to produce a good MJO for the wrong reasons, with a bottom-heavy heating profile compensating for too weak of cloud-radiative feedbacks. This highlights areas of improvement for climate models.
- The SP-CAM produces an improved representation of the MJO relative to the NCAR CAM during the DYNAMO period, although the SP-CAM exhibits a poorer MJO skill score based on RMSE since SP-CAM mean state drift projects strongly onto the MJO indices used to assess skill.
- Advanced MJO diagnostics were developed that showed the RMM index to be dominated by east Pacific 200 hPa zonal wind variability during the October DYNAMO event that erroneously suggested a weakening of the event at the end of October.
- We showed that ocean coupling may help produce MJO initiation through SST-driven convergence that aids column moistening in advance of MJO convection, highlighting why uncoupled models have difficulty simulating the MJO

Publications From the Project

- Hannah, W. M., and E. D. Maloney, 2014: The Moist Static Energy Budget in NCAR CAM5 Hindcasts during DYNAMO. *J. Adv. Modeling Earth Sys.*, **6**, doi:10.1002/2013MS000272.
- Hannah, W. M., E. D. Maloney, and M. Pritchard, 2015: Consequences of Systematic Model Drift in DYNAMO MJO Hindcasts with SP-CAM and CAM5. *J. Adv. Modeling. Earth Sys.*, **7**, 1051–1074.
- Wolding, B. O., and E. D. Maloney, 2015: Objective Diagnostics and the Madden-Julian Oscillation. Part I: Methodology. *J. Climate*, **28**, 4127–4140.
- Wolding, B. O., and E. D. Maloney, 2015: Objective Diagnostics and the Madden-Julian Oscillation. Part II: Application to Moist Static Energy and Moisture Budgets. *J. Climate*, **28**, 7786–7808.
- Maloney, E. D., and B. O. Wolding, 2015: Initiation of an Intraseasonal Oscillation in an Aquaplanet General Circulation Model. *J. Adv. Model. Earth. Sys.*, **7**, 1956–1976.
- Wolding, B. O., E. D. Maloney, and M. Branson, 2016: Vertically Resolved Weak Temperature Gradient Analysis of the Madden-Julian Oscillation in SP-CESM. *J. Adv. Modeling. Earth. Sys.*, **8**, doi:[10.1002/2016MS000724](https://doi.org/10.1002/2016MS000724).
- Wolding, B. O., E. D. Maloney, S. A. Henderson, and M. Branson, 2017: Climate Change and the Madden-Julian Oscillation: A Vertically Resolved Weak Temperature Gradient Analysis. *J. Adv. Modeling Earth Sys.*, **9**, doi:10.1002/2016MS000843.
- Maloney, E. D., B. O. Wolding, R. Walko, W. Cotton, and G. Carrio, 2017: MJO Initiation during DYNAMO events in the Ocean Atmosphere Land Model. *J. Adv. Model. Earth. Sys.*, to be submitted.
- DeMott, C., S. deSzoek, B. O. Wolding, and E. D. Maloney, 2017: SST-driven boundary layer convergence moistening and the MJO in the SP-CESM. *J. Climate*, to be submitted.

Riley Dellaripa, E. E. Maloney, and S. van den Heever, 2017: Wind-flux feedbacks and convective organization during the November 2011 MJO event in a high resolution model. *J. Atmos. Sci.*, accepted pending revision.

PI Contact Information

Eric D. Maloney (lead PI)
Department of Atmospheric Science
Cooperative Institute for Research in the Atmosphere (CIRA)
Colorado State University
1371 Campus Delivery
Fort Collins, CO 80523-1371
Phone: (970) 491-3368
Fax: (970) 491-8449
emaloney@atmos.colostate.edu

William Cotton (co-PI)
Department of Atmospheric Science
Cooperative Institute for Research in the Atmosphere (CIRA)
Colorado State University
1371 Campus Delivery
Fort Collins, CO 80523-1371
Phone: (970) 491-8593
Fax: (970) 491-8449

Robert Walko (co-PI)
Rosenstiel School of Marine and Atmospheric Science,
University of Miami,
4600 Rickenbacker Causeway,
Miami, FL 33149-1031.
Phone: (305) 421-4621

Future Work:

We are operating under a no-cost extension request for this project that will extend work into Year 4. In particular, we will concentrate on completing the following tasks in the no-cost extension period:

- 1) Complete a manuscript on our nudged OLAM simulations that documents the importance of properly simulating the impact of convection on the tropospheric moisture budget for producing a realistic MJO during November 2011. Vertical structure will be a key focus of this investigation.
- 2) Bob Walko of UM will lead work that examines whether higher horizontal resolution, an improved PBL scheme, and creating more physical separation of parameterized convection from the inner OLAM domain would produce an even better MJO simulation

- 3) We will assess the sensitivity of the OLAM MJO to radiative feedbacks by strengthening the radiative impact of microphysical species to allow a stronger impact of radiation anomalies on moistening.
- 4) How the variation of cloud populations as a function of phase contributes to the tropospheric moisture budget during an MJO lifecycle in OLAM will be documented using the WTG diagnostic method of Wolding and Maloney (2015).